

# THE STA-LEVEL—AUTOMATIC PROGRAM LEVEL AMPLIFIER



## THE STA-LEVEL

Perhaps no single equipment in all of broadcasting has done so much for so little cost as the Gates *Sta-Level*. The basic function is to provide constant level output. *Sta-Level* might be likened to a gentle electronic hand on the master gain control. When the volume is too low, *Sta-Level* will raise it. If volume is too high, *Sta-Level* will automatically reduce it. This automatic adjustment for different input levels allows average output levels to be higher (for there is automatic protection)—while the low soft passages are automatically raised in level—resulting in a uniformly higher level of transmission and the equivalent of greater signal output.

**RECOVERY SPEED:** As supplied, *Sta-Level* recovers  $\frac{2}{3}$  level in 7 seconds and 90% level in about 28 seconds. This is considered typical. However, a kit of small fixed resistors

is supplied. If the operator feels this is too slow or too fast, he may, by changing two resistors, increase recovery to as fast as  $\frac{2}{4}$  seconds for  $\frac{2}{3}$  level, and 10 seconds for 90% level; or as slow as  $1\frac{1}{4}$  seconds for  $\frac{2}{3}$  level, and 45 seconds for 90% level.

**ACCESSORIES:** None are needed for the *Sta-Level* is a self-contained one-chassis unit complete with regulated power supply.

**GAIN:** As *Sta-Level* has up to 62 db. gain, if your present system is short of gain, *Sta-Level* will pick it up. Both input and output level controls are on the front panel to adjust for any gain you wish right down to unity or up to the full 62 db.



Right: Front panel drops down for easy servicing of all inner parts.

Left: rear view shows terminations and tube locations.

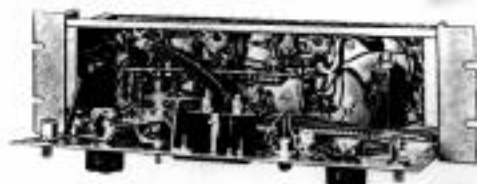

## SPECIFICATIONS

**MODE:** Single channel monaural.  
**CONTROLS:** Input and output level controls.  
**METER:** Reads decibels of compression.  
**IMPEDANCES:** 500/600 ohms input and output.  
**GAIN:** 62 db. adjustable at both input and output.  
**RESPONSE:**  $\pm 1$  db. 30-15,000 cycles.  
**DISTORTION:** 1% or less 50-15,000 cycles at 30 db. compression or less and at + 20 dbm. output threshold level.  
**NOISE:** 65 db. below 0-30 db. compression at + 20 dbm. threshold level.  
**MAXIMUM VOLUME EXPANSION:** Variable as set by input control.  
**EXPANSION RISE TIME:** Factory set at 7 seconds. Kit provided for faster or slower action as desired.  
**EXPANSION RECOVERY TIME:** Approximately 25 milliseconds.

**MAXIMUM COMPRESSION:** 30 db. at 1% distortion. 40 db. at slightly greater distortion.  
**COMPRESSION ATTACK TIME:** Approximately 25 milliseconds.  
**COMPRESSION RECOVERY TIME:** Normal 7 seconds for 63% recovery. Faster as compression becomes greater.  
**SERVICING:** Drop down front panel. Tubes on rear.  
**POWER:** 117 volts, 50/60 cycles, 45 watts.  
**MECHANICAL:** Size, 19" x 5 $\frac{1}{4}$ " x 7" deep. Weight packed: 40 lbs. domestic; 50 lbs. export. Cubage: 2 cu. ft. Finish: Medium gloss gray and black.  
**TUBES:** (2) 6V6, and (1 each) 6386, 12AT7, 6AL5, OB2, 5Y3GT.

## ORDERING INFORMATION

Sta-Level with tubes ..... (Cat. No.) M-5167  
Spare 100% tube kit ..... TK-243

# INSTRUCTION BOOK

Sta-Level - M5167 Gates Automatic Gain Amplifier

No. IB-888 0062 001

This unusual amplifier is often referred to as the "operator's third hand". As it does its work smoothly and is not intended to be an instantaneous device, a peak limiting amplifier, such as the Gates SA-39B Limiter, should always follow the Sta-Level at some point in the system.

Usually Sta-Level is located at the studios and is often mounted between the audio console output and the input to the line feeding the transmitter. Where transmitter and studios are together, Sta-Level would be usually placed between the audio console output and the Limiter input.

**STA-LEVEL PURPOSES:** Are to (1) automatically adjust upward or downward, the over-all program level fed to the transmitter, to prevent either excessive average level or insufficient average audio level. It will make these adjustments with no more distortion than a straight high quality program amplifier. — (2) for automatic feeding such as by setting microphone gain above turntable levels. In this way, when voice announcements are made, the turntable sound will be lower and turntable gain will restore when voice is discontinued.

## IMPORTANT

— In case of damage in transportation, notify the delivering carrier at once. After he has approved the damage report, which indicates he will accept your billing for the damage — order new part/s from Gates. Our billing for these parts, plus transportation expense, will be your claim to the transportation company.

## INSTALLATION

Sta-Level should be installed where the meter may be observed. If the necessary location is away from regular visibility, meter may be ordered for extension to the control console (Part 911-1308-001). When making connections, use shielded wire and do not lace input and output wires in the same cable. Also AC wiring should be separate. Connections are:

	Terminal Strip	Connect To
Input 500/600 ohms	TB-1	1 & 3
Output 500/600 ohms	TB-2	4 & 5
Ground	TB-1	2
Ground	TB-2	6
115 volts 60 cycles	TB-2	7 & 8

It is suggested that this unit not be mounted in the rack directly adjacent to a high field instrument such as a multi-motor tape recorder. A few inches of buffer is desirable.

## OPERATION

These general specifications will assist in determining good operation:

**Gain:** 35 db.  $\pm$  2 db.

**Distortion:** 1% 30-15,000 cycles to 30 db. compression.

**Response:** 30-15,000 cycles  $\pm$  1 db.

**Tubes:** (2) 6V6, (1 each) 6386, 12AT7, 6AL5, 5Y3GT, OB2.

**Compression Ratio:** Approximately 3.3 to 1 compression and threshold is  $\pm$  10 to  $\pm$  12 dbm.

**Power:** 115 volts 50/60 cycles.

These steps will assure quick operation and easy understanding:

- (1) Allow to warm up a few minutes by turning on toggle switch. Pilot light will indicate when on.
- (2) Remember, gain is not the purpose of Sta-Level. Other amplifiers in your system do this function. Input and output controls are thus provided for adjustments for proper operation and not for gain.
- (3) The VU meter on your audio console is important in the adjustment. Feed a program, such as a record, through the audio console to the Sta-Level. In so doing, peak the console VU meter to 100 or that point you ride top gain.
- (4) Now adjust the input control on Sta-Level until the compression meter reads about 15 db. concurrent with the 100 reading on the console VU meter.
- (5) If Sta-Level is to feed a telephone line, adjust the output control on Sta-Level to  $\pm$  8 VU. This may be measured on a VU meter, if one is available. Most operators can determine  $\pm$  8 VU by listening.

- (6) If the studios and transmitter are combined and Sta-Level will feed the input to a Limiting Amplifier, adjust the output of Sta-Level to center range (12 o'clock) and use input control on Limiter for proper input level to Limiter.

NOTE: Operating levels of the system do not require constant surveillance as this is the purpose of Sta-Level. After familiarity, some touch up adjustments for more or less compression may be desirable to fit the exact needs of your operating desires.

#### RECOVERY TIME

Remember, the object of Sta-Level is to act with only modest speed or about the same as if you were turning a gain control by hand. — You may wish to experiment with recovery time to see which fits your program techniques best. — On the front panel is a switch marked "Double" and "Single" to change recovery time.

(Single) — Moderate attack time and moderate recovery time. This could be called a gentle control of either expansion or compression.

(Double) — Faster attack time and more rapid recovery time. For the fast moving program technique, this position would probably be preferred.

A few days of use will determine what recovery position is best for your mode of operation.

#### OTHER HELPFUL INFORMATION

Input Pad: A 20 db. H pad is installed between the input (terminals 1 and 3 on TB-1) and the input transformer. If more gain is needed in the over-all system, this pad may be removed. However, input level to the Sta-Level should not exceed  $\pm 4$  dbm. if this pad is removed.

Output Pad: It is suggested that this pad not be altered or removed due to its sensitive nature in the circuit.

Voltage Regulator Tube: This is V5 or the OB2 tube. As it is adjusted to draw only 5 MA., the tube may appear inoperative by lack of glow. By looking at the base of the tube in the dark, it will indicate a slight glow and this is proper.

Voltage Readings: These are shown on the schematic diagram C-19530. A vacuum tube voltmeter is preferred in checking voltages. A 20,000 ohm per volt meter is also satisfactory. Remember, voltages will vary slightly with various makes of test meters, thus approximate near readings would probably indicate correctness. Likewise, all tubes are not the same. One drawing a little less current would increase the voltage in a resistance circuit or one drawing more current would reduce the voltage. In push-pull stages, balanced voltages indicate balanced currents and this is very important to Sta-Level performance.

Maintenance: Keep clean, inside and out. Every three months, move tubes in and out of sockets several times to clean tube socket contacts. In case of non-operation, replace all tubes with an entire new set and then work backwards to find the faulty tube.

#### PARTS LIST

Symbol No.	Gates Part No.	Description	Symbol No.	Gates Part No.	Description
A1	396 0063 000	Neon Lamp	R19, R20, R21, R22	540 0204 000	Res., 150K ohm, 1/2W.
C1, C2, C5, C6, C8, C9	506 0014 000	Cap., .1 mfd., 400(W)V.	R15, R16	540 0180 000	Res., 1500 ohm, 1/2W.
C3, C4	506 0011 000	Cap., .02 mfd., 400(W)V.	R17, R18	540 0201 000	Res., 82K ohm, 1/2W.
C7	524 0079 000	Cap., 15-15-10 mfd., 450V.	R23	542 0061 000	Res., 150 ohm, 10W.
C10, C13	506 0007 000	Cap., .5 mfd., 200(W)V.	R24	540 0753 000	Res., 12K ohm, 2W.
C11	506 0008 000	Cap., 1.0 mfd., 200(W)V.	R25, R26	540 0035 000	Res., 270 ohm, 1/2W.
C12	524 0062 000	Cap., 20-20 mfd., 450V.	R29, R30	540 0030 000	Res., 160 ohm, 1/2W.
F1	398 0019 000	Fuse, 2 amp.	R27	552 0546 000	Control, 1000 ohm
L1	476 0007 000	Filter Choke	R28	540 0032 000	Res., 200 ohm, 1/2W.
M1	911 1308 001	Compression Meter	R31	540 0762 000	Res., 68K ohm, 2W.
R1	550 0192 000	Dual Control, 100K ohm	R32	540 0365 000	Res., 24K ohm, 1W.
R2, R3, R4, R5	540 0034 000	Res., 240 ohm, 1/2W.	R33, R34	540 0207 000	Res., 270K ohm, 1/2W.
R6	540 0027 000	Res., 120 ohm, 1/2W.	R35	540 0199 000	Res., 56K ohm, 1/2W.
R7	540 0164 000	Res., 68 ohm, 1/2W.	R36	540 0222 000	Res., 4.7 megohm, 1/2W.
R8, R9	540 0028 000	Res., 130 ohm, 1/2W.	R37	540 0226 000	Res., 10 megohm, 1/2W.
R10, R11	540 0480 000	Res., 10K ohm, 1W.	R38	550 0159 000	Control, 10K ohm
R12	540 0642 000	Res., 20K ohm, 2W.	R39	540 0377 000	Res., 75K ohm, 1W.
R13, R14	540 0208 000	Res., 330K ohm, 1/2W.	R40	540 0051 000	Res., 1200 ohm, 1/2W.
			R41	552 0541 000	Control, 100 ohm
			R42	540 0759 000	Res., 39K ohm, 2W.
			R43	540 0104 000	Res., 200K ohm, 1/2W.
			Sl, S2	604 0005 000	Switch

Symbol No.	Gates Part No.	Description
T1	478 0144 000	Input Transf., AI-10386T
T2	478 0421 000	Output Transf., AO-11302T
T3	472 0255 000	Power Transf., AP-11303T
TB1	614 0070 000	Terminal Board
TB2	614 0072 000	Terminal Board
V1	370 0213 000	Tube, 6L6386
V2	370 0112 000	Tube, 12AT7
V3, V4	370 0102 000	Tube, 6V6GT
V5	370 0002 000	Tube, OB2

Symbol No.	Gates Part No.	Description
V6	370 0030 000	Tube, 6AL5
V7	370 0020 000	Tube, 5Y3GT
XA1	406 0129 000	Pilot light assembly (red)
XF1	402 0021 000	Fuseholder
XV1, XV2	404 0041 000	Socket
XV3, XV4, XV7	404 0016 000	Socket
XV5, XV6	404 0036 000	Socket

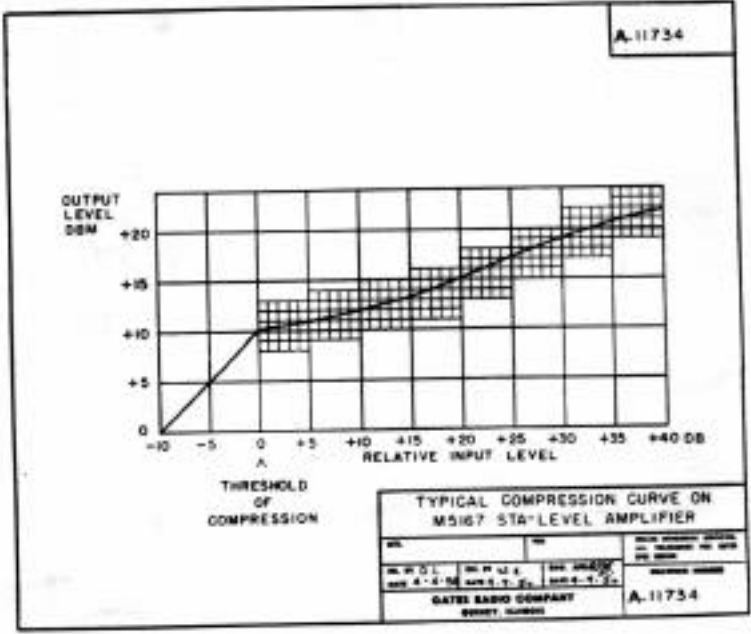
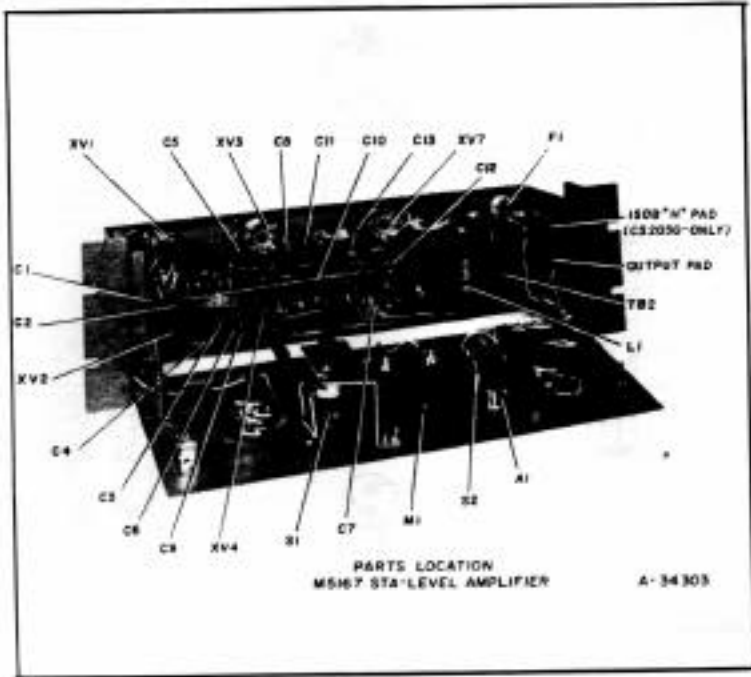
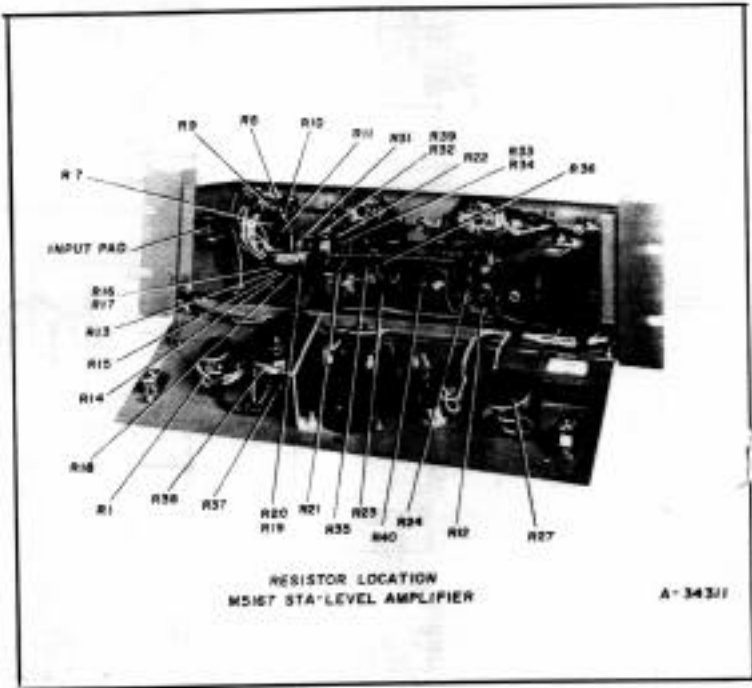
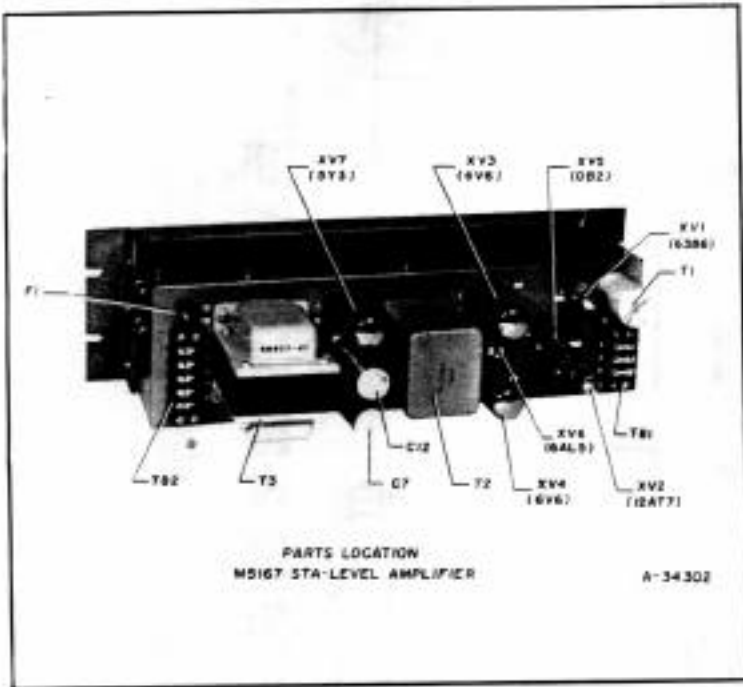



Model  
Type  
Quantity

C-19530

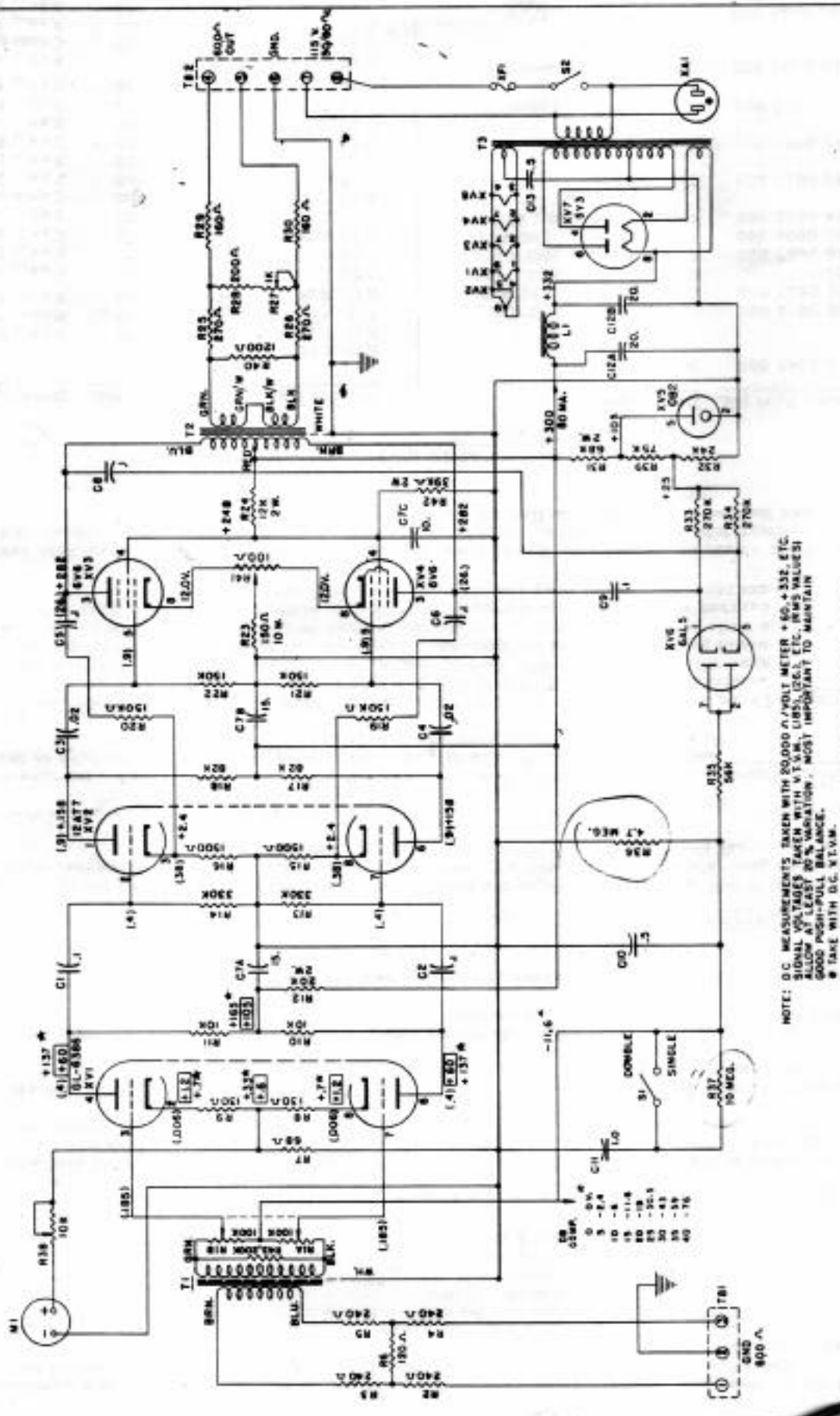

NOTE: D.C. MEASUREMENTS TAKEN WITH 20,000 Ω/VOLT METER +60, +332, ETC. SIGNAL VOLTAGES TAKEN WITH V.T.V.M. (185), (26), ETC. (R.M.S. VALUES) ALLOW AT LEAST 20% VARIATION. MOST IMPORTANT TO MAINTAIN GOOD PUSH-PULL BALANCE. \* TAKE WITH D.C. V.T.V.M.

NOTE: ALL MEASUREMENTS TAKEN WITH 150Ω COMPRESSION, EXCEPT (26) WHICH IS TAKEN WITH NO COMPRESSION. AT THESE POINTS THE "150Ω COMP" READINGS ARE MARKED WITH OTHER DC. READINGS DO NOT CHANGE.

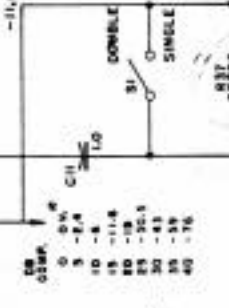

FORM NO. 1-7-31	REV. 1-1-32	SCHAFFNER	
CWA 435		RAY M-40	REV. 4-1-35
REV. 4-1-35	REV. 4-1-35	REV. 4-1-35	REV. 4-1-35
GATES RADIO COMPANY		SCHAFFNER	
SANTA ANA, CALIF.		SANTA ANA, CALIF.	

SCHEMATIC DIAGRAM  
STA-LEVEL AMPLIFIER M587

C-19530