

**dbx<sup>®</sup> Model 2BX**  
two band dynamic range enhancer  
**INSTRUCTION MANUAL**



**WARNING: TO PREVENT FIRE OR SHOCK  
HAZARD, DO NOT EXPOSE THIS APPLIANCE  
TO RAIN OR MOISTURE.**

dbx<sup>®</sup> is a Registered Trademark of dbx, Inc.

## INDEX

|  |    |
|--|----|
| BRIEF OPERATING INSTRUCTIONS                       | 2  |
| INTRODUCTION                                       | 4  |
| CONNECTIONS  | 4  |
| OPERATION  | 7  |
| EXPANSION  | 7  |
| SIMPLE PRECAUTIONS WHEN USING ANY PROGRAM EXPANDER | 8  |
| HOW dbx EXPANDERS WORK                             | 10 |
| SPECIFICATIONS                                     | 15 |
| dbx PRODUCT WARRANTY                               | 16 |
| FACTORY SERVICE                                    | 16 |
| SCHEMATIC  | 17 |
| GLOSSARY   | I  |

## BRIEF OPERATING INSTRUCTIONS

2

**PILOT** This L.E.D. (light emitting diode), above the POWER switch, glows when the 2BX is ON.

**GAIN CHANGE L.E.D.'s** These two rows of L.E.D.'s indicate the amount of gain change created in each of the 2BX's two frequency bands. The red L.E.D.'s indicate upward expansion (volume increase), the yellow L.E.D.'s indicate downward expansion (volume decrease).

**TRANSITION LEVEL** When an incoming signal is above the level set by this control, the 2BX expands upwards; when an incoming signal is below the level set by this control, the 2BX expands downward. Set the control so that red GAIN CHANGE L.E.D.'s glow during loud portions of the program and yellow GAIN CHANGE L.E.D.'s glow during the quiet portions of the program.

**SOURCE** Push this switch and the PRE switch to expand programs coming from your phonograph, FM tuner or other auxiliary equipment.

**TAPE** Push this switch and the POST switch to expand programs coming from your tape recorder. If you do not have a tape recorder, push the SOURCE switch.

**PRE** Push this switch to expand a program before recording it.\*

**POST** Push this switch and the TAPE switch to expand a program played back from your tape recorder.

**POWER** Push this switch once (IN) to turn the 2BX ON; push again (OUT) for OFF.

**EXPANSION** Adjust this slide control for the desired amount of expansion. A "1.4" setting means that an input signal with a 40dB dynamic range will be expanded to 56dB, or that an input signal with a 50dB dynamic range will be expanded to 70dB. A 1.2 setting would result in a 20% increase in dynamics; a 1.4 setting would result in a 40% increase in dynamics, etc.

**(PRE/POST Summary)** The PRE switch expands the signal before the tape recorder input (PRE places the expander *before* the tape recorder input); the POST switch expands the signal from the tape recorder's output (POST places the expander *after* the tape recorder output). Pushing both PRE and POST switches simultaneously bypasses the expander functions.

*\*Expansion will, in most cases, increase the dynamic range of a program beyond the capabilities of your tape recorder. To capture this increased dynamic range on tape requires a dbx noise reduction system, which allows recording at levels below the tape or tape head's saturation point. To expand a program and then record it, we recommend using any dbx tape noise reduction system and carefully setting record and expansion levels. If you do not have a dbx tape noise reduction system, we recommend expanding a program upon playback (place the 1bx in TAPE and POST mode).*



**RECORDER OUTPUTS\*** Connect the cables from these outputs to the Line inputs of your tape recorder. If you do not have a tape recorder, do not connect any cables to these outputs.

**RECORDER INPUTS\*** Connect the cables from your tape recorder Line or Monitor outputs to these inputs. If you do not have a tape recorder, do not connect any cables to these inputs.

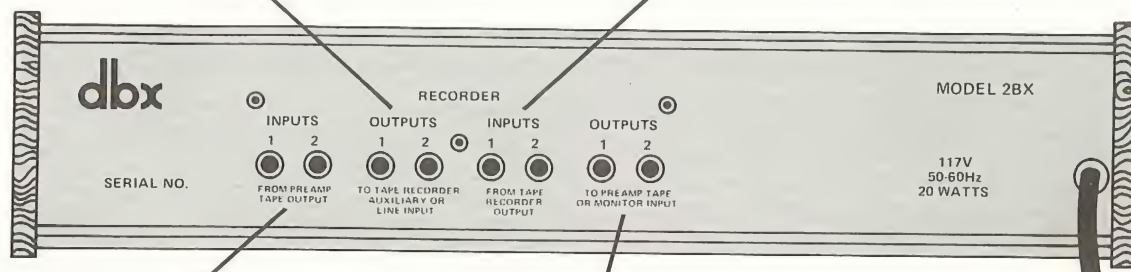

**INPUTS** Connect the cables from the Tape Outputs of your receiver, preamplifier, or integrated amplifier to these inputs.

**OUTPUTS** Connect the cables from these outputs to the Tape Inputs, or Monitor Inputs of your receiver, preamplifier, or integrated amplifier.

**AC POWER CABLE** In the U.S.A. connect this cable to a 117V AC, 50 or 60Hz AC power source. The 2BX requires a maximum of 20 watts of AC power. Models for use with power sources outside the United States are available. Contact the dbx factory for information.

*\*If you have a dbx tape noise reduction system (such as any of our 120 or 150 series) see Page 9 for connection diagrams.*

## INTRODUCTION

If you're a music lover or an audiophile (or both), you have probably noticed that much of the excitement of a live performance is missing in a recorded or broadcast performance. The primary reason for this loss of excitement is that the dynamic range of the recorded or broadcast performance has been purposely restricted to fit the dynamic range limitations of the recording or broadcast medium.

The 2BX is a sophisticated expander that can restore the dynamic range and excitement to a recording or radio broadcast, adding considerably to your listening enjoyment. By expanding dynamic range, the 2BX lowers the characteristic noise levels of a tape, phonograph record, or FM broadcast. It restores the "punch" of loud passages, and the whisper of quiet ones. It can add new life to an old record collection, and make FM broadcasts worth listening to. The use of a 2BX with a dbx tape noise reduction system (such as our 120 or 150 series), lets you make tape copies of records, FM broadcasts or other tapes that actually sound better than the original. With these capabilities, the 2BX will become one of the most valued components in your home music system.

## CONNECTIONS

### AC POWER

Connect the 2BX to a 117V AC, 50 or 60Hz power source only. The 2BX requires 20 watts of AC power (maximum). As a precaution, do not connect the AC power cable until all signal connections have been made.

(Models for use with foreign power sources are available. Contact the dbx factory for information.)

### SIGNAL CONNECTIONS

#### NOTES:

1. If you do not have a tape recorder, do not connect anything to the TO TAPE RECORDER, or the FROM TAPE RECORDER jacks.
2. With the setup in Figure 2, changes in preamp volume will require adjustment of the 2BX transition level.
3. If you do have a tape recorder and wish to expand before you record, use the connections shown in Figures 1, 2 or 3.
4. If you have a dbx tape noise reduction system, see Page 9.

Connect the 2BX to your system according to one of the following diagrams:

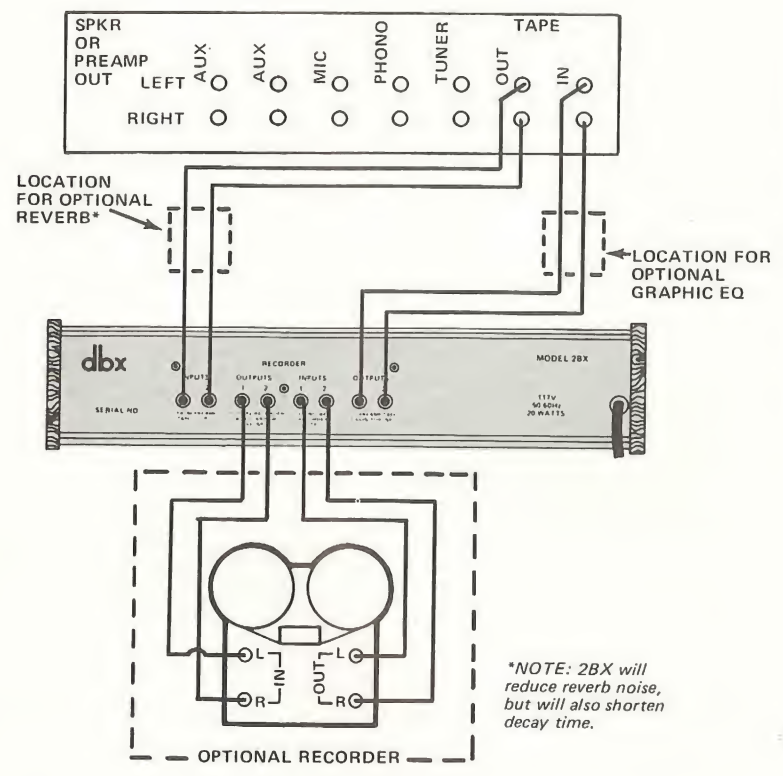

Fig. 1 - How to Connect the 2BX to Your Receiver, Preamp or Integrated Amplifier. This is the preferred hookup assuming a tape monitor loop is available.

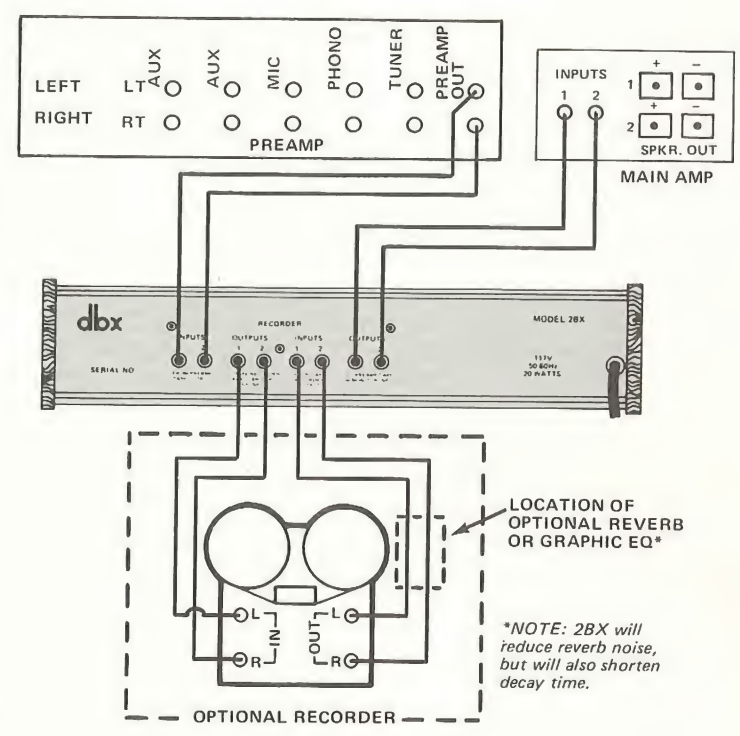

Fig. 2 - How to Connect the 2BX if a tape monitor loop is unavailable and you are using a separate preamp and power amp (or between preamp out and main amp in jacks).

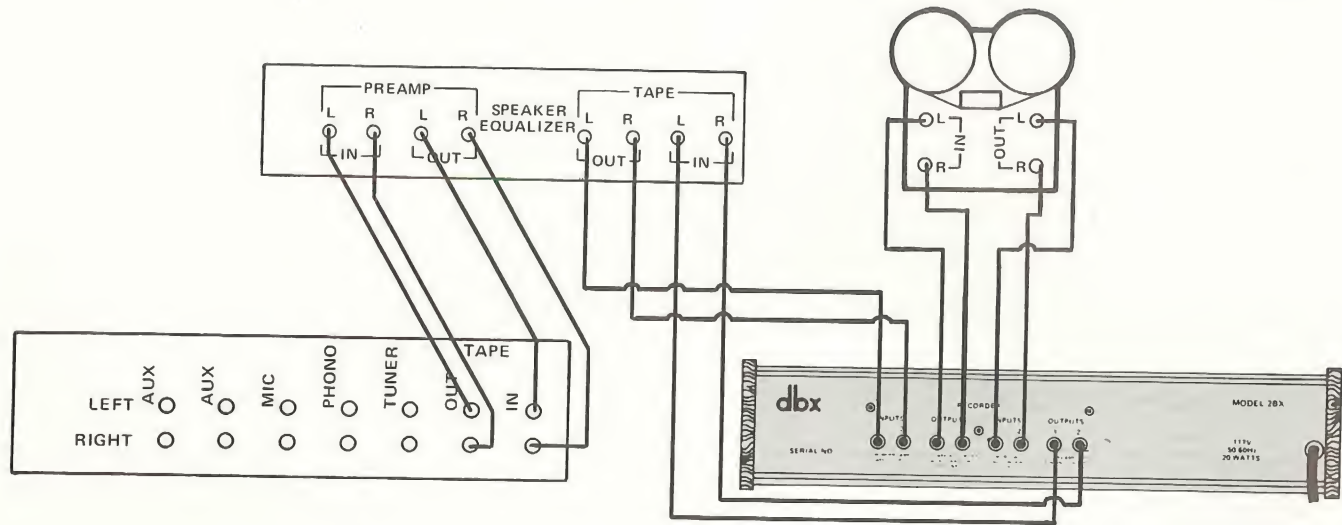

Fig. 3 - How to Connect the 2BX in the Tape Monitor Loop of a Graphic Equalizer or Speaker Equalizer.



## OPERATION

### NOTES:

1. For a description of control functions, see the BRIEF OPERATING INSTRUCTIONS at the front of this manual.
2. If you do not have a tape recorder connected as shown in Figures 1 through 3, press IN the SOURCE and PRE buttons.
3. To avoid repetition, we will use the word "amplifier" to refer to your receiver, preamplifier or integrated amplifier.

### EXPANSION

#### To Expand an FM Broadcast or a Conventional Phonograph Disc

1. With your amplifier's master volume control all the way down, turn on the AC Power for your entire system.
2. Select the desired source (FM or disc) on your amplifier's selector switch.
3. Place 2BX in SOURCE and PRE mode (SOURCE and PRE buttons IN).
4. Set the EXPANSION RATIO and the TRANSITION LEVEL (threshold) controls to approximately mid position.
5. With the music playing, readjust the TRANSITION LEVEL control until red L.E.D. GAIN CHANGE indicators glow on loud passages, and the yellow L.E.D. GAIN CHANGE indicators glow on quiet passages\*.

*\*The L.E.D. GAIN CHANGE indicators show the relative amount of expansion produced by the 2BX in each of its two frequency bands. When one or more red L.E.D.'s light in a given band, the 2BX is raising the program level in that band. When one or more of the yellow L.E.D.'s light, the 2BX is lowering the program level in that band. The number of L.E.D.'s that light correspond to the relative amount of expansion up to the maximum displayable range. More upward or downward expansion can be achieved than is shown on the display.*

6. Slowly bring up your amplifier's master volume control to the desired listening level.

7. Readjust the EXPANSION control for the desired amount of expansion. This will depend on the program being expanded. For a good classical phonograph disc, an expansion ratio of 1:1.1 or 1:1.2 (settings of 1.1 or 1.2) may be optimum. For a highly compressed FM broadcast, an expansion ratio of 1:1.4 or 1:1.5 (settings of 1.4 or 1.5) may produce better results. If you're not sure where to set the EXPANSION control, start at a low setting, and move it higher until it sounds extreme, then move the control back so the sound is natural again.

The degree of expansion desired also depends on the mood of the listeners. Generally, you will desire larger amounts of expansion when you are totally involved with the music.

#### To Expand a Tape During Playback

Follow the instructions above for expanding an FM broadcast or conventional phonograph disc, except place the 2BX in TAPE and POST mode (TAPE and POST buttons IN). It is not necessary to expand a dbx-encoded tape after decoding (during playback) if the tape has already been 2BX-expanded prior to recording.

If you have two tape recorders only one TAPE input, and you use one recorder primarily for playback, plug it into your amplifier's AUX INPUTs; then follow the directions for Expanding an FM Broadcast or a Conventional Phonograph Disc (as already described).

#### How to Expand and Tape Record a Program

**NOTE:** Expanding a program and then recording it may cause the dynamic range of the program to exceed the dynamic range of your tape recorder. This could add distortion and/or excessive tape noise to the recording.

(An exception would be for very highly compressed programs, where expansion prior to recording adds only a modest margin to the dynamic range.) To avoid these problems, dbx recommends the use of a dbx tape noise reduction system when expanding before recording (see next page for how to connect your system).

1. With your amplifier's master volume control and your recorder's input level controls all the way down, set your recorder to the "record ready" (RECORD and PAUSE).
2. Select the desired source on your amplifier's selector switch.
3. Place the 2BX in SOURCE and PRE mode (SOURCE and PRE buttons IN).
4. Play the source (start the phonograph disc or listen to the FM station you will be recording). Set the TRANSITION LEVEL control so that the red L.E.D. GAIN CHANGE indicators glow on loud passages, and the yellow L.E.D. GAIN CHANGE indicators glow on quiet passages. Set the EXPANSION control for the desired amount of expansion. If you're not sure where to set the EXPANSION CONTROL, start at a low setting, and move it higher until it sounds extreme, then move the control back until the sound is natural again.
5. Bring up the amplifier's master volume control to the desired listening level.
6. Now adjust the input level controls on your tape recorder for normal VU meter readings. You may find that slightly lower record levels are necessary when recording an expanded program in order to avoid tape saturation.
7. Restart the program and record it normally.

If your tape recorder has tape monitoring provisions (a three-head machine), and you wish to monitor the recording as it is being made, place the 2BX in TAPE mode (TAPE button IN). This monitors the signal coming

from the tape recorder's outputs without changing the expander's input to the tape recorder.

#### SIMPLE PRECAUTIONS WHEN USING ANY PROGRAM EXPANDER

The 2BX (or any expander) places greater demands on your power amplifier and speakers. Whether or not a given amplifier is of adequate power rating is not always easy to determine; it depends partially on the sensitivity of the speakers, and partially on the distortion characteristics of the amplifier.

Set for 1:1.5 expansion, the 2BX will expand a good 60dB classical recording to about 90dB of dynamic range. Full realization of the benefit of this dynamic range requires both a hefty power amplifier and speakers that can take the high power. If you have such equipment, the results will be breathtaking. Fortunately, such components are not mandatory for full enjoyment of the 2BX.

The most important point is this: if the speakers and amplifier cannot handle wide dynamic range, and if the expander "tries" to drive them to a wide dynamic range, excessive clipping distortion (overdrive) may occur. To avoid this unpleasant effect, use good speakers and a reasonably large amplifier. If distortion still occurs, it will probably be noticed only with programs that have a good dynamic range to begin with, and which do not need expansion to much greater dynamics. In such cases, a reduction in the transition level and the expansion ratio setting will avoid distortion. A good expander is a powerful tool, and, as with any powerful tool, it can be used to excess. Used properly, the expander can turn an old record collection into a treasure of new listening enjoyment, and it can turn a boring selection of compressed and limited FM broadcasts into an exciting new source of listening pleasure.

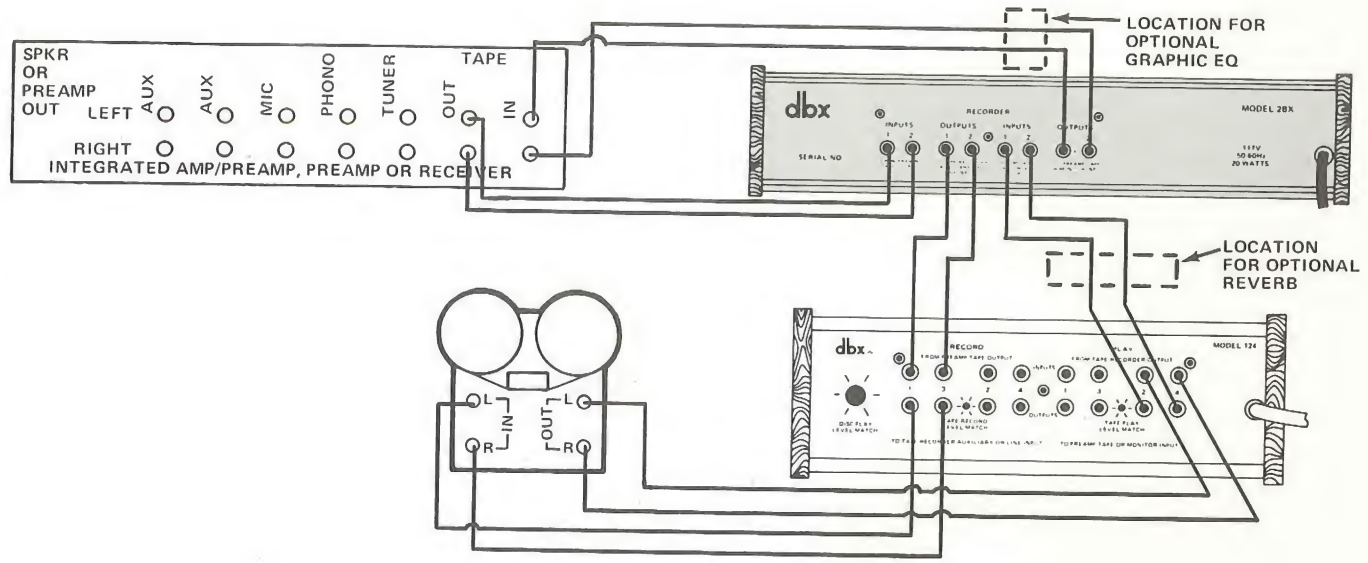

Fig. 4 - Combining the 2BX with a dbx Tape Noise Reduction System



## HOW dbx EXPANDERS WORK

10

### Dynamic Range

Dynamic range is the difference in level between the loudest and the quietest portions of a program, expressed in dB\*. Since the quietest parts of a recorded program are usually restricted by noise, the dynamic range of a recording is usually defined as the difference in level (in dB) between the loudest parts of the program and the noise level.

### Restricting Dynamic Range

The loudest sounds in a live performance may reach 120dB SPL. The quietest sounds, however, will not be heard if they are much quieter than the ambient room noise (people coughing, air conditioning or other noises). The ambient room noise in a very quiet auditorium is somewhat over 30dB SPL. The useable dynamic range of a live performance is therefore derived by subtracting the room noise (30dB SPL) from our tolerance of extremely loud sounds (120dB SPL), giving a maximum of about 90dB. Recording studios have less room noise and a dynamic range of over 100dB can be realized.

The dynamic range of a recorded program is purposely restricted to far less than 100dB in order to fit within the dynamic range limitations of the recording or broadcast medium. For example, the dynamic range of a studio quality tape recorder is about 65dB. Tape noise restricts the quietest sounds that can be recorded, and tape

*\*The "dB" or "decibel" is a unit of expression for sound level or intensity of sound. One decibel is usually described as the smallest detectable change in sound level. The threshold of human hearing (the faintest sound you can perceive at a midrange frequency of 1000Hz) is approximately "0dB SPL" (Sound Pressure Level) and the threshold of pain (the point at which you instinctively put your hands over your ears) is about 120dB SPL. Some people can tolerate 130dB SPL, others leave the room when the sound level reaches 110dB. The difference between the "threshold of human hearing" and the "threshold of pain" is the dynamic range of human hearing (120dB).*

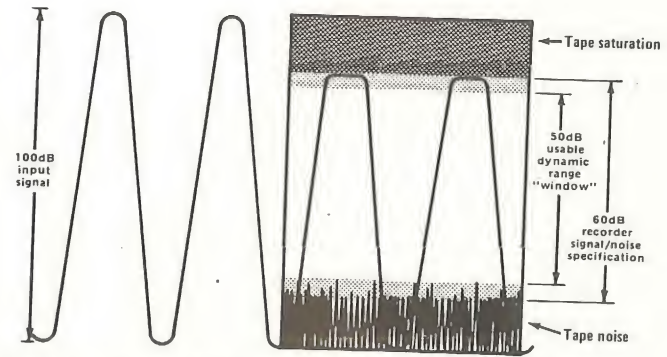

**Fig.5 — Dynamic Range Limitations of the Tape Recording Process.**  
NOTE: The waveform is not a sinewave signal; it is the "envelope" describing the program's volume changes.

saturation (distortion) restricts the loudest sounds that can be recorded. Home tape recorders, especially cassette and cartridge recorders, have an even more restricted dynamic range . . . often only 50dB. (dbx tape noise reduction systems can nearly double the dynamic range capabilities of any tape recorder.)

The maximum dynamic range of only the very best phonograph discs is about 65dB, and this is seldom achieved (see footnote on next page). The quietest sounds on a disc are restricted by the "grain" of the vinyl, and other surface irregularities that create noise; the loudest sounds are restricted by the maximum excursion of the groove. Loud levels are also restricted by the ability of the phonograph needle to "track" the record. To allow more playing time per side, the dynamic range of many records is often restricted to less than 50dB.



The dynamic range capability of a radio program is about 60dB for FM broadcasts, or 50dB for AM broadcasts. The quietest sounds are restricted by broadcast interference and noise, like FM hiss; the loudest sounds are limited by the maximum allowable modulation of the transmitter (100%). Above 100% modulation, the transmitted signal would be distorted, and the station would interfere with adjacent radio stations, near the same radio frequency. Compression is used to prevent overmodulation and to raise the average level, thus raising apparent loudness, so that most broadcasts have much less than 50 or 60dB dynamic range . . . popular AM stations often compress the program to average less than 10dB dynamic range.

**NOTE:** By using dbx II noise reduction during the manufacture of phonograph discs, the dynamic range can be extended to 100dB. Surface noise is reduced to inaudibility and the full dynamics of a performance can be captured. dbx-encoded discs are commercially available, and can be decoded with any of the dbx 120 and 140 series noise reduction systems.

#### Compression and Limiting

Compression and limiting are the electronic techniques used to reduce the dynamic range of a live program to fit within the restrictions of the recording or broadcast medium. A *compressor* may be a *LINEAR COMPRESSOR*: such a device increases the level of quiet passages, and decreases the level of loud passages. The *COMPRESSION RATIO* is the ratio in dB of the compressor's input dynamic range to its output dynamic range. For example, if the compression ratio is 2:1, the output level will only change 1dB for every 2dB change at the input (thus restricting, or "compressing" the dynamic range). The *THRESHOLD* is the level at which

the compressor decides to increase or decrease levels. The compressor decreases the level of input signals that are above the threshold, and increases the level of input signals that are below the threshold. Those which act only on levels that are above the threshold level, and let any signal that is below the threshold pass unchanged are called *ABOVE THRESHOLD COMPRESSORS*. A *LIMITER* is an above threshold compressor that has a compression ratio of 10:1 or higher. The threshold of a limiter is usually adjusted so that it acts only on musical peaks, preventing them from exceeding the threshold by more than a very small margin.

The restriction of dynamic range created by compression and/or limiting is undesirable because it removes much of the excitement from a recorded performance. However, without this restriction, the quietest parts of the program could be lost in noise, and the loudest parts of the program could be severely distorted. Fortunately, there are ways to overcome this dynamic range restriction, by restoring "lost" program dynamics.

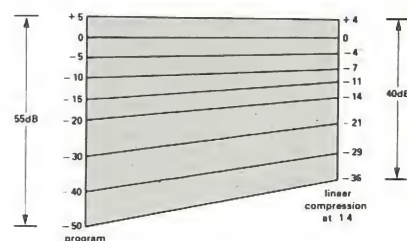
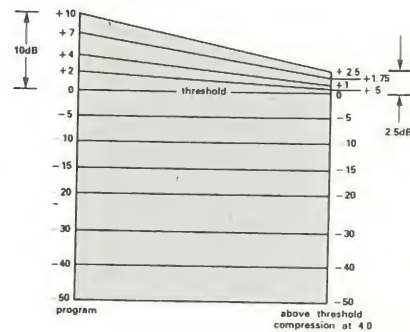

Fig. 6 – Linear Compression Linear compression reduces the entire dynamic range of the music irrespective of input signal level.



**Fig. 7 — Above Threshold Compression** Above threshold compression has no effect on low level signals. When signal level reaches the adjustable threshold, the dynamic content of the music is decreased but only above that threshold. Higher compression ratios may be used in above threshold compression than in linear compression; however, all ratios are available. This is known as limiting if the compression ratio is 10:1 or higher.

#### dbx Expanders

An *EXPANDER* is a device that decreases the level of quiet musical passages, and increases the level of loud musical passages. It is the opposite of a compressor. The *EXPANSION RATIO* is the ratio of the expander's input dynamic range to its output dynamic range. An expander with a 1:1.4 expansion ratio will have an output level change of 1.4dB for an input level change of 1.0dB. Given an expander with an expansion ratio of 1:1.4, and an input program that has a dynamic range of 60dB, the output dynamic range will be  $(60 \times 1.4 = 84)$  or 84dB. The *TRANSITION LEVEL* (threshold) is the level at which the expander decides whether to increase or decrease

program levels. When an input signal is above the threshold, the expander increases its level; when an input signal is below the threshold, the expander decreases its level.

All expanders have a level detection circuit. This detection circuit is used to sense the input signal level and to determine whether it is above or below the threshold. However, the method used to detect input signal level is different on various expanders. The detection technique is vital, as detailed below.

#### Peak Detection

Some expanders sense musical peaks in the input signal to determine whether the input signal level is above or below the threshold. The effect of this peak detection is that the expander acts somewhat erratically, and may expand the program when it detects a noise spike or brief musical transient that isn't really representative of the program level.

#### Average Detection

Some expanders sense the average level of the incoming program to determine whether the signal is above or below the threshold. Average detection circuits will not overreact on musical peaks, but may respond too slowly to accurately expand a program. The expander may respond too late to a rapid increase in program level after the actual input signal has begun to decrease again, causing an unnatural or swishing sound.

#### RMS Detection

The 2BX uses RMS detection, which acts on the RMS (Root-Mean-Square) value of the input signal. RMS detection is different from either peak or average detection. An RMS detection circuit will not overreact on musical transients or noise spikes, yet it responds quickly to significant musical transients. In fact, the human ear judges

sound levels by their RMS values, which means that the RMS detection circuit in the 2BX electronically parallels the way the human ear hears music. Until recently, however, RMS detection was very complex and costly. dbx has pioneered the development of moderately priced RMS detection circuitry, and has led the industry in applying RMS detection to expanders, compressor/limiters and tape noise reduction systems.

#### Linear dB Expansion

Once the signal has been "detected," the expander knows when to increase or decrease its level. The circuit that actually performs this level change is known as a "voltage controlled amplifier" or "VCA." The "AVC" (automatic volume control), and "ALC" (automatic level control) on many cassette recorders are examples of voltage controlled amplifiers, as are the level changing circuits in any modern expander, compressor or limiter. The voltage from the detection circuit increases or

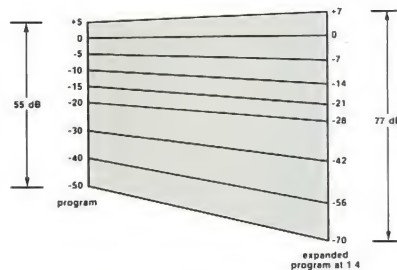

**Fig. 8 — Linear Expansion** Linear Expansion operates over the entire dynamic spectrum of music irrespective of input signal level, making loud passages louder and quiet passages quieter, reducing audible noise. Expansion ratios are adjustable. For example: 1.0 = 0% increase in dynamic range; 1.2 = 20%; 1.5 = 50%; 2.0 = 100%.

decreases the gain of the VCA which increases or decreases the level of the program. While some expanders may increase or decrease the program level by a fixed amount, the 2BX increases or decreases the level of the program on a "linear decibel" basis. This means that the output dynamic range and the input dynamic range are linearly related by the "expansion ratio" over the entire dynamic range (as described earlier) for a smooth, natural sound.

#### Attack and Release Times

The expander must decide how fast to react to changes in program level. The length of time between an increase in input signal level and its corresponding expansion is known as the *ATTACK TIME*. After the expansion of an input signal, the expander allows the input signal to return to its normal level. The amount of time to return to normal is known as *RELEASE TIME*. These terms also apply for compressors and limiters.

Different attack and release times are desirable for different types of music. For example, a smooth classical string quartet may sound best when expanded with a slow attack and release time. Other programs may sound best with faster attack and release times. The point is that the attack and release times should be allowed to vary according to the program content for the most natural sound. The 2BX does just that.

The 2BX's attack and release times automatically and continuously follow the rate of change of the "envelope" of the program.\* In fact, because they are not fixed, the 2BX's release times are specified as *rates* which change in response to different program envelopes. Furthermore, the attack and release rates are scaled differently in each of the

\*The envelope is a graph of the program level versus time.



2BX's two frequency bands, to provide an expansion characteristic that best suits the music. The result is a smooth action that does not alter the character of the music as dynamics are expanded and noise is lowered.

#### dbx Tape Noise Reduction

dbx tape noise reduction systems allow a program of up to 100dB dynamic range to be recorded on tape (or on an encoded phonograph disc) without losing the quiet passages in the noise or distorting the loud passages. Professional

recording studios throughout the world are using dbx professional tape noise reduction systems, and dbx has become the new established leader in the field. dbx II noise reduction systems, such as our 120 series, are available for use by the audiophile and home recordist. Like the original dbx tape noise reduction system, dbx II noise reduction systems make it possible to tape record up to 100dB of dynamic range, and in addition, dbx II noise reduction systems also facilitate playback of special dbx encoded discs (see footnote, page 11).

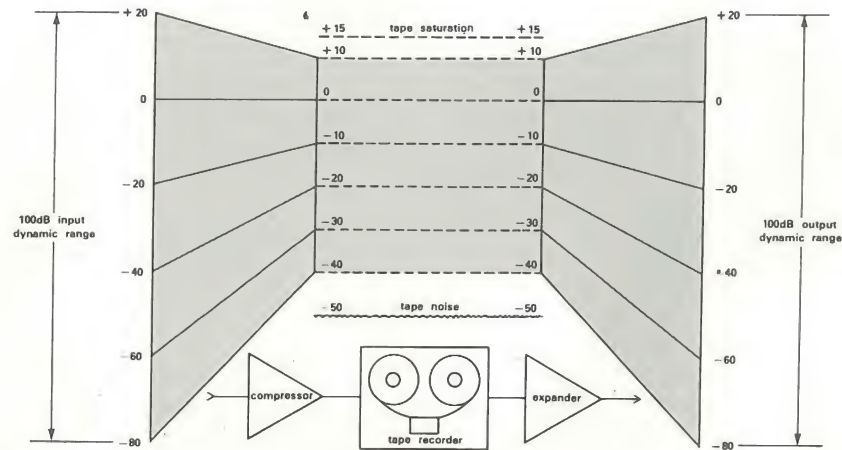

Fig. 9 — dbx Tape Noise Reduction Loud passages are decreased in level allowing them to be recorded below the level of tape saturation; very quiet signals are placed on tape significantly above the tape noise level.



## SPECIFICATIONS

15

|                                    |   |
|------------------------------------|---|
| <b>EXPANSION RATIO</b>             | 1.0 to 1.5 (0 to 50% increase), linear in decibels  |
| <b>DYNAMIC RANGE</b>               | 110dB (peak signal to weighted background noise ratio)  |
| <b>TRANSITION LEVEL RANGE</b>      | 30mV to 3V (threshold)  |
| <b>ATTACK AND RELEASE RATES</b>    | Variable, determined by program loudness and rate of change   |
| <b>FREQUENCY RESPONSE</b>          | $\pm 0.5$ dB, 20Hz to 20kHz at an expansion ratio of 1:1.0  |
| <b>TOTAL HARMONIC DISTORTION</b>   | 0.1% typical at 1.0 expansion, 20Hz to 20kHz  |
| <b>IM DISTORTION</b>               | 0.15% typical   |
| <b>INPUT IMPEDANCE</b>             | High (50 kohms)   |
| <b>OUTPUT IMPEDANCE</b>            | Low (the 2BX is designed to feed a tape monitor input or tape deck with long cables)  |
| <b>MAXIMUM OUTPUT LEVEL</b>        | 6 volts RMS at 1kHz   |
| <b>CONTROLS</b>                    | Interlocking Tape & Source switches, Interlocking Pre & Post switches, Power ON/OFF, Transition Level, Expansion  |
| <b>INDICATORS</b>                  | Power ON L.E.D., (10) Gain Change L.E.D.'s for each of 2 bands (20 total)   |
| <b>CONNECTORS</b><br>(Phono jacks) | FROM PREAMP TAPE OUTPUT (x 2)<br>TO TAPE RECORDER AUXILIARY OR LINE INPUT (x 2)<br>FROM TAPE RECORDER OUTPUT (x 2)<br>TO PREAMP TAPE OR MONITOR INPUT (x 2) |
| <b>POWER REQUIREMENTS</b>          | 117V AC, 50 or 60Hz.  |
| <b>POWER CONSUMPTION</b>           | 20 watts, maximum   |
| <b>DIMENSIONS</b>                  | 17-3/4" W x 3-3/4" H x 10-1/2" D<br>(45.1cm W x 9.5cm H x 26.7cm D)   |
| <b>WEIGHT</b>                      | 8 lbs., 5 oz. (3.8 kg)  |

Specifications subject to change without notice or obligation.

**dbx PRODUCT WARRANTY**

All dbx products are covered by a limited warranty. Consult your warranty card or your local dealer for full details.

**FACTORY SERVICE**

The dbx Customer Service Department is prepared to give additional assistance in the use of the product. All questions regarding interfacing dbx equipment with your system, service information or information on special applications will be answered. You may call during normal business hours — Telephone: 617-964-3210, Telex: 92-2522, or write to:

**dbx, Inc.**  
**71 Chapel Street**  
**Newton, MA 02195**  
**Attn: Customer Service Department**

Should it become necessary to have your equipment factory serviced:

1. Please repack the unit, including a note describing the problem along with the day, month and year of purchase.

2. Send the unit, freight prepaid, to:

**dbx, Inc.**  
**224 Calvary Street**  
**Waltham, MA 02154**  
**Attn: Repair Department**

3. We recommend that you insure the package and send it via United Parcel Service wherever possible.

4. Please direct all inquiries to dbx Customer Service Department.

Outside the U.S.A. — contact your nearest dbx dealer for the name and address of the nearest authorized repair center.

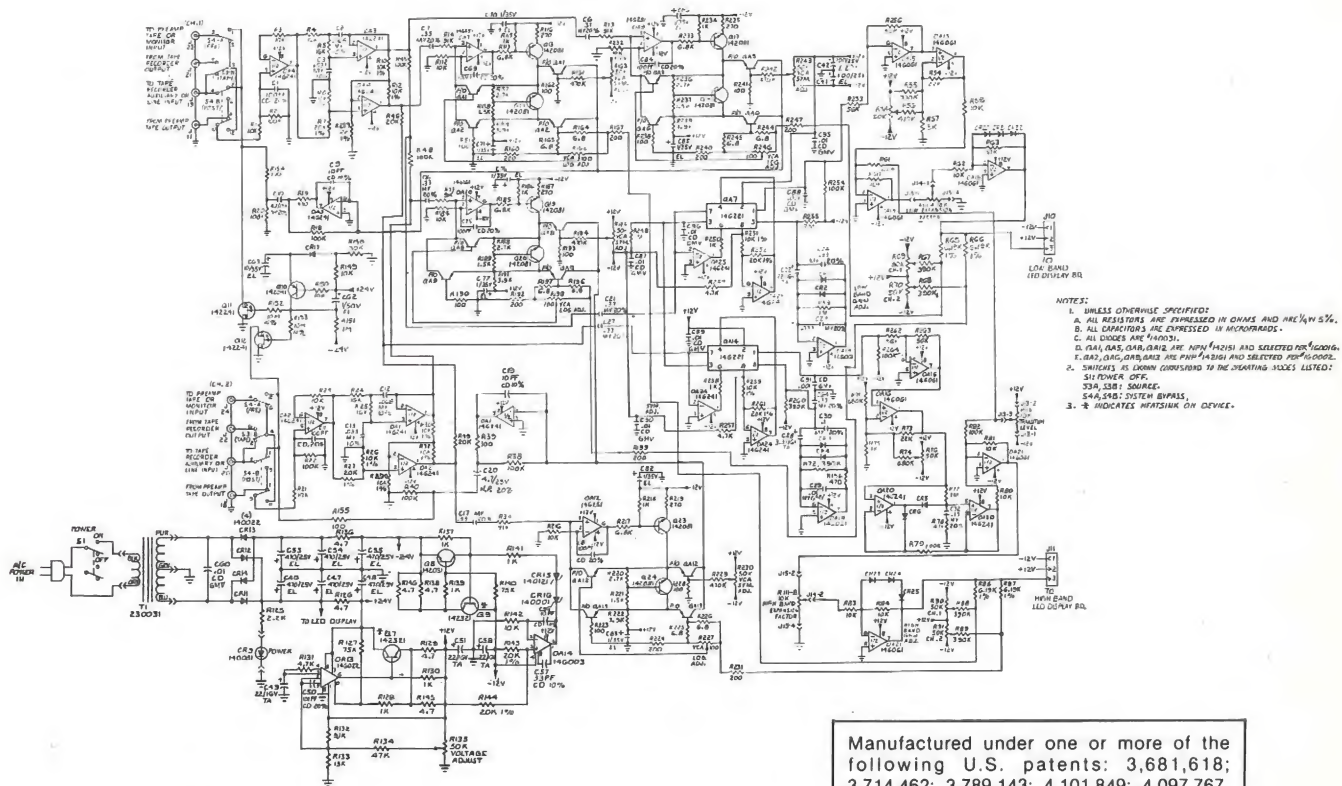

Manufactured under one or more of the following U.S. patents: 3,681,618; 3,714,462; 3,789,143; 4,101,849; 4,097,767. Other patents pending.

NOTES



**Asperity Noise**

This is a swishing type of background noise that occurs with tape recordings in the presence of strong low frequency signals, especially when there are no high frequency signals to mask the hiss. Asperity noise is caused by minute imperfections in the surface of the tape, including variations in the magnetic particle size in the tape's oxide coating. The imperfections increase or decrease the strength of the magnetic field passing the play head in a random manner, resulting in audible noise. Asperity noise may be present even when no program is recorded. When a program is recorded, asperity noise becomes superimposed on the signal, creating modulated asperity noise, or "modulation noise." Using high-quality tape with a calendered surface helps reduce asperity and modulation noise (calendered tape is pressed smooth by high-pressure rollers).

**Attack Time**

Attack time may mean different things, depending on the context. In music, the time it takes for a note to reach its full volume is the attack time of the note. Percussive instruments have short attack times (reach maximum volume quickly) and wind instruments have long attack times (reach maximum volume more gradually).

When a compressor (or expander) changes the level of an incoming signal, the circuitry actually requires a finite amount of time to complete that change. This time is known as the attack time. More precisely, the attack time is the interval (usually measured in milliseconds or microseconds) during which the compressing or expanding amplifier changes its gain from the initial value to 63% of the final value.

**Aux Input (Aux Level)**

Aux inputs, an abbreviation for auxillary inputs, are low sensitivity jacks provided on most hi-fi and semi-professional equipment. Aux inputs (also known as "aux level" or "line level" inputs) have "flat" frequency response and are intended to be used with preamplified signals. Aux-level (line-level) signals are medium-level, higher than microphone levels, but not enough power to drive a speaker. The advantage to these levels is that they are less susceptible to hum and noise than are microphone levels. Typical items which might be connected to aux inputs are tape machine "play" outputs, tuner outputs, and dbx "play" outputs. Mic-level or phono-level signals are considerably lower in level than aux inputs (approx. -60 to -40dBV), so they will not produce adequate volume when connected to an aux input. Moreover, phono cartridge outputs require RIAA equalization which is not provided by aux inputs.

**Bandwidth**

Bandwidth refers to the "space" between two specific frequencies which are upper and lower limits; alternately, bandwidth refers to the absolute value of the range of frequencies between those limits. Thus, a filter which passes frequencies from 1,000Hz to 10,000Hz may be said to have a bandwidth of 1kHz-10kHz, or it may be said to have a 9kHz bandwidth (10kHz minus 1kHz equals 9kHz).

Bandwidth is not necessarily the same as frequency response. Bandwidth may be measured at low levels, and frequency response at higher levels. Moreover, bandwidth may refer only to certain portions of the circuitry within a piece of equipment, whereas frequency response may refer to the overall performance of the equipment. Thus, while the overall input-to-output frequency response of dbx type II equipment is 20Hz to 20kHz, the bandwidth of the RMS detection circuitry within that equipment is 30Hz to 10kHz.

**Bass**

The low audio frequency range below approximately 500Hz. For the purpose of discussion or analysis, the bass range may be further divided into upper bass (250 to 500Hz), mid bass (100-200Hz), low bass (50-100Hz), and ultra-low bass (20-50Hz).

**Bass Boost**

An accentuation of the lower audio frequencies (bass frequencies), whereby they are made louder than other frequencies.

**Bi-amplified**

Descriptive of a sound system which utilizes a low level cross-over network to divide the full-spectrum audio signal into low and high frequency ranges. These ranges are then fed to separate power amplifiers, which in turn feed low frequency speakers (woofers) and high frequency speakers (tweeters).

**Bias**

Bias, as the term is used in tape recording, is a very high frequency signal (usually over 100kHz) that is mixed with the program being recorded in order to achieve linear magnetization of the tape. If only the audio program were applied to the recording head, a very distorted recording would result because lower-energy portions of the program would not be able to overcome the initial magnetization threshold of the tape (known as hysteresis).

The frequency of the bias signal is not critical, so long as the record and erase bias are synchronized. However, the bias

energy level has a direct effect on the recorded level, background noise, and the distortion. It is sometimes necessary to reset the bias level for optimum performance with different types of recording tape, and professional tape machines are equipped with continuously variable bias controls; many consumer tape machines are now equipped with bias selector switches.

#### Clipping

Clipping is a very distorted sound. It occurs when the output capabilities of an amplifier are exceeded, and the amp can no longer produce any more voltage, regardless of how much additional gain or how much more input signal is present. Clipping is relatively easy to see on an oscilloscope, and it is sometimes audible as an increase in harmonic distortion. In severe cases of clipping (hard clipping), sine waves begin to resemble square waves, and the sound quality is very poor. Often, the maximum output level of an amplifier is defined as that level where clipping begins to occur. There is a phenomenon known as input clipping, and this may occur where the input signal is so high in level that it exceeds the level-handling ability of the transformer and/or of the input amplifier. Clipping also occurs when tape is saturated by excessive record levels.

So-called "soft clipping" is usually the result of transformer saturation, and it may be somewhat less objectionable than the "hard clipping" that occurs when output voltage limits are reached. Aside from degrading the sound quality, clipping can damage loudspeakers. Output clipping may be avoided by reducing the level of the input signal, reducing the gain of the amplifier, or using a larger amplifier. Input clipping may be avoided by reducing the level of the incoming signal, and then increasing the gain of the amplifier.

#### Clipping Level

This is the signal level at which clipping just begins to occur. Clipping level is not always easy to define. It may be a matter of visually judging the waveform on an oscilloscope as the level is increased; alternately, clipping level may be defined as the level at which harmonic distortion reaches a given value. Tape clipping, or saturation, is defined as the 3% harmonic distortion level.

#### Compression

Compression is a process whereby the dynamic range of program material is reduced. In other words, the difference between the lowest and highest audio levels is "squeezed" into a smaller dynamic range. A compressed signal has higher average level, and therefore may have more apparent loudness than an uncompressed signal, even though the peaks are no higher in level. Compression is

achieved with a compressor, a special type of amplifier that decreases its gain as the level of the input signal increases. The amount of compression is expressed as a ratio of the input dynamic range to the output dynamic range; thus, a compressor that takes a program input with 100dB of dynamic range and yields an output program of 50dB dynamic range may be said to have a 2:1 compression ratio.

#### Compressor

A compressor is an amplifier that decreases its gain as the level of the input signal increases to reduce the dynamic range of the program (see "compression"). A compressor may operate over the entire range of input levels, or it may operate only on signals above and/or below a given level (the threshold level).

#### Crossover Frequency

In loudspeaker systems and multi-amplifier audio systems, the transition frequency (actually a frequency range) between bass and midrange or midrange and treble speakers or amplifiers.

#### Crossover Network

A circuit which divides the audio spectrum into two or more frequency bands for distribution to different speakers (high level crossover) or different amplifiers which then feed different speakers (low level crossover).

High level crossovers are usually built into the speaker cabinet, and are passive (they require no power supply). Low level crossovers are used in bi-amplified or tri-amplified sound systems. They are usually self-contained, and come before the power amplifiers. Low level crossovers may be passive or active; active low level crossovers are known as "electronic crossovers."

#### Damping Factor

The ratio of loudspeaker impedance to the amplifier's output source impedance. Damping describes the amplifier's ability to prevent unwanted, residual speaker movement. The higher the numerical value, the better the damping.

#### DB (Decibel) also, dBv dBV dB SPL dBm dB

One dB is the smallest change in loudness the average human ear can detect. 0dB SPL is the threshold of human hearing whereas the threshold of pain is between 120 and 130dB SPL. The term dB is an abbreviation for decibel, or 1/10 of a Bel. The decibel is a ratio, not an absolute number, and is used to express the difference between two power, voltage or sound pressure levels. (dB is 10 times the logarithm of a power ratio or 20 times the logarithm of a voltage



or sound pressure ratio.) if the number of "dB's" are referenced to a given level, then the value of the dB number becomes specific.

**dBV** expresses a voltage ratio. 0dBV is usually referenced to 1.0V RMS. Thus 0dBV=1V RMS, +6dBV=2V RMS, +20dBV=10V RMS, etc.

**dB SPL** expresses a Sound Pressure Level ratio. dB SPL is a measure of acoustic pressure (loudness), not acoustic power, which would be measured in acoustic watts. 0dB SPL is equal to 0.0002 dynes/square centimeter (the threshold of human hearing at 1kHz). As with dBV, an increase of 6dB SPL is twice the sound pressure, and an increase of 20dB SPL is an increase of 10 times the sound pressure.

**dBm** expresses a power ratio. 0dBm is 1 milliwatt (.001 watts), or 0.775V rms delivered to a 600-ohm load. +3 dBm=2 milliwatts, or 1.096V into 600 ohms ( $\sqrt{2}$  times 0dBm), +10dBm=10 milliwatts, or 2.449V into 600 ohms (3.16 times 0dBm), etc. dBV and dBm differ by 2.21 when dealing with 600-ohm circuits. However, when the impedance is other than 600 ohms, the value of dBV remains the same if the voltage is the same, whereas the value of dBm decreases with increasing impedance.

**dB** alone, without any suffix, doesn't mean anything unless it is associated with a reference. It may express the difference between two levels. Thus, the difference between 10dBV and 15dBV, the difference between 0dBm and 5dBm, and the difference between 90dB SPL and 95dB SPL are all differences of 5dB.

#### Decay Time

Decay time may mean different things, depending on the context. A compressor's decay time is also known as its release time or recovery time. After a compressor (or expander) changes its gain to accommodate an incoming signal, and the signal is then removed, the decay time is the amount of time required for the circuitry to return to "normal." More precisely, the decay time is the interval (usually measured in microseconds or milliseconds) during which the compressing or expanding amplifier returns to 90% of the normal gain. Very fast decay times can cause "pumping"

or "breathing" effects, whereas very slow decay times may cause moderate-level program which follows high-level program or program peaks to be too low in level.

#### Decoder

When a circuit restores an original program from a specially treated version of that program, the circuit may be said to decode the program. The equipment or circuit which performs this function is known as a decoder. Decoders must be used only with programs which have been encoded by complementary encoding circuitry. Typical decoders include: FM tuners that use multiplex decoders to extract left and right stereo signals from left-plus-right and left-minus-right signals, matrix quadrasonic decoders that extract four channels of program from the stereo program on encoded recordings, and dbx decoders that retrieve wide-dynamic range programs from the compressed programs on dbx-encoded recordings.

#### De-emphasis & Pre-emphasis

De-emphasis and pre-emphasis are related processes that are usually done to avoid audio noise in some storage or transmission medium. Pre-emphasis is a boost at specific higher frequencies, the encoding part of an encoding/decoding system. De-emphasis is an attenuation at the same frequencies, a reciprocal decoding that counteracts the pre-emphasis. In dbx noise reduction, de-emphasis is performed by the decoder (the play circuitry). The de-emphasis attenuates high frequencies, thereby reducing tape modulation noise and restoring the original frequency response of the program before it was dbx encoded. There are other types of pre-emphasis and de-emphasis. For example, in FM tuners, de-emphasis is used to compensate for special equalization (known as 75-microsecond pre-emphasis) applied at the station's transmitter.

#### Dynamic Range

The dynamic range of a program is the range of signal levels from the lowest to the highest level. In equipment, the dynamic range is the "space," in dB, between the residual noise level and the maximum undistorted signal level. A program with wide dynamic range has a large variation from the softest to the loudest passages, and will tend to be more lifelike than programs with narrow dynamic range.

#### Encoder

When a circuit processes an original program to create a specially treated version of that program, the circuit may be said

to encode the program. The equipment or circuit which performs this function is known as an encoder. Encoded programs must be decoded only with complementary decoding circuitry. Typical encoded programs include: FM multiplex broadcasts, matrix quadrasonic recordings, and dbx encoded recordings.

#### Envelope

In music, the envelope of a note describes the change in average signal level from initial attack, to peak level, to decay time, to sustain, to release time. In other words, the envelope describes the level of the note as a function of time. Envelope does not refer to frequency.



The outline is the envelope,  
the signal is within the envelope.

In fact, any audio signal may be said to have an envelope. While all audio frequencies rise and fall in instantaneous level from 40 to 40,000 times per second, an envelope may take many milliseconds, seconds or even minutes to rise and fall. In dbx processing, the envelope is what "cues" the rms level detection circuitry to compress and expand the signal; the peak or average level of individual cycles of a note would be useless for level detection because the gain would change much too rapidly for audibly pleasing sound reproduction.

#### EQ (Equalization)

EQ or equalization, is an intentional change in the frequency response of a circuit. EQ may be used for boosting (increasing) or cutting (decreasing) the relative level of a portion of the audible spectrum. Some EQ is used for achieving sound to suit personal listening tastes, while other types of EQ are specifically designed to correct for non-linearities in the system; these corrective EQ "curves" include tape (NAB or CCIR) equalization, and phonograph (RIAA) equalization. In a sense, the pre-emphasis and de-emphasis used in dbx processing are special forms of equalization.

There are two common types of EQ equalization curves (characteristics): PEAKING and SHELIVING. Shelving EQ is used in most Hi-Fi bass and treble tone controls. Peaking EQ is used in Hi-Fi midrange tone controls, in graphic equalizers, and many types of professional sound mixing equipment.

EQ is performed by an equalizer, which may be a specially built piece of equipment, or it may be no more than the tone control section of an amplifier. Graphic equalizers have many controls, each affecting one octave, one-half octave, or one-third octave of

the audio spectrum. (An octave is the interval between a given tone and its repetition eight tones above or below on the musical scale; a note which is an octave higher than another note is twice the frequency of the first note.)

#### Expander

An expander is an amplifier that increases its gain as the level of the input signal increases, a characteristic that "stretches" the dynamic range of the program (see "expansion"). An expander may operate over the entire range of input levels, or it may operate only on signals above and/or below a given level (the threshold level).

#### Expansion

Expansion is a process whereby the dynamic range of program material is increased. In other words, the difference between the lowest and highest audio levels is "stretched" into a wider dynamic range. Expansion is sometimes used to restore dynamic range that has been lost through compression or limiting done in the original recording or broadcast; expansion is an integral part of compander-type noise reduction systems, including dbx. Expansion is achieved with an expander, a special type of amplifier that increases its gain as the level of the input signal increases. The amount of expansion is expressed as a ratio of the input dynamic range to the output dynamic range; thus, an expander that takes a program input with 50dB of dynamic range and yields an output program of 100dB dynamic range may be said to have a 1:2 compression ratio.

#### Fundamental

A musical note is usually comprised of a basic frequency, plus one or more whole-number multiples of that frequency. The basic frequency is known as the fundamental, and the multiples are known as harmonics or overtones. A pure tone would consist of only the fundamental.

#### Ground Compensated Output

This is a sophisticated output circuit that senses the potential difference between the ground of the dbx unit and the shield ground of unbalanced inputs to which the dbx unit is connected. Ideally, the dbx unit and the input of the following device should be at the same level (potential). However, where grounding is not "right" (where so-called "ground loops" exist), this circuit calculates the ground error and adds a correction signal to the high side of the output, thereby cancelling much of the hum, buzz and noise that might otherwise have been introduced by ground loops.



### Harmonic Distortion

Harmonic distortion consists of signal components appearing at the output of an amplifier or other circuit that were not present in the input signal, and that are whole-number multiples (harmonics) of the input signal. For example, an amplifier given a pure sine-wave input at 100Hz may produce 200Hz, 300Hz, 400Hz, 500Hz, 600Hz and even 700Hz energy, plus 100Hz, at its output (these being the 2nd, 3rd, 4th, 5th, 6th and 7th order harmonics). Usually, only the first few harmonics are significant, and even-order harmonics (i.e. 2nd and 4th) are less objectionable than odd-order harmonics (i.e. 3rd and 5th); higher harmonics may be negligible in comparison to the fundamental (100Hz) output. Therefore, rather than specifying the level of each harmonic component, this distortion is usually expressed as T.H.D. or Total Harmonic Distortion. While T.H.D. is the total power of all harmonics generated by the circuitry, expressed as a percentage of the total output power, the "mixture" of different harmonics may vary in different equipment with the same T.H.D. rating.

### Harmonics

Overtone which are integral multiples of the fundamental.

### Headroom

Headroom refers to the "space," usually expressed in dB, between the nominal operating signal level and the maximum signal level. The input headroom of a circuit that is meant to accept nominal -10dB levels, but can accept up to +18dB without overdrive or excessive distortion, is 28dB (from -10 to +18 equals 28dB). Similarly, the output headroom of a circuit that is meant to supply nominal +4dBm drive levels, but that can produce +24dBm before clipping is 20dB. A circuit that lacks adequate headroom is more likely to distort by clipping transient peaks, since these peaks can be 10 to 20dB above nominal operating signal levels.

### I.M. (Intermodulation Distortion)

Intermodulation distortion consists of signal components appearing at the output of an amplifier or other circuit that were not present in the input signal, that are not harmonically related to the input, and that are the result of interaction between two or more input frequencies. I.M. distortion, like harmonic distortion, is usually rated as a percentage of the total output power of the device. While some types of harmonic distortion are musical, and not particularly objectionable, most I.M. distortion is unpleasant to the ear.

### Impulse Response

Related to the rise time of a circuit, the impulse response is a measurement of the ability of a circuit to respond to sharp sounds, such as percussion instruments or plucked strings. A circuit with good impulse response would tend to have good transient response.

### Level Match

The dbx noise reduction system is unlike competitive systems in that there is no one threshold at which compression or expansion begins. Instead, compression occurs linearly, with respect to decibels, over the full dynamic range of the program. By necessity, there is an arbitrary signal level which passes through the encoder and decoder without being changed in level. This level is known as the level match point (transition point). Some dbx equipment provides for user adjustment of the level match point, for monitoring purposes only. Although this is not necessary for proper encode/decode performance, by setting the level match point to be approximately equal to the nominal (average) signal level, there will be no increase or decrease in level as you switch from monitoring "live" program to monitoring dbx-processed program.

### Limiter

A limiter is a type of compressor, one with a 10:1 or greater compression ratio. A limiter with a high compression ratio (120:1) can be set so that no amount of increase in the input signal will be able to raise the output level beyond a preset value. The difference between limiting and compression is that compression gently "shrinks" dynamic range, whereas limiting is a way to place a fixed "ceiling" on maximum level, without changing the dynamic range of program below that "ceiling," or threshold.

### Line Level (Line Input)

Line level refers to a preamplified audio signal, in contrast to mic level, which describes a lower-level audio signal. The actual signal levels vary. Generally, mic level is nominally -50dBm (with typical dynamic range of -64dBm to +10dBm). Line level signals vary, depending on the audio system. Hi-Fi line levels are nominally -15dBV, whereas professional line levels are nominally +4dBm or +8dBm (with typical dynamics ranging from -50dBm to +24dBm).

Line inputs are simply inputs that have sensitivities intended for line level (preamplified) signals. Often, the nominal impedance of a line level input will be different than the nominal impedance of a mic level input.

**Modulation Noise**

Modulation noise is a swishing type of background hiss that occurs with tape recordings in the presence of strong low frequency signals. The noise depends on the level of the recorded signal; the higher the recorded signal level, the higher the modulation noise. Modulation noise has typically been "masked," hidden by the dominant signal and/or by the background hiss of the tape. However, when the background hiss is removed, as with dbx processing, modulation noise could become audible. This would happen primarily with strong, low-frequency signals, but in fact it is minimized by dbx's pre-emphasis and de-emphasis.

**Octave**

In music or audio, an interval between two frequencies having a ratio of 2:1.

**Overshoot**

When a compressor or expander changes its gain in response to a fast increase or decrease in level, the maximum gain change should be directly proportional to the actual signal level. However, in some compressors the level detection and gain changing circuitry develop a kind of "inertia," over-reacting to changes in level, increasing or decreasing the gain more than the fixed ratio asked for. This over-reaction is known as overshoot, and it can cause audibly non-linear compression (distortion). dbx circuits have minimal overshoot, so they provide highly linear compression and expansion.

**Peak Level**

An audio signal continuously varies in level (strength, or maximum voltage) over any period of time, but at any instant, the level may be higher or lower than the average. The maximum instantaneous value reached by a signal is its peak level (see RMS level).

**Phase Shift**

"Time shift" is another way to describe phase shift. Some circuitry, such as record electronics and heads, will delay some frequencies of an audio program with respect to other portions of the same program. In other words, phase shift increases or decreases the delay time as the frequency increases. On an absolute basis, phase shift cannot be heard, but when two signals are compared to one another, one having a phase shift relative to the other, the effects can be very noticeable, and not very desirable. Excessive phase shift can give a tunnel-like quality to the sound. Phase shift also can degrade the performance of compander type noise

reduction systems which depend on peak or average level detection circuitry.

**Power Amplifier**

A unit that takes a medium-level signal (e.g., from a pre-amplifier) and amplifies it so it can drive a loudspeaker. Power amplifiers can operate into very low impedance loads (4-16 ohms), whereas preamplifiers operate only into low impedance (600 ohms) or high impedance (5,000 ohms or higher) loads. Also known as a main amplifier, the power amplifier may be built into an integrated amplifier or a receiver.

**Preamplifier**

A device which takes a small signal (e.g., from a microphone, record player), or a medium-level signal (e.g., from a tuner or tape recorder), and amplifies it or routes it so it can drive a power amplifier. Most preamplifiers incorporate tone and volume controls. A preamp may be a separate component, or part of an integrated amplifier or of a receiver.

**Pre-Emphasis** (See "de-emphasis")

**Receiver**

A single unit that combines tuner, preamp and power amplifier sections.

**Release Time or Release Rate** (See "decay time" and "attack time")

**Rise Time (Attack Time)**

This is the ability of a circuit to follow (or "track") a sudden increase in signal level. The shorter the rise time, the better the frequency response. Rise time is usually specified as the interval (in microseconds) required to respond to the leading edge of a square-wave input.

**RMS Level**

RMS level (Root Mean Square) is a measurement obtained by mathematically squaring all the instantaneous voltages along the waveform, adding the squared values together, and taking the square root of that number. For simple sine waves, the RMS value is approximately 0.707 times the peak value, but for complex audio signals, RMS value is more difficult to calculate. RMS level is similar to average level, although not identical (Average level is a slower measurement).

### Sub Harmonic

A sub-multiple of the fundamental frequency. For example, a wave the frequency of which is half the fundamental frequency of another wave is called the second sub harmonic of that wave.

### Sub Woofer

A loudspeaker made specifically to reproduce the lowest of audio frequencies, usually between 20Hz and 100Hz.

### Synthesizer

An ELECTRONIC MUSIC SYNTHESIZER is an audio processor that has a built-in sound generator (oscillator), and that alters the envelope of the sound with voltage controlled circuitry. Synthesizers can produce familiar sounds and serve as musical instruments, or they can create many unique sounds and effects of their own.

A SUB HARMONIC SYNTHESIZER is a device which is not used to create music, but to enhance an existing audio program. In the case of the dbx Model 100, the unit creates a new signal that corresponds to the volume of the input signal, but is at  $1/2$  the frequency of the input signal.

### Tape Saturation

There is a maximum amount of energy that can be recorded on any given type of magnetic tape. When a recorder "tries" to record more energy, the signals become distorted, but are not recorded at any higher levels. This phenomenon is called tape saturation because the magnetic oxide particles of the tape are literally saturated with energy and cannot accept any more magnetization.

**T.H.D. (Total Harmonic Distortion)** (See "Harmonic Distortion")

### Threshold

Threshold is the level at which a compressor or limiter ceases to have linear gain, and begins to perform its gain-changing function (i.e., where the output level no longer rises and falls in direct proportion to the input level). In most systems, the threshold is a point above which the level changes, although there are compressors that raise signal levels below a threshold point. Some compander-type noise reduction systems, such as Dolby,<sup>®</sup> have upper and lower threshold between which the gain changes; these systems require careful level calibration for proper encode/decode performance. dbx noise reduction systems have no threshold at which compression or expansion factors change, so level calibration is not critical.

\*'Dolby' is a trademark of Dolby<sup>®</sup> Laboratories, Inc.

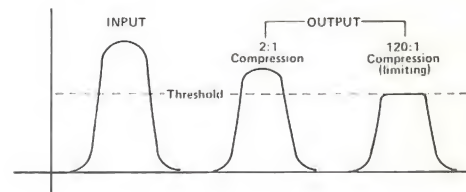

### Tracking Accuracy

Tracking refers to the ability of one circuit to "follow" the changes of another circuit. When two volume controls are adjusted in exactly the same way, the corresponding "sameness" of the output levels can be expressed as the tracking accuracy of the controls.

The level detection circuitry in a dbx encoder senses the signal level, changes the gain, and creates an encoded signal. The corresponding "sameness" of the original signal and the encoded/decoded signal can be expressed as the tracking accuracy of the noise reduction system. (dbx systems are non-critical for the operator, and are built to close tolerances, so that tracking accuracy is excellent, even if the encoder and decoder are in different pieces of dbx equipment.)

### Transition Level (See Level Match)

When a circuit has uniform compression or expansion throughout its full dynamic range, there must be some level which passes through the unit without being raised or lowered (where gain is unity). This unity gain level is the transition level or transition point. The transition point is a "window" 1dB wide, in a dbx encoder (compressor), all signals above the transition point are decreased in level, and all signals below the point are increased in level. Conversely, in a dbx decoder (expander), all signals above the transition point are increased in level, and all signals below the point are decreased in level. The transition level is similar to a "threshold," except it does not refer to a point at which compression or expansion factors change.



## VIII

### **Triamplified**

Similar to biamplified. A sound system where a passive crossover network creates three frequency ranges, and feeds three power amplifiers: one for bass, one for mid, and one for high frequencies. The amplifiers are connected directly to the woofers, midrange drivers and tweeters without a passive, high-level crossover network.

### **Tuner**

A unit which receives radio broadcasts and converts them into audio frequency signals. May be part of a receiver.

### **VCA (Voltage Controlled Amplifier)**

Traditionally, amplifiers have been designed to increase signal levels (to provide gain). If an amplifier were required to decrease the level (to attenuate), it could become unstable, and might even oscillate. The gain (amount of amplification) in these traditional amplifiers would be adjusted by one of three methods (1) attenuating the audio signal fed to the input of the amplifier, (2) attenuating the audio output of the amplifier, or (3) changing the negative feedback (feeding more or less signal from the output back to the input, but in reversed polarity).

The VCA is a special type of amplifier that can be used to increase or decrease levels over a wide dynamic range. Instead of using signal attenuation or negative feedback, the gain (or loss) is adjusted by means of an external dc control voltage. dbx has a unique, patented VCA design that has extremely low noise and very wide dynamic range; the dbx VCA is the heart of dbx noise reduction equipment.

### **Woofers**

A loudspeaker which reproduces only low frequencies.

NOTES

**dbx**<sup>®</sup> inc.

71 Chapel Street  
Newton, MA 02194

Manufactured under one or more of the  
following U.S. patents: 3,681,618;  
3,714,462; 3,789,143; 4,101,849; 4,097,767.  
Other patents pending.

1079.2M-600104

Printed in U.S.A.