

"AUREX"

USER MANUAL

DNR



manufacturer of: recording - broadcast - p.a. - mixingdesks - signal processors

AUREX users manual

The AUREX is a compact and easy to handle device which can be a solution for many situations in sound systems. It restores harmonics, gives clarity without feedback problems and everywhere you switch it on it gives better results.

The AUREX is designed to interface with all available equipment. It has a high input impedance and a low output impedance. Any level is convenient, up to a maximum of + 22 dBu.

The original signal will go through the AUREX without any change in its structure.

Part of the signal is led to the "drive"-control and the "tuning"-circuit while the "mix" adds the harmonics to the original on a very low level.

This is the reason why there is hardly no increase in level when the "mix" is turned clockwise.

Connections are made with standard $\frac{1}{4}$ inch phone-jacks on the back of the unit.

The AUREX channels can be used completely independent from each other.

SETTING UP:

- Connect the input of one or two channels of the AUREX to the line level output of your mixing-console. Any level between -10dBu and + 22 dBu will do. Connect the outputs of your AUREX to the inputs of your power amps or active x-overs.

In this set-up, use stereo jacks only and do not connect the ring to earth at the inputs. (this will increase gain by 20 dB)

Wiring is as shown below: - sleeve to earth

- signal to tip

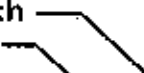

n.c.

- Instruments can be connected directly to the AUREX. If the signal-level is not high enough to drive the enhancing circuit, a mono plug will earth the ring of the input jack and adds another 20 dB gain to the circuit.
- The AUREX can be inserted in the insert jacks of a channel in a mixing-console. Enhancement can be added now to individual channels. This can also be achieved by using aux-sends, sending a part of a signal to the AUREX and have the output of the AUREX coming back into the effect-returns. In this set up the "mix"-control has to be set fully clockwise.



manufacturer of: recording - broadcast - p.a. - mixingdesks - signal processors

- In Sound-reinforcement: You achieve marvellous results using the AUREX in these applications. The sound has more clarity and a greater perceived loudness without feedback problems, especially in your stage monitoring system. Vocals are much clearer now. Discotheques can lower their sound-levels without losing definition because of it's clarity and don't have to boost up the high-end frequency-range which saves also tweeters (and your ears).
- Bad tape copies: These can be avoided by interfacing the AUREX. With very noisy tapes it is best to equalize them first and then to add enhancement to them. A single ended noise reduction system like DNL and Dynafex (tm) will remove most of the noise and of course some harmonics. The AUREX restores these lost harmonics and gives a clean sounding tape as result.
- Reverberation: The AUREX connected to the output of a relatively cheap (spring) reverb will give the sound of a high-priced reverb.
- Paging systems can benefit a lot of enhancement as do theaters, stadions, trainstations and airports. It gives more clarity and vocal articulation is much cleaner.

I hope that you are able now to use all the potentials of the AUREX and that we have another satisfied customer.

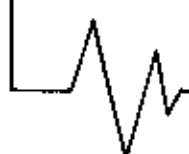



manufacturer of: recording - broadcast - p.a. - mixingdesks - signal processors

- To use the AUREX at home in your Hi-Fi system it is best interfaced in the outputwires from your cassette-deck (if you have one) to the (pre-) amp. By activating your tape return (on your (pre-) amp) and by setting your cassette-player in the "record"-mode you can have the benefit of the AUREX on all kinds of signal sources such as compact-disc, grammophone, radio-broadcasting.

If you do not have a cassette-player then see your AUREX as a cassette-player and wire it up as you should do as it was a cassette-player.

By activating your "tape"-button on your Hi-Fi -(pre-) amp you will be rewarded with an unbelievable clarity.

If you have a separate pre-amp and a power-amp, the best way is to connect the AUREX between these two.

SETTING UP THE CONTROLES:

Turn the "drive" and "mix" controles fully counter clockwise and the "tune" control on 12 o'clock. Leave the on/off switch to it's up/off-position.

Now slowly turn the "drive"-control clockwise until the green (in the middle) LED lits regularly and the red LED occasionally.

If you can't achieve lighting the LED's then connect the ring of the input jack to earth. (this will give you an extra 20 dB gain)

Now turn on the on/off switch and slowly turn the "mix"-control c.w. until you hear that exciting AUREX enhancement.

In the beginning it is normal that you are overdoing this because you want to hear it.

Proper use of the AUREX is to set it in a way you're not hearing it, but missing it when it is switched off.

Carefully compare several times the enriched sound with the original, mostly dull, sound.

If you use the AUREX well (not in a way you need a de-esser, which we have too) you will soon notice that you can't do without it anymore.

The "tune" control selects the part of music/speech that you want to enhance.

Note:

The "tune"-control interacts with the "drive"-control, so please notice the green and red LED's, and adjust, when necessary.

SUGGESTIONS:

- In studio set-up: Using the AUREX on recording instead of in the mastermix will give you an improvement in your signal to noise ratio.

Note: use the AUREX in this situation always ahead of your noise-reduction system.

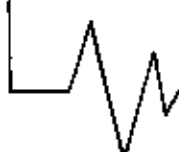

Conformity statement according to ISO/IEC Nr. 22 and EN 45014

Name Manufacturer D&R Electronica Weesp b.v.
Address manufacturer Rijnkade 15B,
1382 GS Weesp,
The Netherlands

declares that this product

Name product Aurex Exciter
Modelnumber n.a.
Produktioptions All

passed the following product specifications:

Security EN 60950: 1988 +A1, A2

EMC: CISPR-22: 1985 / EN 55022: 1988 class B (*)
EN 50082-1: 1992
IEC 801-2:1991 / prEN 55024-2:1992 - 3kV CD, 8kV AD
IEC 801-3:1984 / prEN 55024-3:1991 - 3 V/m
IEC 801-4:1988 / prEN 55024-4:1992 - 0.5kV signalcables,
1 kV powercables.

Extra information:

The product passed the specifications of the following regulations;

Low voltage 73 / 23 / EEG
EMC-regulations 89 / 336 / EEG.

(*) The product is tested in a normal users environment.



"AUREX"

SERVICE MANUAL

DNR

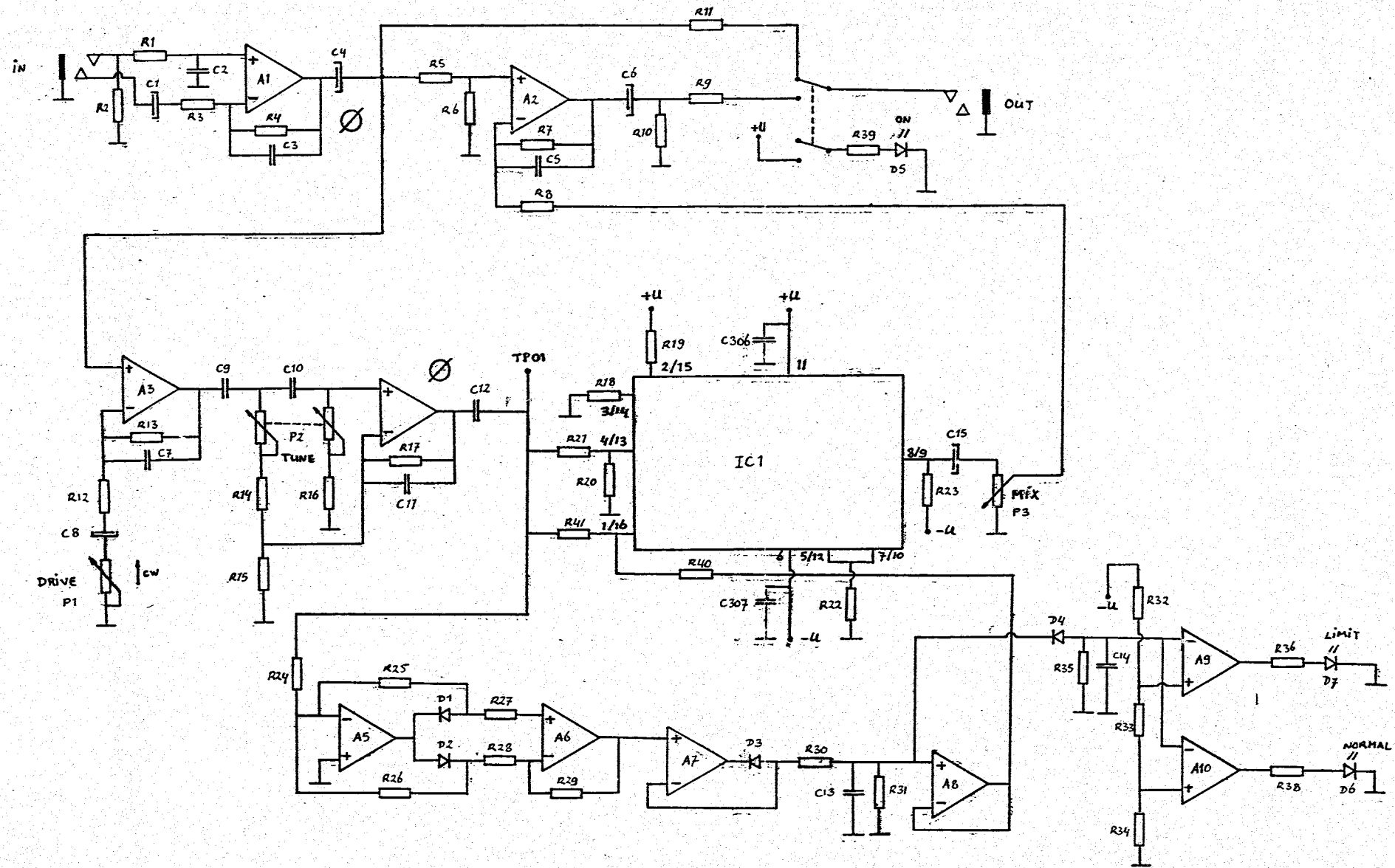

=====

== ELECTRONICA B.V. ==

produktie en ontwikkeling van
geluidsmengpanelen en accessoires

Date: 12-03-1986

R & D department

Title : Partlist Aurex 1a

PartNr	Value	Notes	ArtNr
R1	1 k	5%	0729
R2	100 k	5%	0753
R3	1 k	5%	0729
R4	10 k	5%	0741
R5	10 k	5%	0741
R6	27 k	5%	0746
R7	10 k	5%	0741
R8	27 k	5%	0746
R9	100 E	5%	0717
R10	47 k	5%	0749
R11	100 E	5%	0717
R12	220 E	5%	0721
R13	47 k	5%	0749
R14	15 k	5%	0743
R15	1 k	5%	0729
R16	15 k	5%	0743
R17	2 k 2	5%	0733
R18	470 E	5%	0725
R19	15 k	5%	0743
R20	470 E	5%	0725
R21	10 k	5%	0741
R22	47 k	5%	0749
R23	2 k 7	5%	0734
R24	4 k 75	1%	0844
R25	4 k 75	1%	0844
R26	4 k 75	1%	0844
R27	4 k 75	1%	0844
R28	4 k 75	1%	0844
R29	4 k 75	1%	0844
R30	1 k	5%	0729
R31	470 k	5%	0761
R32	75 k 0	1%	0870
R33	10 k	5%	0744
R34	10 k	5%	0741
R35	470 k	5%	0761
R36	1 k 5	5%	0731
R37	n.v.t.		
R38	1 k 5	5%	0731
R39	1 k 5	5%	0731
R40	47 k	5%	0749
R41	150 k	5%	0755
C1	47/25	elco	0287
C2	270 p	ker	0230
C3	33 p	ker	0219
C4	47/25	elco	0287
C5	100 p	ker	0225

C6	47/25	elco	0287
C7	4 p 7	ker	0209
C8	47/25	elco	0287
C9	2200 p	poly	0248
C10	2200 p	poly	0248
C11	47 p	ker	0221
C12	0.1 u	poly	0261
C13	0.1 u	poly	0261
C14	1/63	elco	0279
C15	47/25	elco	0287
C300	470/40	elco	0295
C301	470/40	elco	0295
C302	47/25	elco	0287
C303	47/25	elco	0287
C304	0.1/63	ker	0241
C305	0.1/63	ker	0241
C306	0.1/63	ker	0241
C307	0.1/63	ker	0241
C308	0.1/63	ker	0241
D1	1N4148	sgn	0342
D2	1N4148	sgn	0342
D3	1N4148	sgn	0342
D4	1N4148	sgn	0342
D5	LED GRN	5*2	0389
D6	LED GRN	5*2	0389
D7	LED RED	5*2	0390
B300	B80C1000		0345
IC1	LM13700 N	OTA	0274
A1,2	NE 5532	lownoise	0307
A3-6	TL 074	bifet	0305
A7-10	TL 074	bifet	0305
IC300	7918	pos.reg.	0322
IC301	7918	neg.reg.	0323
P1	100 k C	12.5mm	0629
P2	100 k Cst	12.5mm	0891
P3	10 k B	12.5	0884
TR300	220-110/2*18V	3VA	0582
TR301	220-110/2*18V	3VA	0582
FS300	Zek.houd.isol.pr.	+Zek.160mA	0675/0693
J1	Cliff break	plastic	0432
J2	Cliff break	plastic	0432
S1	Fox 2xom	MBB	0403
S300	Schak.115/230V		0883