

REVISIONS			
REV.	DESCRIPTION	DATE	APPROVED
A	EC 2333	04-AUG-99	MCU

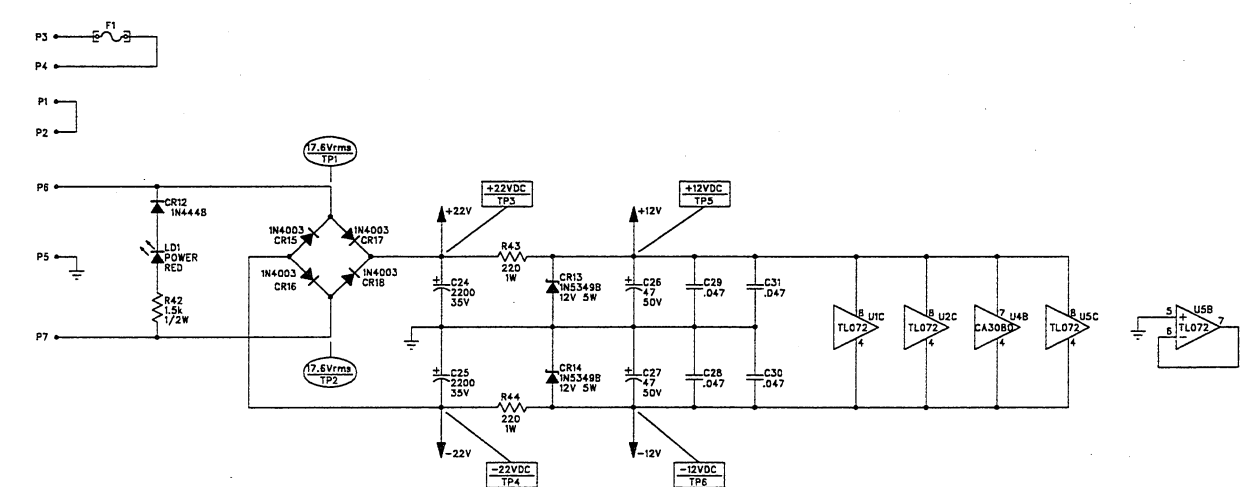
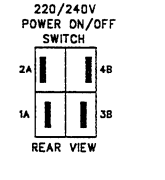
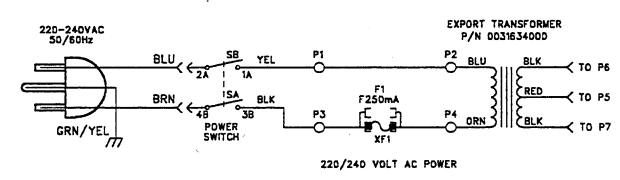
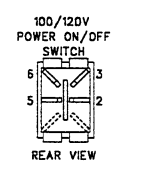
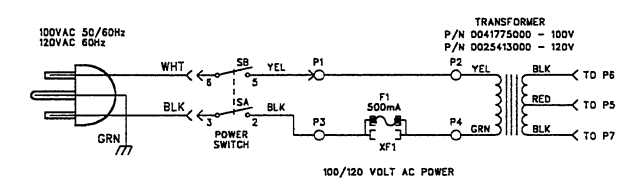
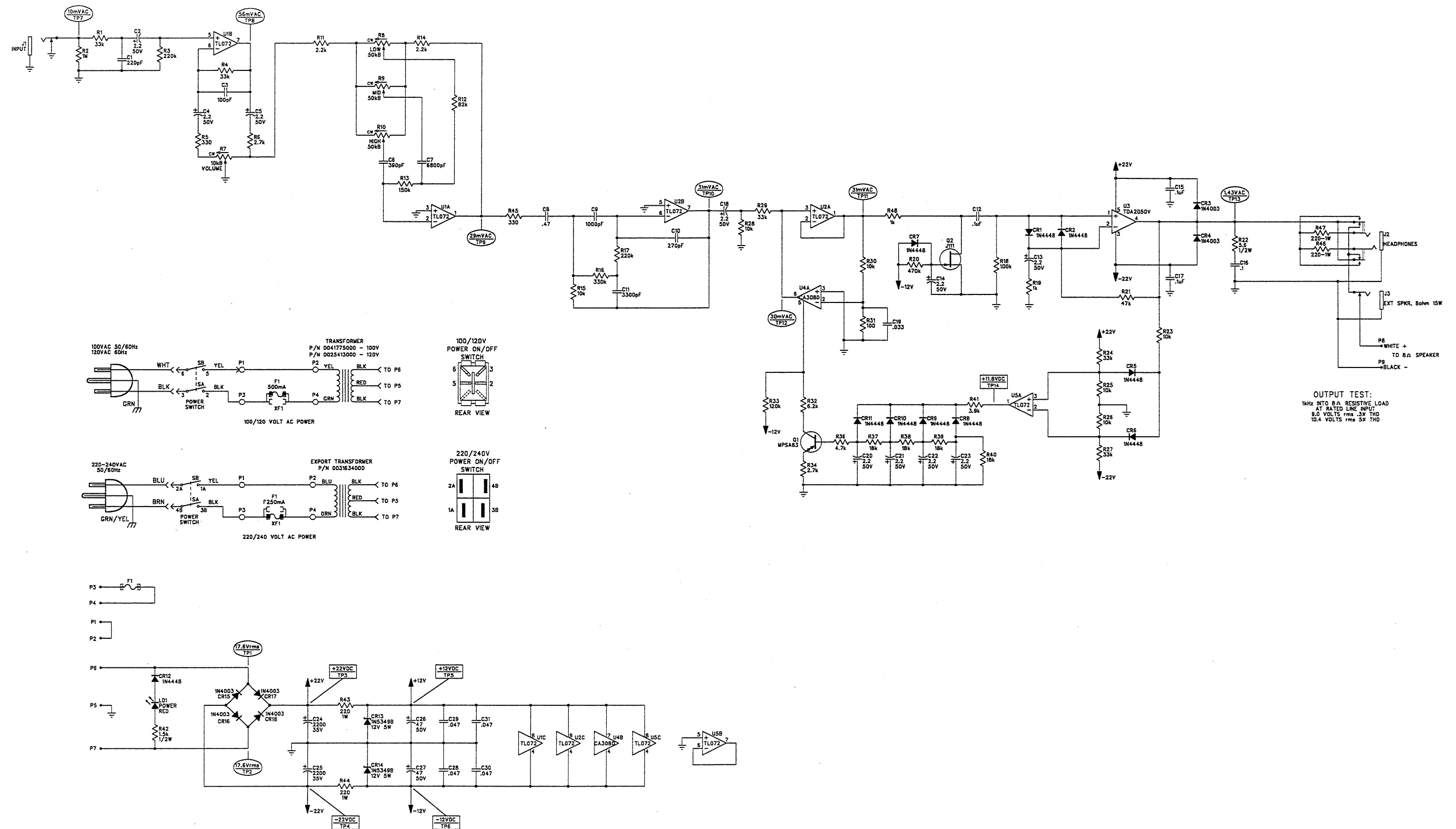

- 6. LAST REFERENCE DESIGNATORS: C31, CR18, F1, J3, PS, Q2, R48, TP14, US, W11.
- 5. ALL VOLTAGES MAY VARY +/-20%.
- 4. AC VOLTAGE READINGS TAKEN WITH A DVM TO GROUND UNDER THE FOLLOWING CONDITIONS:
1kHz INPUT APPLIED THROUGH 1/4" PLUG TO J1
8.0 RESISTIVE LOAD CONNECTED AT P8, P9
ALL CONTROLS SET TO 12 O'CLOCK
- 3. DC VOLTAGES READ TO GROUND WITH A DVM, NO INPUT SIGNAL.
- 2. ALL CAPACITORS IN uF; 50V MINIMUM.
- 1. ALL RESISTORS IN OHMS; 1/4W, 5%.

THIS DOCUMENT CONTAINS INFORMATION OF A PROPRIETARY NATURE TO FENDER MUSICAL INSTRUMENTS AND IS SUBMITTED TO YOU IN CONFIDENCE AND SHALL NOT BE DISCLOSED OR TRANSMITTED TO OTHERS WITHOUT AUTHORIZATION FROM FENDER MUSICAL INSTRUMENTS.

Fender MUSICAL INSTRUMENTS
2621 Research Drive
Corona, CA 91720 USA

CHECKED BY: *[Signature]*
DATE: 25-AUG-99

APPROVED BY: MULRICH
DATE: 21-SEP-99

DRAWN: MULRICH ENGR:SAMS/ULRICH
DATABASE FILE: Z359S.SCH

TITLE: SERVICE DIAGRAM, COMBINED (schematic)
FRONTMAN 15B BASS AMPLIFIER

SIZE: D
DRAWING NUMBER: 0054408000
REV: A

RELEASE DATE: 04-AUG-99 SHEET: 1 OF 2

8 7 6 5 4 3 2 1

REVISIONS			
REV.	DESCRIPTION	DATE	APPROVED
A	EC 2333	04-AUG-99	MCU

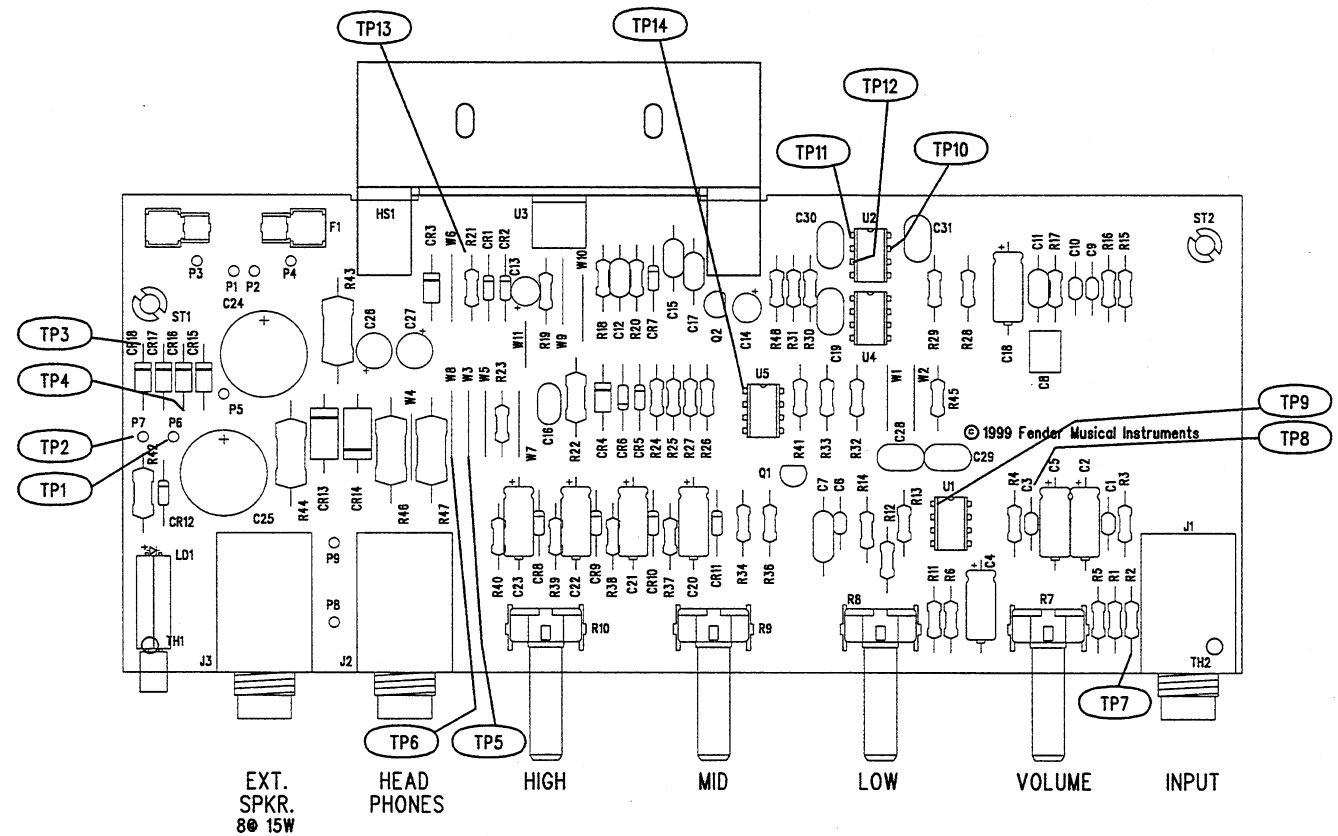

FILM/DWG: SERVICE DIAGRAM
 DATABASE: Z359P.PCB DATE: 04-AUG-99

1. SEE SHEET 1 FOR PRIMARY WIRING, TEST CONDITIONS AND TEST POINT VALUES.
 NOTES: (UNLESS OTHERWISE NOTED)

THIS DOCUMENT CONTAINS INFORMATION OF A PROPRIETARY NATURE TO FENDER MUSICAL INSTRUMENTS AND IS SUBMITTED TO YOU IN CONFIDENCE AND SHALL NOT BE DISCLOSED OR TRANSMITTED TO OTHERS WITHOUT AUTHORIZATION FROM FENDER MUSICAL INSTRUMENTS.		 MUSICAL INSTRUMENTS 2621 Research Drive Corona, CA 91720 USA	
CHECKED BY: <u>Paloni</u>	DATE: <u>29-AUG-99</u>	TITLE: SERVICE DIAGRAM, COMBINED (PCB assy) FRONTMAN 15B BASS AMPLIFIER	
APPROVED BY: <u>MULRICH</u>	DATE: <u>21-SEP-99</u>	SIZE: C	DRAWING NUMBER: 0054408000
DRAWN: MULRICH	ENGR: SAMS/MULRICH	REV: A	
DATABASE FILE: Z359P.PCB	RELEASE DATE: 04-AUG-99	SHEET 2 OF 2	

8 7 6 5 4 3 2 1