

TFM-9450W

USA Model
Canada Model



FM/AM TABLE RADIO

SPECIFICATIONS

Circuit:	11-transistor, 10-diode 2-band superheterodyne	Power Output:	5W maximum
Frequency Ranges:	FM 87.5 ~ 108 MHz (3.42 ~ 2.78m) AM 530 ~ 1,605 kHz (566 ~ 187 m)	Speaker:	16 cm (6 $\frac{1}{2}$ ") dia PM dynamic, 8 Ω
Intermediate Frequencies:	FM 10.7 MHz AM 455 kHz	Power Requirements:	120 VAC 60Hz, 15W
Antennas:	FM ac line antenna, ext ant terminals provided AM built-in ferrite bar antenna	Dimensions:	365 (w) x 220 (h) x 150 (d) mm 14 $\frac{3}{8}$ (w) x 8 $\frac{5}{8}$ (h) x 5 $\frac{7}{8}$ (d) inches
Sensitivity		Weight:	3.35 kg, 7 lb 6 oz
at 50 mW output:	FM 4.4 μ V (13 dB), S/N = 30 dB AM 89 μ V/m (39 dB/m) maximum		
Selectivity:	33 dB at \pm 10 kHz off-resonance at 1,000 kHz		

SONY[®]
SERVICE MANUAL

TABLE OF CONTENTS

<u>Section</u>	<u>Title</u>	<u>Page</u>
	Specifications	1
	Hardware Nomenclature	2
SECTION 1. OUTLINE		
1-1.	Block Diagram	3
1-2.	External View	3
1-3.	Internal View	4
SECTION 2. DISASSEMBLY		
2-1.	Rear Cover Removal	5
2-2.	Chassis Removal	5
2-3.	Dial Scale Removal	5
2-4.	BAND and LOUDNESS Switches' Bracket Removal	6
2-5.	Dial Cord Stringing	6
SECTION 3. CIRCUIT ADJUSTMENTS		
3-1.	Test Equipment/Tools Required	7
3-2.	FM I-f Alignment	7
3-3.	FM Frequency Coverage Adjustment	7
3-4.	FM Tracking Adjustment	7
3-5.	AM I-f Alignment	8
3-6.	AM Frequency Coverage Adjustment	8
3-7.	AM Tracking Adjustment	8
SECTION 4. SCHEMATIC AND MOUNTING DIAGRAMS		
4-1.	Schematic Diagram	9
4-2.	Mounting Diagram – Conductor Side –	11
SECTION 5. EXPLODED VIEW AND PACKING		
5-1.	Exploded View	13
5-2.	Packing	15
SECTION 6. ELECTRICAL PARTS LIST		
		16

— Hardware Nomenclature —

<p>P – Pan Head Screw </p> <p>PS – Pan Head Screw with Spring Washer </p> <p>K – Flat Countersunk Head Screw </p> <p>B – Binding Head Screw </p> <p>RK – Oval Countersunk Head Screw </p> <p>T – Truss Head Screw </p> <p>R – Round Head Screw </p> <p>F – Flat Fillister Head Screw </p>	<p>SC – Set Screw </p> <p>E – Retaining Ring (E Washer) </p> <p style="text-align: center;">W – Washer SW – Spring Washer LW – Lock Washer N – Nut</p> <p>— Example —</p> <div style="display: flex; align-items: center;"> <div style="margin-right: 20px;"> <p>⊕ P 3x10</p> <p>└── Type of Slot</p> <p>└── Length in mm (L)</p> <p>└── Diameter in mm (D)</p> <p>└── Type of Head</p> </div> </div>
---------------------------------------------------------------------------------------------------------------------------------------------------------------------------------------------------------------------------------------------------------------------------------------------------------------------------------------------------	---------------------------------------------------------------------------------------------------------------------------------------------------------------------------------------------------------------------------------------------------------------------------------------------------------------------------------------------------------------------------------------------------------------------------------

When ordering replacement parts, use PART NUMBERS listed in Parts List or shown in EXPLODED VIEW. Parts List reference numbers should not be used.

Note: All screws in the set are Phillips type (cross recess type) unless otherwise indicated.
(-): slotted head

TFM-9450W TFM-9450W

SECTION 1 OUTLINE

1-1. BLOCK DIAGRAM

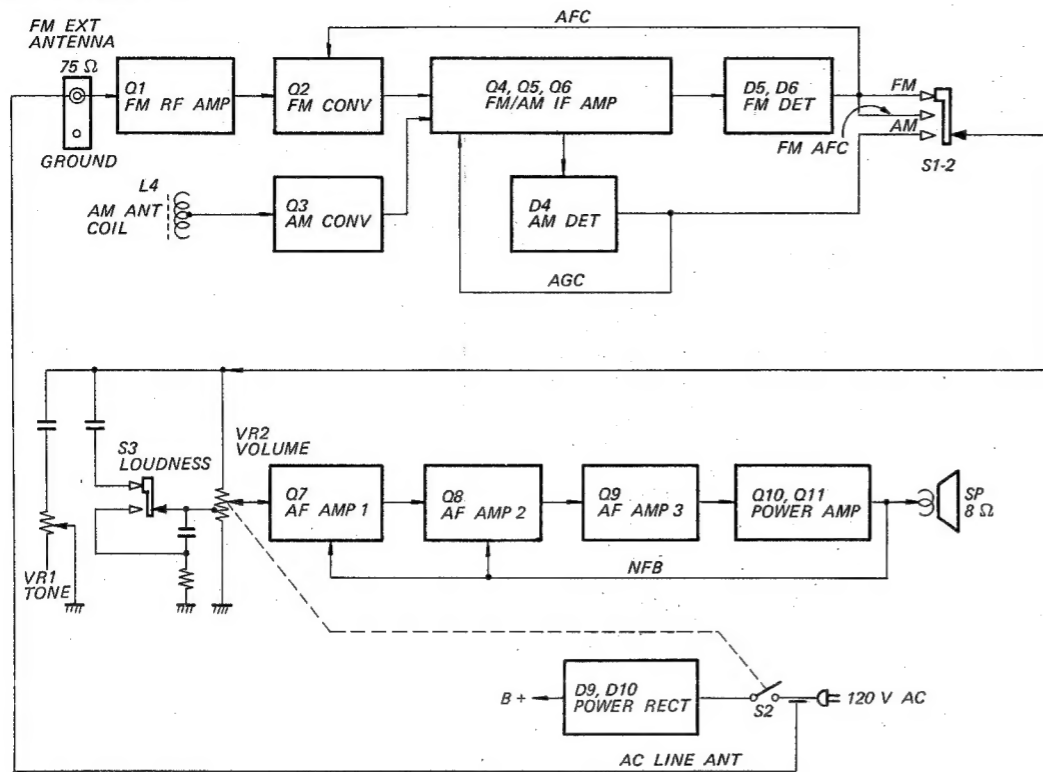

Fig. 1-1.

1-2. EXTERNAL VIEW

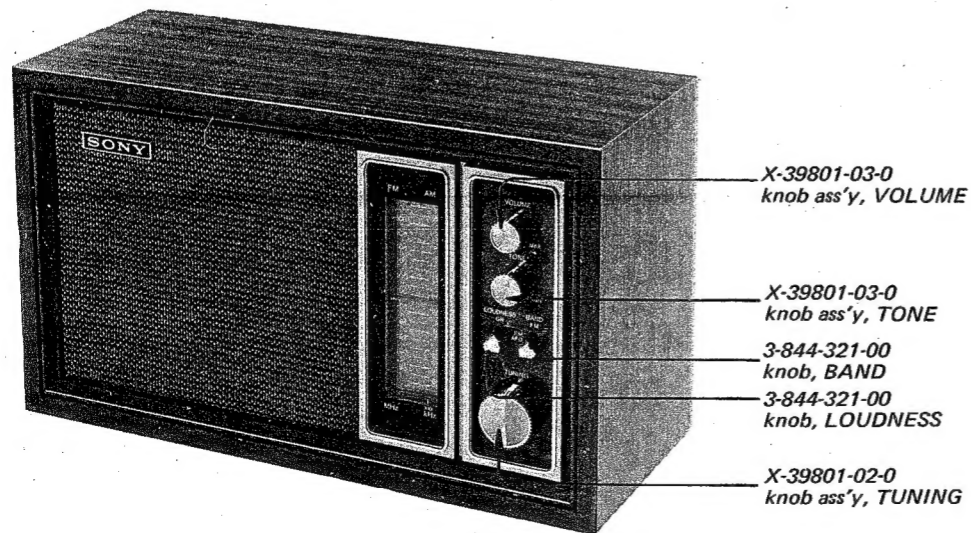

Fig. 1-2.

1-3. INTERNAL VIEW

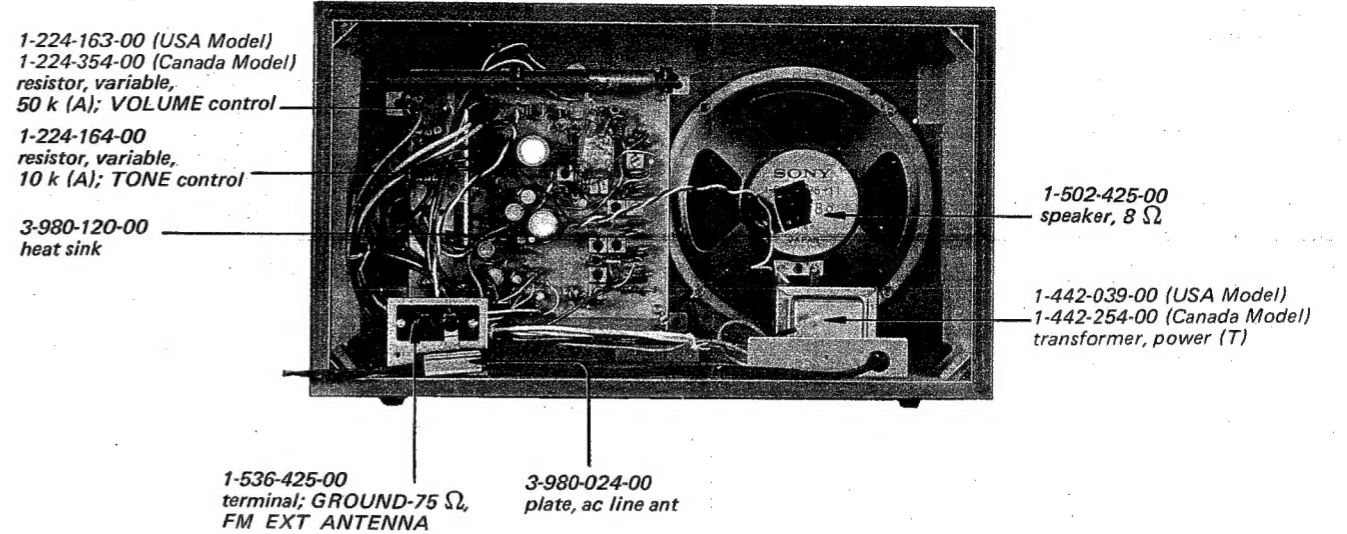

Fig. 1-3.

SECTION 2
DISASSEMBLY

2-1. REAR COVER REMOVAL

Remove rear cover in the numerical order shown in Fig. 2-1 below.

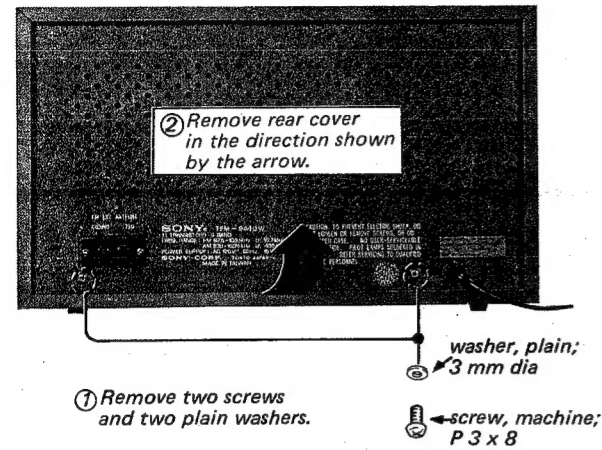

Fig. 2-1.

2-2. CHASSIS REMOVAL

Remove chassis in the numerical order shown below.

- ① Remove rear cover as shown in Fig. 2-1 above.
- ② Pull off VOLUME, TONE and TUNING knob assemblies, BAND and LOUDNESS knobs shown in Fig. 2-2 below.

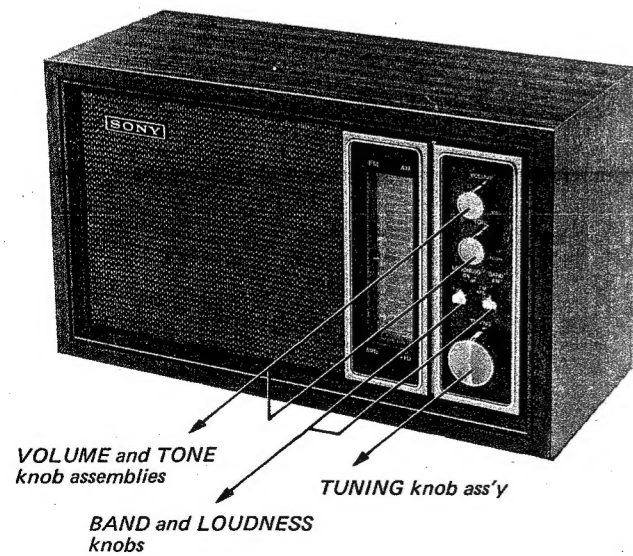

Fig. 2-2.

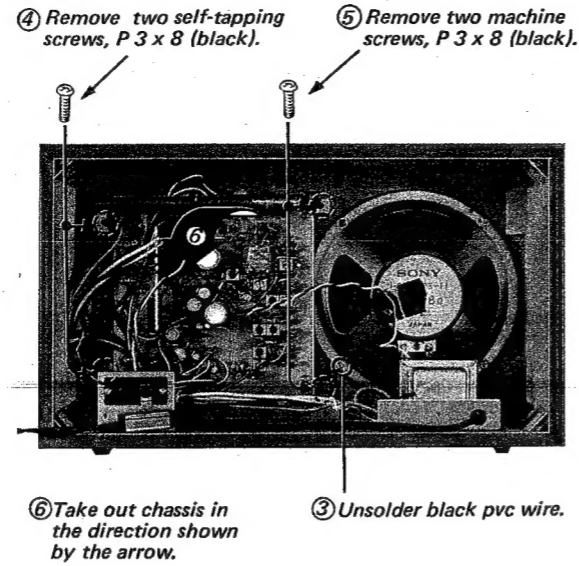

Fig. 2-3.

2-3. DIAL SCALE REMOVAL

Remove dial scale in the numerical order shown below.

- ① Remove chassis as shown in 2-2 above.

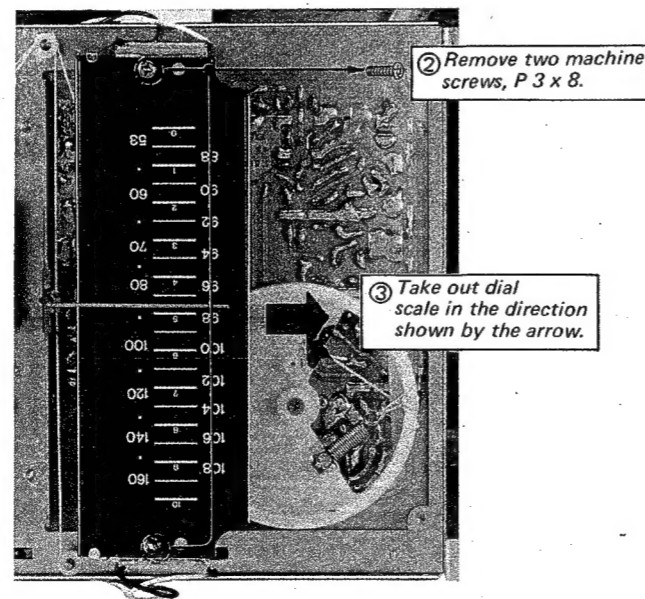

Fig. 2-4.

Note: Voltage checking and parts replacement can be performed without removing circuit board.

2-4. BAND AND LOUDNESS SWITCHES' BRACKET REMOVAL

Remove BAND and LOUDNESS switches' bracket in the numerical order shown below.

- ① Remove chassis as outlined in 2-2 above.

- ② Remove machine screw, P 3 x 6.

- ③ Remove BAND and LOUDNESS switches' bracket in the direction shown by the arrow.

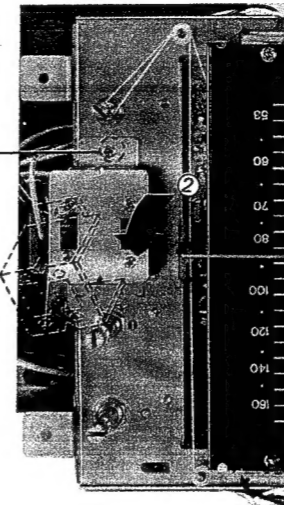

Fig. 2-5.

2-5. DIAL CORD STRINGING

1. Make a dial cord assembly shown in Fig. 2-6 below.

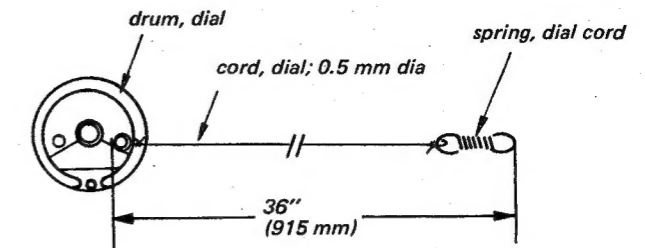

Fig. 2-6.

2. String the dial cord in the numerical order shown in Fig. 2-7 below.

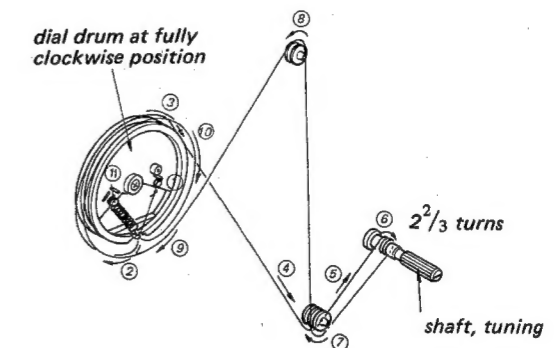

Fig. 2-7.

3. Set the tuning shaft to fully counterclockwise position.

4. Set the dial pointer ass'y on the dial cord so that the dial pointer places on the mark "0" of the logging scale, and fix the dial pointer ass'y on the dial cord with a small amount of lock paint as shown in Fig. 2-8 below.

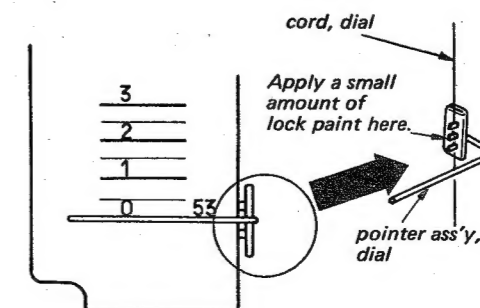

Fig. 2-8.

SECTION 3
CIRCUIT ADJUSTMENTS

3-1. TEST EQUIPMENT/TOOLS REQUIRED

- * AM rf signal generator
- * FM rf signal generator
- * Loop antenna
- * VOM
- * Alignment screwdriver

Preparation:

- AM rf signal generator modulation: 1 kHz, 30 %
- AM rf signal generator output level: Usable lowest possible.
- FM rf signal generator modulation: 400 Hz, ± 22.5 kHz deviation
- FM rf signal generator output level: Usable lowest possible
- FM rf signal generator coupling: Direct connection to FM EXT ANTENNA terminals.
- VOLUME control setting: MAX
- TO NE control setting: HIGH
- LOUDNESS switch setting: OFF

3-2. FM I-F ALIGNMENT

Test Setup:

Fig. 3-1. Fig. 3-2.

Step	Rf Signal Generator Frequency	Receiver Dial Setting	Adjust	Remarks
1	10.7 MHz with FM modulation	No station, no beating position	Cores of IFT F-1 IFT F-2 IFT F-3 IFT F-4 IFT F-5	Test setup: See Fig. 3-1. BAND selector: FM Adjust for maximum meter reading. Repeat adjustment two or three times.
2	No input Signal (noise only)	- ditto -	Core of IFT F-5	Test setup: See Fig. 3-2. Adjust for "0 V DC" meter reading.

3-3. FM FREQUENCY COVERAGE ADJUSTMENT

Test Setup: Same as Fig. 3-1.

Rf Signal Generator Coupling	Rf Signal Generator Frequency	Receiver Dial Setting	Adjust	Remarks
Direct connection to FM EXT ANTENNA terminals	86.5 MHz	Minimum frequency	Pitch of FM osc coil L3	BAND selector: FM Adjust for maximum meter reading. Repeat adjustment two or three times ending with TC2. Fix L3 with wax.
	110 MHz	Maximum frequency	FM osc trimmer TC2	

3-4. FM TRACKING ADJUSTMENT

Test Setup: Same as Fig. 3-1.

Rf Signal Generator Coupling	Rf Signal Generator Frequency	Receiver Dial Setting	Adjust	Remarks
Direct connection to FM EXT ANTENNA terminals	86.5 MHz	Minimum frequency	Pitch of FM rf coil L2	BAND selector: FM Adjust for maximum meter reading. Repeat adjustment two or three times ending with TC1. Fix L2 with wax.
	110 MHz	Maximum frequency	FM rf trimmer TC1	

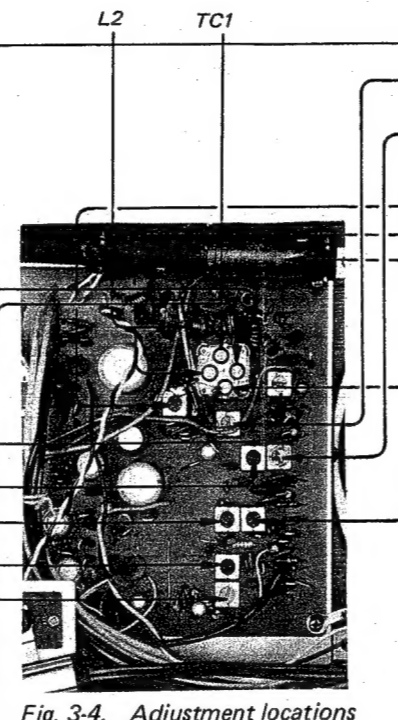

3-5. AM I-F ALIGNMENT

Test Setup:

Fig. 3-3.

Rf Signal Generator Coupling	Rf Signal Generator Frequency	Receiver Dial Setting	Adjust	Remarks
Loop antenna See Fig. 3-3.	455 kHz	No station, no beating position	Cores of IFT A-1 IFT A-2 IFT A-3	BAND selector: AM Adjust for maximum meter reading. Repeat adjustment two or three times.

3-6. AM FREQUENCY COVERAGE ADJUSTMENT

Test Setup:

Fig. 3-4.

Rf Signal Generator Coupling	Rf Signal Generator Frequency	Receiver Dial Setting	Adjust	Remarks
Loop antenna See Fig. 3-4.	520 kHz	Minimum frequency	Core of AM osc coil L6	BAND selector: AM Adjust for maximum meter reading. Repeat adjustment two or three times ending with TC4.
	1,680 kHz	Maximum frequency	AM osc trimmer TC4	

3-7. AM TRACKING ADJUSTMENT

Test Setup:

Fig. 3-5.

Rf Signal Generator Coupling	Rf Signal Generator Frequency	Receiver Dial Setting	Adjust	Remarks
Loop antenna See Fig. 3-5.	620 kHz	Tune in 620 kHz signal	Position of AM ant coil L4	BAND selector: AM Adjust for maximum meter reading. Repeat adjustment two or three times ending with TC3. Fix L4 with wax.
	1,400 kHz	Tune in 1,400 kHz signal	AM ant trimmer TC3	

TFM-9450W TFM-9450W

SECTION 4 SCHEMATIC AND MOUNTING DIAGRAMS

4-1. SCHEMATIC DIAGRAM

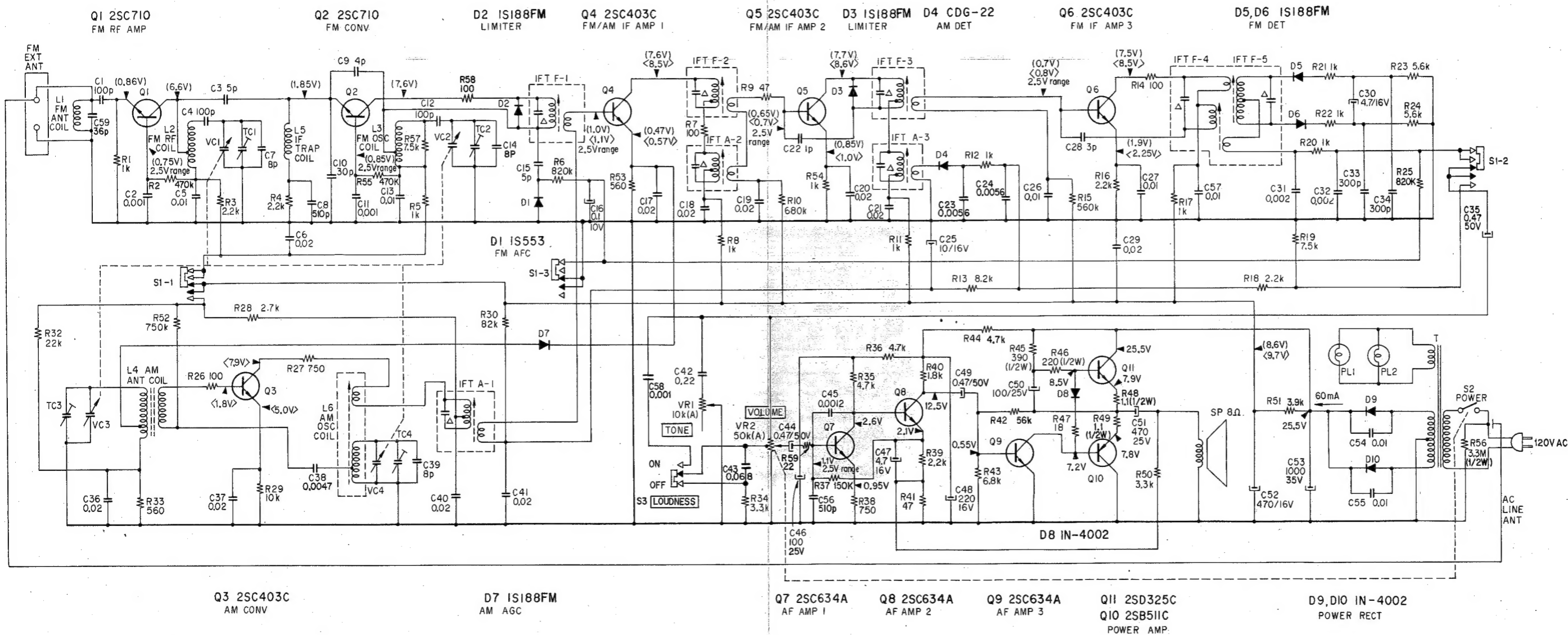

Note:

1. All fixed resistors are in Ω , $\pm 5\%$, $\frac{1}{4}$ W.
2. All fixed capacitors are in μ F unless otherwise specified.
3. Voltage readings are taken with a 20 $k\Omega/V$ DC VOM with reference to heavy lines. Those shown in () indicate readings on FM, in < > on AM, others are common.
4. Capacitors marked with Δ are built in i-f transformers.

Fig. 4-1.

TFM-9450W TFM-9450W

4-2. MOUNTING DIAGRAM — Conductor Side —

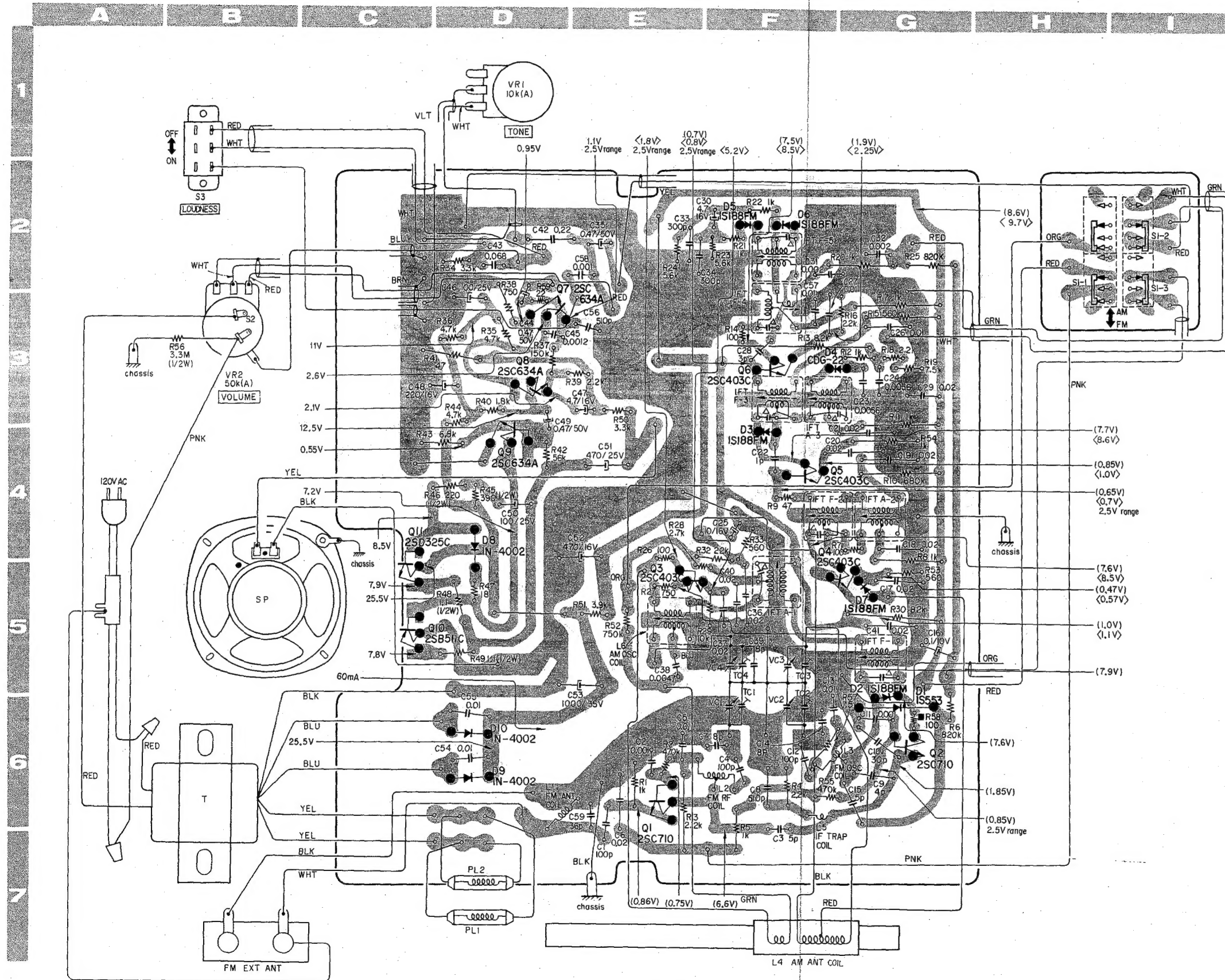

Transistor Location

Q1:	6E	Q7:	3D
Q2:	6G	Q8:	3D
Q3:	5E	Q9:	3D
Q4:	5G	Q10:	5C
Q5:	4F	Q11:	4C
Q6:	3F		

Q1, Q2: 2SC710

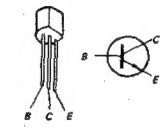

D1: 1S553

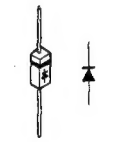

Q3-Q6: 2SC403C
Q7-Q9: 2SC634A

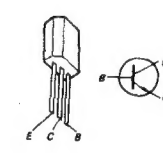

D2-D7: 1S188

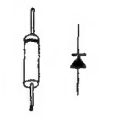

Q10: 2SB511C

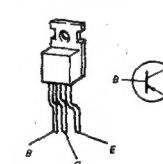

D8-D10: 1N-4002

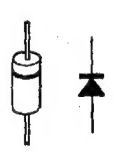

Q11: 2SD325C

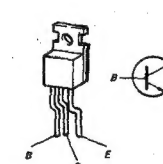

Note: R58 marked with ■ is mounted on the conductor side.

Fig. 4-2.

5-2. PACKING

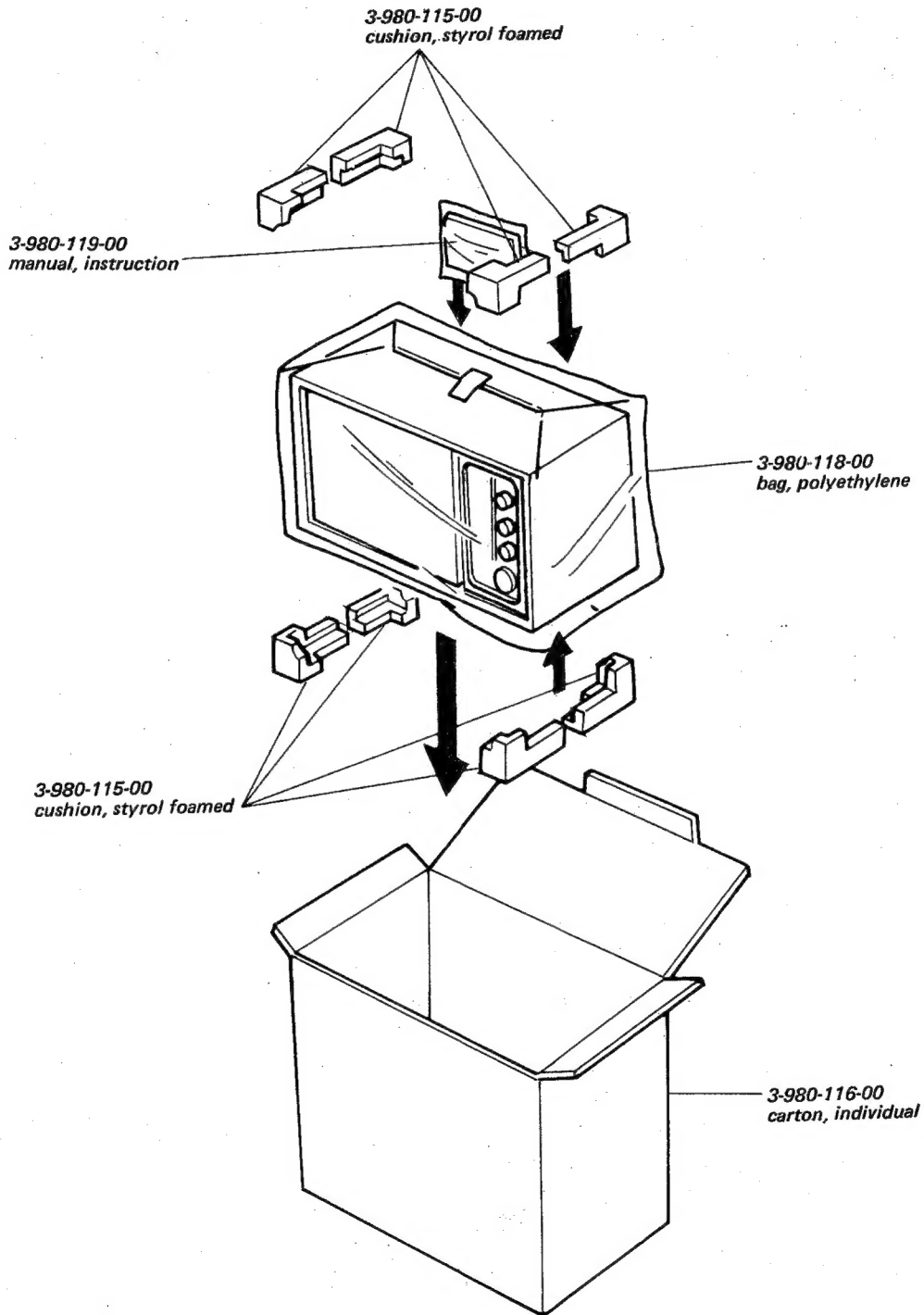

Note:

- Items without part number and description are not available.

Fig. 5-2.

**SECTION 6
ELECTRICAL PARTS LIST**

<u>Ref. No.</u>	<u>Part No.</u>	<u>Description</u>	<u>Ref. No.</u>	<u>Part No.</u>	<u>Description</u>
COMPLETE CIRCUIT BOARD			C1	1-101-963-11	100 p
8-981-210-90		complete circuit board	C2	1-101-918-11	0.001
SEMICONDUCTORS			C3	1-101-955-11	5 p
Q1		transistor 2SC710	C4	1-101-963-11	100 p
Q2		transistor 2SC710	C5	1-101-923-11	0.01
Q3		transistor 2SC403C	C6	1-101-924-11	0.02
Q4		transistor 2SC403C	C7	1-101-958-11	8 p
Q5		transistor 2SC403C	C8	1-101-421-11	510 p
Q6		transistor 2SC403C	C9	1-101-954-11	4 p
Q7		transistor 2SC634A	C10	1-101-900-11	30 p
Q8		transistor 2SC634A	C11	1-101-918-11	0.001
Q9		transistor 2SC634A	C12	1-101-963-11	100 p
Q10		transistor 2SB511C	C13	1-101-923-11	0.01
Q11		transistor 2SD325C	C14	1-101-958-11	8 p
D1		diode 1S553	C15	1-101-955-11	5 p
D2		diode 1S188FM	C16	1-127-019-11	0.1 10 V solid aluminum
D3		diode 1S188FM	C17	1-101-924-11	0.02
D4		diode CDG-22	C18	1-101-924-11	0.02
D5		diode 1S188FM	C19	1-101-924-11	0.02
D6		diode 1S188FM	C20	1-101-924-11	0.02
D7		diode 1S188FM	C21	1-101-924-11	0.02
D8		diode 1N-4002	C22	1-101-951-11	1 pF
D9		diode 1N-4002	C23	1-105-670-12	0.0056 mylar
D10		diode 1N-4002	C24	1-105-670-12	0.0056 mylar
COILS AND TRANSFORMERS			C25	1-121-471-11	10 16 V electrolytic
IFT A-1	1-403-876-00	transformer, AM i-f	C26	1-101-923-11	0.01
IFT A-2	1-403-875-00	transformer, AM i-f	C27	1-101-923-11	0.01
IFT A-3	1-403-874-00	transformer, AM i-f	C28	1-101-953-11	3 p
IFT F-1	1-403-887-00	transformer, FM i-f	C29	1-101-924-11	0.02
IFT F-2	1-403-886-00	transformer, FM i-f	C30	1-121-394-11	4.7 16 V electrolytic
IFT F-3	1-403-886-00	transformer, FM i-f	C31	1-101-919-11	0.002
IFT F-4	1-403-885-00	transformer, FM i-f	C32	1-101-919-11	0.002
IFT F-5	1-403-884-00	transformer, FM i-f	C33	1-101-398-11	300 p
L1	1-405-530-00	coil, FM ant	C34	1-101-398-11	300 p
L2	1-405-590-00	coil, FM rf	C35	1-121-726-11	0.47 50 V electrolytic
L3	1-405-592-00	coil, FM osc	C36	1-101-924-11	0.02
L4	1-401-535-00	coil, AM ferrite bar ant	C37	1-101-924-11	0.02
L5	1-405-544-00	coil, i-f trap	C38	1-105-829-12	0.0047 mylar
L6	1-405-529-00	coil, AM osc	C39	1-101-958-11	8 p
T	1-442-039-00	transformer, power (USA Model)	C40	1-101-924-11	0.02
	1-442-254-00	transformer, power (Canada Model)	C41	1-101-924-11	0.02
CAPACITORS			C42	1-105-849-12	0.22 mylar
All fixed capacitors are in μ F and ceramic type unless otherwise specified. p = μ u.			C43	1-105-843-12	0.068 mylar
			C44	1-121-726-11	0.47 50 V electrolytic
			C45	1-105-662-12	0.0012 mylar
			C46	1-121-377-11	100 25 V electrolytic
			C47	1-121-394-11	4.7 16 V electrolytic
			C48	1-121-421-11	220 16 V electrolytic
			C49	1-121-726-11	0.47 50 V electrolytic
			C50	1-121-377-11	100 25 V electrolytic
			C51	1-121-733-11	470 25 V electrolytic
			C52	1-121-426-11	470 16 V electrolytic
			C53	1-121-388-11	1,000 35 V electrolytic

<u>Ref. No.</u>	<u>Part No.</u>	<u>Description</u>
C54	1-102-317-11	0.01
C55	1-102-317-11	0.01
C56	1-101-421-11	510 p
C57	1-101-923-11	0.01
C58	1-105-821-12	0.001 mylar
C59	1-101-875-11	36 p

TC1-TC4 VC1-VC4	1-151-261-00	tuning
--------------------	--------------	--------

RESISTORS

All fixed resistors are in Ω , $\pm 5\%$, $\frac{1}{4}$ W carbon film type.
k = 1,000, M = 1,000,000.

R1	1-242-673-11	1 k
R2	1-242-737-11	470 k
R3	1-244-681-11	2.2 k
R4	1-242-681-11	2.2 k
R5	1-242-673-11	1 k
R6	1-242-743-11	820 k
R7	1-242-649-11	100
R8	1-244-673-11	1 k
R9	1-242-641-11	47
R10	1-244-741-11	680 k
R11	1-244-673-11	1 k
R12	1-242-673-11	1 k
R13	1-244-695-11	8.2 k
R14	1-242-649-11	100
R15	1-244-739-11	560 k
R16	1-242-681-11	2.2 k
R17	1-244-673-11	1 k
R18	1-242-681-11	2.2 k
R19	1-242-694-11	7.5 k
R20	1-244-673-11	1 k
R21	1-242-673-11	1 k
R22	1-242-673-11	1 k
R23	1-242-691-11	5.6 k
R24	1-242-691-11	5.6 k
R25	1-242-743-11	820 k
R26	1-242-649-11	100
R27	1-242-670-11	750
R28	1-242-683-11	2.7 k
R29	1-242-697-11	10 k
R30	1-244-719-11	82 k
R31		-----
R32	1-242-705-11	22 k

<u>Ref. No.</u>	<u>Part No.</u>	<u>Description</u>
R33	1-242-667-11	560
R34	1-242-685-11	3.3 k
R35	1-242-689-11	4.7 k
R36	1-242-689-11	4.7 k
R37	1-242-725-11	150 k
R38	1-242-670-11	750
R39	1-242-681-11	2.2 k
R40	1-242-679-11	1.8 k
R41	1-244-641-11	47
R42	1-242-715-11	56 k
R43	1-242-693-11	6.8 k
R44	1-242-689-11	4.7 k
R45	1-244-863-11	390 $\frac{1}{2}$ W
R46	1-244-857-11	220 $\frac{1}{2}$ W
R47	1-242-631-11	18
R48	1-244-802-11	1.1 $\frac{1}{2}$ W
R49	1-244-802-11	1.1 $\frac{1}{2}$ W
R50	1-242-685-11	3.3 k
R51	1-242-687-11	3.9 k
R52	1-242-742-11	750 k
R53	1-242-667-11	560
R54	1-242-673-11	1 k
R55	1-242-737-11	470 k
R56	1-202-657-11	3.3 M $\frac{1}{2}$ W composition
R57	1-242-694-11	7.5 k
R58	1-242-649-11	100
R59	1-242-633-11	22
VR1	1-224-164-00	variable, 10 k (A); TONE control
VR2	1-224-163-00	variable, 50 k (A); VOLUME control with switch (USA Model)
	1-224-354-00	variable, 50 k (A); VOLUME control with switch (Canada Model)

MISCELLANEOUS

PL1	1-518-177-00	lamp, pilot
PL2	1-518-177-00	lamp, pilot
SP	1-502-425-00	speaker, 8 Ω
S1	1-516-232-00	switch, slide; BAND selector
S3	1-516-231-00	switch, slide; LOUDNESS
	1-534-853-00	cord, ac power
	1-536-425-00	terminal; GROUND-75 Ω , FM EXT ANTENNA
	1-582-188-00	circuit board, band selector slide switch