



McIntosh

MODEL NUMBER MA 230

DATE June, 1964

MODIFICATION MA 230 serial #10C00 to # 13C03 to increase overall gain.

DESCRIPTION This modification may be incorporated in MA 230 units having the above serial numbers to increase the overall gain. The gain is increased two ways:

1. The feedback loop in the phono-tape head input stages is modified by changing the input transistor emitter resistors (R 17 and R 18) from 1.8K 5% $\frac{1}{2}$ watt to 1.2K 5% $\frac{1}{2}$ watt.
2. The volume control taper characteristic is changed to allow more amplification at a lower setting of the control knob by changing the resistors connected to the rear of the loudness control (R 39 and R 40) for 47K 10% $\frac{1}{2}$ watt to 100 K 10% $\frac{1}{2}$ watt.

These modifications have been made in all MA 230 with serial numbers above 13C03 .

McIntosh

MODEL NUMBER MA 230

DATE June, 1964

MODIFICATION MA 230 serial # 10C00 to # 17C50 to decrease hum introduced when H.F. filter switch is depressed.

DESCRIPTION This modification may be incorporated in MA 230 units with the above serial number to decrease hum introduced when the H.F. filter switch is depressed. The hum introduced comes from a 120 cycle ripple component on the filament supply coupling to the input grids of the 12AX7 tube. This coupling is eliminated by adding two resistors to balance the filament supply with respect to ground. The pilot lamp is rewired as a part of the modification.

These modification have been made in all MA 230's with serial numbers above 17C50 .

- PROCEDURE**
1. Remove bare wire from pilot light socket to ground.
 2. Remove bare wire from pin 7 of V₁ to ground.
 3. Install new wire to pilot light and two 100 ohm 10% $\frac{1}{2}$ watt resistors as shown below:

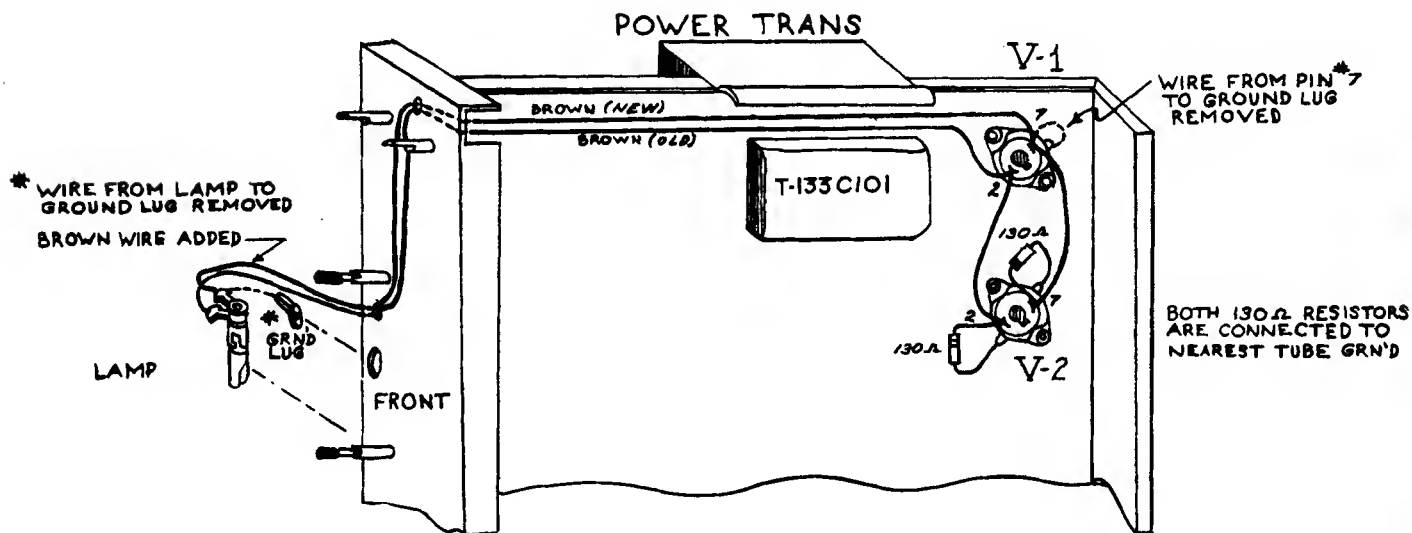

McIntosh

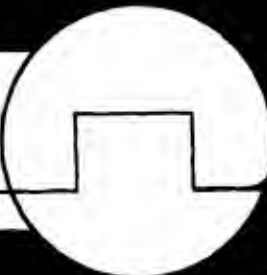

MODEL NUMBER MA 230

DATE September, 1964

MODIFICATION INSTALLATION OF A 4 SECTION VOLUME CONTROL

PROCEDURE

1. Remove the black ground wire running from the volume control to the balance control.
2. Install terminal strip on the printed circuit board. Use the existing bolt and nut.
3. Cut the audio cables attached to the card. Cut them long enough to be connected to the terminal strip as shown in the diagram.
4. Remove the existing volume control. Pay strict attention to how the wires are connected. (The two front sections of the new volume control are identical to the existing control; the two rear sections are those added.)
5. Install the new volume control and wire according to the diagram. Connect the 5 jumper wires. Make sure they are insulated from the control frame. Use insulated wire or spaghetti. Do not alter the lead arrangement or the grounding method. Hum may be introduced if you do so.

McIntosh

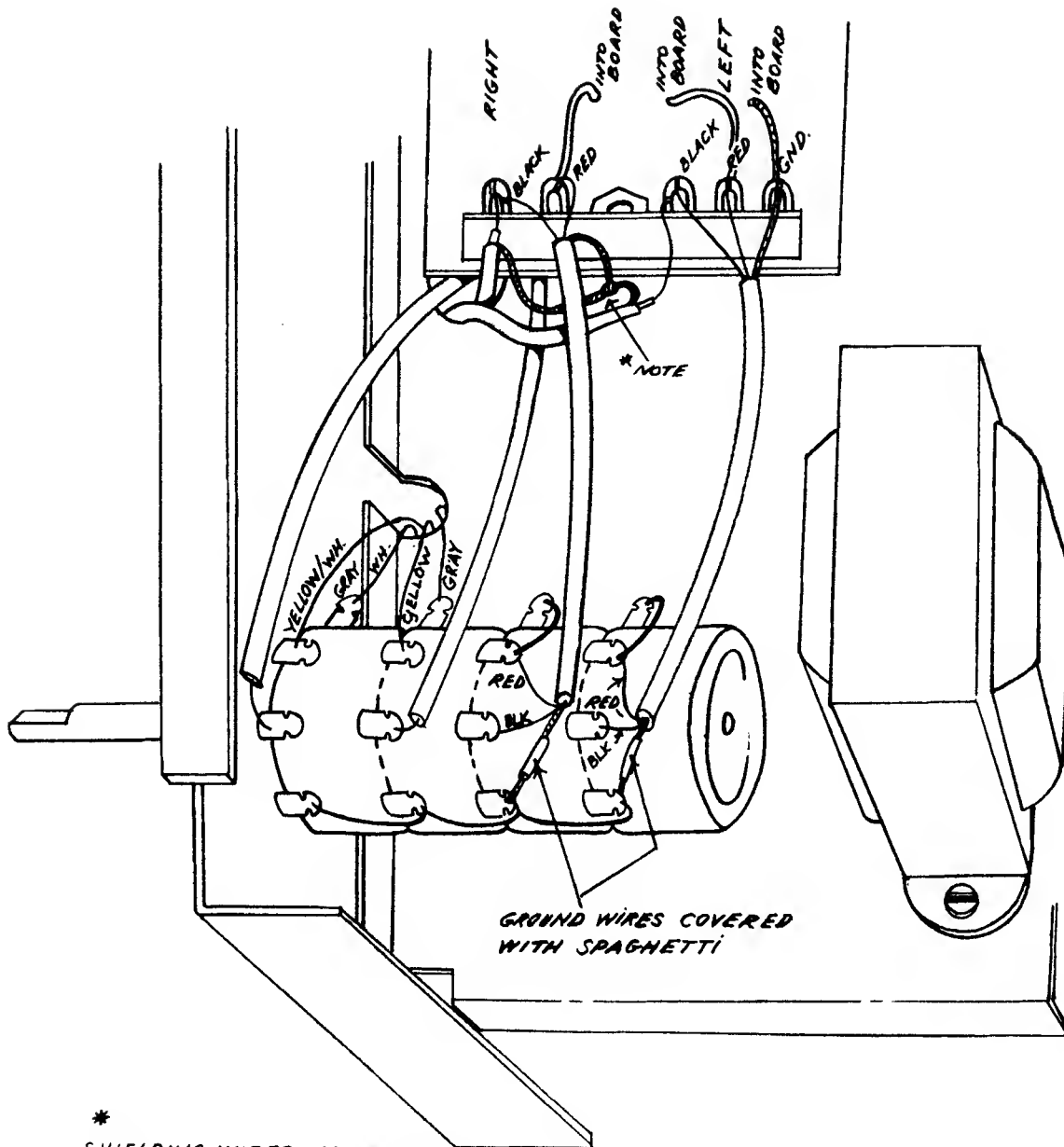

* SHIELDING WIRES FROM THESE CABLES ARE TIED TOGETHER

MA-230 INSTALLATION OF 4-SECTION VOLUME CONTROL

McIntosh

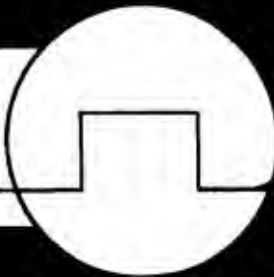

MODEL NUMBER: MI 2

DATE: MARCH 1965

MODIFICATION: To eliminate any shape other than a dot when in the "TEST" position.

DESCRIPTION: This modification can be made to all MI 2's. If a configuration other than a sharply defined spot occurs this indicates possible oscillation in the deflection amplifier. Noise in the deflection amplifier can also cause this condition. Oscillation is caused by coupling between pins 1 and 2 of tubes V1 and V3. Noise can be caused by parasitic oscillations of intensity control neon bulbs and by coupling of power line noise into the + 108 volt supply via the filament winding on the power transformer. These modifications have been made to all MI 3's.

PROCEDURE:

1. There are two 10 w resistors under the chassis, parallel each of these with a 56K 2 w resistor.
2. Remove the neon bulb from the intensity control.
3. Add a 270K ½ w resistor from the center lug of the intensity control to the side lug (at junction of yellow/white wire and 390 K resistor). Add a jumper wire from the center lug of the control to the other lug (junction of orange/white wires).
4. Remove the red/white wire from pin 5 of the 6U8 (6) to pin 1 of the OB 2 (V8). Replace the wire with a 47K ½ w resistor.
5. Add a 10pf capacitor from pin 2 to pin 6 of tubes V1 and V3. Bend the tube socket of pins of tubes V1 and V3 so that pin 1 is as far away from pin 2 as possible. Dress the leads connecting to these pins for maximum separation.

VERTICAL AMPLIFIER

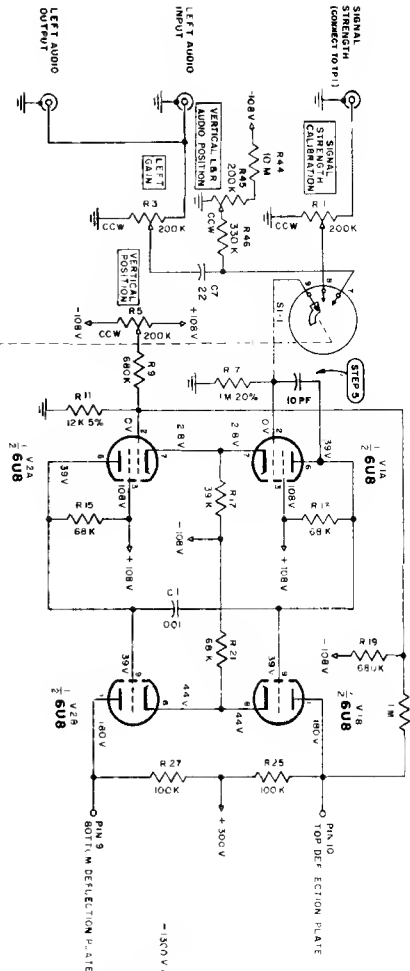

C.R.T. CIRCUIT

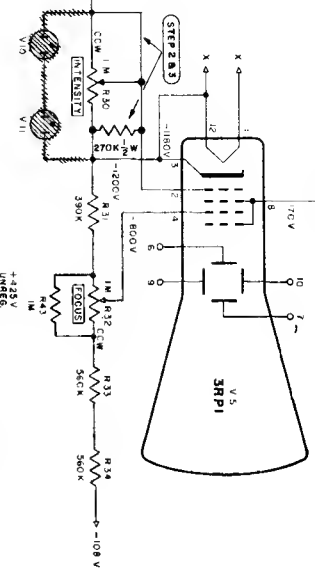

VOLTAGE REGULATOR

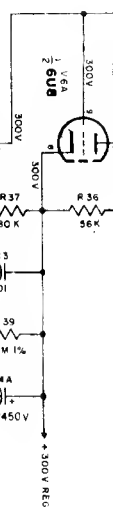

HORIZONTAL AMPLIFIER

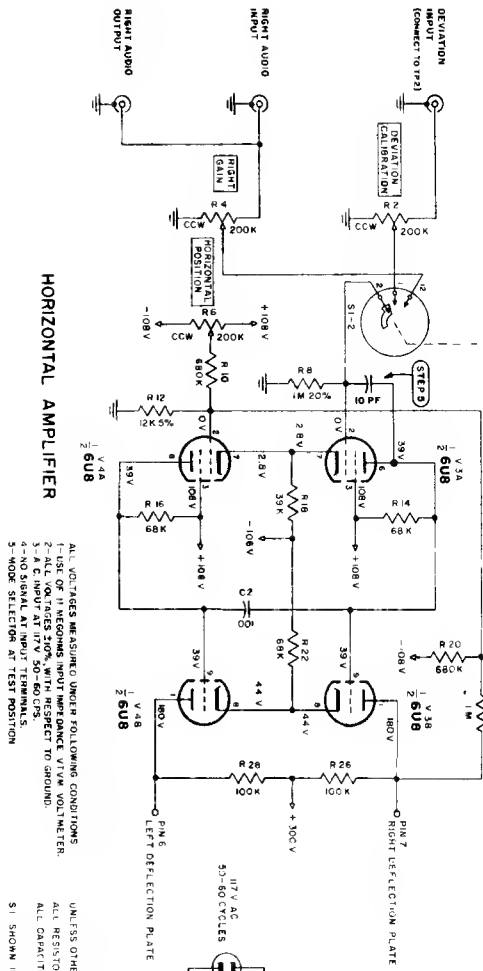

- ALL VOLTAGE MEASUREMENTS UNDER FOLLOWING CONDITIONS:
- 1- USE OF 11 MEGOHM INPUT IMPEDANCE V.T.M. VOLTMETER.
- 2- ALL VOLTAGES 50% WITH RESPECT TO GROUND.
- 3- A.C. INPUT AT 17V 50-60 CPS.
- 4- ALL CAPACITORS IN MFD.
- 5- MODE SELECTION AT TEST POSITION.
- S1 SHOWN IN CCW POSITION.

POWER SUPPLY

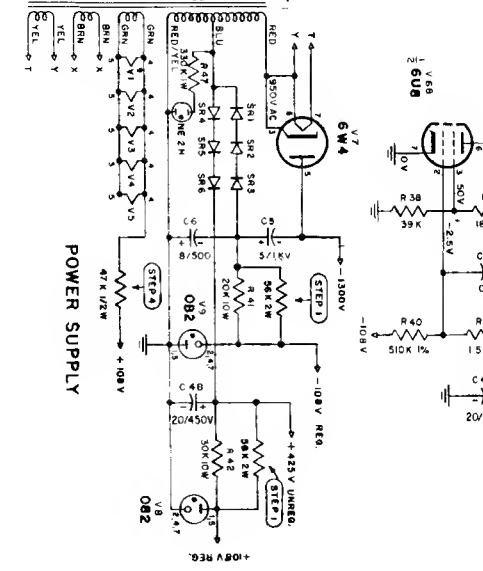

McIntosh

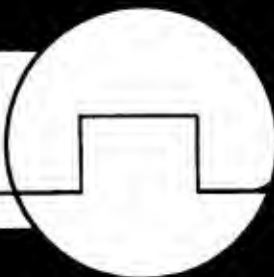

MODEL NUMBER: MI 2

DATE: MARCH 1965

MODIFICATION: To eliminate any shape other than a dot when in the "TEST" position.

DESCRIPTION: This modification can be made to all MI 2's. If a configuration other than a sharply defined spot occurs this indicates possible oscillation in the deflection amplifier. Noise in the deflection amplifier can also cause this condition. Oscillation is caused by coupling between pins 1 and 2 of tubes V1 and V3. Noise can be caused by parasitic oscillations of intensity control neon bulbs and by coupling of power line noise into the + 108 volt supply via the filament winding on the power transformer. These modifications have been made to all MI 3's.

PROCEDURE:

1. There are two 10 w resistors under the chassis, parallel each of these with a 56K 2 w resistor.
2. Remove the neon bulb from the intensity control.
3. Add a 270K ½ w resistor from the center lug of the intensity control to the side lug (at junction of yellow/white wire and 390 K resistor). Add a jumper wire from the center lug of the control to the other lug (junction of orange/white wires).
4. Remove the red/white wire from pin 5 of the 6U8 (6) to pin 1 of the OB 2 (V8). Replace the wire with a 47K ½ w resistor.
5. Add a 10pf capacitor from pin 2 to pin 6 of tubes V1 and V3. Bend the tube socket of pins of tubes V1 and V3 so that pin 1 is as far away from pin 2 as possible. Dress the leads connecting to these pins for maximum separation.

VERTICAL AMPLIFIER

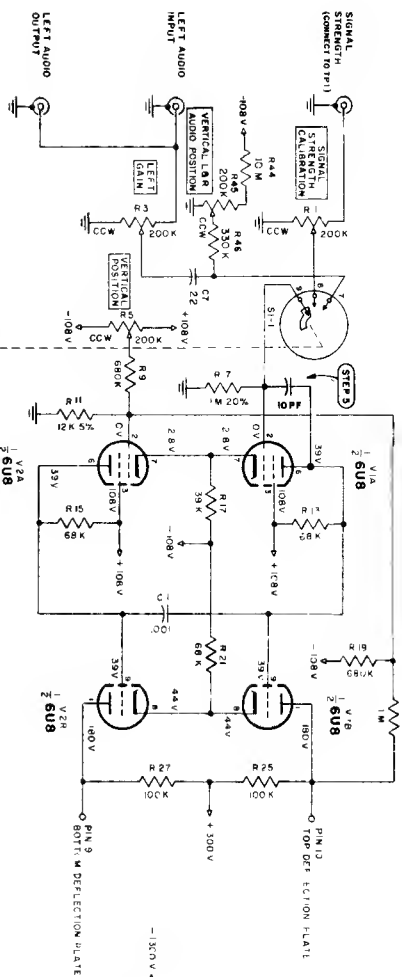

CRT CIRCUIT

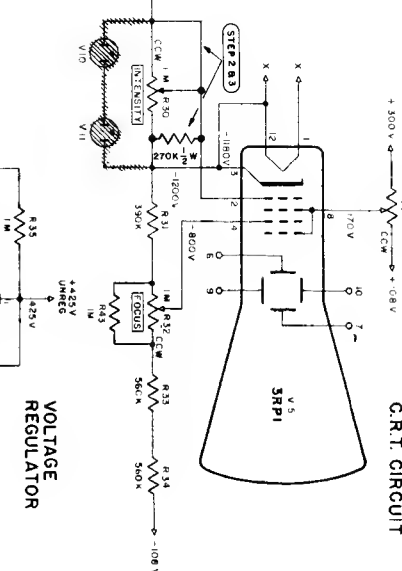

VOLTAGE REGULATOR

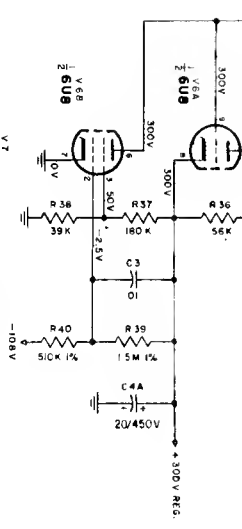

HORIZONTAL AMPLIFIER

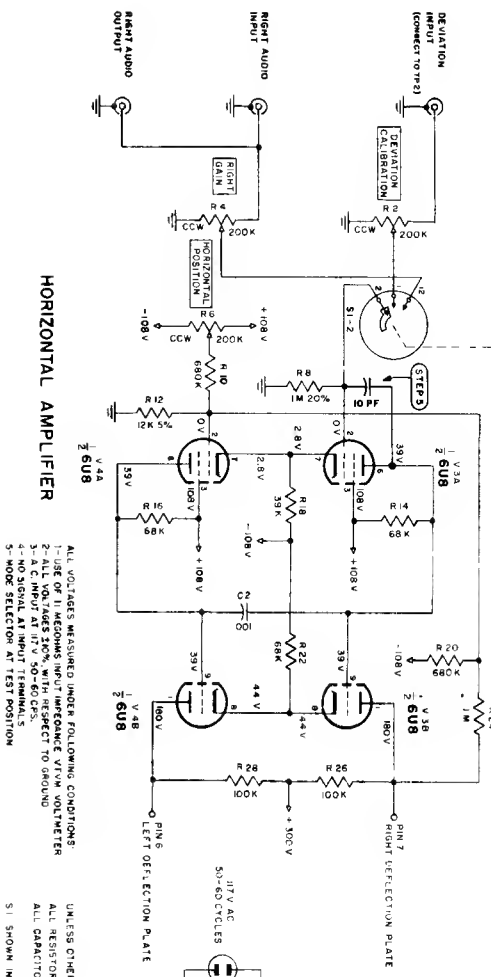

- ALL VOLTAGES MEASURED UNDER FOLLOWING CONDITIONS:
- 1- ALL VOLTAGES 10% WITH RESPECT TO GROUND
- 2- ALL VOLTAGES 10% WITH RESPECT TO GROUND
- 3- A.C. INPUT AT 10V 50-60 CPS.
- 4- NO SIGNAL AT INPUT TERMINALS
- 5- MODE SELECTION AT TEST POSITION

- UNLESS OTHERWISE SPECIFIED
- ALL RESISTORS IN OHMS, 2W, 10%
- ALL CAPACITORS IN MFD
- S1 SHOWN IN CCW POSITION

POWER SUPPLY

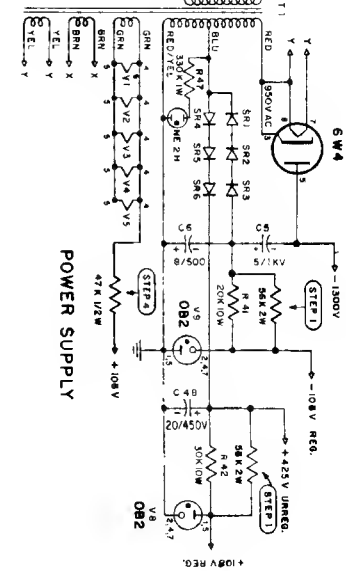

McIntosh

MODEL NUMBER: C 8, C 11, C 22

DATE: APRIL 1965

MODIFICATION: Replace the selenium rectifier with silicon rectifiers. These silicon rectifiers have much longer life.

DESCRIPTION: The original selenium rectifier in the C 8 is replaced by two (2) silicon rectifiers; the original selenium rectifier in the C 11 and C 22 is replaced by four (4) silicon rectifiers. The rectifiers are McIntosh part number 070-014, or any 50 PIV 750 MA rectifiers.

PROCEDURE: The selenium rectifier is replaced by a terminal strip and the new silicon rectifiers are installed as shown in the following diagrams.

NOTE THAT TERMINAL STRIPS ARE REQUIRED

C 8

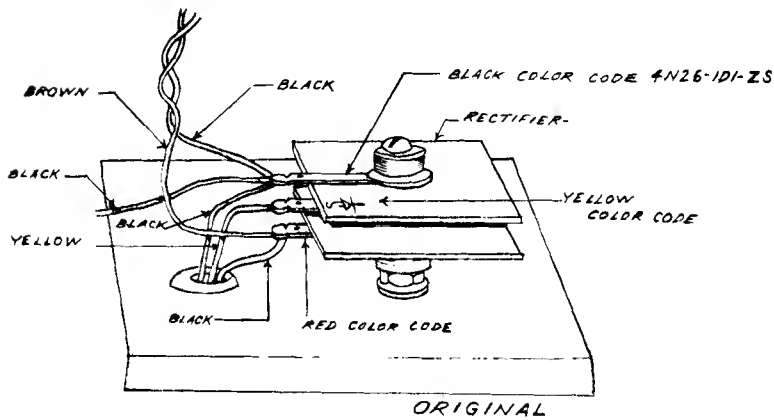

RECTIFIERS

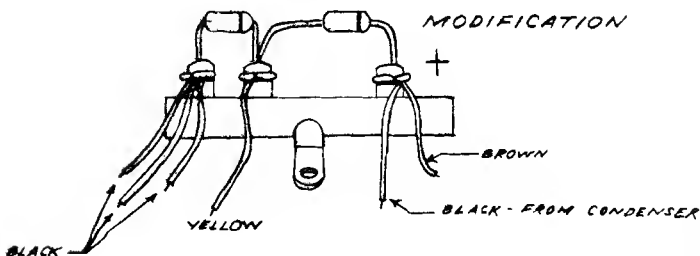

C 11, C 22

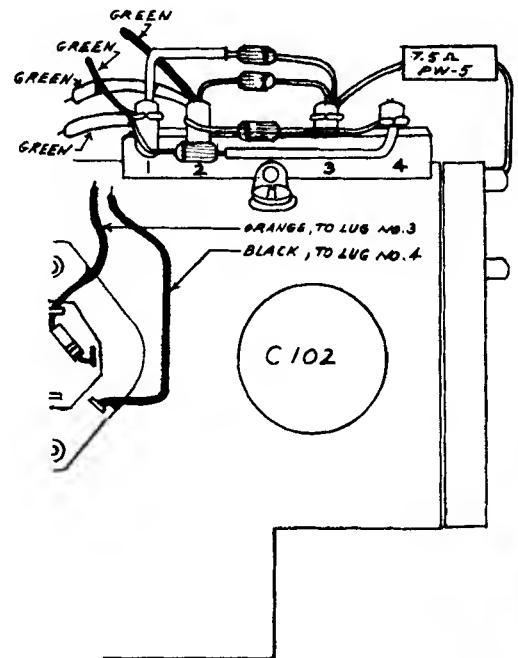

McIntosh

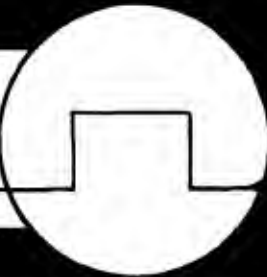

MODEL NUMBER: MA 230

DATE: MARCH 1965

MODIFICATION: Tightening the transformer mounting screws to eliminate buzzing.

DESCRIPTION: The top and bottom transformer laminations will vibrate when they are not secured by the impregnating varnish or clamped by the transformer end-bells. Some MA 230's transformers have the problem.

PROCEDURE: Tightening the transformer mounting screws may secure the laminations enough to eliminate the buzz. If this fails thin shims should be inserted between the laminations and the end bells.

TO INSERT THE SHIMS:

1. Loosen the transformer mounting screws.
2. Insert two shims under each end-bell. Make the shims from metal or fiber. The shims should be 3" x 1/2" x 1/16".
3. Re-tighten the mounting.

McIntosh

MODEL NUMBER: MR 65B, MX 110, MR 67

DATE: MARCH 1965

MODIFICATION: To allow adjust control for instant correction of tube and circuit variations. This will insure proper MPX indicator light operation.

PROCEDURE: This modification will allow you to adjust the MPX light on all tuners with ease. The reason for this modification is to allow simple field adjustment of varying tube and circuit characteristic.

MR 65B
and
MX 110 tuner/preamp.

1. Install 1K control (WC 807) to MPX chassis. Use the existing MPX chassis mounting screw.
2. Remove the 820 ohm or 1K ohm resistor. (cathode circuit of 6U8)
3. Solder one end of 470 ohm resistor to bottom hole nearest the chassis.
4. Connect a lead from other end of the resistor to the terminal lug on a 1K control.

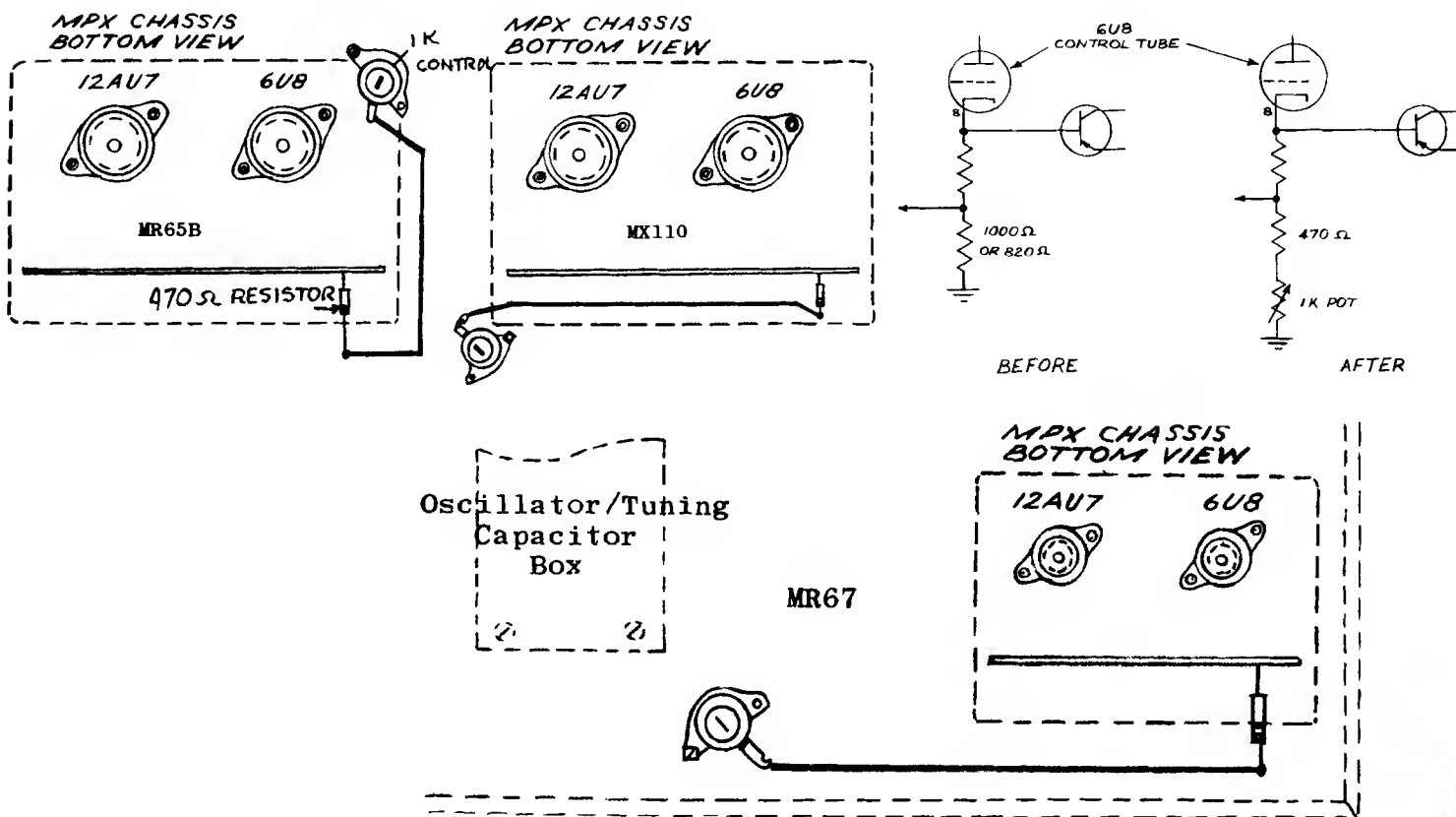

1. Install 1K control to the tuner chassis under the existing screw as shown in the diagram.

2. Follow steps 2, 3, 4, as above.

TO ADJUST THE CONTROL: Tune to point of no station. Place mute to "IN" position. Turn control from full clockwise position to a point where the light just goes out.

McIntosh

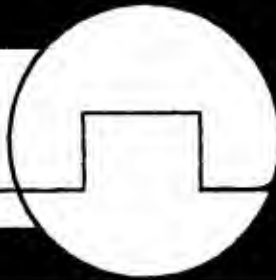

DATE: NOVEMBER, 1965

MODEL NUMBER: C 22

MODIFICATION: Replacement information for circuit modules.

PROCEDURE: C 22's built before 1965 used circuit modules made by Erie Electronics. In 1965 we changed to Sprague Electric Co. The Sprague modules are electrically equivalent to the Erie modules but differ mechanically. The newer Sprague modules are used for replacement when servicing early C 22 units.

The attached schematic shows the lead connections for both the Erie modules (PC 120-161, PC 120-133, PC 120-132, PC 120-134, PC 120-138, and PC 120-160) and the Sprague modules (130-015, 130-016, 130-017, 130-018, 130-019, 130-020, and 130-021.) Follow the schematic to replace an Erie module with a Sprague module.

NOTE: The Sprague 130-015 replaces 2 each PC 120-161 units, and a Sprague 130-018 plus a 130-019 replaces one PC 120-134.

McIntosh

DATE: NOVEMBER, 1965

MODEL NUMBER: MX110

MODIFICATION: Popping noise from the speakers when the switch controls on the MX110 are operated can be caused by "leaky" .1 MFD disc ceramic coupling capacitors. Changing these capacitors to high insulation resistance mylar units will eliminate the problem. MX110 equipment built since April 1965 have this change.

PROCEDURE: Replacement of capacitors.

- A. If a popping is heard when depressing the LF filter replace C 97 or C 98. They are located on the LF filter switch. The replacement part number is 064-027. (.1 mfd 40 v).
- B. If a popping is heard when rotating the mode selector switch replace C 93 and C 95, or C 94 and C 96. The components are to be replaced with one 064-024. (.22mfd 40v). C 97 and C 98 may also cause popping.
- C. If a popping is heard when rotating the input selector switch between MPX and AUX or FM MONO, replace C 72, C 76, or C 52. Use 061-0455. (.02 mfd)
- D. If a popping is heard when rotating the input selector switch to various positions, replace C 91 or C 92. Use 061-045. (.02 mfd).
- E. If a high level of distortion is present on FM mono, replace C 54. Use 064-028. (.1 mfd 200 v).

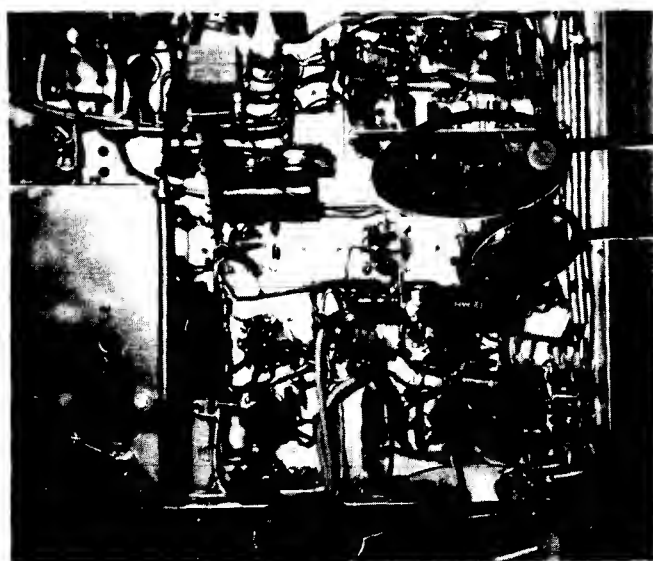

C-72, 76, 52

C-54, C-91-96 (AT 6D10 TUBE SOCKET)

C-97, 98

NOTE: All of the above replacement parts should be acquired from McIntosh Lab.

LEFT CHANNEL

- LEFT CHANNEL INPUTS**
- AUX $\text{10K } \Omega$
 - TAPE $\text{10K } \Omega$
 - TUNER 1 $\text{10K } \Omega$
 - TUNER 2 $\text{10K } \Omega$
 - PHONO 1
 - PHONO 2
 - MIC
 - TAPE HD
 - MONITOR INPUT
 - TAPE OUTPUT

LEFT TAPE

RIGHT TAPE

RIGHT CHANNEL

- RIGHT CHANNEL INPUTS**
- AUX $\text{10K } \Omega$
 - TAPE $\text{10K } \Omega$
 - TUNER 1 $\text{10K } \Omega$
 - TUNER 2 $\text{10K } \Omega$
 - PHONO 1
 - PHONO 2
 - MIC
 - TAPE HD
 - MONITOR INPUT
 - TAPE OUTPUT

* RESISTORS $\frac{1}{2}W, 20\%$

THIS DRAWING SHOWS HOW TO REPLACE DISCONTINUED SERIES MODULES WITH CURRENT SERIES MODULES.

UNLESS OTHERWISE SPECIFIED
ALL RESISTORS IN OHMS $\frac{1}{2}W, 10\%$
ALL CAPACITORS IN MFD

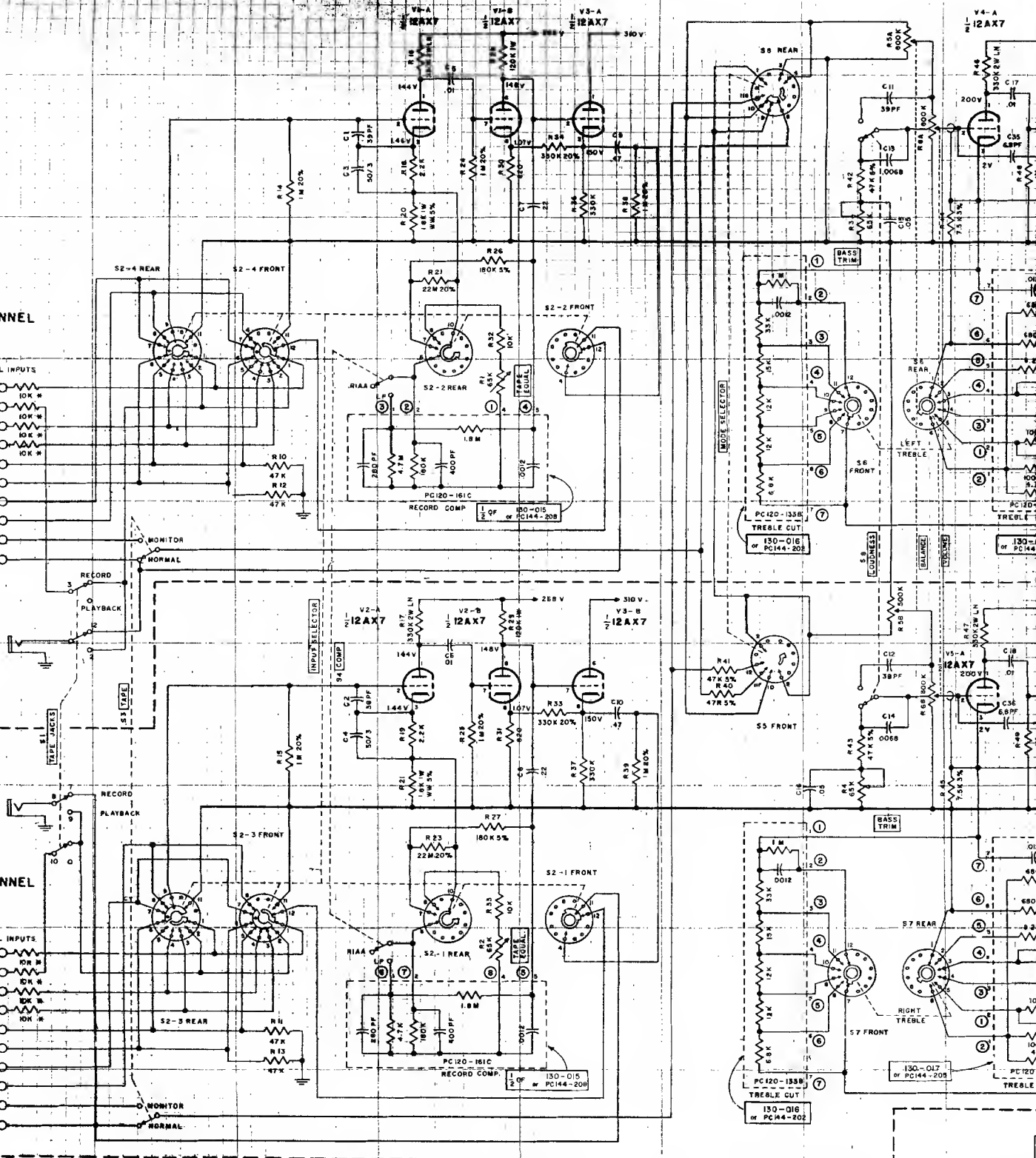

NORMAL
REVERSE

PHA

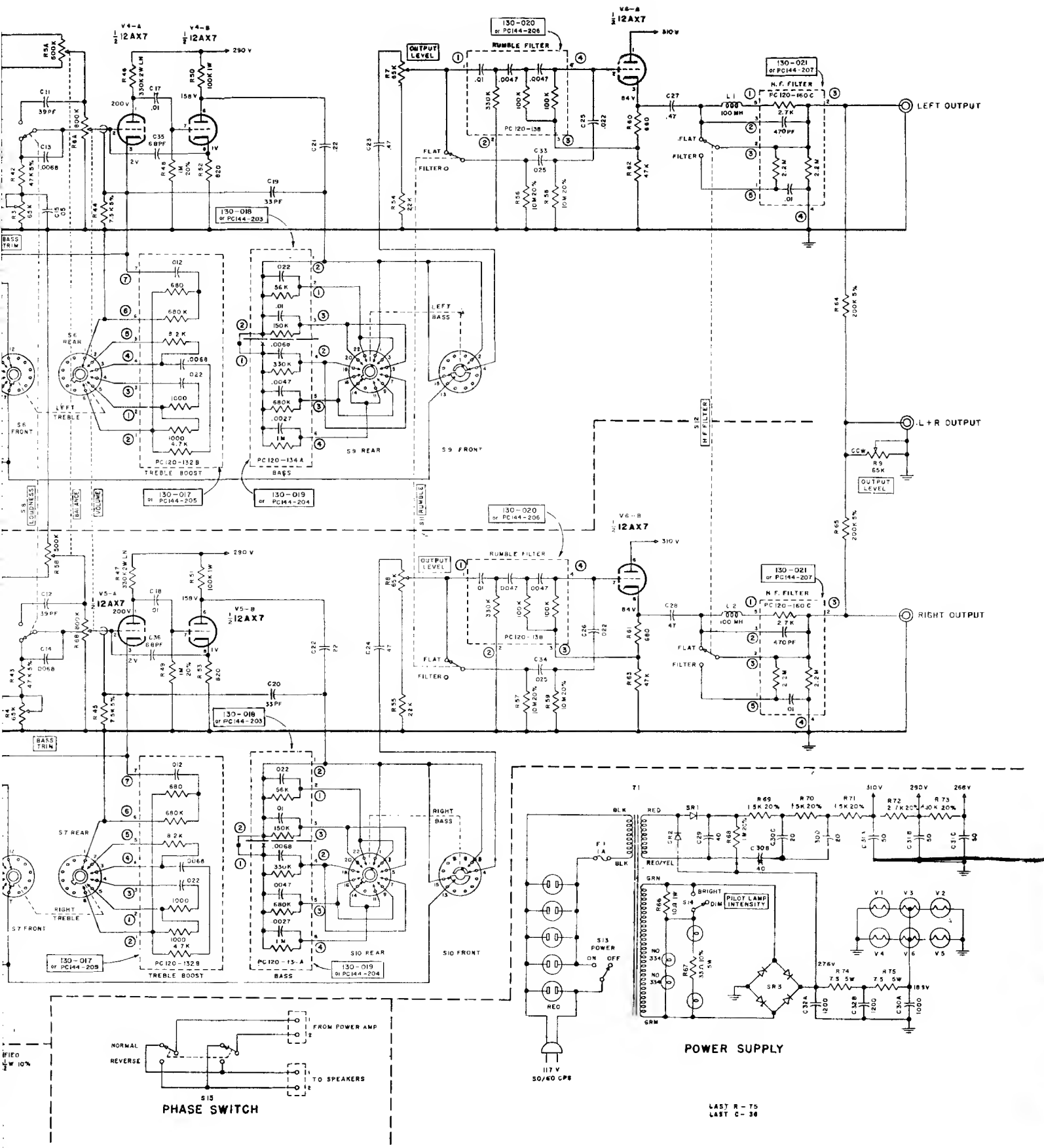

POWER SUPPLY

LAST R - 75
LAST C - 38

McIntosh

PRODUCT: MI-2/MI-3

MODIFICATION: CIRCUIT CHANGE TO PREVENT POWER TRANSFORMER FAILURE.

DESCRIPTION: Power transformers have failed in some MI-2/MI-3 units due to intermittent shorts in the 6W4 HV rectifier tube. These shorts are caused by cathode flaking in the 6W4. The problem can be eliminated by replacing the 6W4 with a 3000 volt 3MA semiconductor rectifier. This modification reduces the amount of heat generated within the MI-2/MI-3 and increases the life and reliability of the unit.

PROCEDURE:

1. Remove the MI-2/MI-3 top cover. Remove the 6W4 tube and place an octal plug (Part #127-006) in the socket.
2. Remove the MI-2/MI-3 bottom cover. Cut and remove the jumper wire connecting pin 8 to pin 3 on the 6W4 socket.
Connect the 3000 PIV rectifier (Part #070-026) to pin 5 and pin 3 of the 6W4 socket. The RED end of the rectifier should connect to pin 3 and the BLACK end to pin 5. This part of the circuit operates at -1300V; therefore, be sure to locate the rectifier and its leads to provide adequate insulation. Use spaghetti on the rectifier leads. Keep the rectifier leads short to avoid rectifier vibration problems.
3. This completes the modifications. Service bulletin 104 also relates to this product. If trouble has been experienced this modification should be installed at this time.

McIntosh

NOVEMBER, 1965

MODEL NUMBER: MAC 1500, Serial Numbers below 11F99

MODIFICATION: To increase audio gain in all input positions. This modification changes the volume control taper to give about 8db more gain. It does not increase the gain in the full volume position.

PROCEDURE: Refer to the schematic on this bulletin. Find resistors R 130 and R 131 and capacitors C 100 and C 101. These components connect to the volume control. Remove them from the receiver. Replace R 130 and R 131 with 5.6K 5% 1/4 watt resistors. Replace C 100 and C 101 with .047 mfd 10% mylar.

MATERIAL NEEDED: 2 each resistors, 5.6K 5% 1/4 watt.
2 each capacitors, .047 mfd 10% mylar.

These parts are available in modification kit #9043-543.

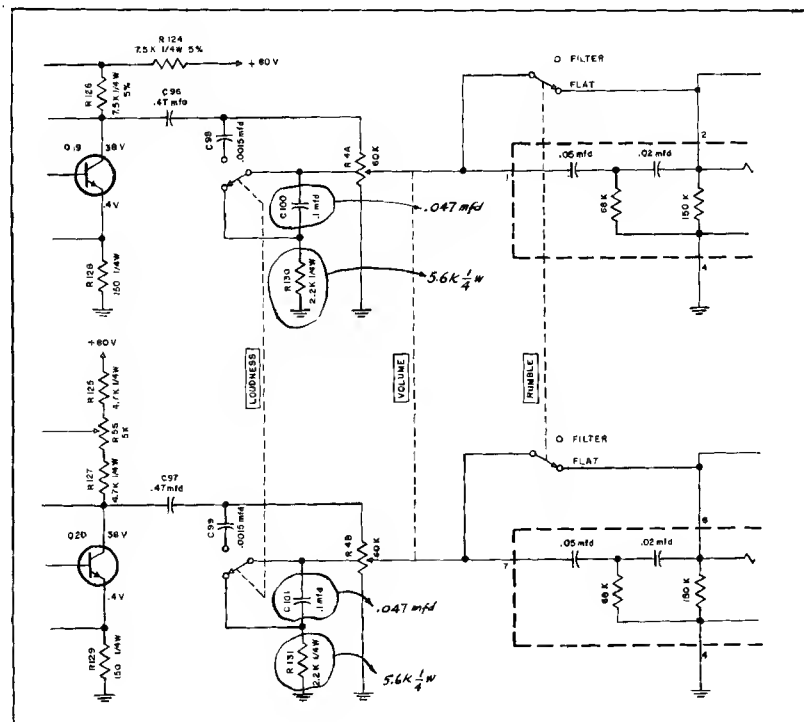



McIntosh

MODEL NUMBER: MX110 Z and X series.

DATE: JUNE 1966

MODIFICATION: This modification eliminates both the "opening" of the tuning eye after warm up, and the muting threshold change with tuner warm up.

The drift problem is corrected by replacing the IF transformer T 4. T 4 is replaced by a transformer of improved design. There are several circuit modifications that must also be made.

Part of the change includes adding a potentiometer. This potentiometer allows adjustment of the amount of tuning eye closure.

After the modification has been made it is necessary to align the IF transformer T 4, the tuning indicator adjustment, and the muting adjustment control.

PROCEDURE:

1. Remove IF transformer T 4. Replace this transformer with McIntosh part #162-029. Remove and do not connect back into the circuit capacitor C 24 and the small parallel lead capacitor that was between pins 1 and 4 on the transformer.
2. Replace diode D2 with a new diode, McIntosh part #070-022.
3. Change R 33 from 100K to 47K 10% 1/2W. This is McIntosh part #136-180.
4. Remove the present muting control. Discard it. Install a dual control. (#134-168). The top of the dual control is re-wired as the previous muting control. The bottom of the control is the new control.
5. Connect the end contact of the tuning indicator adjust control to the end contact of R1.
6. Remove resistor R 35. Replace it with a short section of wire. Solder the wire to ground.
7. Disconnect the end of R 32 which connects to feed through capacitor C33. Connect this end of R 32 to the form contact on the tuning indicator adjust control. To make this connection extend the lead on R 32. Use a short section of wire and spaghetti tubing.
8. Align and adjust the MX 110 as follows: If proper alignment equipment is at hand use procedure A. If limited test equipment is available use procedure B.
 - A) Switch the MX 110 muting control to the "out" position. Connect a 10.7MC signal to the grid of the first IF amplifier. Feed in enough signal to develop at least 10 volts at test point 1 (TP-1). Turn the "tuning indicator adjust" control to mid position. Adjust T-4 top and bottom cores for maximum tuning indicator closure. Then adjust the "tuning indicator adjust" control for 1/16" opening of the tuning eye.
 - With the 10.7MC signal connected to the MX 110 check the adjustment of IF transformer T 5. Measure the DC voltage present at test point 2 (TP-2). If this voltage measures more than ± 0.2 volts, adjust the top core on T 5 so the voltage at TP-2 is zero. DO NOT ADJUST THE BOTTOM CORE OF T 5.

McIntosh

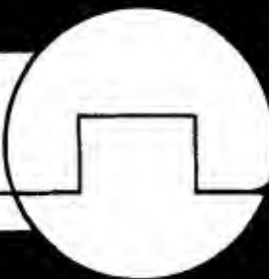

Next feed a 6 microvolt FM signal into the antenna terminals of the MX 110. Tune the MX 110 to the FM signal generator. Modulate the FM signal generator with a 400 cps or 1000 cps audio signal. Switch the muting switch to the "in" position. Adjust muting control R1 so the MX 110 output just starts to mute.

THIS COMPLETES THE ADJUSTMENT PROCEDURE.

IF YOU DO NOT HAVE TEST EQUIPMENT USE THE FOLLOWING ADJUSTMENT PROCEDURE.

B) Switch the muting switch to the "out" position. Connect a FM antenna to the MX 110. Tune in a strong local station. Connect a DC voltmeter to test point 2 (TP-2). Carefully tune the MX 110 tuning knob for zero volts at TP-2. Adjust the "tuning indicator adjust" control to mid position. Adjust T4 top and bottom cores for maximum tuning indicator closure. Then adjust the "tuning indicator adjust" control for 1/16" opening of the tuning indicator.

Next tune in a weak station. The station should have background noise but still be listenable. Switch the muting switch to the "in" position. Adjust the "muting adjust" control R1 so the MX 110 output just starts to mute.

THIS COMPLETES THE ADJUSTMENT PROCEDURE.

PARTS NEEDED:

- 1 162-029 IF Transformer
- 1 070-022 Diode
- 1 136-180 47K Resistor
- 1 134-168 Control

McIntosh

PROCEDURE FOR MOUNTING "TUNING INDICATOR ADJUST" CONTROL

- ① CHANGE T4 TO PART # i62-029. REMOVE C 34 AND PARALLEL WIRE CAPACITOR.
- ② CHANGE D2 TO PART # 070-022.

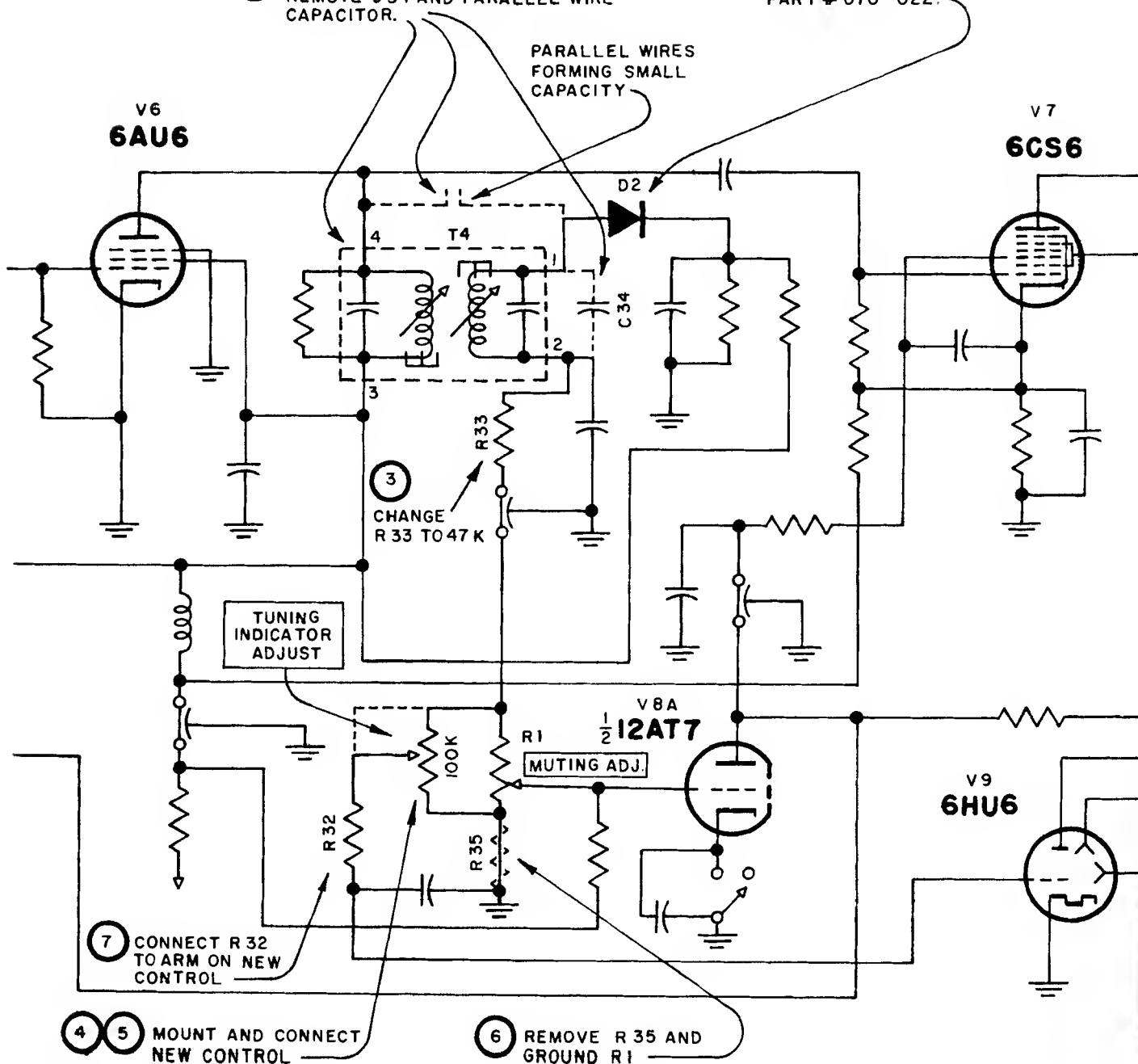

McIntosh

MODEL NUMBER: C 24

MODIFICATION: Add four grounding springs to the shafts of the Volume, Balance, Bass and Treble controls.

DESCRIPTION: Some controls have developed a noise when rotated. Adding the springs to ground the shafts prevents this condition.

CAUTION: When adding the springs to the Bass and Treble control, be sure they make good contact. Make sure the spring is not too tight. If the springs are tight the clutch action of the controls will not function.

PROCEDURE: Remove the front panel. Place the spring around the shaft and insert the ends of the spring into the control guide hole. See diagram.

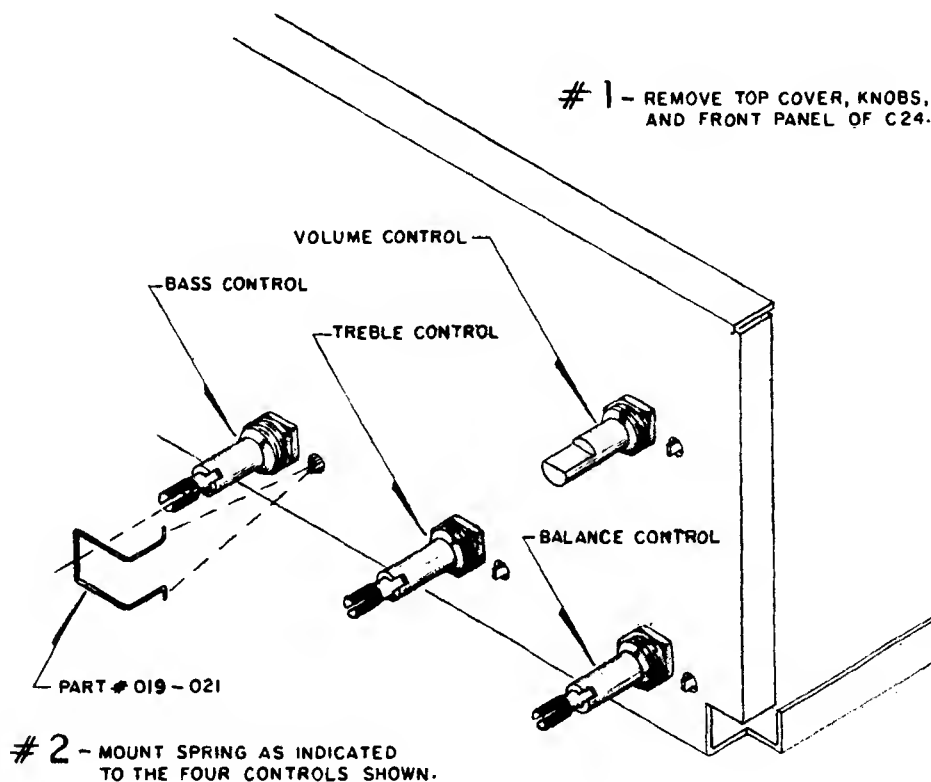

MODEL NUMBER: MR 71

MODIFICATION: This modification increases stereo separation on MR 71 tuners to better than 35 db separation. This modification is in units with serial numbers above 45B00.

DESCRIPTION: The stereo multiplex detector in the MR 71 tuner is a self matrixing detector. It automatically recombines the L+R and L—R stereo information to produce L and R output. The SCA filter causes a slight loss in the L—R portion of the composite multiplex signal. This limits stereo separation to about 30 db. Separation is improved by increasing the difference signal gain in the tuner left and right audio amplifiers while leaving the common signal gain unchanged. This is done by connecting a RC network between the cathodes of the R and L input audio amplifier stages.

PROCEDURE:

1. Connect a 27K 5% ½ watt resistor and a .0015 MF 10% capacitor in parallel. Connect this network between pin #8 on one 6BL8 audio tube to pin #8 on the other 6BL8 audio tube.
2. Feed a multiplex signal modulated with 1KC audio left or right channel only into the tuner antenna input. Tune the tuner to the MPX signal. Align the 19KC phase adjust (coil L5) for maximum stereo separation. It is possible to obtain greater than 35 db separation between channels.

NOTE: Before making this alignment be sure the MPX generator is accurately set up. View the composite stereo signal at the generator with an oscilloscope. Do not attempt to estimate stereo separation by viewing the tuner discriminator output at TP 2. The signal at TP 2 should **NOT** look like an ideal multiplex signal.

MATERIAL NEEDED: 1. ea. resistor, 27K 5% ½w
1. ea. capacitor, .0015 MFD 10%

McIntosh

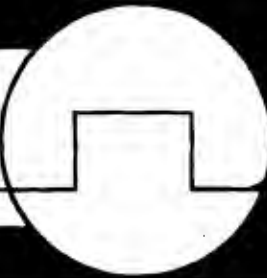

PILOT LAMP REPLACEMENT

To insure long life of festoon pilot lamps, always replace them in pairs in the C22. The two lamps are connected in series. As the lamps age their resistance increases. If only one lamp is replaced the older lamp will have higher resistance than the new lamp. This will cause more voltage to be present across the older lamp. The higher voltage will cause the older lamp to burn out more quickly than it otherwise would.

McIntosh festoon pilot lamps are designated part number 058-011. Specially-selected lamps are available for the C22. When ordering lamps for the C22, please request by part number "058-011 GREEN DOT". Use only the "GREEN DOT" lamp in the C22. Do not use them in any other product.

Al Hyle, Service Manager

McIntosh

MC-2505 SOLID STATE AMPLIFIER

Page -1-

Servicing the McIntosh MC-2505 solid state amplifier is easy. Transistor and tube type amplifiers have much in common. It is necessary to learn only a few basic principles.

1. Being a solid state amplifier, the circuits are in operation the moment the instrument is turned on. It is important to be certain that all circuits are operating properly before applying full line voltage. If some circuits are not operating properly, it is possible to damage additional circuit components. Therefore, when a McIntosh MC-2505 comes in for service, NEVER JUST PLUG IT IN AND TURN IT ON. Turn the MC-2505 on/off switch on, but turn the speaker switch off. Always use a Variac or Powerstat. Plug the amplifier into the Variac, but set the Variac output to zero volts. Bring the line voltage to the amplifier up very slowly. As you do so, monitor the output voltage on each channel. This is done with a VTVM. Connect the VTVM common lead to the chassis and the probe to the point shown:



POWER OUTPUT PRINTED CIRCUIT BOARD

Set the VTVM on about a 15 volt positive DC scale. Set the needle of the VTVM to the center of the scale rather than to zero. As the line voltage to the amplifier is slowly increased, the VTVM needle will swing positive a few volts, then back past the center position, then slightly negative, then return to center position. This complete cycle will occur before the line voltage to the

amplifier reaches 30 volts. Raise the line voltage from zero to 30 volts very slowly. Alternate the VTVM probe between the two channels. There may be trouble in only one channel. The channel without the trouble would give a correct indication on the VTVM. So it is necessary to monitor both channels as the amplifier is being turned on.

2. This step tells how to adjust the bias. It applies only to amplifiers bearing 10K01 through 14K84. Amplifiers bearing serial number 14K85 and up have no bias adjustments to be made. If the amplifier has turned on with no indication of trouble, the next step is to set the bias. By means of the bias pot on the power output printed circuit board, adjust the bias for 40 millivolts. Do this for each channel. This adjustment should be made when the amplifier is cold. Make it within the first minute or so after the amplifier has been turned on. The bias will vary somewhat as the amplifier warms up. Do not re-adjust the bias. The bias adjustment is made with the VTVM connected as shown:

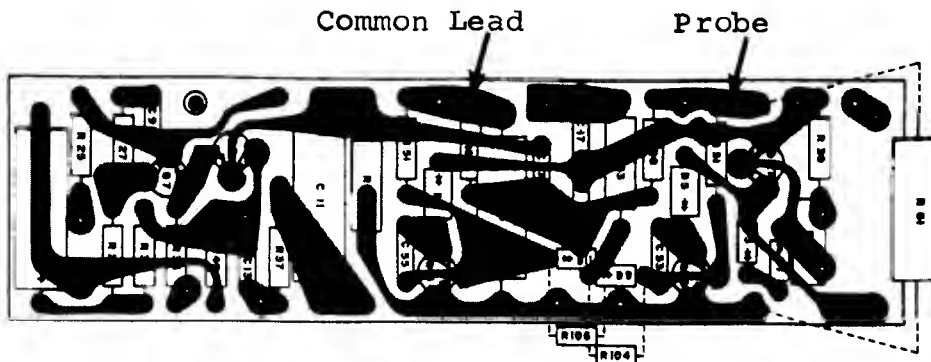

POWER OUTPUT PRINTED CIRCUIT BOARD

3. If there is trouble in one channel, you will not see the indication on the VTVM described in point 1. Stop right there. There are basically three possibilities of incorrect indication. The VTVM needle may not move at all, it may continue to swing positive, or it may continue to swing negative.

McIntosh

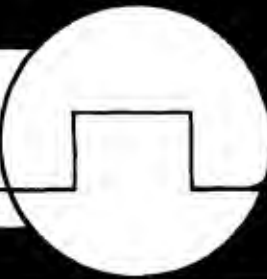

Page -3-

4. Regardless of the incorrect indication, it is usually not difficult to find the source of trouble. Turn the line voltage completely off. Discharge the large filter capacitors. Do not discharge the capacitors by shorting them directly to the chassis. Because of the arcing that will occur, the chassis will be marred. The proper way to discharge these capacitors is with a resistor. Use a resistor of at least a two watt rating whose value is approximately 5 to 15 ohms. Hold it across each of the large filters. In this way the power supply will be safely discharged. Failure to discharge the power supply before working on the amplifier could cause several transistors to be destroyed.

5. After the power supply is discharged, check each transistor. This is done quite easily with the VTVM. CAUTION: USE VTVM SUCH AS THE RCA SENIOR VOLTOHMYST. Do not use older 1,000 ohms per volt VOM. This type of instrument may destroy the transistor by introducing excessive current into the transistor. Set the VTVM to measure ohms; after the power supply is discharged, check each transistor. Set the VTVM to measure ohms; use the "R x 1" scale. Measure across each junction of the transistor. Measure from base to collector, base to emitter, emitter to collector, emitter to base, collector to emitter, and collector to base. Also measure from the case of the transistor to ground. In no case should there be a direct short. In most cases, only one channel of the amplifier will be defective. Therefore, until you become familiar with the readings to expect in each case, compare the defective channel with the good channel. Although a defective transistor will usually be indicated by a direct short, this is not always the case. It is possible for a difference of only 2 or 3 ohms to indicate a defective transistor. For example, if a transistor in the defective channel reads 12 ohms from one junction to another, and the similar transistor in the good channel reads 10 ohms, the transistor which reads 12 ohms is probably defective.



McIntosh

Page -4-

6. If the transistors all measure correct, check the power resistors at the emitter and collector of the output transistors. These will have a very low resistance of about .33 ohms to .56 ohms. You may find that one of these resistors has opened up.
7. On units having a bias potentiometer, always check it for continuity. Be certain that it has not opened up.
8. After replacing a defective part, always turn the amplifier on as described in point 1. Otherwise, you may damage more parts. For example, you may find a shorted output transistor. You will replace the transistor. If there are other defective parts, that you do not yet know about, and you turn the amplifier on directly, in all probability, you will damage the new transistor that you have just installed.
9. Before working on a solid state amplifier, ALWAYS discharge the power supply as described in point 4. If you do not do so, and then begin probing with a soldering aid, VTVM probe, or what have you, in all probability you will damage some transistors when you accidentally short from certain places to ground!
10. If the difficulty is not located as described in points 5, 6, and 7 you may turn the amplifier partially on. Bring the line voltage up to 25 or 30 volts. This will be enough voltage to enable you to signal-trace, compare voltages between the good channel and the defective one, etc. without damaging any components.

McIntosh

MC-2505 SOLID STATE AMPLIFIER

Page -1-

Although the MC2505 is rated at 50 watts (sine wave) per channel, it will normally put out at least 75 watts per channel. However, it is possible to drive the amplifier even harder than this. The following modification will improve the power output capabilities when the amplifier is loaded with a mis-matched load. It will also eliminate the possibility of any noise from the power supply being heard through the speakers when the amplifier is turned on and off.

This modification pertains to amplifiers bearing serial numbers 10K01 through 11K54. Amplifiers having a higher serial number than 11K55 have been modified.

It is necessary to change 2 resistors and 2 capacitors on each power output printed circuit board. A resistor is added to the board. In addition, 1 resistor is changed in the power supply and a diode and capacitor are added.

Add a 3.3K resistor

Change R-99 from 220 ohms
to 130 ohms

Change R-62 from
.56 ohms to .33 ohms

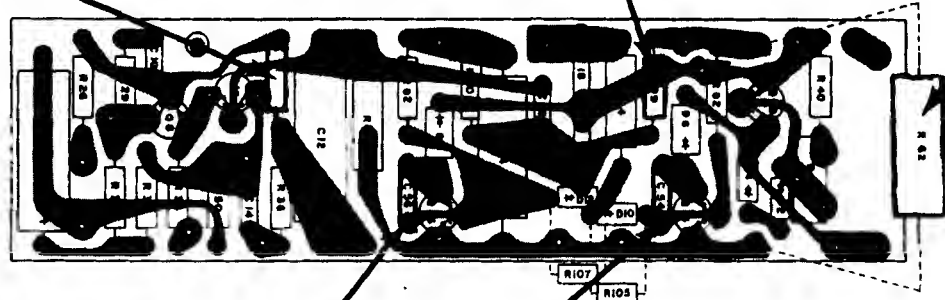

Change C-56 and C-54
from .01 mfd to .047 mfd

The right channel power output printed circuit board is shown. Do likewise on the left channel board.

Add a .22mfd, 250 volt capacitor from the -40 volt supply to ground as shown below:

McIntosh

Page -2-

Connect the Capacitor
Here

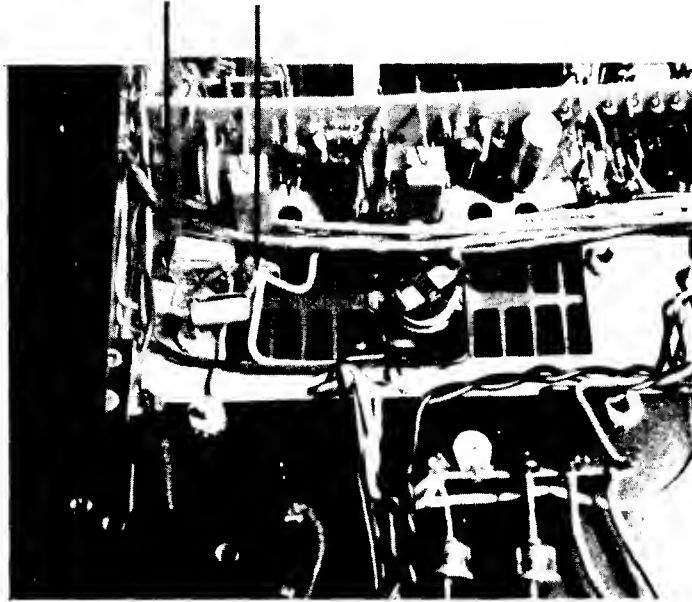

There are two terminal strips mounted on the chassis between the large electrolytic filter capacitors. There are four 2 watt resistors and 1 5 watt resistor soldered to these terminal strips. There is a red/white wire connected to one side of a terminal strip at R91. R91 is now a 270 ohm, 2 watt resistor. Change this resistor to a 220 ohm, 2 watt resistor. Remove the red/white wire that is connected here. Connect it to C-33D as shown in the picture. Also, from C-33D and the junction where the wire was formerly connected, install a diode.

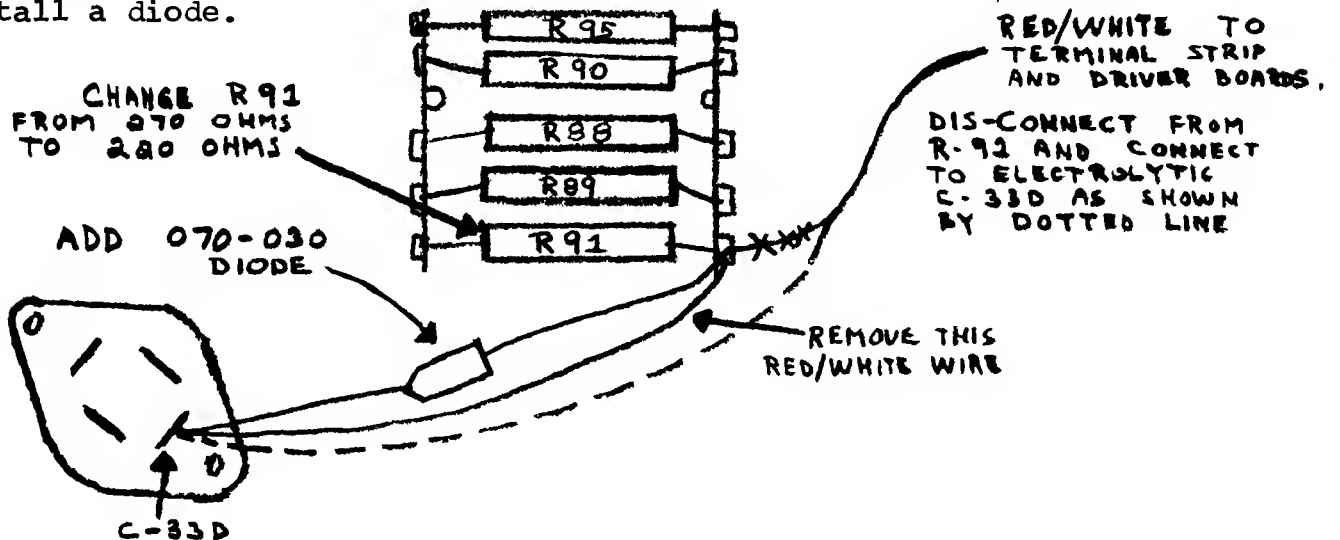

McIntosh

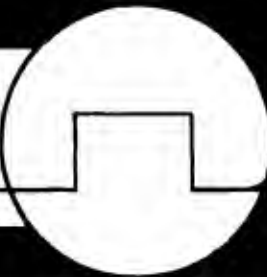

Page -3-

After the modification is made, no adjustments are necessary.

Parts required:

2 - .33 ohm, 5W resistors	McIntosh part #139-036
2 - 130 ohm, 1/2W resistors	McIntosh part #136-073
2 - 3.3K ohm, 1/2W resistors	McIntosh part #136-131
1 - 220 ohm, 2W resistor	McIntosh part #139-042
4 - .047mfd, 250 volt capacitors	McIntosh part #064-044
1 - .22mfd, 250 volt capacitor	McIntosh part #064-043
1 - Diode	McIntosh part #070-030

When ordering these parts, ask for McIntosh parts kit number 9043-664.

McIntosh

The following schematics show the changes:

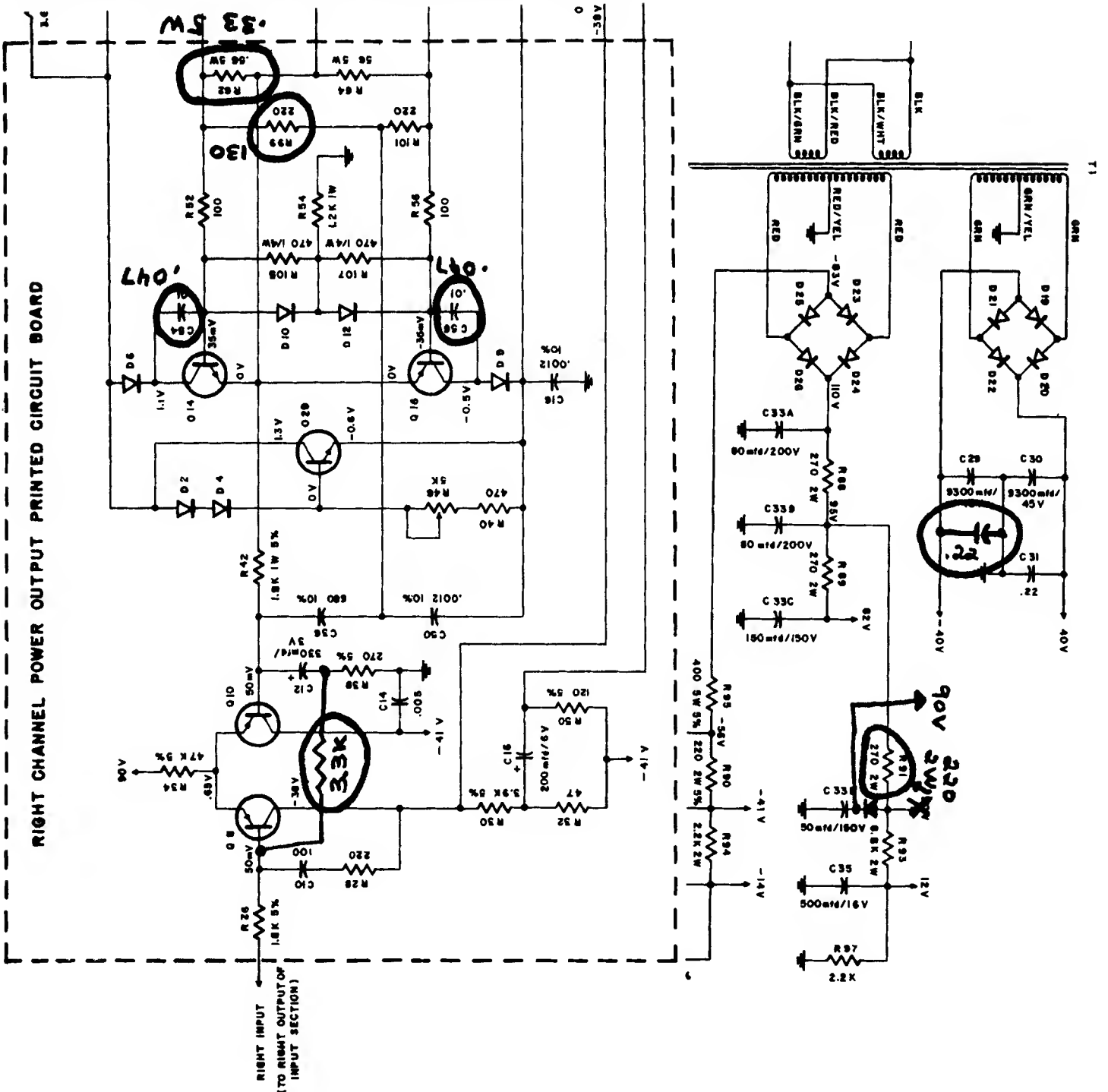

McIntosh

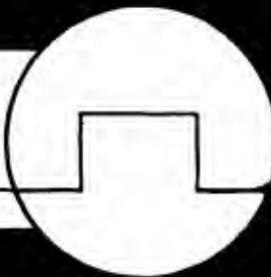

MAC-1700 RECEIVER (POWER AMPLIFIER SECTION)

Page -1-

Servicing the MAC-1700 solid state amplifier section is easy. Transistor and tube type amplifiers have much in common. It is necessary to learn only a few basic principles.

1. Being a solid state amplifier, the circuits are in operation the moment the instrument is turned on. It is important to be certain that all circuits are operating properly before applying full line voltage. If some circuits are not operating properly, it is possible to damage additional circuit components. When a MAC-1700 comes in for service, NEVER JUST PLUG IT IN AND TURN IT ON. Always use a Variac or Powerstat. Plug the receiver into the Variac, but set the Variac output to zero volts. Bring the line voltage to the receiver up very slowly. As you do so, monitor the output voltage on each channel. This is done with a VTVM. Connect the common lead of the VTVM to the speaker common terminal or the chassis and the probe to the "hot" speaker terminal. Set the VTVM on about a 15 volt positive DC scale. Set the needle of the VTVM to the center of the scale rather than to zero. As the line voltage to the amplifier is slowly increased, the VTVM needle will swing positive a few volts, then back past the center position, then slightly negative, then return to center position. This complete cycle will occur before the line voltage to the amplifier reaches 30 volts. Raise the line voltage from zero to 30 volts very slowly. Alternate the VTVM probe between the two channels. There may be trouble in only one channel. The channel without the trouble would give a correct indication on the VTVM. So it is necessary to monitor both channels as the amplifier is being turned on.
2. If the receiver is turned on with no indication of trouble, the next step is to set the bias. By means of the bias pot on the power output printed circuit board, adjust the bias for 40 millivolts. Do this for each channel. This adjustment should be made when the amplifier is cold. Make it within the first minute or so after the amplifier has been turned on. The bias will vary somewhat as the amplifier warms up. Do not

McIntosh

Page -2-

readjust the bias. The bias adjustment is made with the VTVM connected as shown:

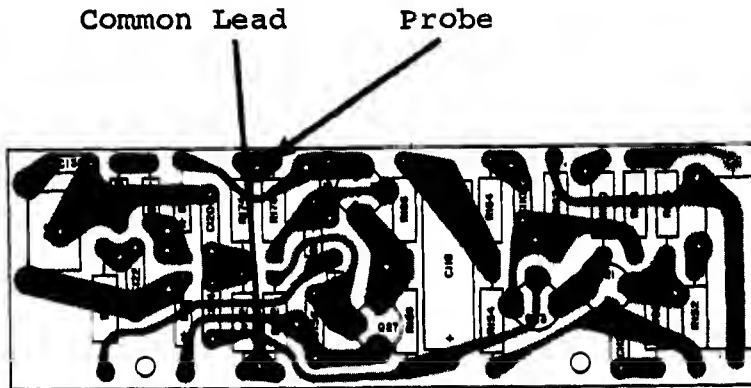

POWER OUTPUT PRINTED CIRCUIT BOARD

3. If there is trouble in one channel, you will not see the indication on the VTVM described in point 1. Stop right there. There are basically three possibilities of incorrect indication. The VTVM needle may not move at all, it may continue to swing positive, or it may continue to swing negative.
4. Regardless of the incorrect indication, it is usually not difficult to find the source of trouble. Turn the line voltage completely off. Discharge the large filter capacitors. Do not discharge the capacitors by shorting them directly to the chassis. Because of the arcing that will occur, the chassis will be marred. The proper way to discharge these capacitors is with a resistor. Use a resistor of at least a two watt rating whose value is approximately 5 to 15 ohms. Hold it across each of the large filters. In this way, the power supply will be safely discharged. Failure to discharge the power supply before working on the amplifier could cause several transistors to be destroyed.

McIntosh

Page -3-

5. After the power supply is discharged, check each transistor. This is done quite easily with the VTVM.
CAUTION: USE VTVM SUCH AS THE RCA SENIOR VOLTOHMYST. Do not use older 1,000 ohms per volt VOM. This type of instrument may destroy the transistor by introducing excessive current into the transistor. Set the VTVM to measure ohms; after the power supply is discharged, check each transistor. Set the VTVM to measure ohms; use the "R x 1" scale. Measure across each junction of the transistor. Measure from base to collector, base to emitter, emitter to collector, emitter to base, collector to emitter, and collector to base. Also measure from the case of the transistor to ground. In no case should there be a direct short. In most cases, only one channel of the amplifier will be defective. Therefore, until you become familiar with the readings to expect in each case, compare the defective channel with the good channel. Although a defective transistor will usually be indicated by a direct short, this is not always the case. It is possible for a difference of only 2 or 3 ohms to indicate a defective transistor. For example, if a transistor in the defective channel reads 12 ohms from one junction to another, and the similar transistor in the good channel reads 10 ohms, the transistor which reads 12 ohms is probably defective.
6. If the transistors all measure correct, check the power resistors at the emitter and collector of the output transistors. These will have a very low resistance of about .33 ohms to .56 ohms. You may find that one of these resistors has opened up.
7. Always check the bias potentiometer for continuity. Be certain that it has not opened up.
8. After replacing a defective part, always turn the amplifier on as described in point 1. Otherwise, you may damage more parts. For example, you may find a shorted output transistor. You will replace the transistor. If there are other defective parts, that you do not yet know about, and you turn the amplifier on directly, in all probability, you will damage the new transistor that you have just installed.

McIntosh

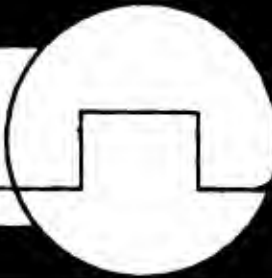

Page -4-

9. Before working on the MAC 1700 amplifier section, ALWAYS discharge the power supply as described in point 4. If you do not do so, and then begin probing with a soldering aid, VTVM probe, or what have you, in all probability, you will damage some transistors when you accidentally short from certain places to ground!
10. If the difficulty is not located as described in points 5, 6, and 7 you may turn the amplifier partially on. Bring the line voltage up to 25 or 30 volts. This will be enough voltage to enable you to signal-trace, compare voltages between the good channel and the defective one, etc. without damaging any components.

McIntosh

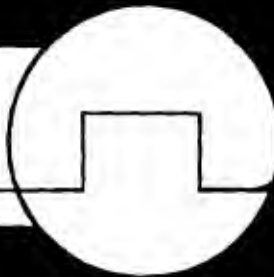

MA-5100 SOLID STATE INTEGRATED AMPLIFIER

Page -1-

Servicing the McIntosh MA-5100 solid state amplifier is easy. Transistor and tube type amplifiers have much in common. It is necessary to learn only a few basic principles.

1. Being a solid state amplifier, the circuits are in operation the moment the instrument is turned on. It is important to be certain that all circuits are operating properly before applying full line voltage. If some circuits are not operating properly, it is possible to damage additional circuit components. When a McIntosh MA-5100 comes in for service, NEVER JUST PLUG IT IN AND TURN IT ON. Always use a Variac or Powerstat. Plug the amplifier into the Variac, but set the Variac output to zero volts. Bring the line voltage to the amplifier up very slowly. As you do so, monitor the output voltage on each channel. This is done with the VTVM. Connect the VTVM common lead to the chassis. On MA-5100 amplifiers bearing serial number 10H01 through 20H99, touch the probe to the points shown:



McIntosh

Page -3-

- b) Serial number 13H00 and above. Set the bias for 30 millivolts.

The bias adjustment is made as follows:

- a) If the serial number is 10H01 through 20H99, connect the VTVM as shown:

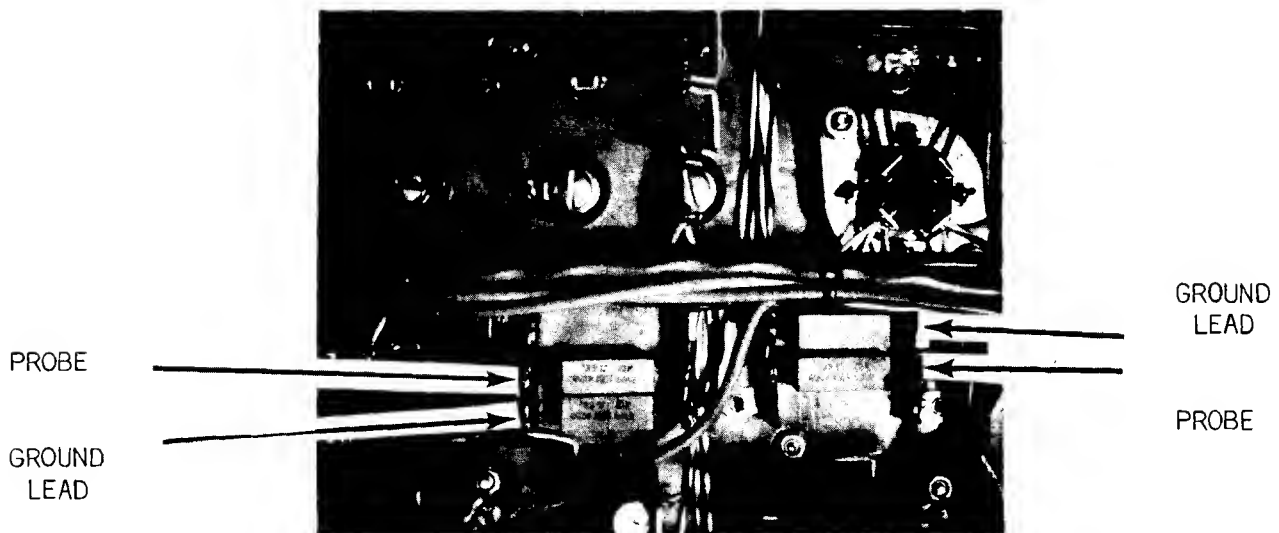

McIntosh

Page -4-

- b) If the serial number is 21H00 or above, connect the VTVM as shown:

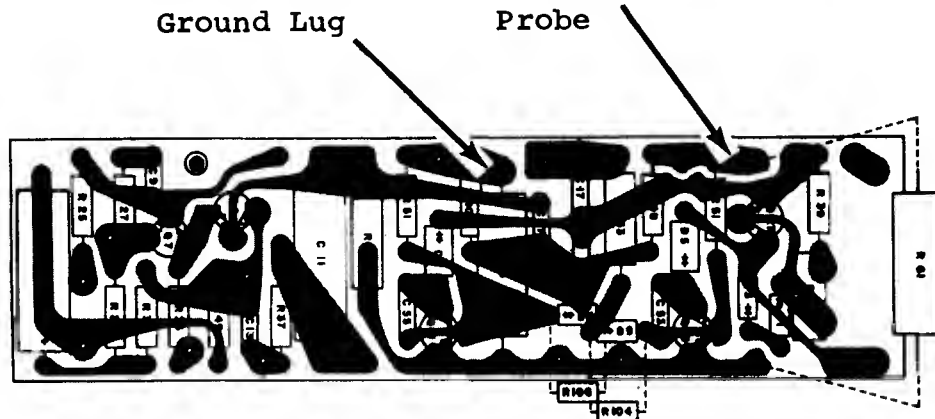

POWER OUTPUT PRINTED CIRCUIT BOARD

3. If there is trouble in one channel, you will not see the indication on the VTVM described in point 1. Stop right there. There are basically three possibilities of incorrect indication. The VTVM needle may not move at all, it may continue to swing positive, or it may continue to swing negative.
4. Regardless of the incorrect indication, it is usually not difficult to find the source of trouble. Turn the line voltage completely off. Discharge the large filter capacitors. Do not discharge the capacitors by shorting them directly to the chassis. Because of the arcing that will occur, the chassis will be marred. The proper way to discharge these capacitors is with a resistor. Use a resistor of at least a two watt rating whose value is approximately 5 to 15 ohms. Hold it across each of the large filters. In this way the power supply will be safely discharged. Failure to discharge the power supply before working on the amplifier could cause several transistors to be destroyed.

McIntosh

Page -5-

5. After the power supply is discharged, check each transistor. This is done quite easily with the VTVM.
CAUTION: USE VTVM SUCH AS THE RCA SENIOR VOLTOHMYST. Do not use older 1,000 ohms per volt VOM. This type of instrument may destroy the transistor by introducing excessive current into the transistor. Set the VTVM to measure ohms; after the power supply is discharged, check each transistor. Set the VTVM to measure ohms; use the "R x 1" scale. Measure across each junction of the transistor. Measure from base to collector, base to emitter, emitter to collector, emitter to base, collector to emitter, and collector to base. Also measure from the case of the transistor to ground. In no case should there be a direct short. In most cases, only one channel of the amplifier will be defective. Therefore, until you become familiar with the readings to expect in each case, compare the defective channel with the good channel. Although a defective transistor will usually be indicated by a direct short, this is not always the case. It is possible for a difference of only 2 or 3 ohms to indicate a defective transistor. For example, if a transistor in the defective channel reads 12 ohms from one junction to another, and the similar transistor in the good channel reads 10 ohms, the transistor which reads 12 ohms is probably defective.
6. If the transistors all measure correct, check the power resistors at the emitter and collector of the output transistors. These will have a very low resistance of about .33 ohms to .56 ohms. You may find that one of these resistors has opened up.
7. Also check the bias potentiometer for continuity. Be certain that it has not opened up.
8. After replacing a defective part, always turn the amplifier on as described in point 1. Otherwise, you may damage more parts. For example, you may find a shorted output transistor. You will replace the transistor. If there are other defective parts, that you do not yet know about, and you turn the amplifier on directly, in all probability, you will damage the new transistor that you have just installed.

McIntosh

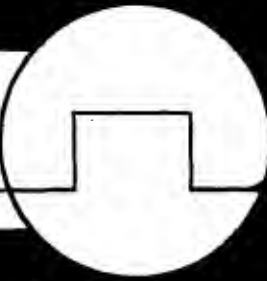

Page -6-

9. Before working on a solid state amplifier, ALWAYS discharge the power supply as described in point 4. If you do not do so, and then begin probing with a soldering aid, VTVM probe, or what have you, in all probability you will damage some transistors when you accidentally short from certain places to ground!

10. If the difficulty is not located as described in points 5, 6, and 7 you may turn the amplifier partially on. Bring the line voltage up to 25 or 30 volts. This will be enough voltage to enable you to signal-trace, compare voltages between the good channel and the defective one, etc., without damaging any components.

McIntosh

This bulletin deals with RF suppression in the MA5100. The modifications described will increase the RF suppression capabilities of the amplifier.

If a "pop" is heard through the speakers when the amplifier is turned on, check to see if the on/off switch has a metal shield over it. Also, see if the wires going to the on/off switch are exposed or shielded. For maximum suppression of this "popping", the on/off switch and the wires to the switch should be shielded. If they are not, order the following parts:

1 Shield	McIntosh Part No. 001-474
1 Shielded Cable	McIntosh Part No. 170-025

These parts are available as a kit. Order McIntosh kit number 9043-696.

In a few installations in homes, there have been reports of "clicks" or "popping sounds" when appliances are turned on, refrigerators start, etc. Also, in homes situated near powerful radio stations, there have been a few reports of hearing the radio station in the phono mode. The following modification will eliminate these possibilities.

Two capacitors and one resistor are added in each channel of the MA5100. These parts are placed on the parts card on top of the chassis. They are in the low level input circuits.

Refer to the following diagram:

1. Add a 6.8 capacitor from base to collector of Q1. Add a similar capacitor to Q2.
2. Add a 39pf capacitor from base to emitter of Q1. Do likewise at Q2.
3. On the printed circuit board you will find a yellow wire (for the left channel) and a yellow/white wire (for the right channel). One end of these wires connects to the input selector switch. The other one connects to the printed circuit board near Q1 (for left channel) and Q2 (for right channel). Remove the wires from the printed circuit board.

McIntosh

In their place install a 4.7K 1/4 watt resistor in each channel. The resistor should stand vertically on the board. Solder the end of the wire that you removed from the board to the other end of the 4.7K resistor.

Parts Needed

2 -- 6.8pf capacitors	McIntosh part number 061-008
2 -- 39pf capacitors	McIntosh part number 061-017
2 -- 4.7K 1/4 watt resistors	McIntosh part number 136-298

Be sure to use the exact parts as specified.

A kit is available from the McIntosh Laboratory Service Department. Its part number is 9043-643.

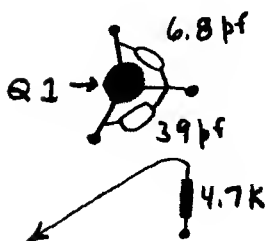

Yellow wire to selector switch

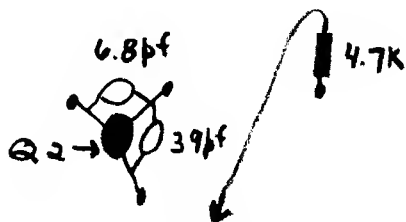

Yellow/White wire to selector switch

NOTE: Keep all resistor and capacitor leads as short as possible. Solder the capacitor leads directly to the "legs" of the transistors.

