

# McIntosh

## MR 78

FM TUNER



## SERVICE INFORMATION

FROM SERIAL NO. AD1001 TO AD5164

McINTOSH LABORATORY INC. 2 CHAMBERS STREET BINGHAMTON, NEW YORK

MR 78

## ELECTRICAL SPECIFICATIONS

## SENSITIVITY

2 $\mu$ V for better than 35dB quieting. 2.5 $\mu$ V IHF usable sensitivity  
Max., 1.9 $\mu$ V typical.

## SELECTIVITY IHF

	<u>ADJECENT CHANNEL</u>	<u>ALTERNATE CHANNEL</u>
Normal	7dB	55dB
Narrow	22dB	>90dB
Super-Narrow	55dB	>>90dB

## SIGNAL TO NOISE RATIO

Better than 75dB below 100% modulation.

## HARMONIC DISTORTION

Less than 0.2% mono or stereo at 100% modulation 20Hz to 18kHz.  
Typically less than 0.05% at 1kHz.

## FREQUENCY RESPONSE

$\pm$  1dB 20Hz to 18kHz with standard 75 $\mu$ S de-emphasis.

## CAPTURE RATIO

Better than 2.5dB IHF.

## SPURIOUS REJECTION

Greater than 100dB IHF.

## IMAGE REJECTION

Greater than 100dB 88 to 108MHz IHF.

## STEREO SEPARATION

Better than 40dB at 1kHz.

## SCA FILTER

50dB down from 67kHz to 74kHz; 275dB per octave slope.

## POWER REQUIREMENTS

120VAC, 50 - 60Hz, 35W.

(NORMAL SELECTIVITY UNLESS OTHERWISE STATED)

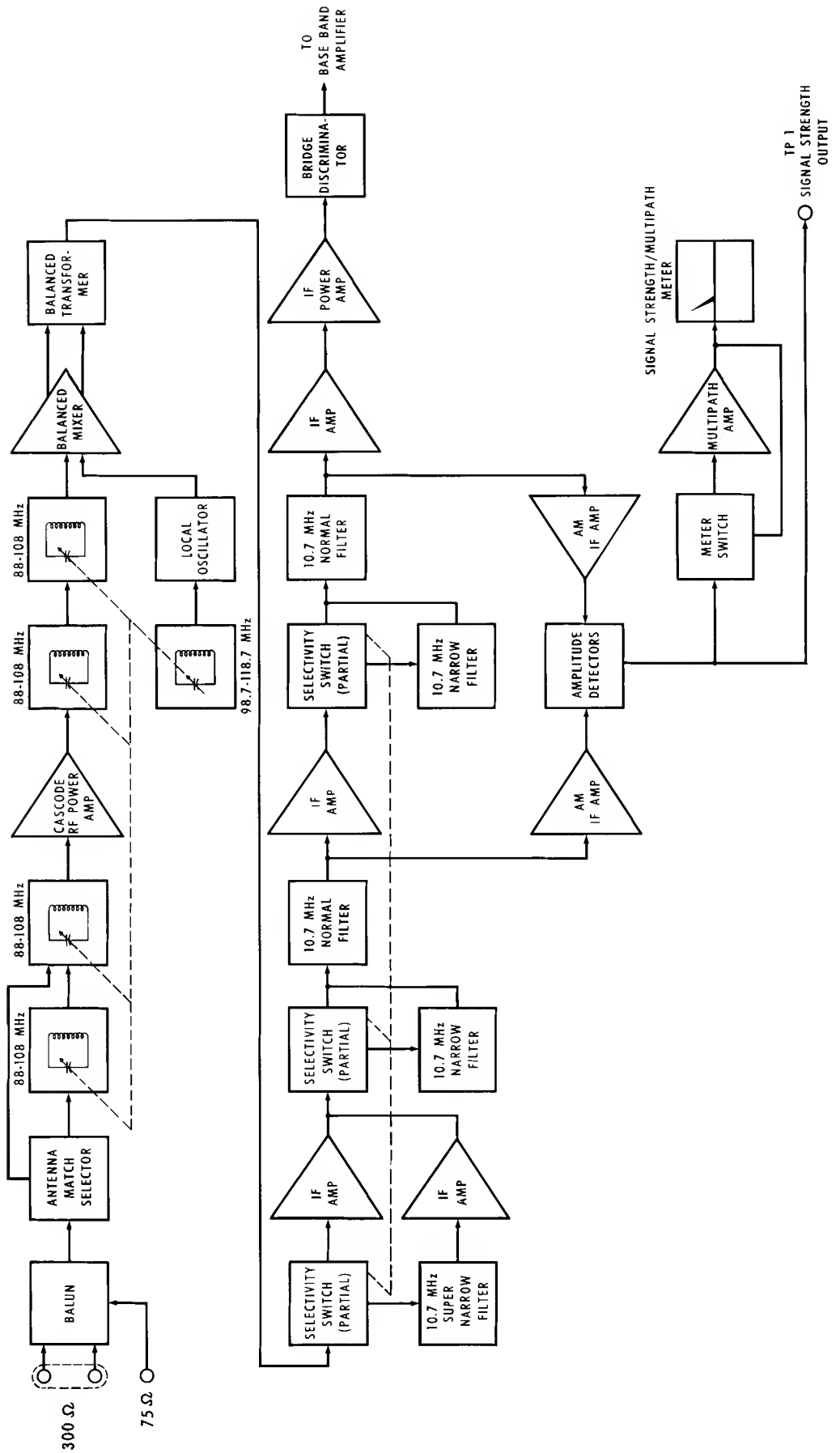

MR 78 BLOCK DIAGRAM

TP 1  
SIGNAL STRENGTH  
OUTPUT

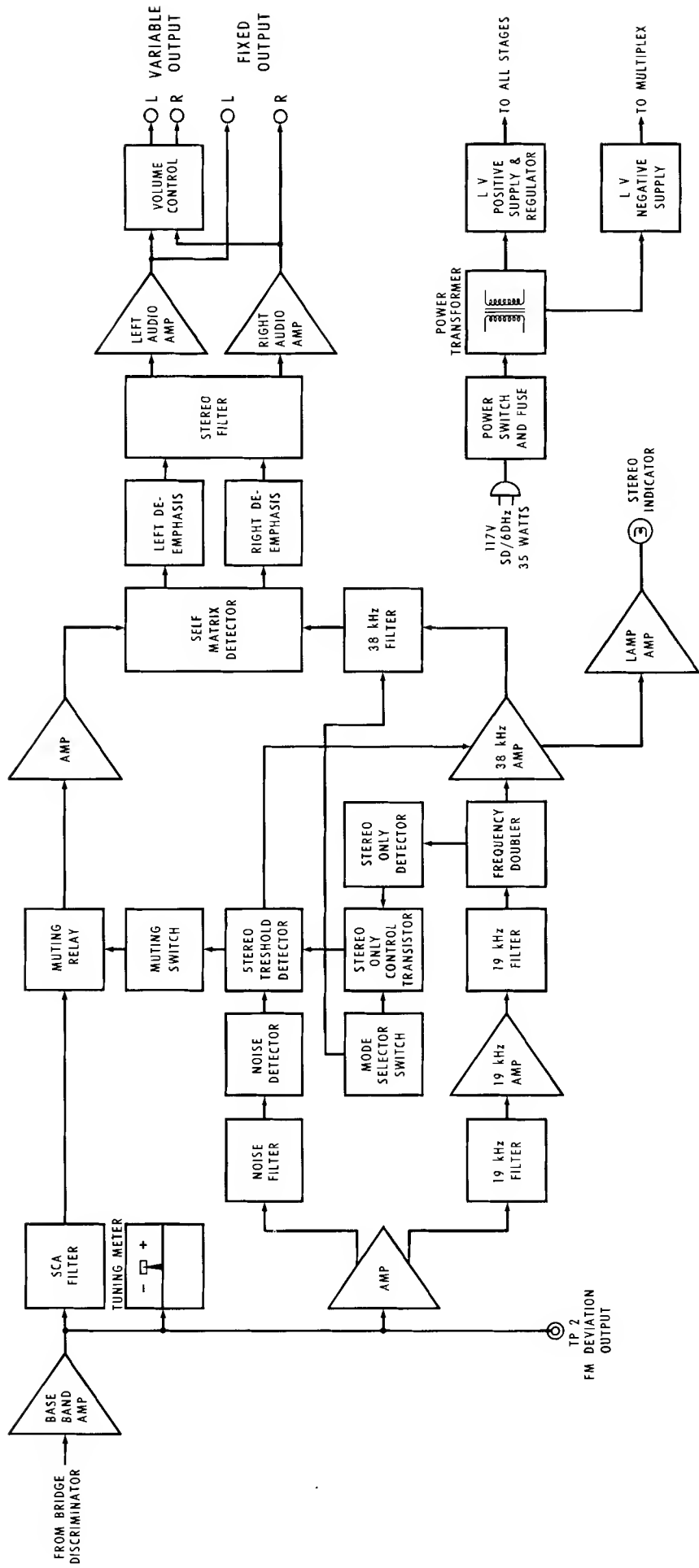

TP 2  
FM DEVIATION  
OUTPUT

## SCHEMATIC NOTES

1. Unless otherwise specified: Resistance values are in ohms, 1/4 watt, and 10% tolerance; Capacitance values smaller than 1 are in microfarads ( $\mu\text{F}$ ); capacitance values greater than 1 are in picofarads (pF); inductors are in microhenries ( $\mu\text{H}$ ).
2. Printed circuit board components are outlined on the schematics by dotted lines. The circled numbers around the dotted lines correspond to the numbers on the PC Board layouts.
3. The heavy lines on the schematics denote the primary signal path.
4. The terminal numbering of rotary switches is for reference only.
5. All voltages indicated on the schematics are measured under the following conditions:
  - a. Use of an 11 megohm input impedance VTVM.
  - b. All voltages  $\pm 10\%$  with respect to chassis ground.
  - c. No signal at input or antenna terminals.
  - d. AC input at 120 volts, 50/60 Hz.
  - e. Front panel controls at:
 

Tuning indicator	100MHz (no signal)	Muting	Out
Volume	Fully CW	Mode	Auto
Selectivity	Normal	Meter	Sig. Strength
Filter	Out	Panel Lights	Bright
6. In units with Serial No's. below AD1501 R612 is 3.3k and R613 is 150k.
7. In units with Serial No's. below AD1508 C602 and C603 are .01 $\mu\text{F}$ .
8. In units with Serial No's below AD4878 C331 and C334 are .0033.
9. In units with Serial No's below AD5014 C26 is 5pF, C27 is 9pF and C25 is 0.5-3pF.
10. In units with Serial No's below AD5014 R15 and C34 are not used. In the power supply section D508, R512, C508 and C509 are not used.

**POINTER DRIVE**

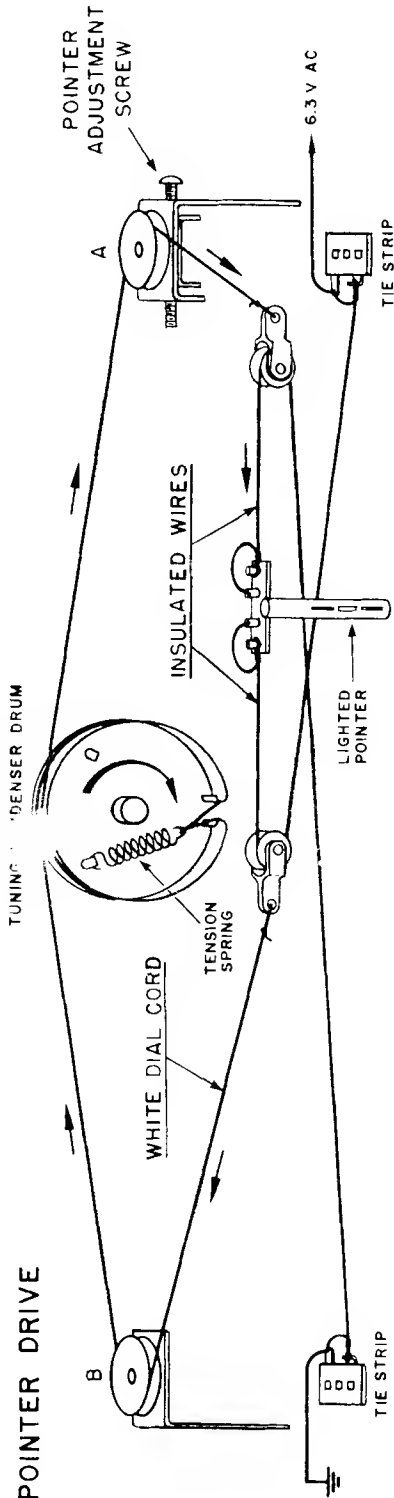

Step 1 Before stringing unit, turn pointer adjustment screw until pulley "A" is in the center of its travel.

Step 2 String unit as shown.

Step 3 After stringing unit, turn tuning shaft until pointer is as far to the left as it will go. Turn the pointer adjustment screw until the pointer coincides with the zero bar of the logging scale.

Step 4 Turn the tuning knob making the pointer move back and forth from one end of the dial scale to the other. Return pointer to the far left and, if necessary, re-adjust pointer position.

**TUNING CONDENSER DRIVE**

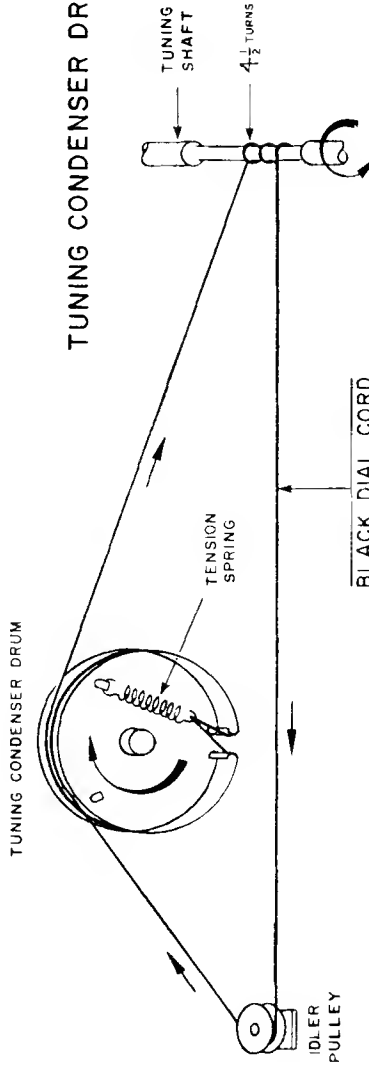

**DIAL CORD SEQUENCE**

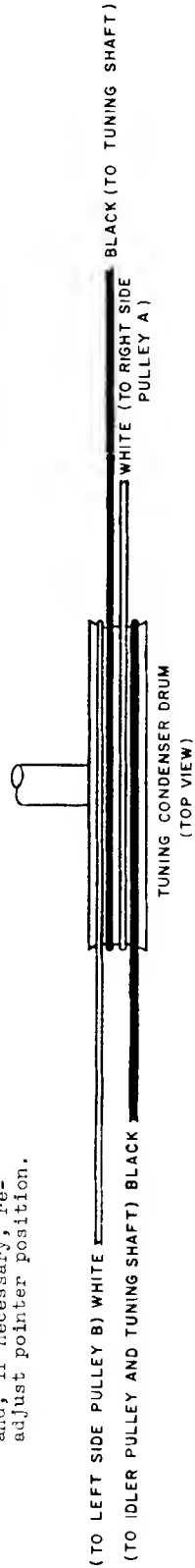

**POINTER DIAL STRINGING**

IF PC BOARD 044-352

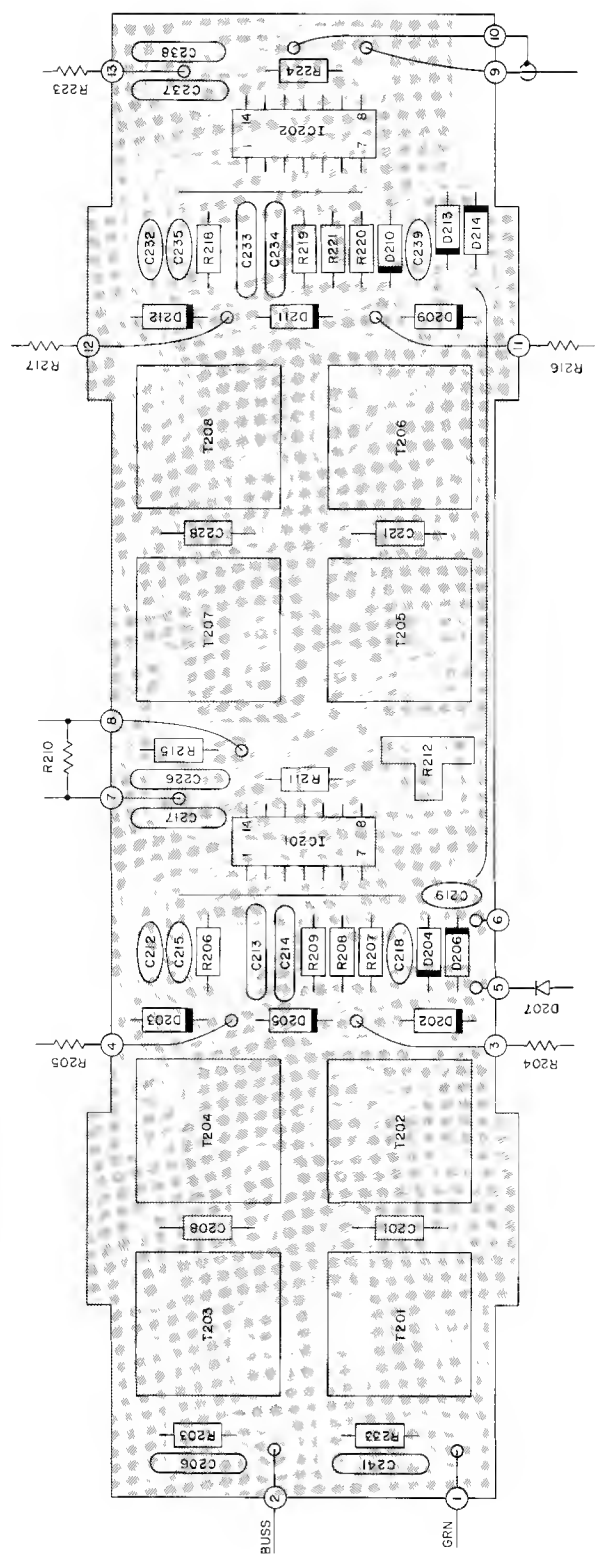

SELECTIVITY JCT. PC BOARD 044-565

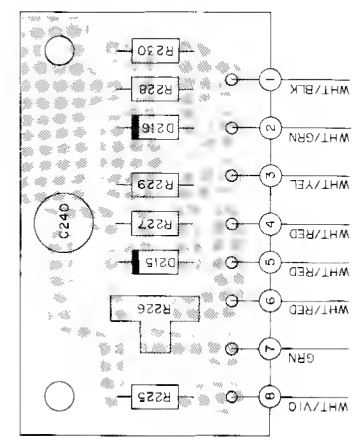

FM ANTENNA

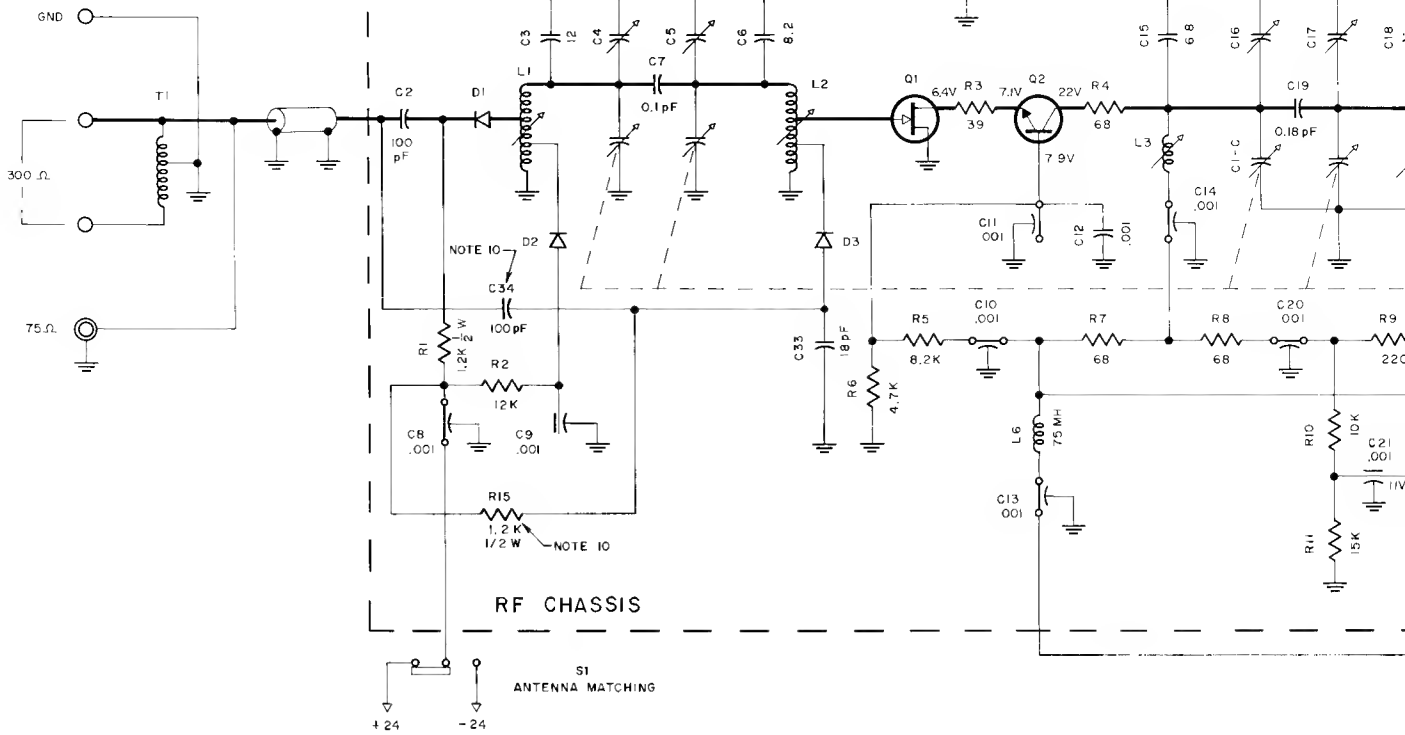

IF CHASSIS

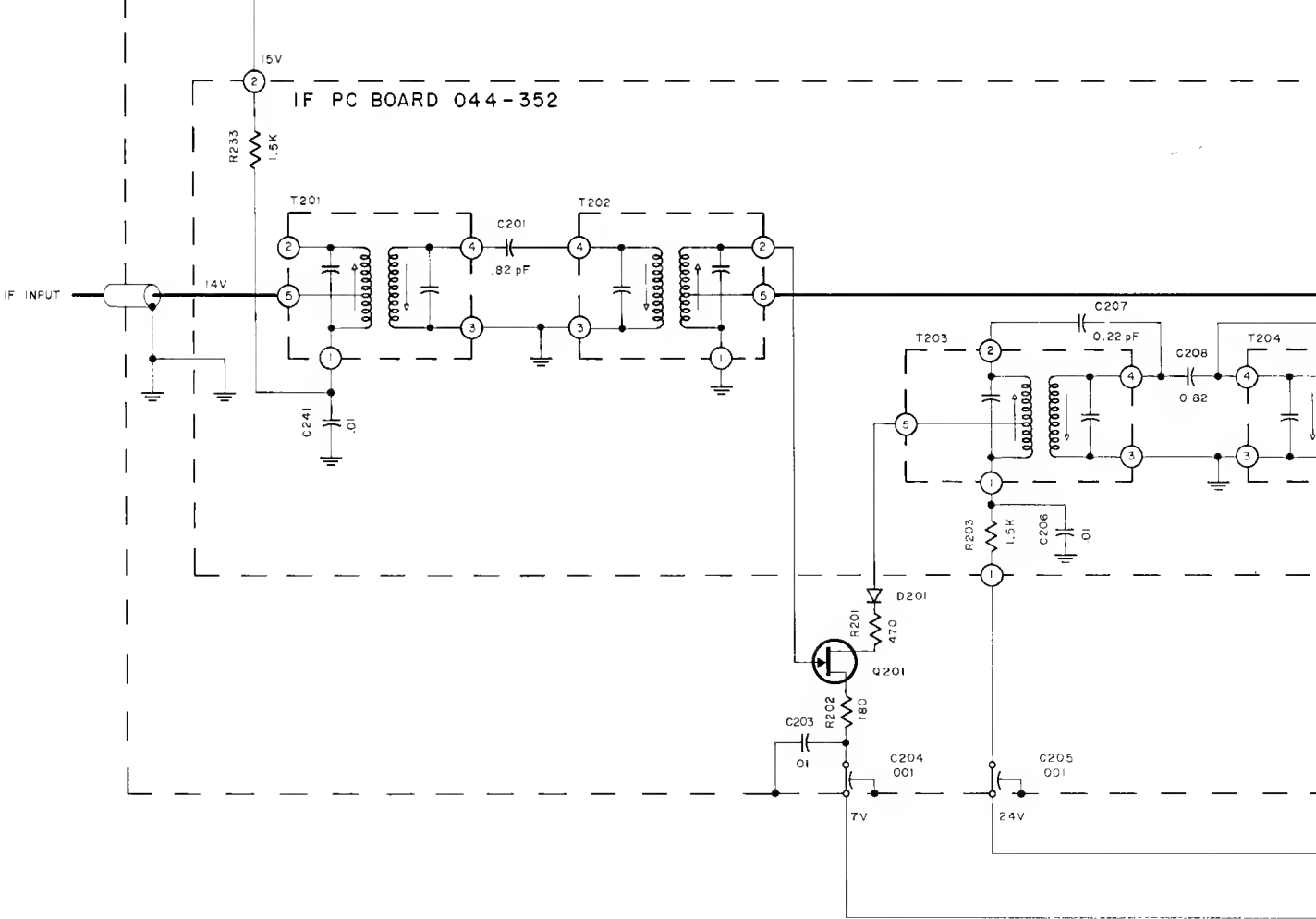



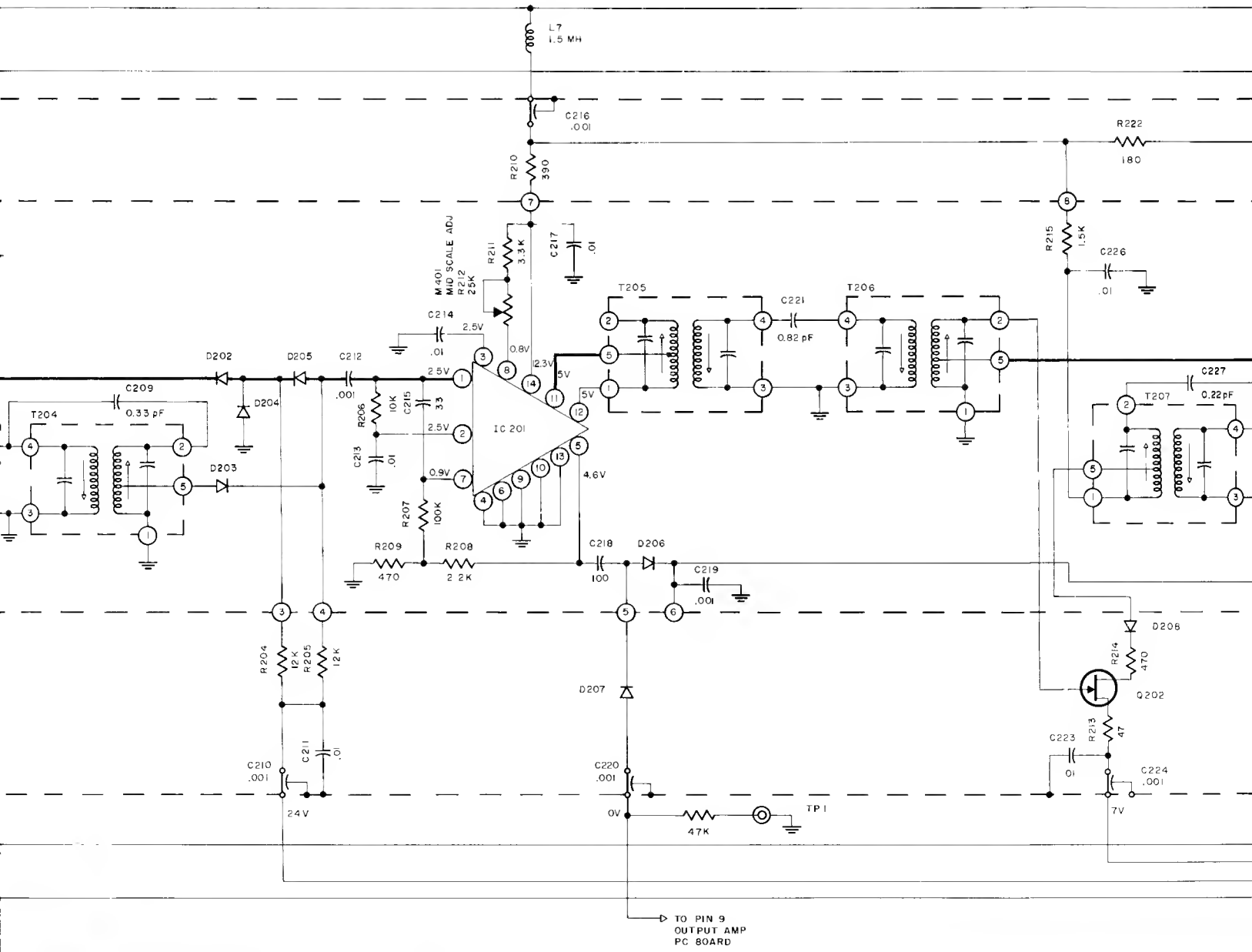
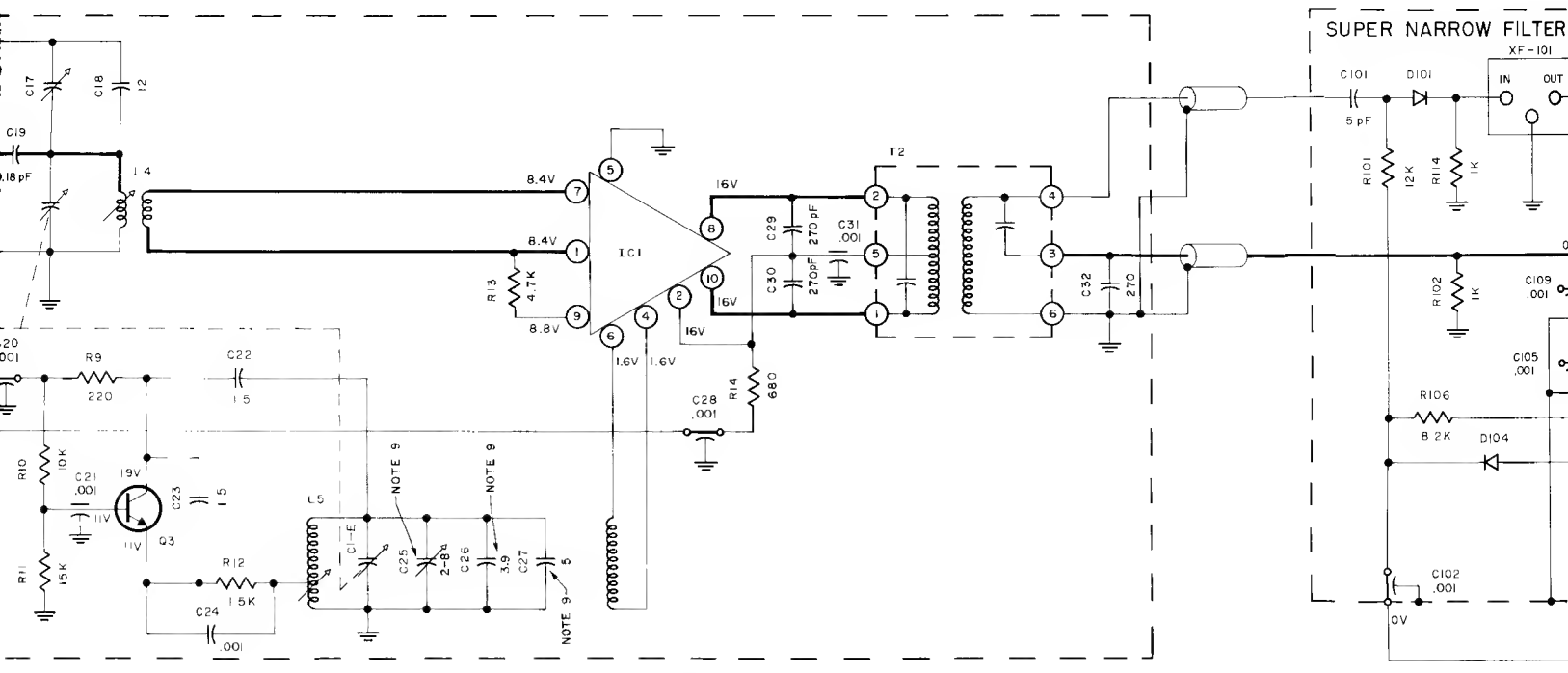

# SUPER NARROW FILTER ASSEMBLY

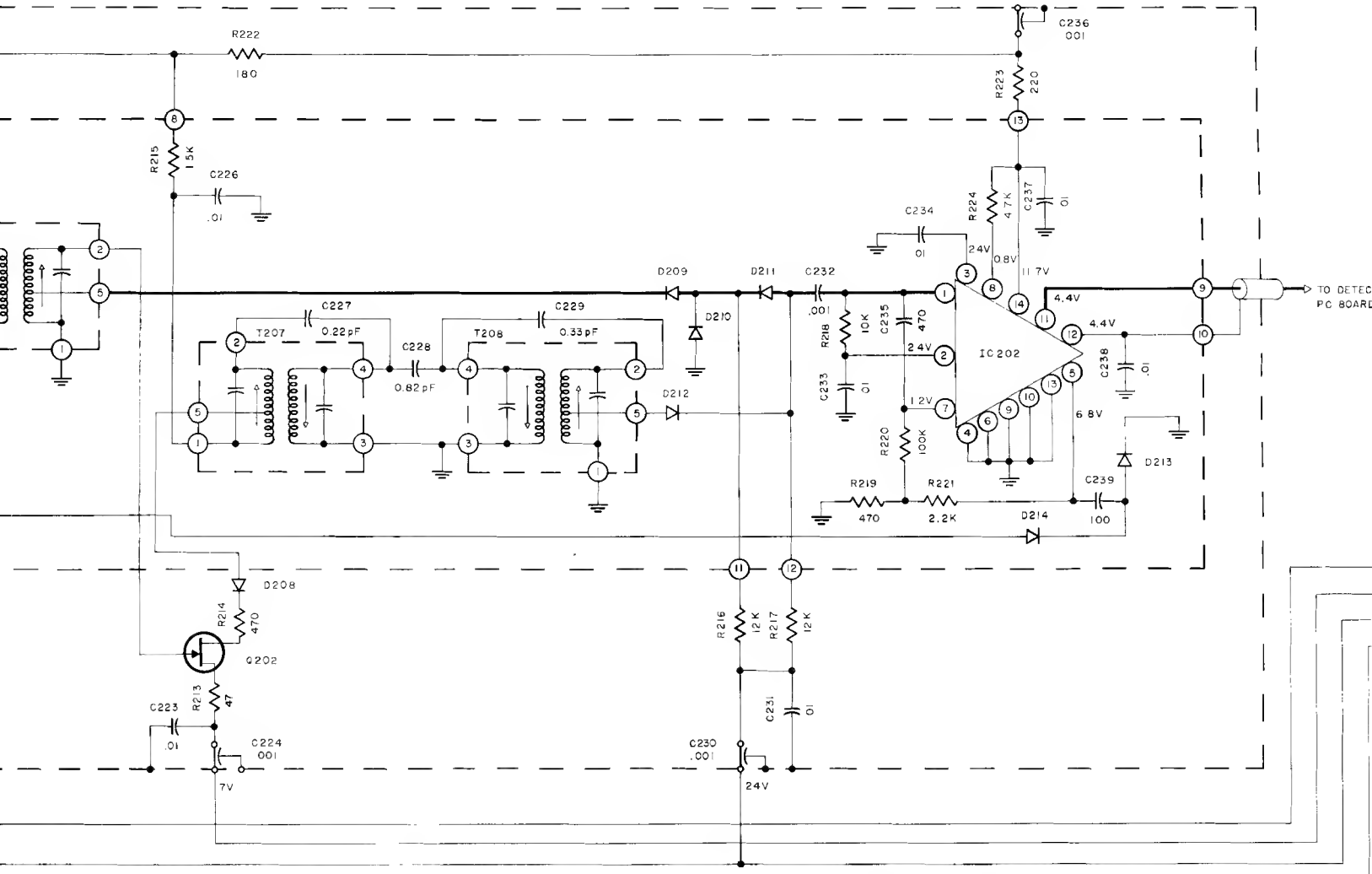
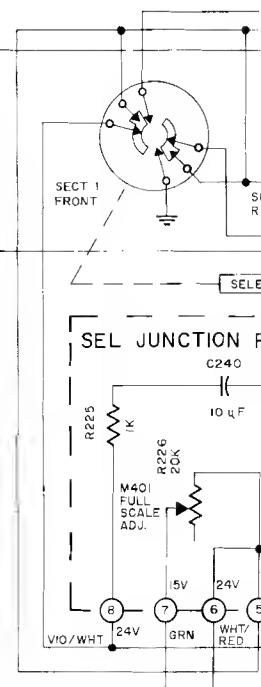
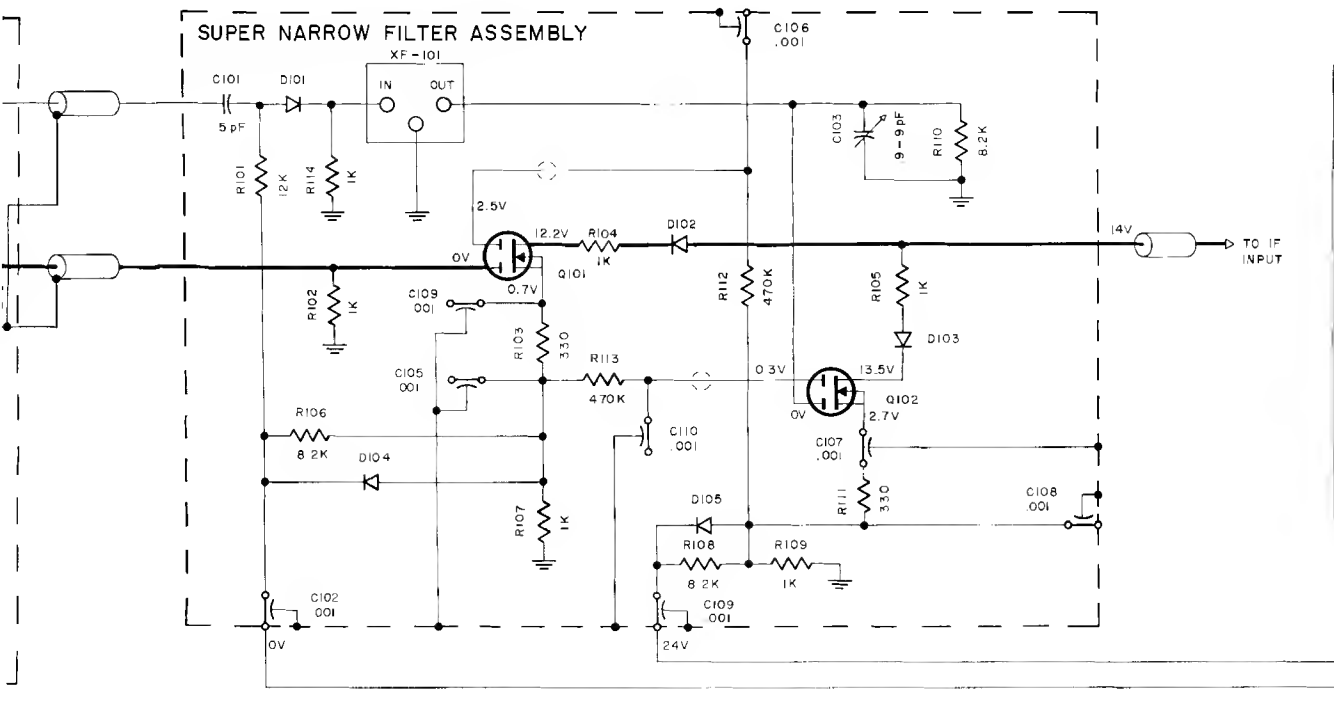

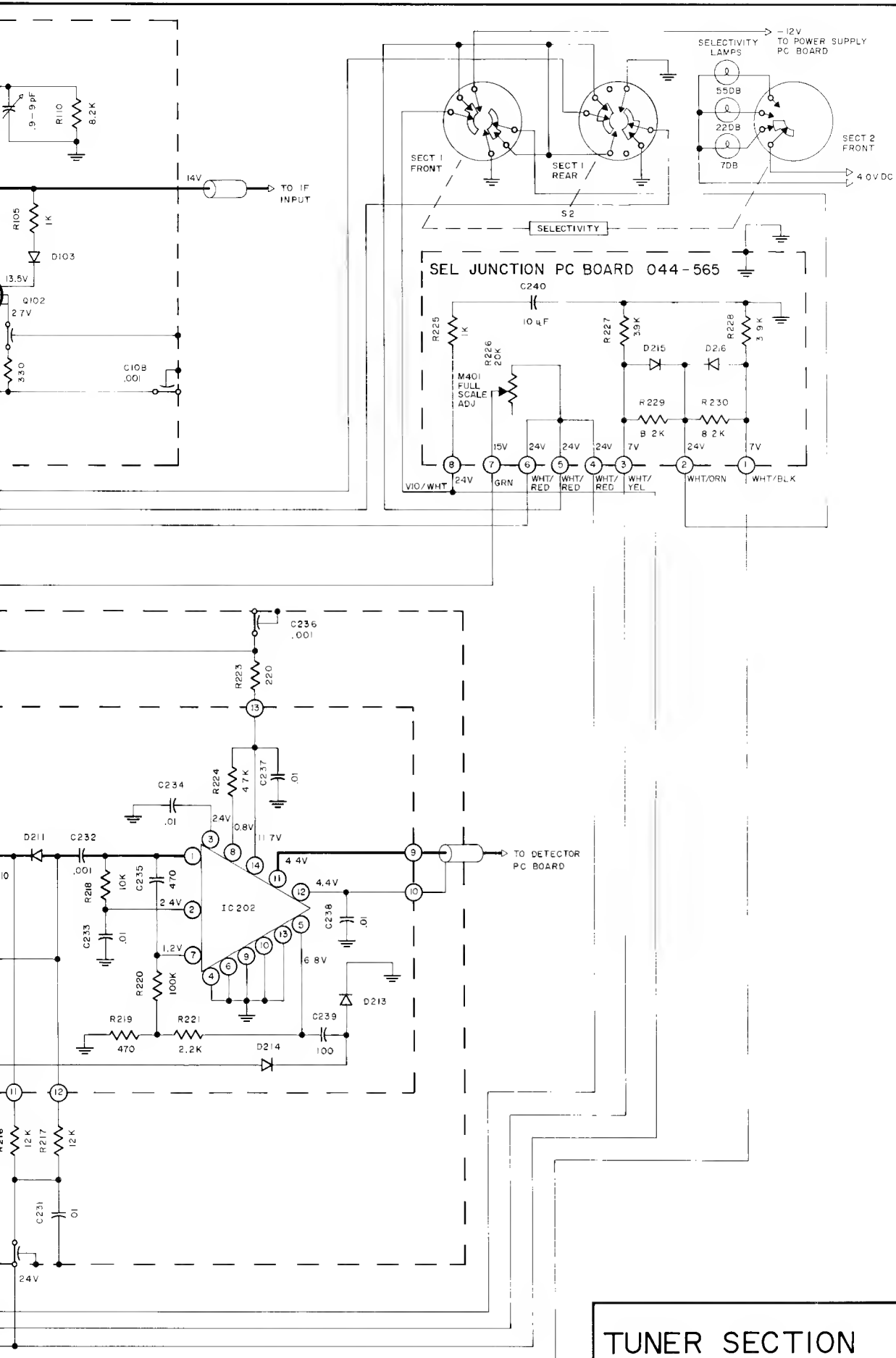

# TUNER SECTION

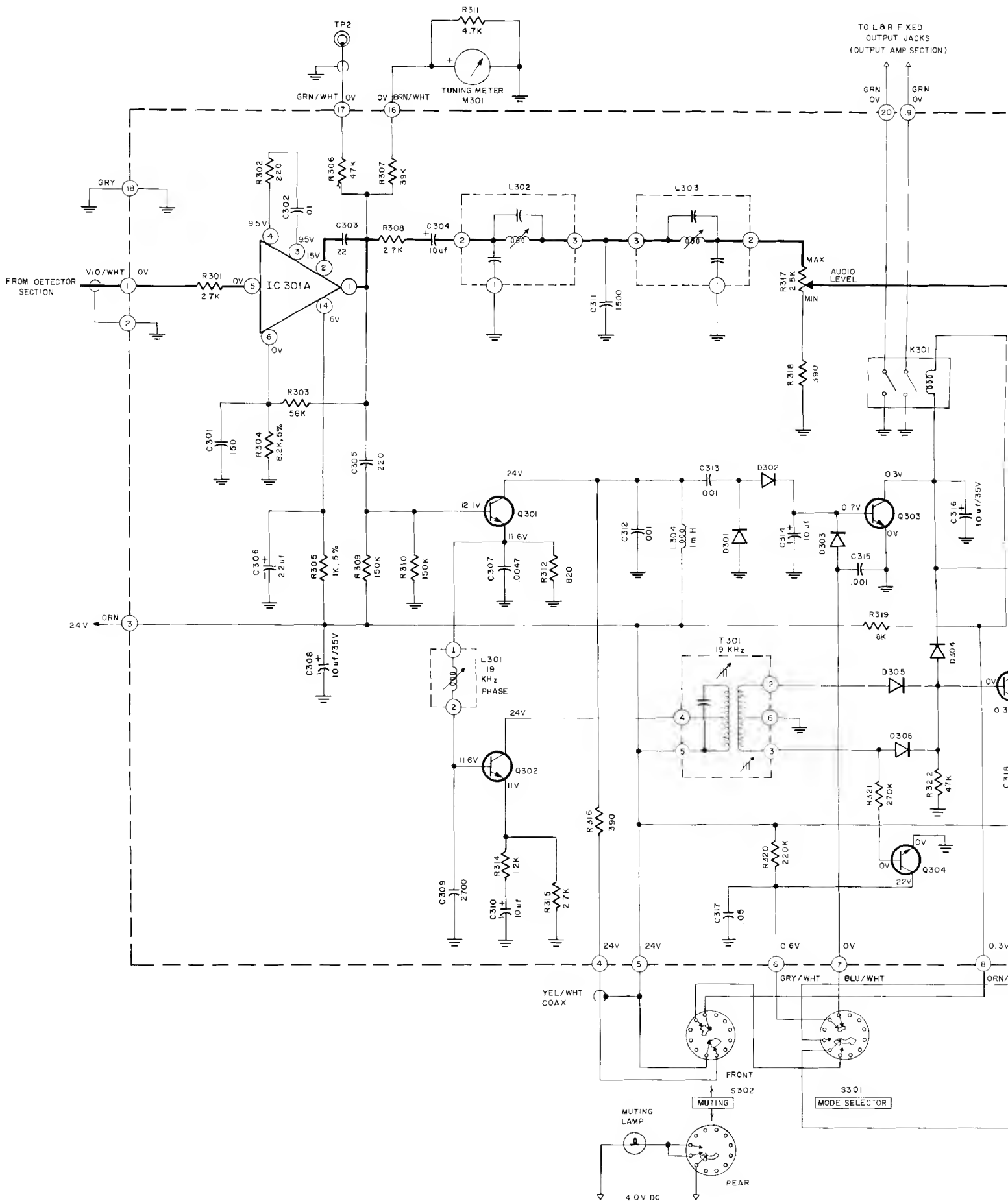

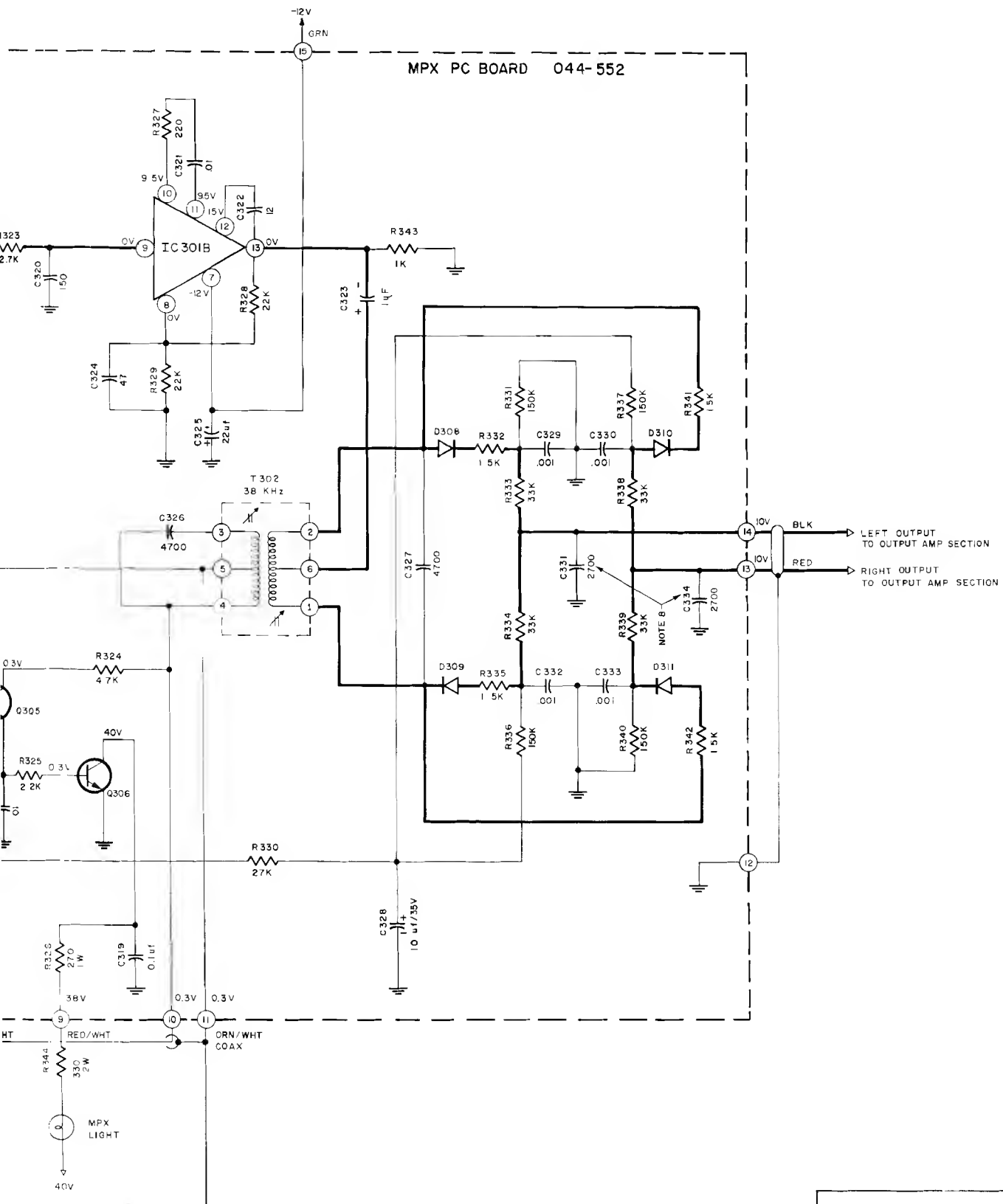

### MPX SECTION

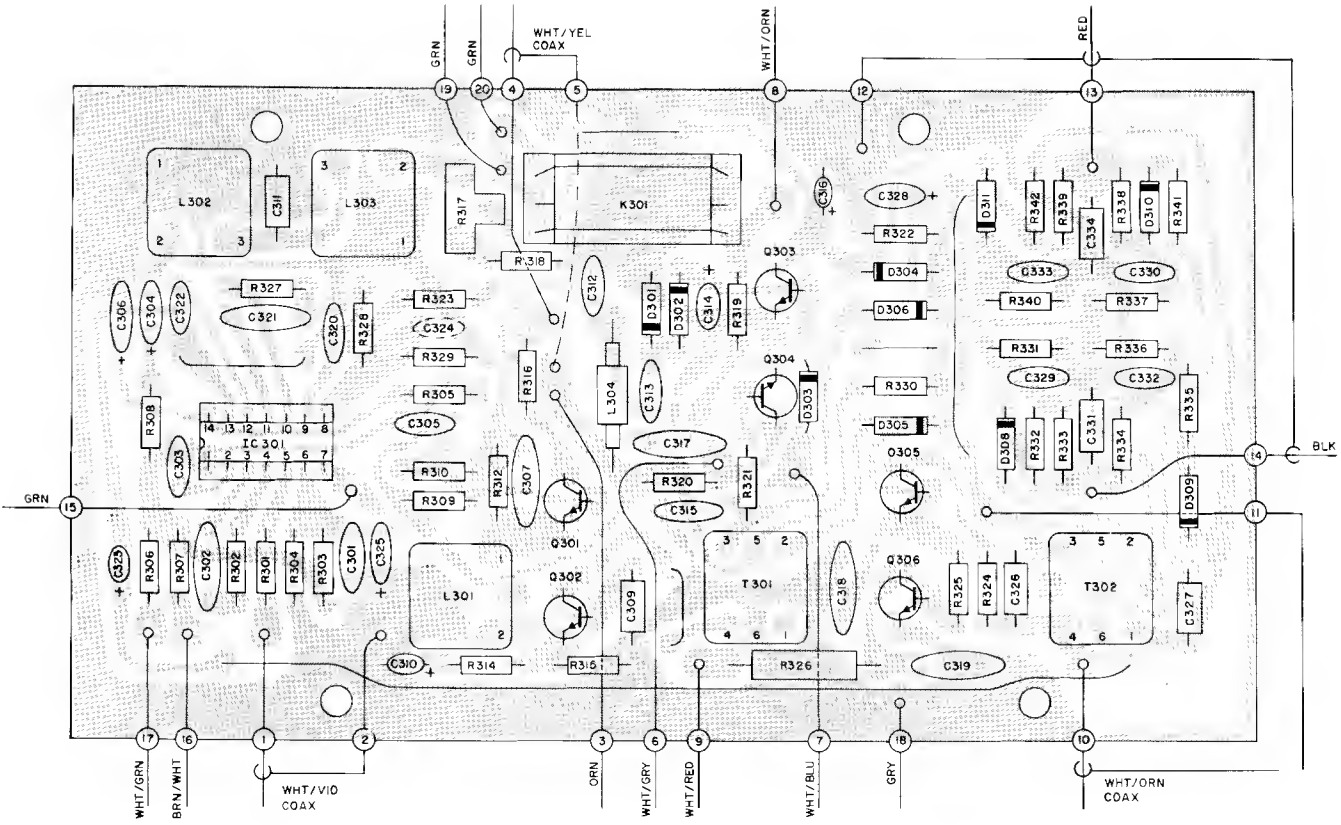

MPX PRINTED CIRCUIT BOARD 044-552

1 4/88 1

DETECTOR PC BOARD 044-351

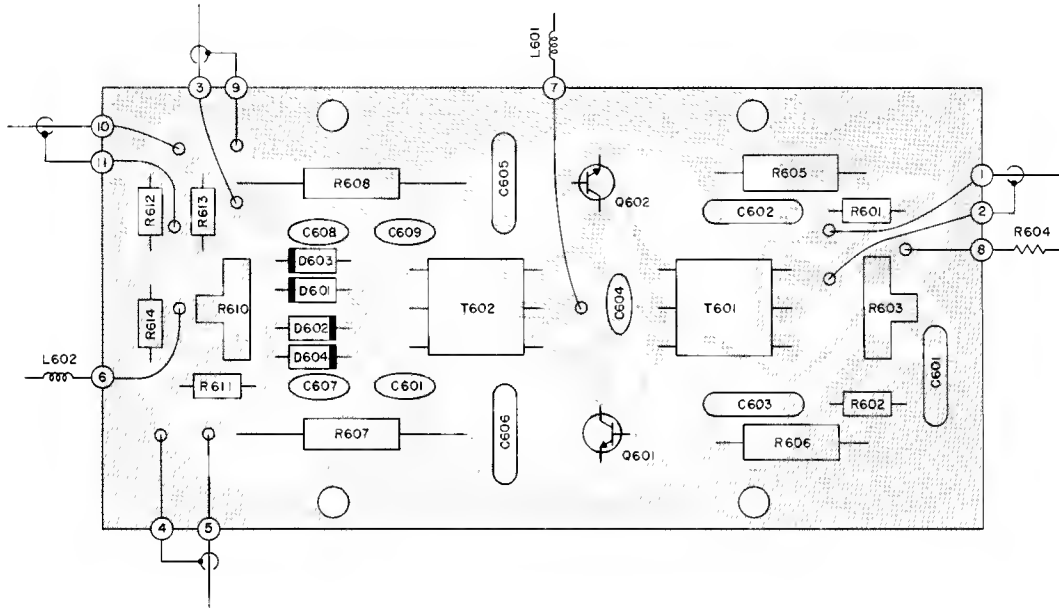

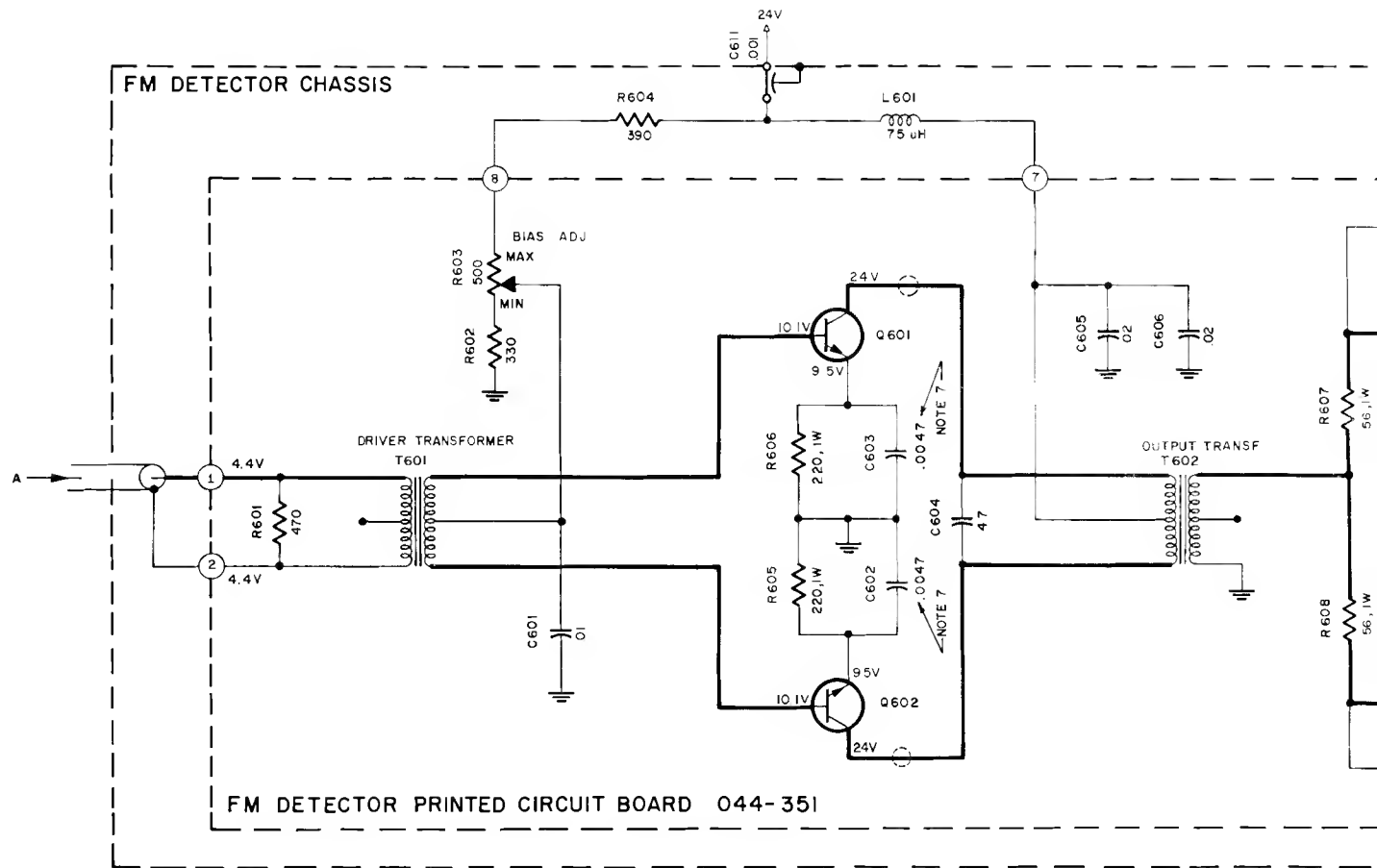

FM DETECTOR CHASSIS

FM DETECTOR PRINTED CIRCUIT BOARD 044-351



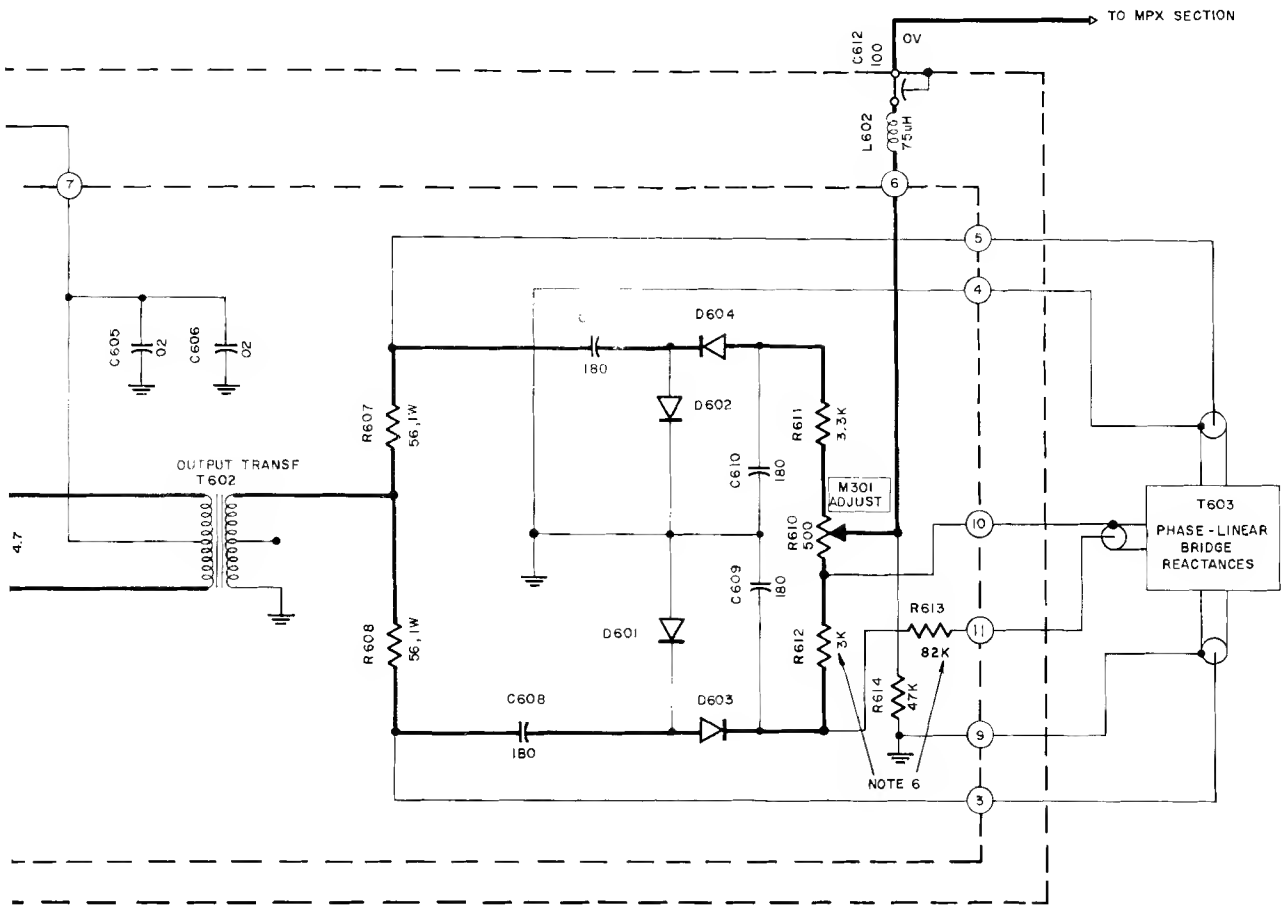

# DETECTOR SECTION

OUTPUT AMPLIFIER PC BOARD 044-349

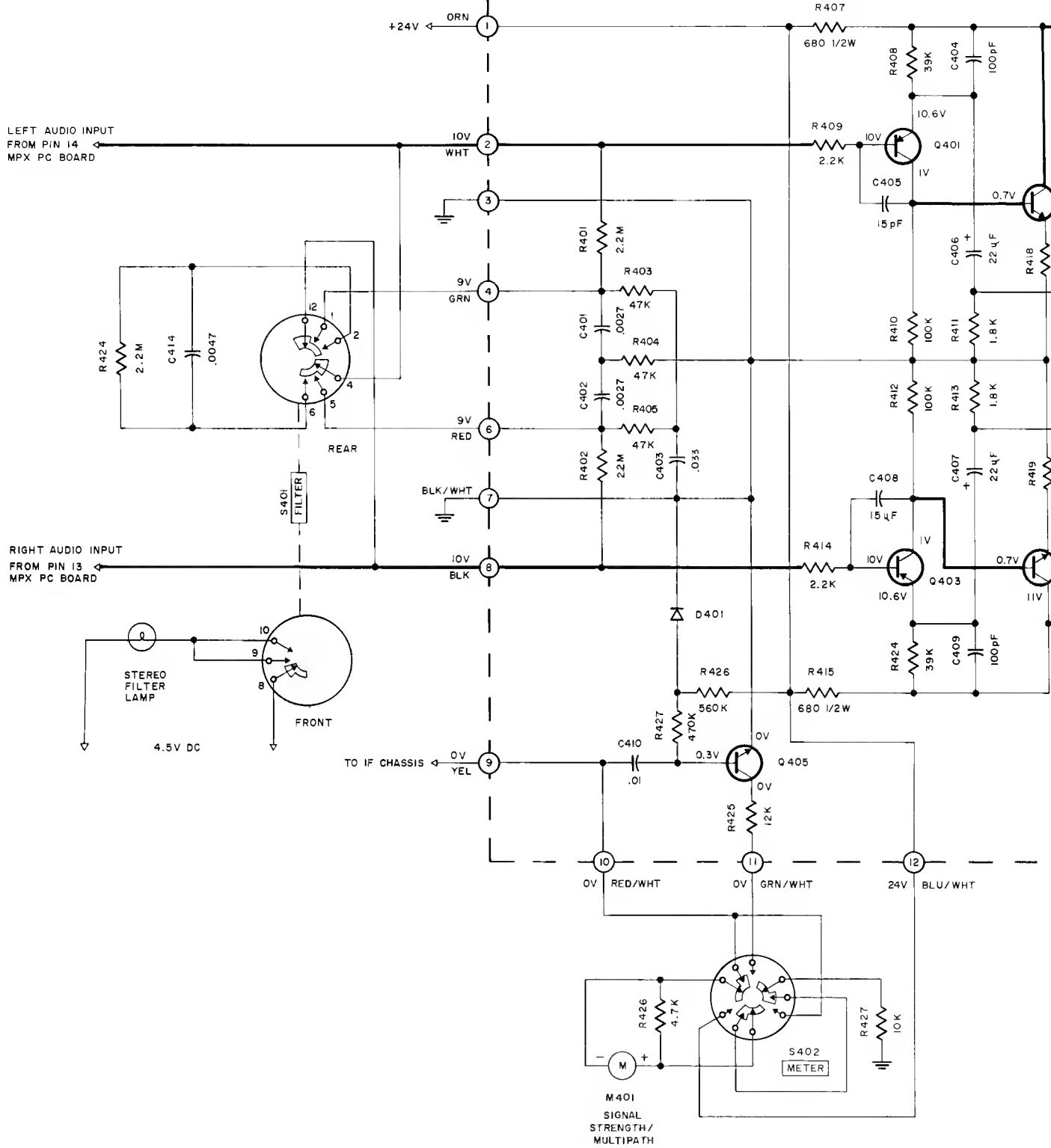

ARD 044-349

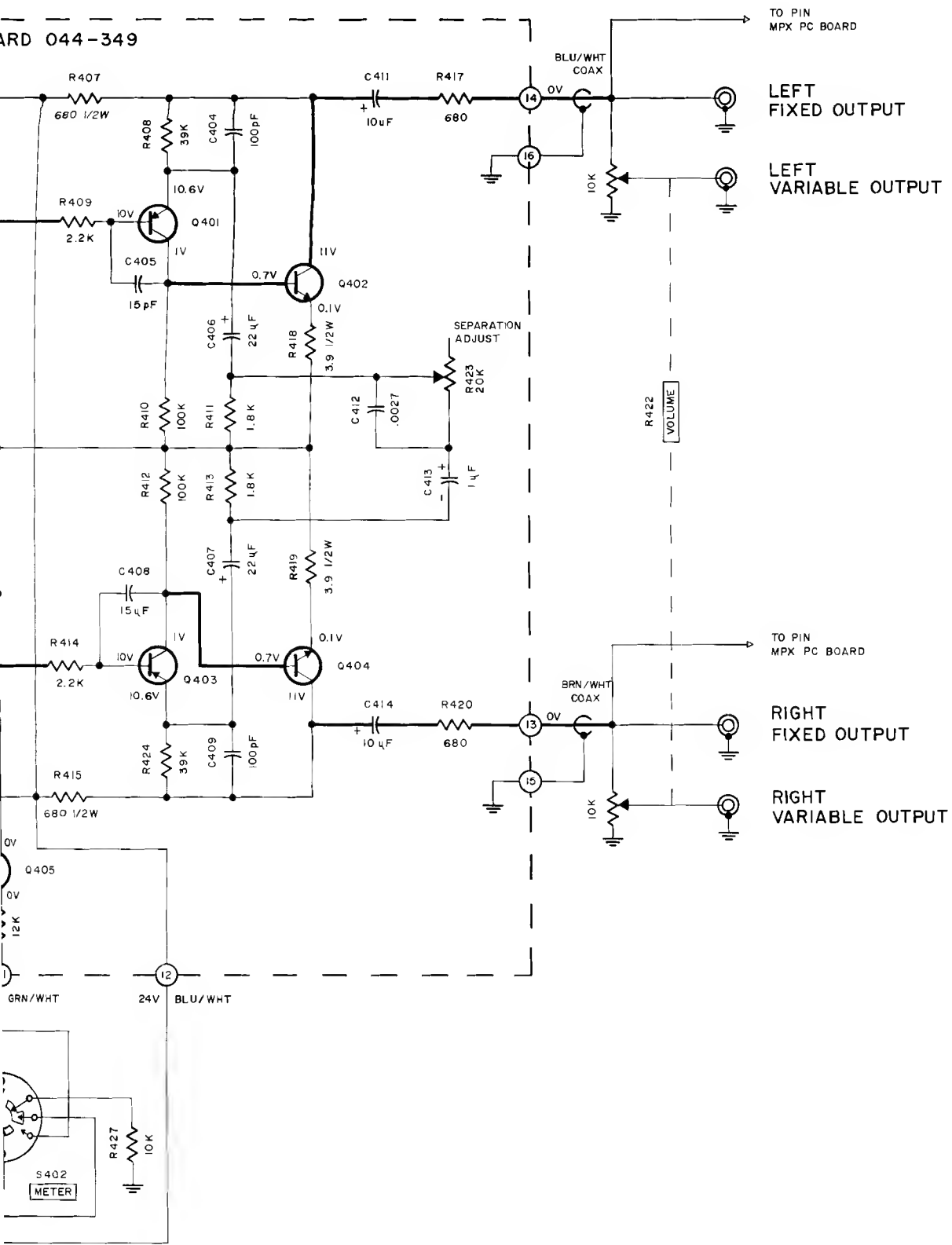

# OUTPUT AMP SECTION

OUTPUT AMP PC BOARD 044-349

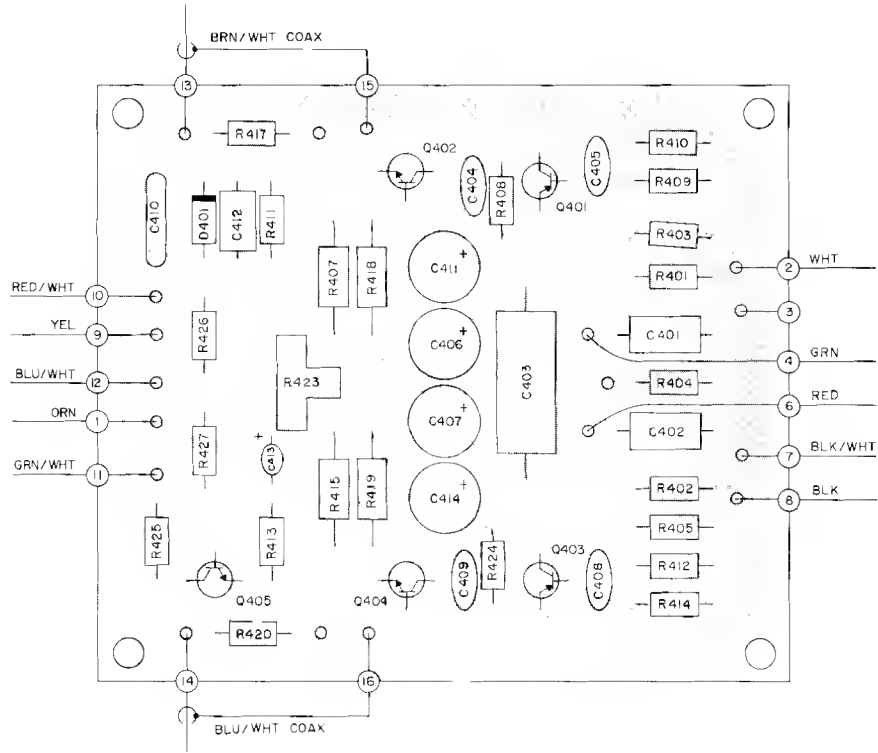

POWER SUPPLY PRINTED CIRCUIT BOARD 044-453

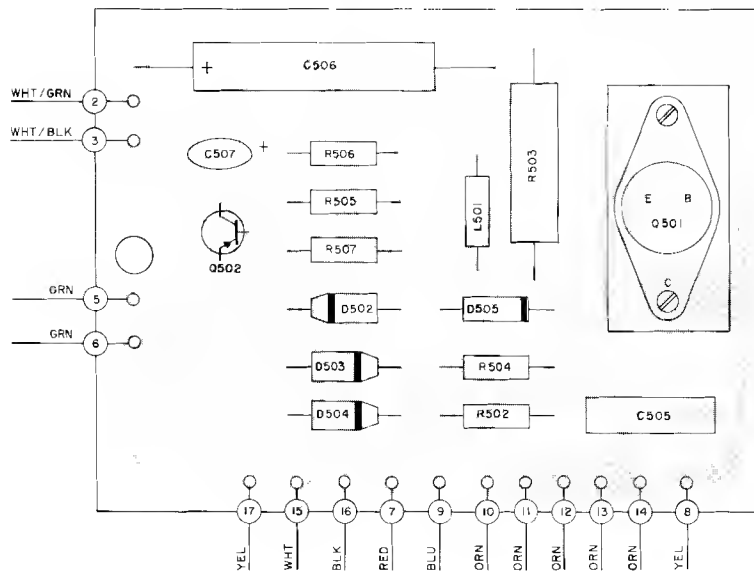

POWER SUPPLY PRINTED CIRCUIT BOARD 044-453

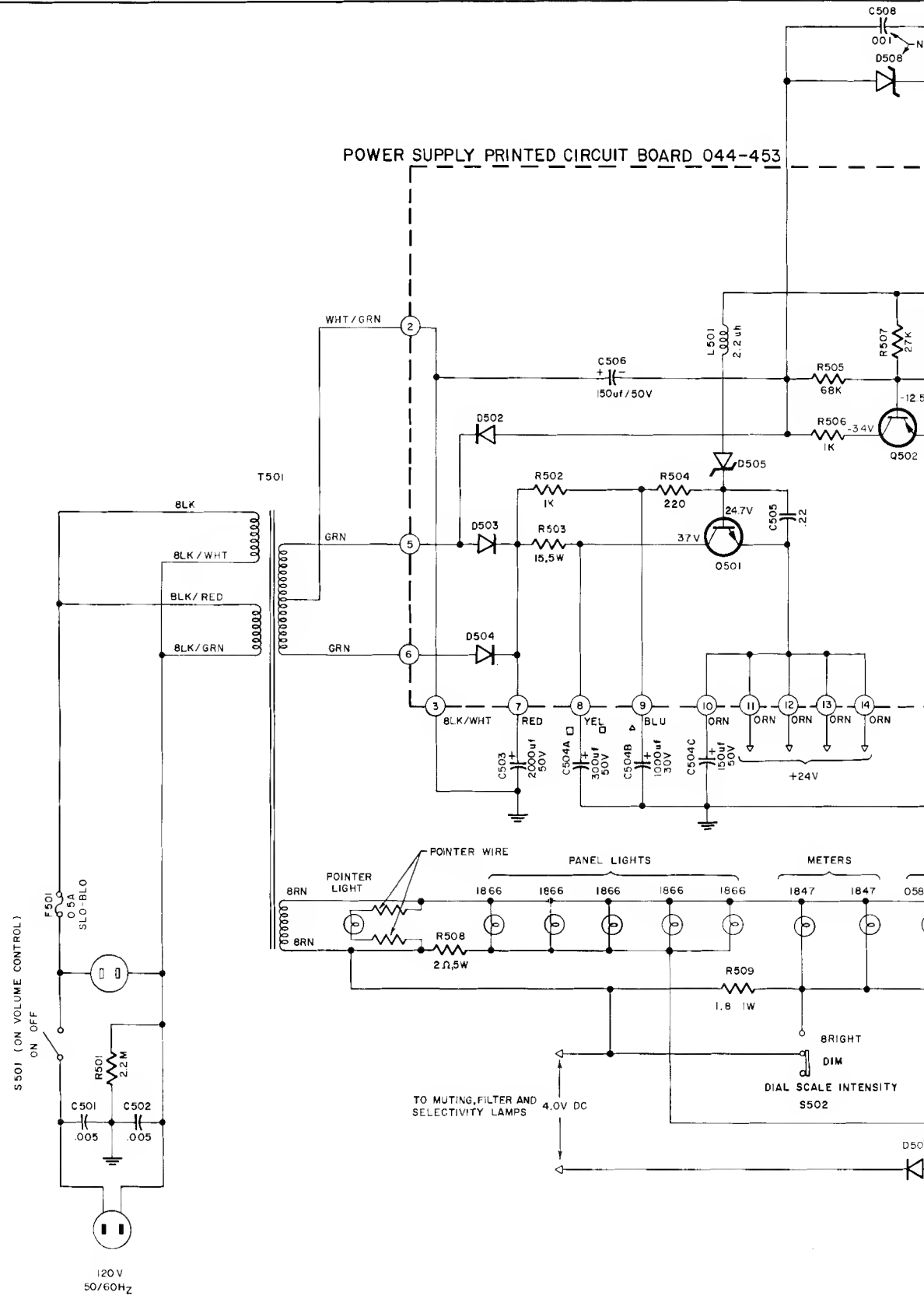

POWER  
SE  
MR78

POWER SUPPLY PRINTED CIRCUIT BOARD 044-453

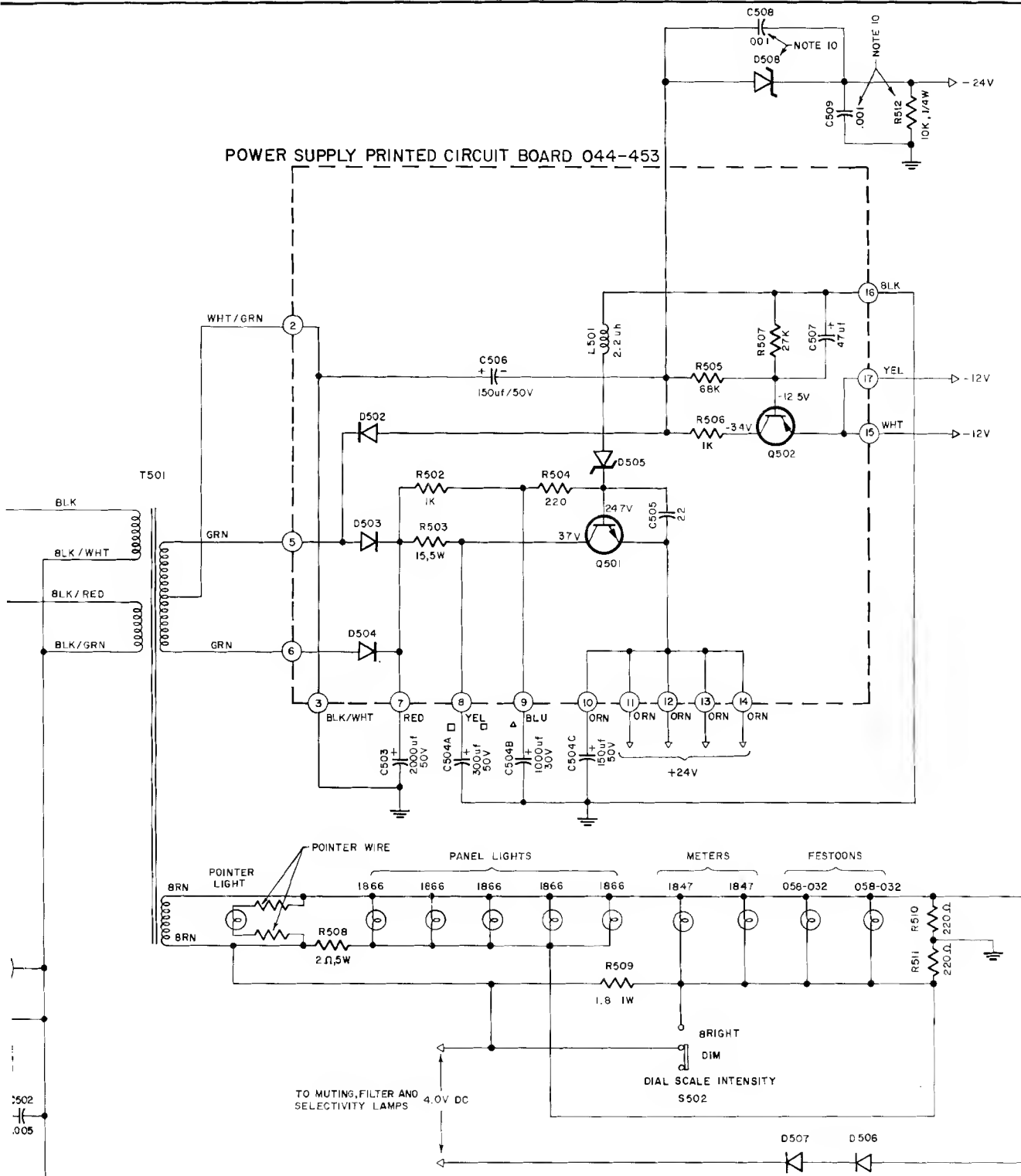

POWER SUPPLY SECTION

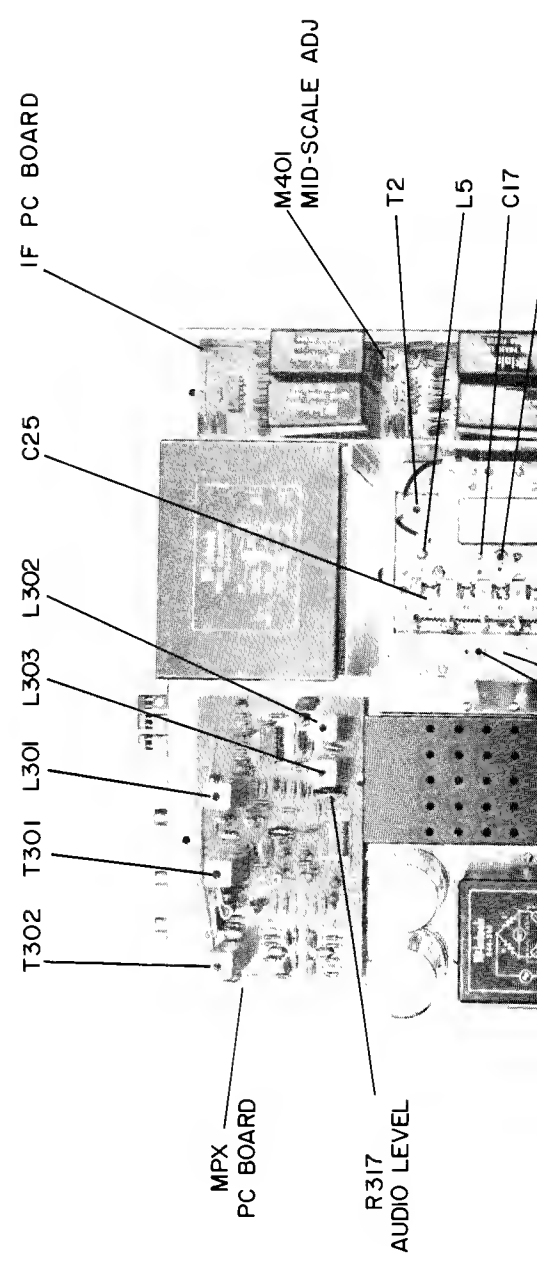
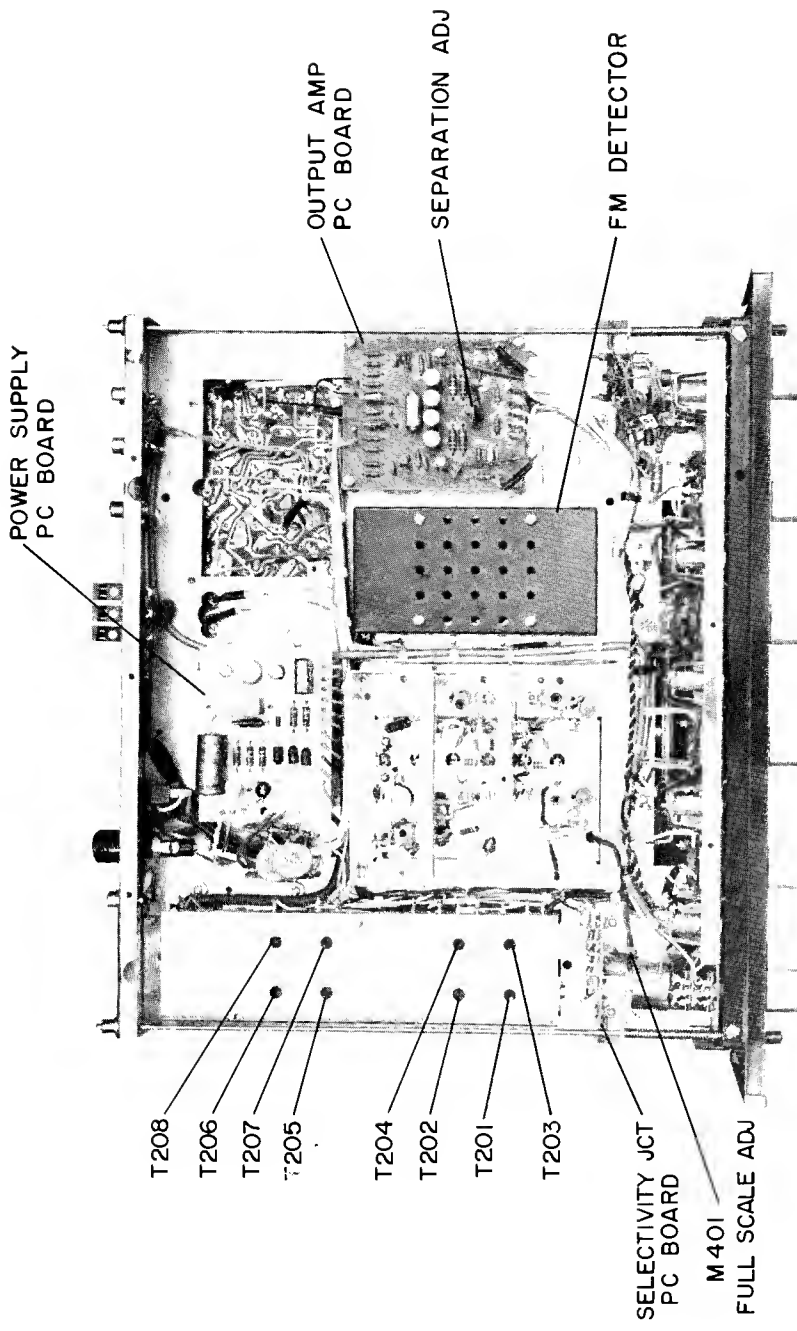

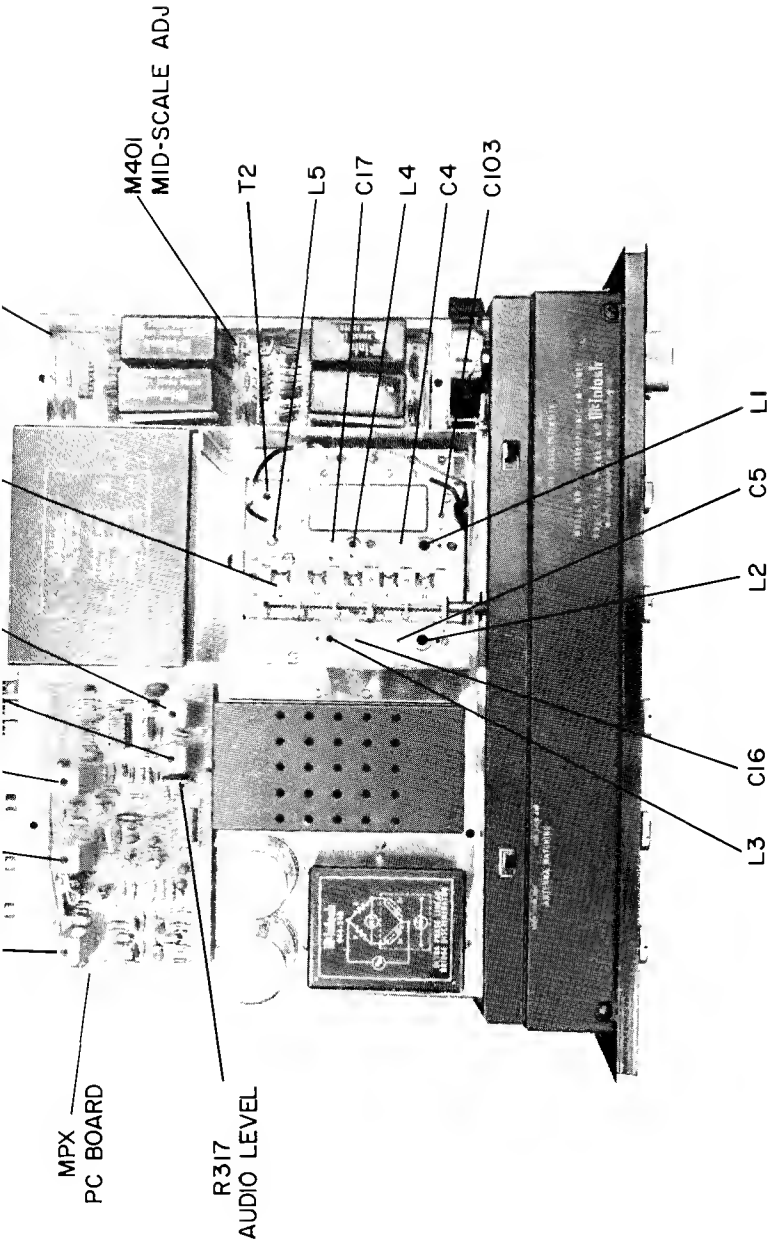

### MR 78 ALIGNMENT INSTRUCTIONS

All McIntosh tuners are carefully aligned and tested at the factory using the finest available test equipment. All McIntosh tuners will meet their published specifications when shipped from the factory.

After extensive operation, or servicing, it may be desirable to realign the tuner circuits for best performance. The charts below give complete information on the circuit realignment procedure for the MR 78.

The test equipment listed (or its equivalent) is necessary to properly align an MR 78. The accuracy of the alignment will be directly related to the accuracy and calibration of the test equipment used.

If the necessary test equipment is not available, alignment should not be attempted. For additional information, contact Customer Service Department, McIntosh Laboratory, Inc., 2 Chambers Street, Binghamton, New York 13903 (telephone 607-723-3512)

Alignment should be done in the following order: FM-MPX.

### FM ALIGNMENT

#### NOTES:

1. Begin alignment procedure with selectivity switch in normal position, stereo filter out, muting off, mode on mono, and meter on signal strength.
2. If tuner's RF circuits are known to be working, the IF alignment (Steps 1 - 4) may be performed using an 88 - 108 MHz generator (such as Sound Technology 1000A).

### TEST EQUIPMENT REQUIRED

1. FM Signal Generator (Measurement 188 or Sound Technology 1000A).
2. VTVM (RCA WV96C)
3. Multiplex Generator (Radiometer SMG1) or Sound Technology 1000A.
4. 10.7 MHz FM Sweep Generator (Kay 385 or equivalent). (Not needed if Measurement 275 IF converter is available.)
5. 10.7 MHz Generator (preferably crystal controlled).
6. Oscilloscope (Hewlett-Packard 120B or equivalent).
7. Harmonic Distortion Analyzer (Hewlett-Packard 333A or equivalent).
8. 10.7 MHz  $\pm 75$  kHz Sweep Marker Generator.



## MR 78 ALIGNMENT INSTRUCTIONS

All McIntosh tuners are carefully aligned and tested at the factory using the finest available test equipment. All McIntosh tuners will meet their published specifications when shipped from the factory.

After extensive operation, or servicing, it may be desirable to realign the tuner circuits for best performance. The charts below give complete information on the circuit realignment procedure for the MR 78.

The test equipment listed (or its equivalent) is necessary to properly align an MR 78. The accuracy of the alignment will be directly related to the accuracy and calibration of the test equipment used.

If the necessary test equipment is not available, alignment should not be attempted. For additional information, contact Customer Service Department, McIntosh Laboratory, Inc., 2 Chambers Street, Binghamton, New York 13903 (telephone 607-723-3512)

Alignment should be done in the following order: FM-MPX.

## FM ALIGNMENT

### NOTES:

1. Begin alignment procedure with selectivity switch in normal position, stereo filter out, muting off, mode on mono, and meter on signal strength.
2. If tuner's RF circuits are known to be working, the IF alignment (Steps 1 - 4) may be performed using an 88 - 108 MHz generator (such as Sound Technology 1000A).

## TEST EQUIPMENT REQUIRED

1. FM Signal Generator (Measurement 188 or Sound Technology 1000A).
2. VTVM (RCA WY96C)
3. Multiplex Generator (Radiometer SMGI) or Sound Technology 1000A.
4. 10.7 MHz FM Sweep Generator (Kay 385 or equivalent). (Not needed if Measurement 275 IF converter is available.)
5. 10.7 MHz Generator (preferably crystal controlled).
6. Oscilloscope (Hewlett-Packard 120B or equivalent).
7. Harmonic Distortion Analyzer (Hewlett-Packard 333A or equivalent).
8. 10.7 MHz  $\pm 75$  kHz Sweep Marker Generator.

STEP	TUNER DIAL SETTING	SIGNAL GENERATOR			INDICATOR	ADJUST	TEST LIMITS	REMARKS
		FREQ.	COUPLING	MODULATION				
1	Point of no interference.	10.7 MHz or point of no interference between 88-108 MHz.	Inject 10.7 MHz near IF Chassis or 88-108 MHz to tuner antenna terminals.	FM $\pm 200$ kHz sweep @60 Hz rate.	Oscilloscope.	TP 1	Top (primary) and bottom (secondary) of T2.	Keep signal generator output low to prevent limiting. TP 1 voltage should not exceed 0.5 volts. Rimo filters do not have a flat-topped response. See typical response curve (Fig. 2). If proper response cannot be obtained go to Step 2. Otherwise go to Step 3. Bottom covers must be on front end and discriminator chassis. Regeneration will distort sweep if either cover is removed.
2	Same	Same	Same	Same	Same	Same	Use standard insulated hex tool. Top and bottom cores of Rimo filters accessible thru bottom of IF Chassis	Carefully peak top and bottom cores of T201, T202, T205, and T206 for maximum gain at 10.7 MHz (center of IF bandpass), and then touch up all cores for best symmetry to obtain bandpass on opposite page. Do not stagger tune. Do not touch any other IF tuned circuits. Be sure selectivity switch is in normal position.

Move selectivity switch to Narrow Position.

3	Same	Same	Same	Same	Same	Same	Same	Same	Carefully peak top and bottom cores of T203, T204, T207, and T208 for maximum gain at 10.7 MHz (center of IF bandpass), and then touch up all cores for best symmetry to obtain bandpass in Fig. 3 below. Do not stagger tune. Do not touch any adjustments done in Step 2 above.
---	------	------	------	------	------	------	------	------	---

Move selectivity switch to Super Narrow Position.

4	Same	Same	Same	Same	Same	Same	Same	Use insulated screw driver.	Adjust C103 on top of Super Narrow IF Chassis for maximum symmetrical bandpass. Do not touch any adjustments made in Step 2 or 3 above.
---	------	------	------	------	------	------	------	-----------------------------	---

Move selectivity switch to Normal Position.

5	Same	10.7 MHz	Inject Signal near IF Chassis.	CW	VTVM	TP2	M301 adjust R610.	Zero DC at TP 2.	With tuner horizontal and right side up, M301 should be centered. 10.7 MHz frequency must be precise for this adjustment.
6	10.7 MHz or 88-108 MHz.	Inject Signal near IF Chassis or tuner antenna terminals.	FM +75 kHz @ 60 Hz rate.	Oscilloscope.	Fixed audio output jacks.	Bias pot R603.	Maximum audio output.	Maximum audio output.	If output is clipped, reduce audio output by adjusting R317; muting off, stereo filter out.
7	106 MHz.	300Ω antenna terminals thru matching network or balun.	400Hz; 75KHz deviation (Fig. 1)	VTVM to TP 1 and scope to L or R audio output.		Oscillator trimmer C25	Maximum negative voltage at TP 1.	Maximum negative voltage at TP 1.	Keep TP 1 voltage below one volt. Observe signal on scope for reference.
8	90 MHz	Same	Same	Same	Same	Oscillator Coil L5.	Same	Same	Same. Repeat Steps 5 and 6 until dial is accurate.

Antenna selector switch should be in the High Gain Position for the following:

9	104 MHz	104 MHz	Same	Same	Same	Adjust C5, C16, and C17.	Same	Same	Keep TP 1 voltage below one volt. Reduce signal input as circuits align.
10	92 MHz	92 MHz	Same	Same	Same	L2, L3, L4.	Same	Same	Same
11	104 MHz	104 MHz	Same	Same	Harmonic distortion analyzer to L or R output.	C4	Adjust for minimum noise and distortion at 5μV input.	Adjust for minimum noise and distortion at 5μV input.	Noise and distortion should be more than 30dB down. Noise with no modulation should be more than 40dB down. Touch up C5, C16, and C17 if necessary.

92 MHz	92 MHz	Same	Same	1 kHz at $\pm 75$ kHz deviation or Sound Technology Dual Sweep	Harmonic distortion analyzer to L or R output or Sound Technology to L or R output.	R603	Minimum distortion should be less than 0.2%.	A very low distortion FM generator is necessary. Sound Technology 1000A is recommended. Typical MR 78 distortion is 0.05% in this test. Minimum distortion should correspond closely to maximum audio output. If Sound Technology 1000A is used, adjust R603 for smoothest horizontal dual-sweep pattern. Refer to Sound Technology manual. Check 1kHz harmonic distortion.	Same	Touch up L2, L3, and L4 only if necessary.				
Repeat Steps 9 and 10 until no further improvement is possible. Always adjust for minimum noise and distortion.														
92 MHz	92 MHz	Same	Same	1 kHz at $\pm 75$ kHz deviation.	Oscilloscope connected to L or R output.	R610		Reduce signal strength until noise appears on tips of signal. If necessary, adjust R610 so that tuning meter is centered.	Same					

Move antenna selector to <u>Low Gain</u> Position.												
STEP	TUNER DIAL SETTING	SIGNAL GENERATOR			INDICATOR		ADJUST	TEST LIMITS	REMARKS			
		FREQ.	COUPLING	MODULATION	TYPE	CONNECTED TO						
16	Same	Same	Same	Same	Harmonic distortion analyzer to L or R output.		Set generator for 2.5µV output in 300Ω.	Total noise and distortion should be more than 30dB down. Noise with no modulation should be more than 40dB down.				
17	104 MHz	Same	Same	Same	Same		Same	Same IF distortion and noise are out of spec., repeat Steps 11 thru 13. Be sure selectivity switch is in normal.				
18					<p>IF Gain Check With Selectivity Switch. Feed a 100% modulated 1 kHz mono signal to the tuner and set signal generator RF level to 10µV. Move selectivity switch to all three positions and observe signal strength meter. (Meter switch should be on signal strength.) Repeat with RF levels of 100, 300, 1000, 10,000, and 100,000µV. The signal strength meter should not vary more than one S-unit when selectivity switch is moved. If it does, there is a variation in the IF amplifier due to mal-function or misalignment. Recheck alignment Steps 1 thru 6. Check M401 calibration. With selectivity on broad, M401 should read 6 on a 500µV signal and 10 on a 200µV signal. If not, adjust R212 to read 6 on a 500µV signal and R226 to read 10 on a 30,000µF signal. (Antenna selector should be in low gain position.)</p>							

### MULTIPLY DECODER ALIGNMENT

STEP	TUNER DIAL SETTING	SIGNAL GENERATOR			INDICATOR		ADJUST	TEST LIMITS	REMARKS
		FREQ.	COUPLING	MODULATION	TYPE	CONNECTED TO			
	100 MHz	Same as	300Ω	Mono (R = L)	Oscilloscope and AC-	R317	2-5V RMS at 2.5kHz	Make sure tuning meter is at zero center. Maximum indication on signal strength meter.	

Move selectivity swi. to Narrow Position.

1	100 MHz or point of no interference	Same as tuner dial	300Ω antenna terminals with approxi- mately 10000μV signal thru matching network or balun	Mono (R = L) 1 kHz 100% modulation	Oscilloscope and AC-VTVM connected to either fixed audio output jack.	R317	2.5V RMS at fixed output jacks	Make sure tuning meter is at zero center. Maximum indication on signal strength meter and center indication on tuning meter should coincide.
2	Same	Same	Same	67kHz and 53kHz at +75kHz deviation	Oscillo- scope	L302 and L303	Adjust L302 for maximum 53kHz, L303 for minimum 67kHz. Do not attempt to detect 67kHz at tuner output jacks. Ground scope probe close to multiplex board. Repeat adjustments of L302 and L303 until optimum condition is reached.	
3	Same	Same	Same	19 kHz pilot	Oscillo- scope	L301 and T301	For maximum amplitude	Decrease pilot level, if necessary, so that 19 kHz circuits do not limit or saturate.
4	Same	Same	Same	Same	Oscillo- scope	T302 top and bottom	Maximum amplitude	Use normal (9%) pilot level. Remove scope probe before going to Step 5.
5	Same	Same	Same	Stereo 1 kHz (100% modulation) left only pilot level normal and on	AC-VTVM	T302 bottom (sec) and R423	40dB separation or more	First set R401 to maximum resistance. (Fully clockwise looking from front of tuner.) Adjust T302 bottom tuning slug (sec) for minimum output on right (undesired) channel. Then adjust R401 for maximum separation. Repeat the adjustment of T302 bottom and R401 until maximum separation is obtained. Then reverse channels and measure left channel separation.
6	Same	Same	Same	Stereo pilot carrier modulation only	AC-VTVM	L or R output jack	Less than 50MV of residual	With modulation off but pilot on. (NOTE: Stereo generator must have low spurious output.)

FIG. 1 ANTENNA MATCHING NETWORK

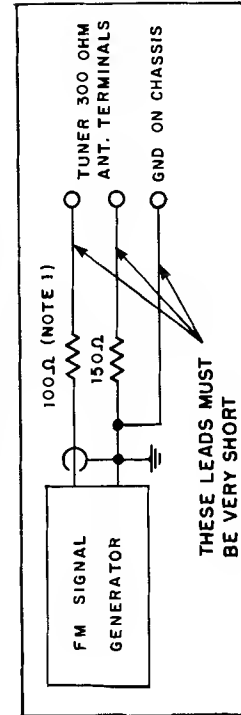

FIG. 2 TYPICAL IF RESPONSE CURVE NORMAL

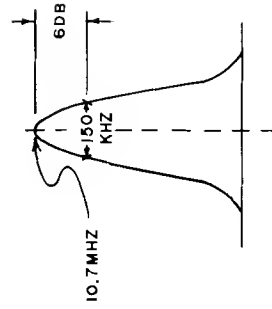
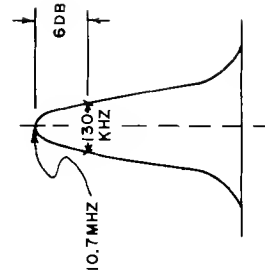

FIG. 3 TYPICAL IF RESPONSE CURVE NARROW



## REPLACEMENT PARTS

All parts not listed are common items obtainable from radio parts jobbers.

Replacement parts may be obtained when ordered by PART NUMBER from:

McIntosh Laboratory, Inc.  
Customer Service Department  
2 Chambers Street  
Binghamton, New York 13903  
(telephone 607-723-3512)

## CAPACITORS

C29,30	Silver Mica	270pF		063-010
C204	Elect.	10μF	35V	066-173
C304	Tant.Elect.	10μF	20V	066-239
C306	Tant.Elect.	22μF	25V	066-240
C308	Tant.Elect.	6.8μF	35V	066-146
C309	Polystyrene	2700pF		064-093
C310	Tant.Elect.	10μF	20V	066-239
C311	Polystyrene	1500pF		064-092
C314	Tant.Elect.	6.8μF	35V	066-146
C316	Tant.Elect.	6.8μF	35V	066-146
C323	Tant.Elect.	1μF	50V	066-242
C325	Tant.Elect.	22μF	25V	066-240
C326,327	Polystyrene	4700pF		064-091
C328	Tant.Elect.	6.8μF	35V	066-146
C331	Polystyrene	.0033μF		064-090
C334	Polystyrene	.0033μF		064-090
C401,402	Polystyrene	2700pF		064-093
C403	Polystyrene	.033μF		064-089
C406,407	Elect.Cap.	22μF	35V	066-179
C411	Elect.Cap.	10μF	50V	066-221
C412	Polystyrene	2700pF		064-093
C413	Tant.Elect.	1μF	50V	066-242
C414	Elect.	10μF	50V	066-221
C503	Elect.	2000μF	50V	066-154
C504	Elect.	5/300/150/1000μF		066-155
		200/50/50/30V		
C506	Elect.	150μF	63V	066-205
C507	Elect.	47μF	16V	066-215

## DIODES

D1	Pin diode			070-055
D2	Si. signal diode			070-047
D3	Pin diode			070-055
D101,102	Si. signal diode			070-047
D103	Si. signal diode			070-047
D104,105	Ge. signal diode			070-003

D201,202	Si. signal diode			070-047
D203	Si. signal diode			070-047
D204	Ge. signal diode			070-003
D205	Si. signal diode			070-047
D206,207	Ge. signal diode			070-003
D208,209	Si. signal diode			070-047
D210	Ge. signal diode			070-003
D211,212	Si. signal diode			070-047
D213,214	Ge. signal diode			070-003
D215,216	Ge. signal diode			070-003
D301,302	Si. signal diode			070-047
D303,304	Si. signal diode			070-047
D305,306	Si. signal diode			070-047
D308,309	Si. signal diode			070-047
D310,311	Si. signal diode			070-047
D401	Si. signal diode			070-047
D502,503	Si. signal diode			070-031
D504	Si. signal diode			070-031
D505	Zener diode	24V		070-065
D506	Si. signal diode			070-031
D601,602	Si. signal diode			070-081
D603,604	Si. signal diode			070-081

## CHOKES

L1	Antenna Coil			122-133
L2	RF input Coil			122-132
L3	RF output Coil			122-131
L4	Mixer Coil			122-130
L5	Oscillator Coil			122-129
L6	Choke 75μH			122-013
L7	Choke 1.7μH			122-032
L301	Filter Coil (19kHz)			122-094
L302,303	Filter Coil (SCA)			122-093
L304	Choke 1MH			122-092
L501	Choke 2.2μH			122-001

## TRANSISTORS

Q1	Si. N Channel J.F.E.T.			132-097
Q2	Si. NPN transistor			132-066
Q3	Si. NPN transistor			132-087
Q101,102	M.O.S. F.E.T.			132-088
Q201,202	Si. Junction FET			132-068
Q301	Si. NPN transistor			132-092
Q302	Si. NPN transistor			132-094
Q303	Si. NPN transistor			132-092
Q304,305	Si. NPN transistor			132-094

Q306	Si. NPN transistor	132-095	T208	FM IF filter output	162-052
Q401	Si. PNP transistor	132-096	T301	RF transformer (19kHz)	162-055
Q402	Si. NPN transistor	132-090	T302	RF transformer (38kHz)	162-054
Q403	Si. PNP transistor	132-096	INTEGRATED CIRCUITS		
Q404	Si. NPN transistor	132-090	IC1	Integrated circuit	133-006
Q405	Si. NPN transistor	132-094	IC101,102	Integrated circuit	133-002
Q501	Si. NPN transistor	132-065	IC301A,13	Integrated circuit	133-004
Q502	Si. PNP transistor	132-032	METERS		
Q601,602	Si. NPN transistor	132-066	M301	Tuning meter	124-020
FUSES			M401	Signal strength meter	124-019
F501	Fuse .5A slo-blo	089-020	RELAY		
POTENTIOMETERS			K301	Reed relay	087-008
R212	M401 mid scale adv.	134-260	LAMPS		
R226	M401 full scale adv.	134-260		Function lamp	058-043
R317	Audio level	134-258		Stereo lamp	058-042
R422	Volume control	134-217		#1847 (Meter lamp)	058-008
R423	Separation adv.	134-260		#1866 (Front panel)	058-014
R603	Bias adv.	134-256		Festoon lamp (Dial glass)	058-032
R610	M301 adv.	134-256	FRONT PANEL & TRIM		
RESISTORS				Front panel	044-345
R10	wire 220 $\Omega$ 5' 1W	139-076		Front panel end caps	018-154
R333,334	film 33K 1/2 1W	144-015		Tuning knob	044-357
R338,339	film 33K 1/2 1W	144-015		Selectivity knob	090-175
R503	wire 15 $\Omega$ 10' 5W	139-041		Meter knob	090-175
R508	wire 2.0 $\Omega$ 10' 5W	139-005		Filter knob	090-175
R509	wire 1.8 $\Omega$ 10' 1W	139-077		Muting knob	090-175
R605,606	wire 220 $\Omega$ 5' 1W	139-076		Mode knob	090-175
R607,608	film 56.2 $\Omega$ 1/2 1W	144-014		Volume knob	090-175
SWITCHES			MOUNTING SYSTEM		
S2	Selectivity switch	146-156		Shelf brkt (right)	043-592
S301	Mode selector	146-160		Shelf brkt (left)	043-593
S302	Muting switch	146-159		Mounting temp #100	038-179
S401	Stereo filter switch	146-158		Hardware Package	044-454
S402	Meter function switch	146-157	MISCELLANEOUS ITEMS		
TRANSFORMERS				FM dipole antenna	170-033
T1	Balun	043-226		Dial glass	044-474
T2	FM mixer	162-062		Pointer	044-387
T201	FM IF filter input	162-053		Dial cord (complete)	044-475
T202	FM IF filter output	162-052		Fuseholder	178-001
T203	FM IF filter input	162-053		AC power cord	170-021
T204	FM IF filter output	162-052		Shipping carton	044-473
T205	FM IF filter input	162-053		Owners manual	038-868
T206	FM IF filter output	162-052		Plastic feet	017-041
T207	FM IF filter input	162-053		Push terminal (antenna)	074-033
				Audio cable 6'	170-015