

McIntosh

MR 77

FM TUNER

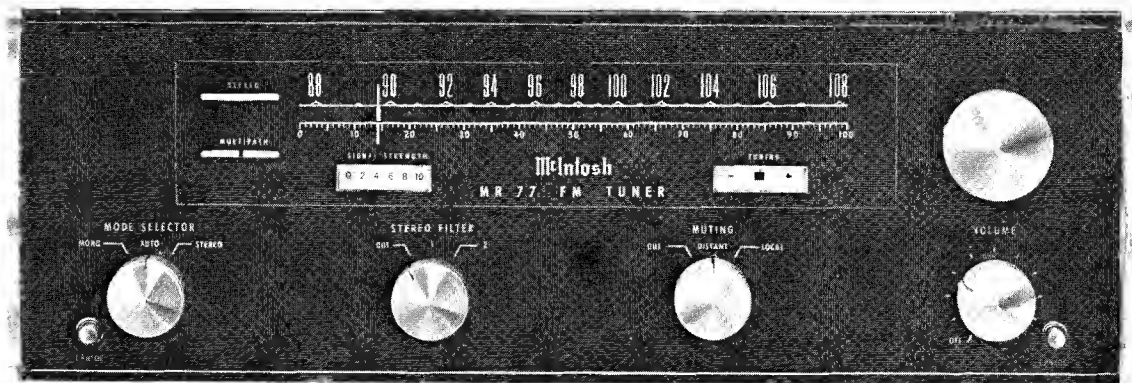

SERVICE INFORMATION

STARTING WITH SERIAL NO. 53Y82

McINTOSH LABORATORY INC. 2 CHAMBERS STREET BINGHAMTON, NEW YORK

MR 77

ELECTRICAL SPECIFICATIONS

SENSITIVITY

2 μ V for better than 35dB quieting. 2.5 μ V IHF usable sensitivity typical.

SIGNAL TO NOISE RATIO

Better than 75dB below 100% modulation.

HARMONIC DISTORTION

Less than 0.2% mono or stereo at 100% modulation 20Hz to 15kHz. Typically less than 0.05% at 1kHz.

FREQUENCY RESPONSE

\pm 1dB 20Hz to 15KHz with standard 75 μ S de-emphasis.

CAPTURE RATIO

Better than 2.5dB IHF.

SPURIOUS REJECTION

Greater than 100dB IHF.

IMAGE REJECTION

Greater than 100dB at 90MHz; greater than 90dB at 105MHz IHF.

STEREO SEPARATION

Better than 40dB at 1kHz.

SCA FILTER

50dB down from 67kHz to 74kHz; 275dB per octave slope.

POWER REQUIREMENTS

117VAC, 50 - 60Hz, 35W.

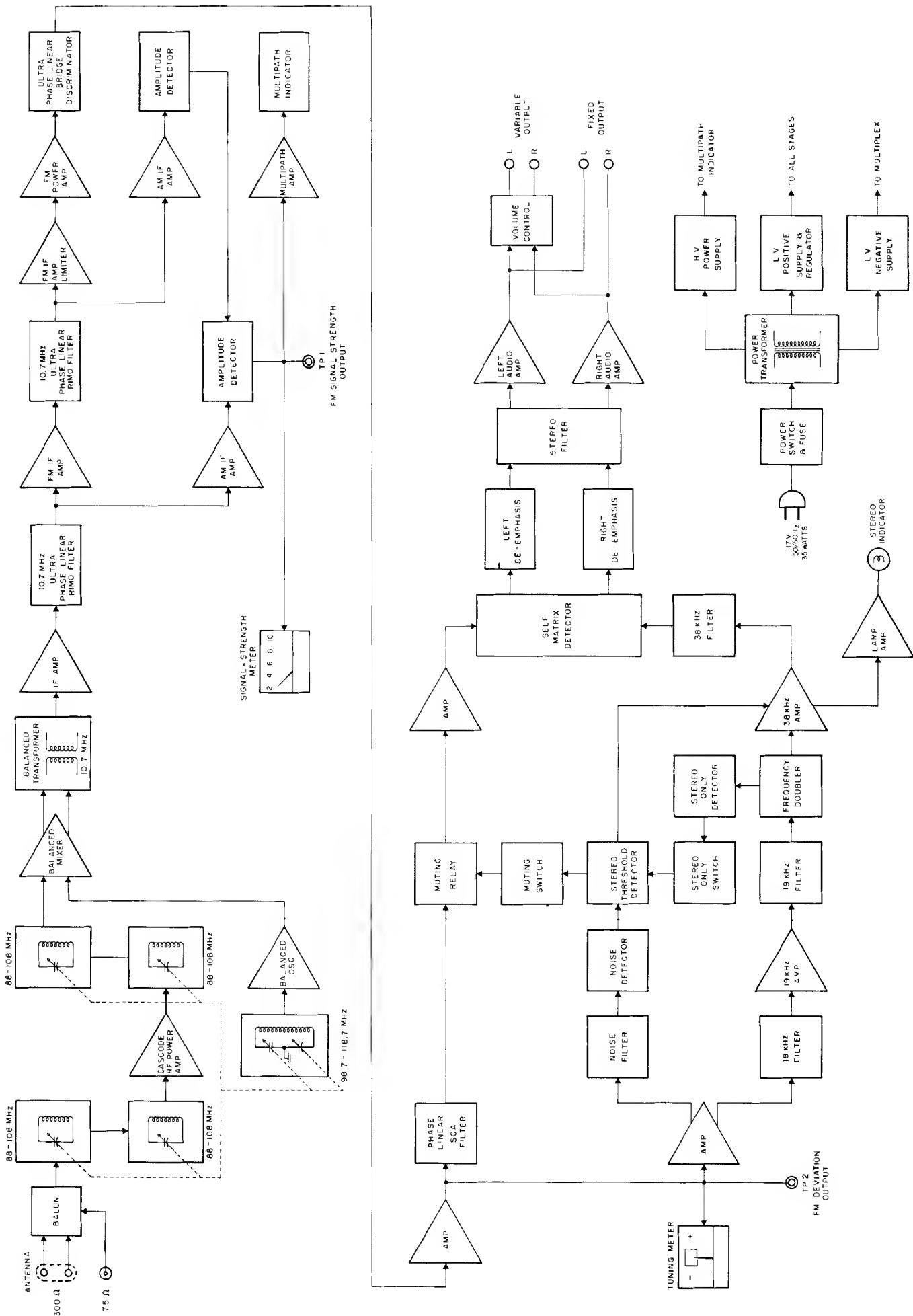

MR 77 BLOCK DIAGRAM

DETECTOR PRINTED CIRCUIT BOARD 044-116

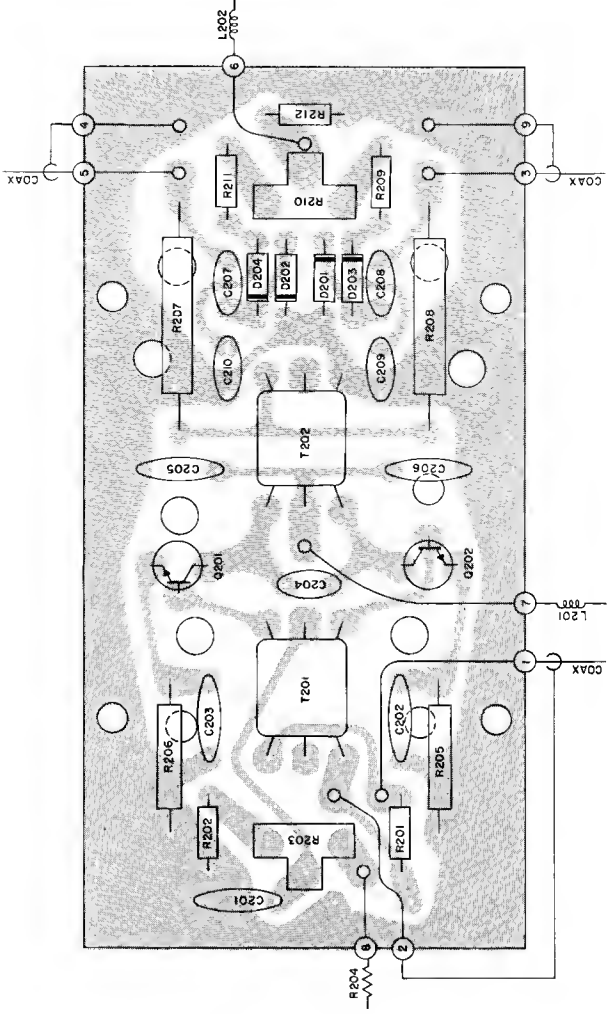

I.F. PRINTED CIRCUIT BOARD 044-117

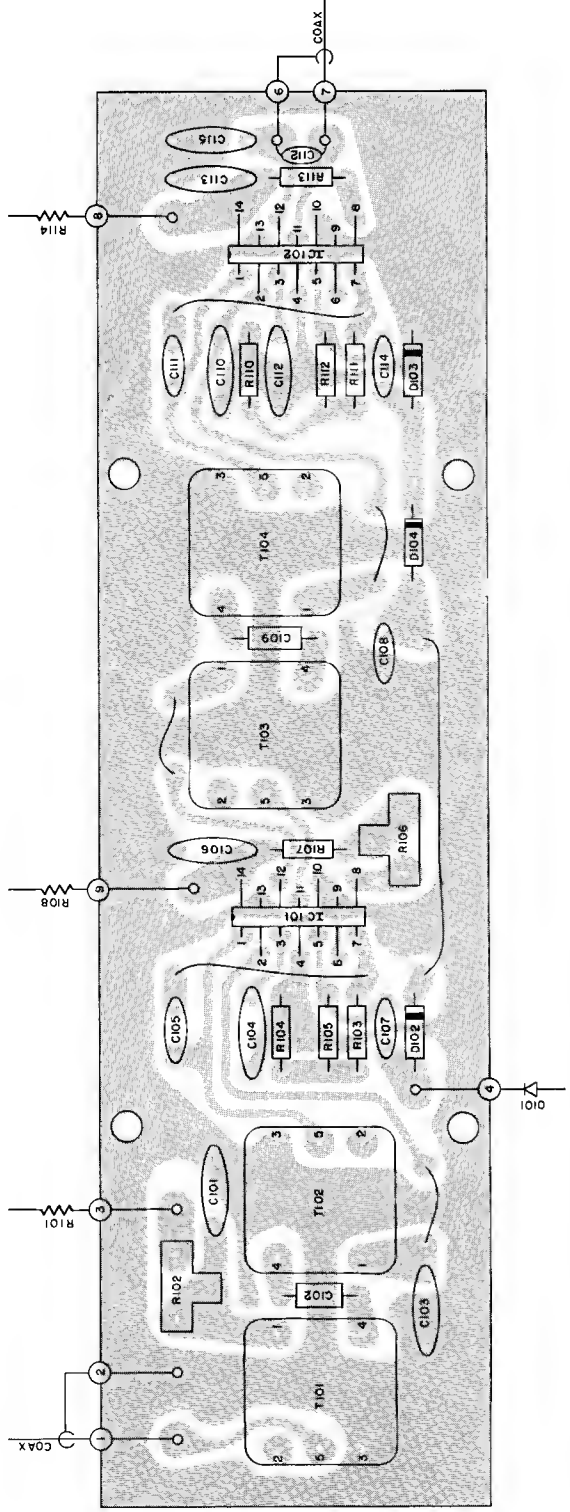

FM ANTENNA

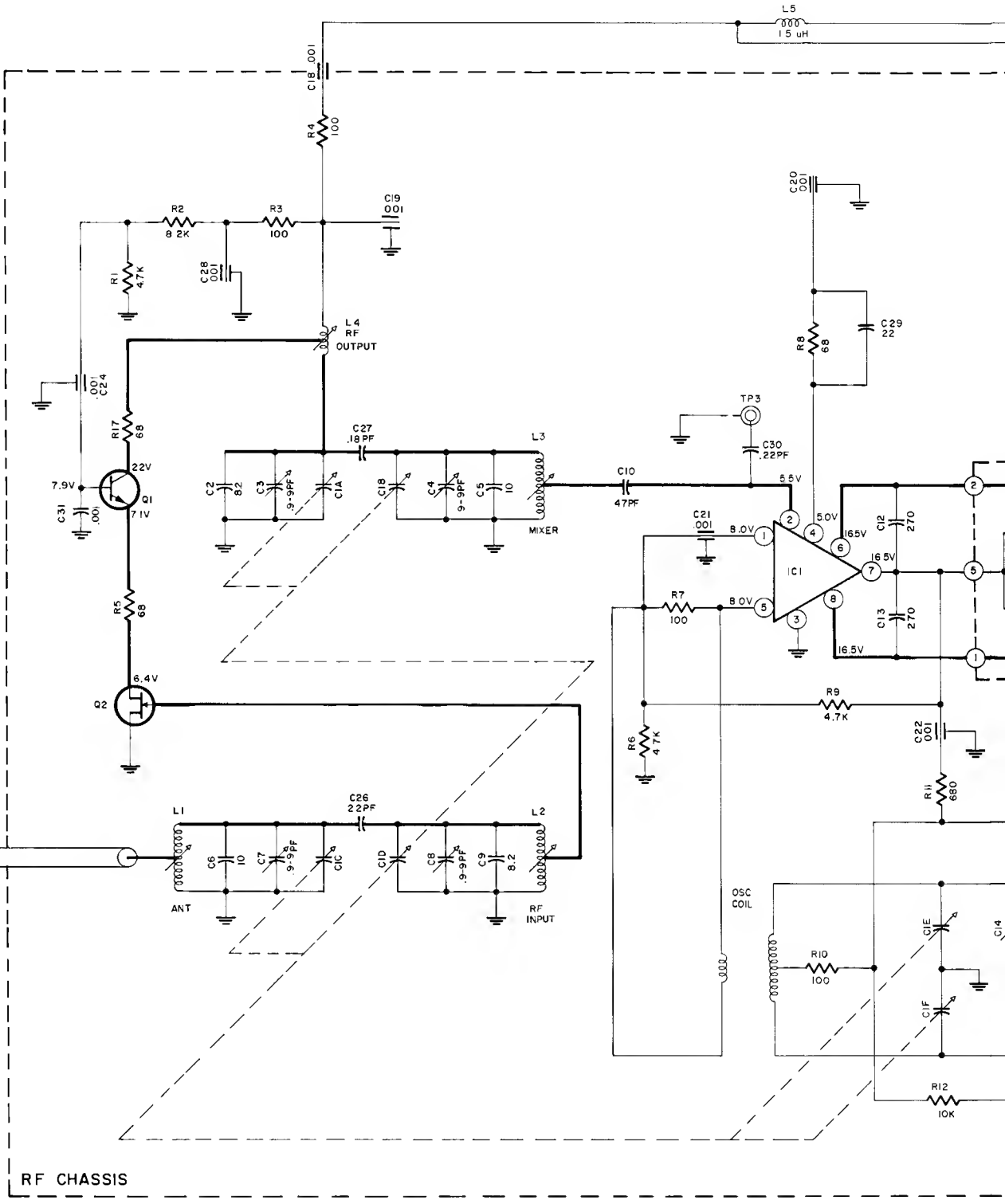
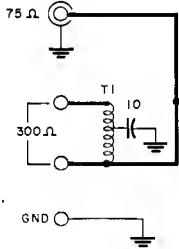

RF CHASSIS

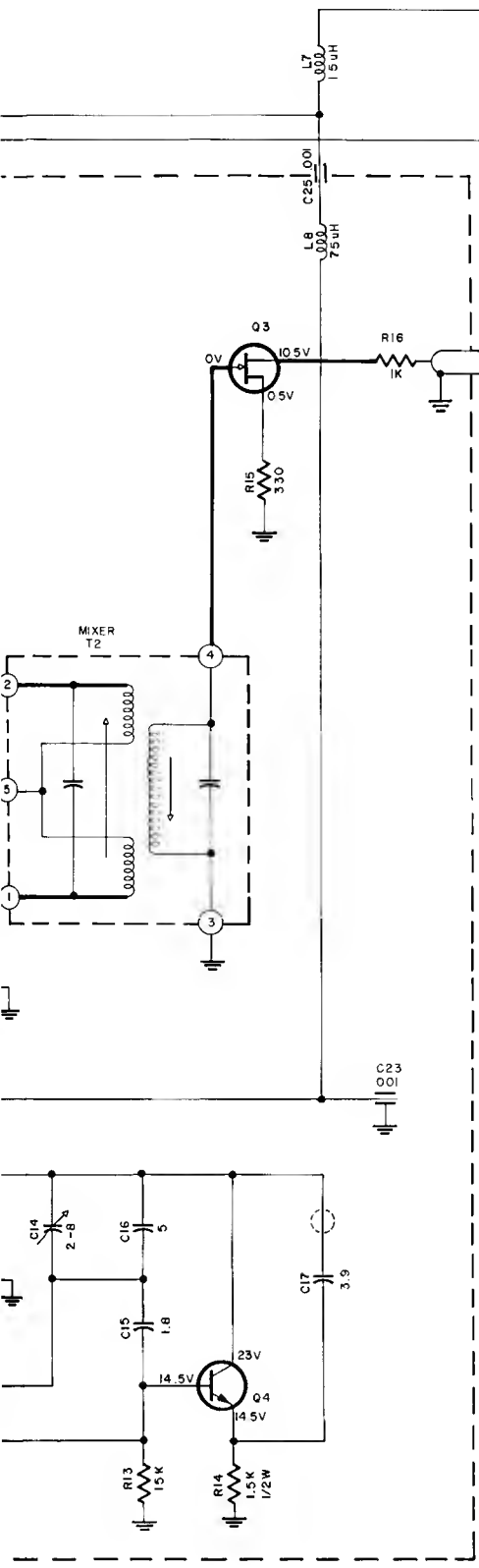

IF CHASSIS

IF PRINTED CIRCUIT BOARD 044-117

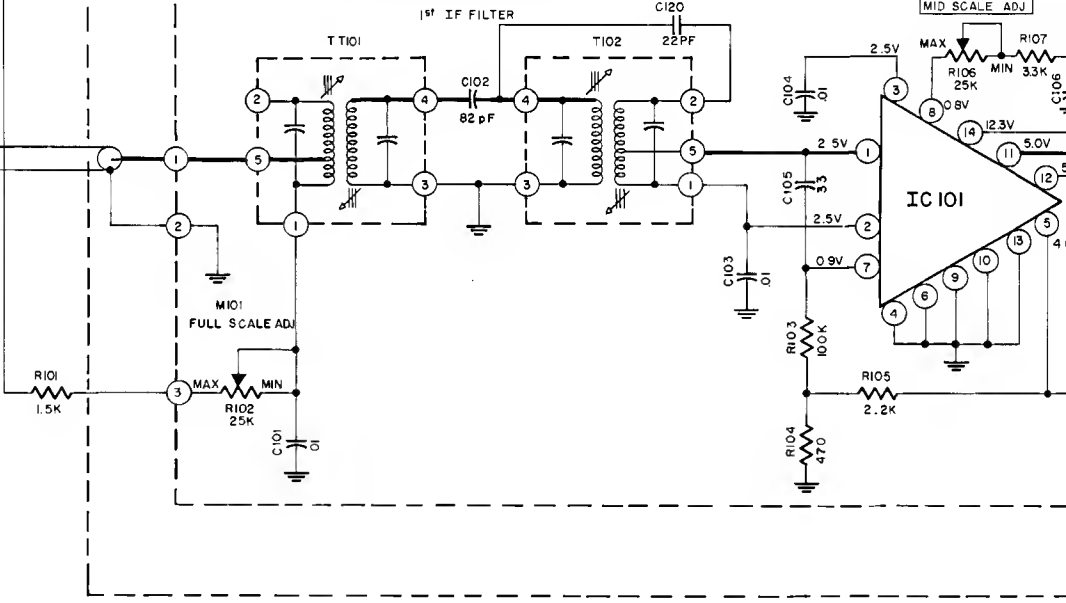

FM DETECTOR CHASSIS

FM DETECTOR PRINTED CIRCUIT BOARD 044-116

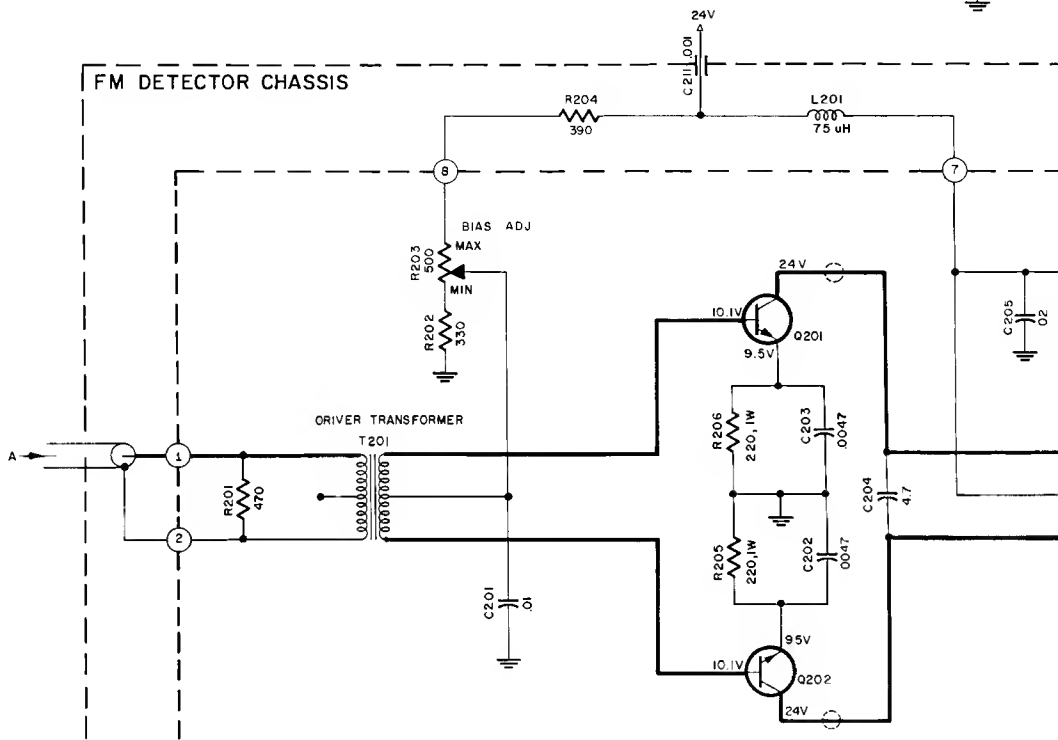

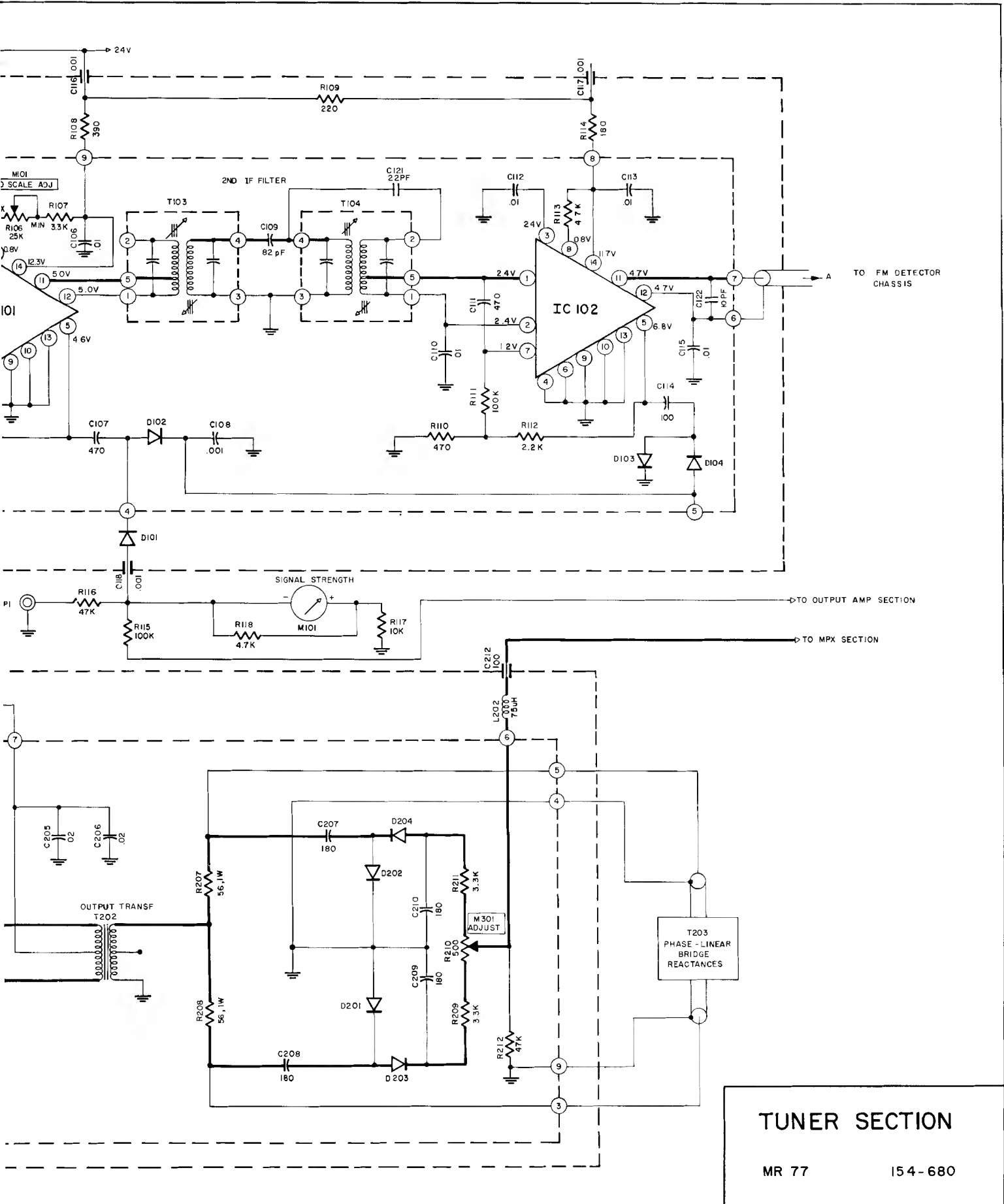

TUNER SECTION

MR 77

154-680

SCHEMATIC NOTES

1. Unless otherwise specified: Resistance values are in ohms, 1/4 watt, and 10% tolerance; capacitance values smaller than 1 are in microfarads (μF); capacitance values greater than 1 are in picofarads (pF); inductors are in microhenries (μH).
2. Printed circuit board components are outlined on the schematics by dotted lines. The circled numbers around the dotted lines correspond to the numbers on the PC Board layouts.
3. The heavy lines on the schematics denote the primary signal path.
4. The terminal numbering of rotary switches is for reference only.
5. All voltages indicated on the schematics are measured under the following conditions:
 - a. Use of an 11 megohm input impedance VTVM.
 - b. All voltages $\pm 10\%$ with respect to chassis ground.
 - c. No signal at input or antenna terminals.
 - d. AC input at 117 volts, 50/60 Hz.
 - e. Front panel controls at:

Tuning Indicator	100MHz (no signal)	Muting	Off
Volume	Fully CW	Mode	Auto
Stereo Filter	Out	Panel Lights	Bright

Tuning Indicator	100MHz (no signal)	Muting	Off
Volume	Fully CW	Mode	Auto
Stereo Filter	Out	Panel Lights	Bright

LAMP & METER REPLACEMENT

To Replace Panel Lights
1. Remove bottom cover.

To Replace Dial Panel Lights
1. Remove knobs & front panel.

To Replace Stereo Light
1. Remove dust cover.

To Replace Multipath Tube
1. Remove knobs & front panel.
2. Remove dial panel screws.
3. Tilt dial panel forward.
4. Slide out tube.

To Replace Meters
1. Remove knobs & front panel.
2. Remove dial panel screws.
3. Tilt forward dial panel sliding off pointer.
4. Loosen meter screws & remove.

FROM TUNER SECTION
FM DET CHASSIS

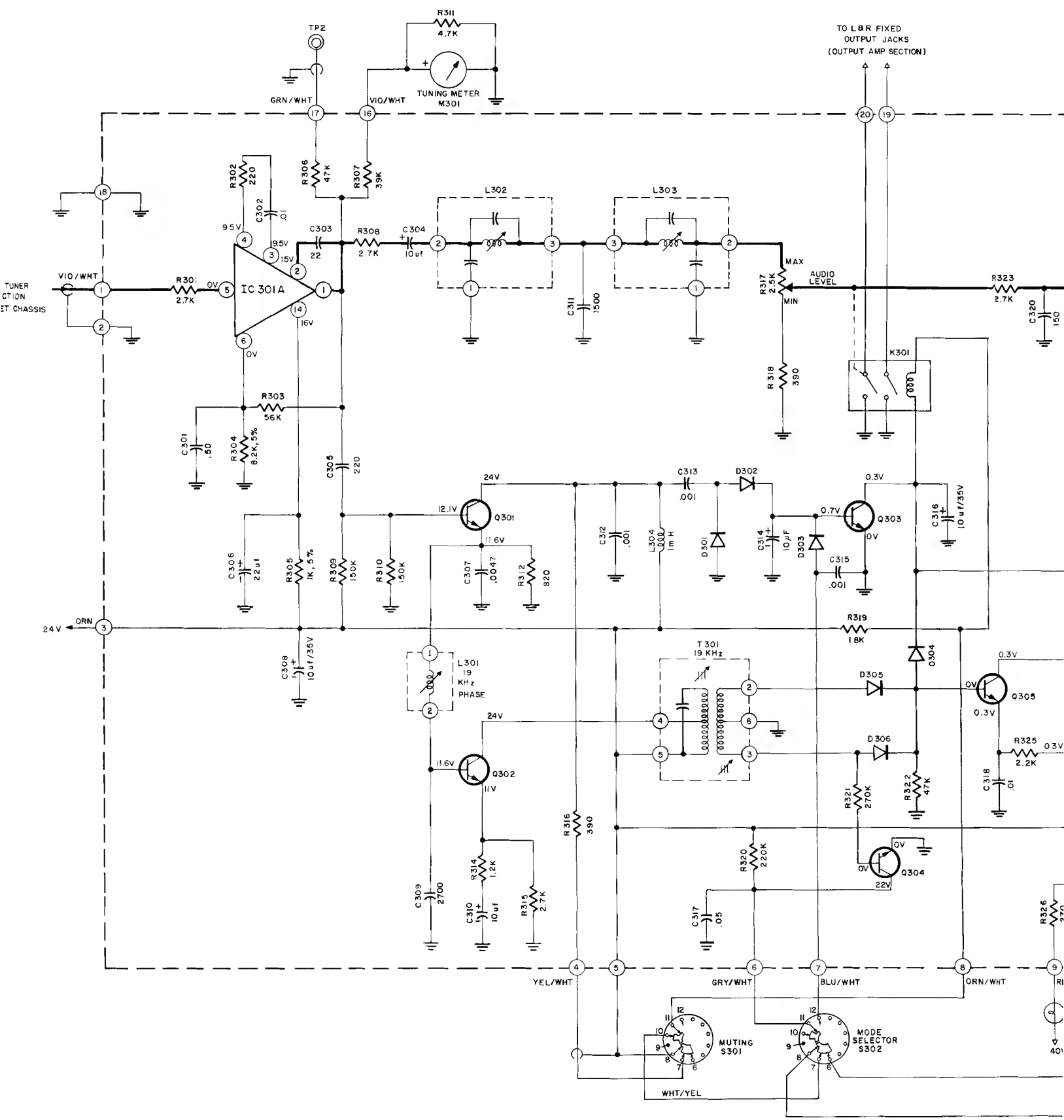

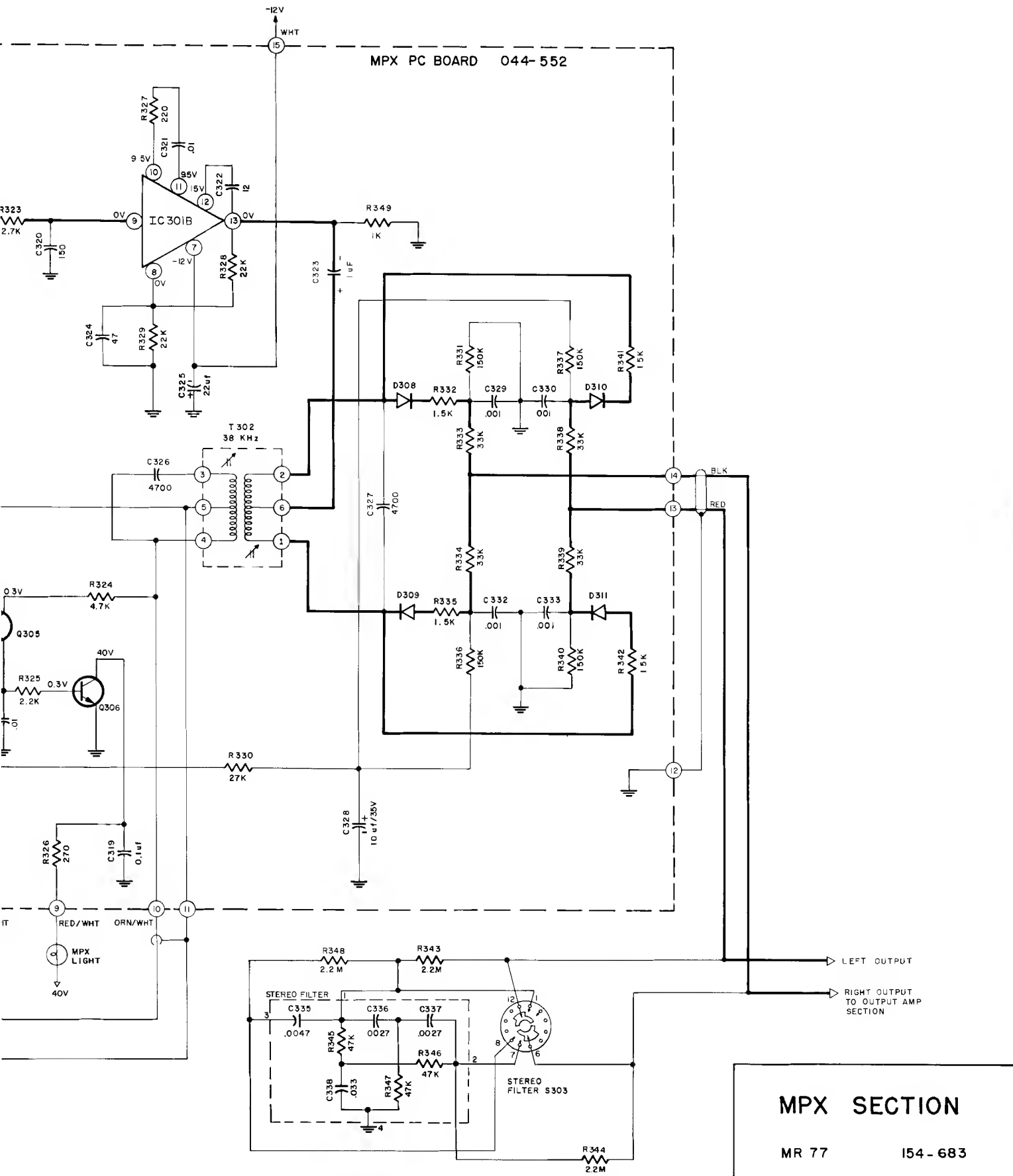

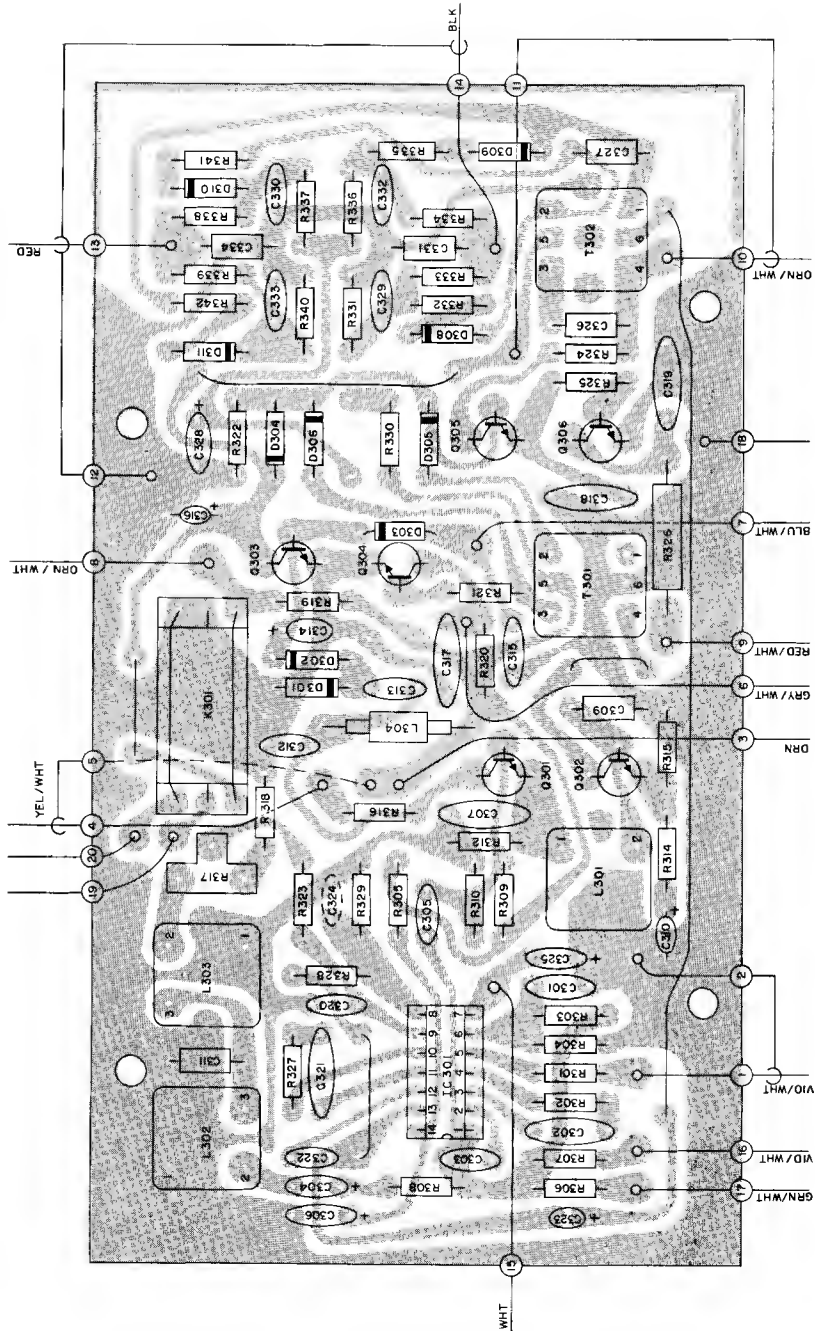

MPX PRINTED CIRCUIT BOARD O44-552

POWER SUPPLY PRINTED CIRCUIT BOARD 044-115

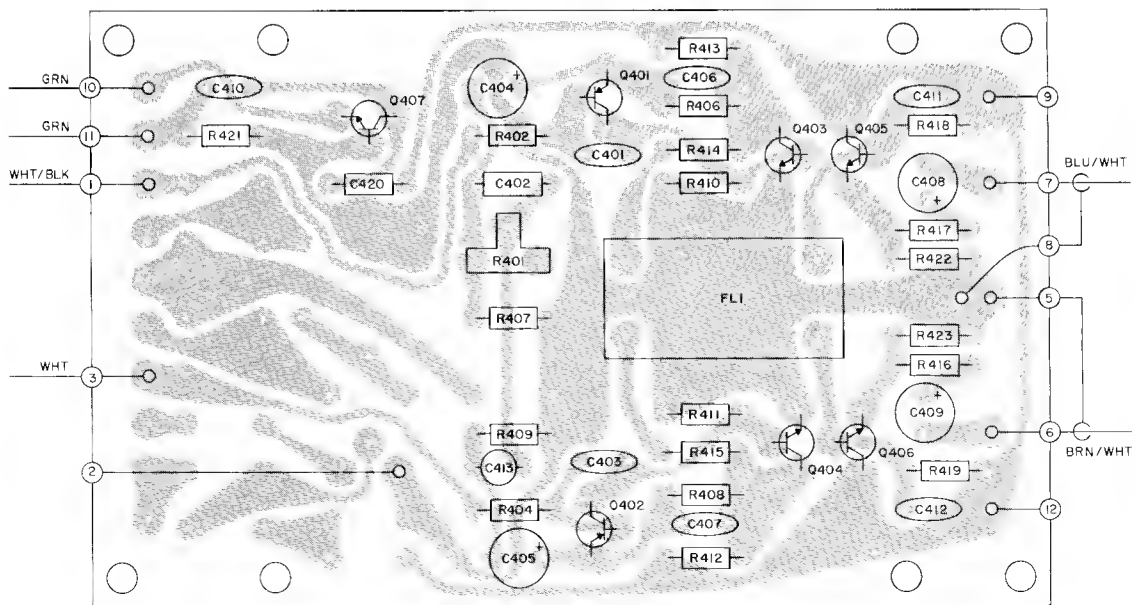
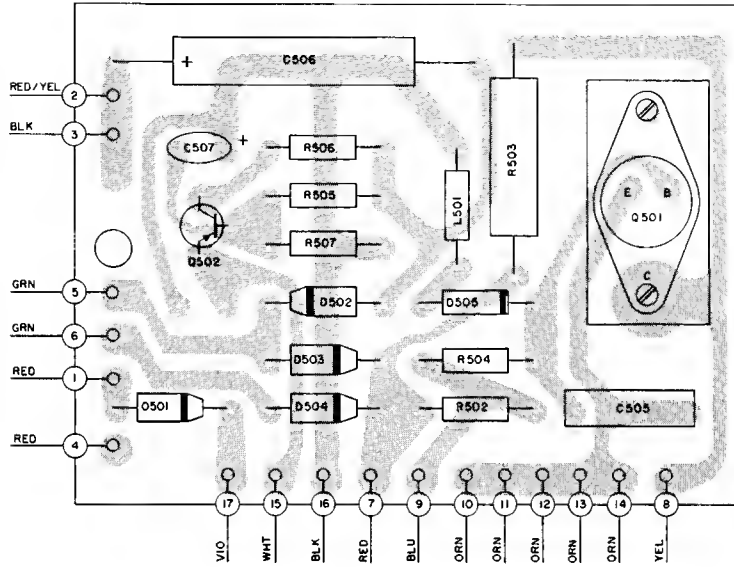

OUTPUT AMPLIFIER PRINTED CIRCUIT BOARD 044-793

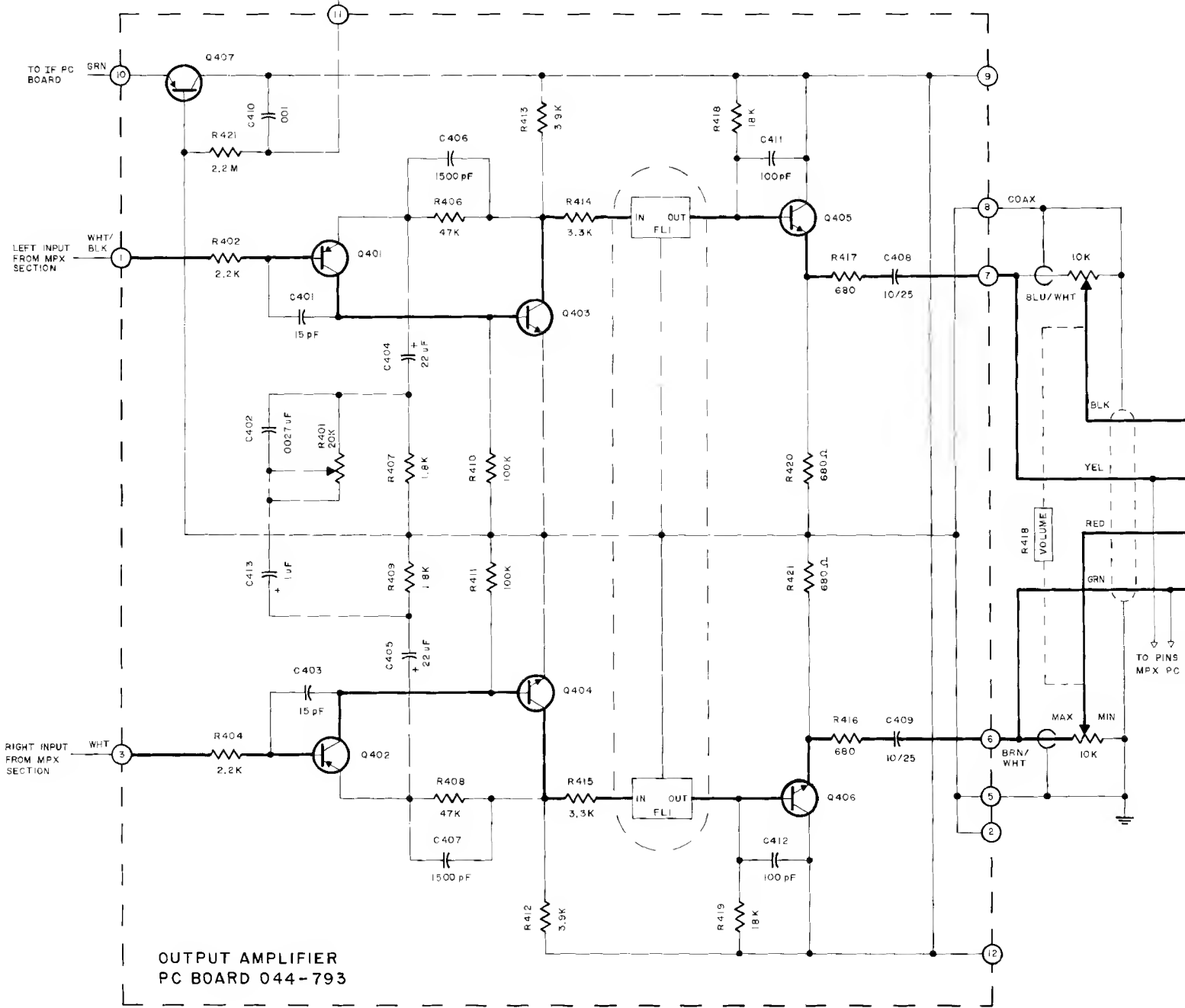
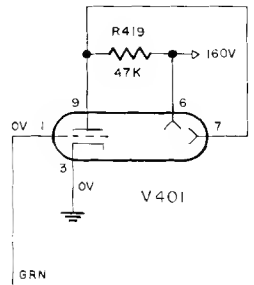

OUTPUT AMPLIFIER
PC BOARD 044-793

OUTPUT AMP
SECTION
MR 77

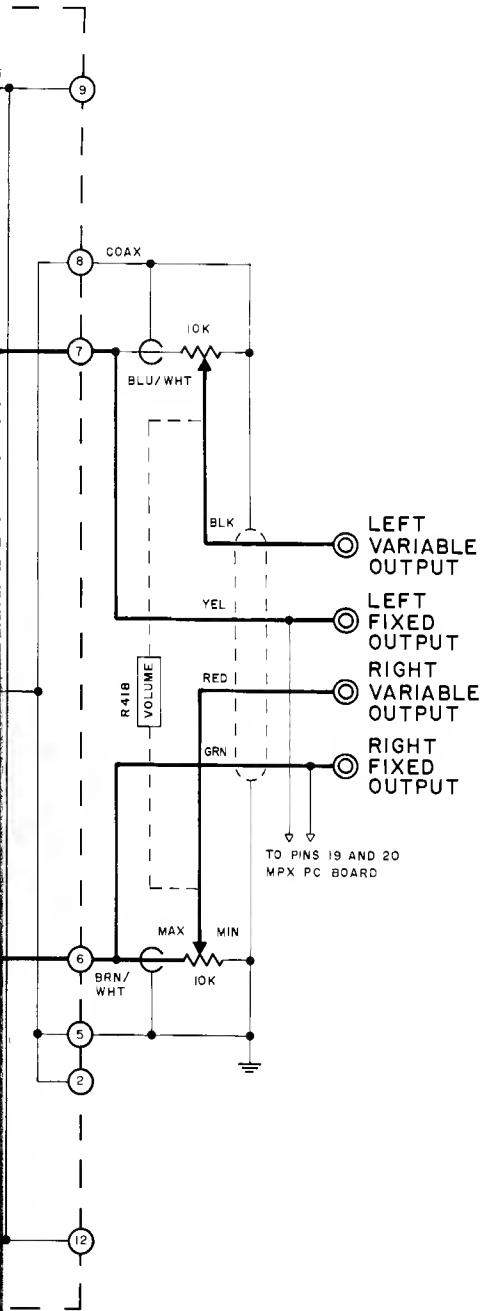

OUTPUT AMPLIFIER SECTION

MR 77

154-684

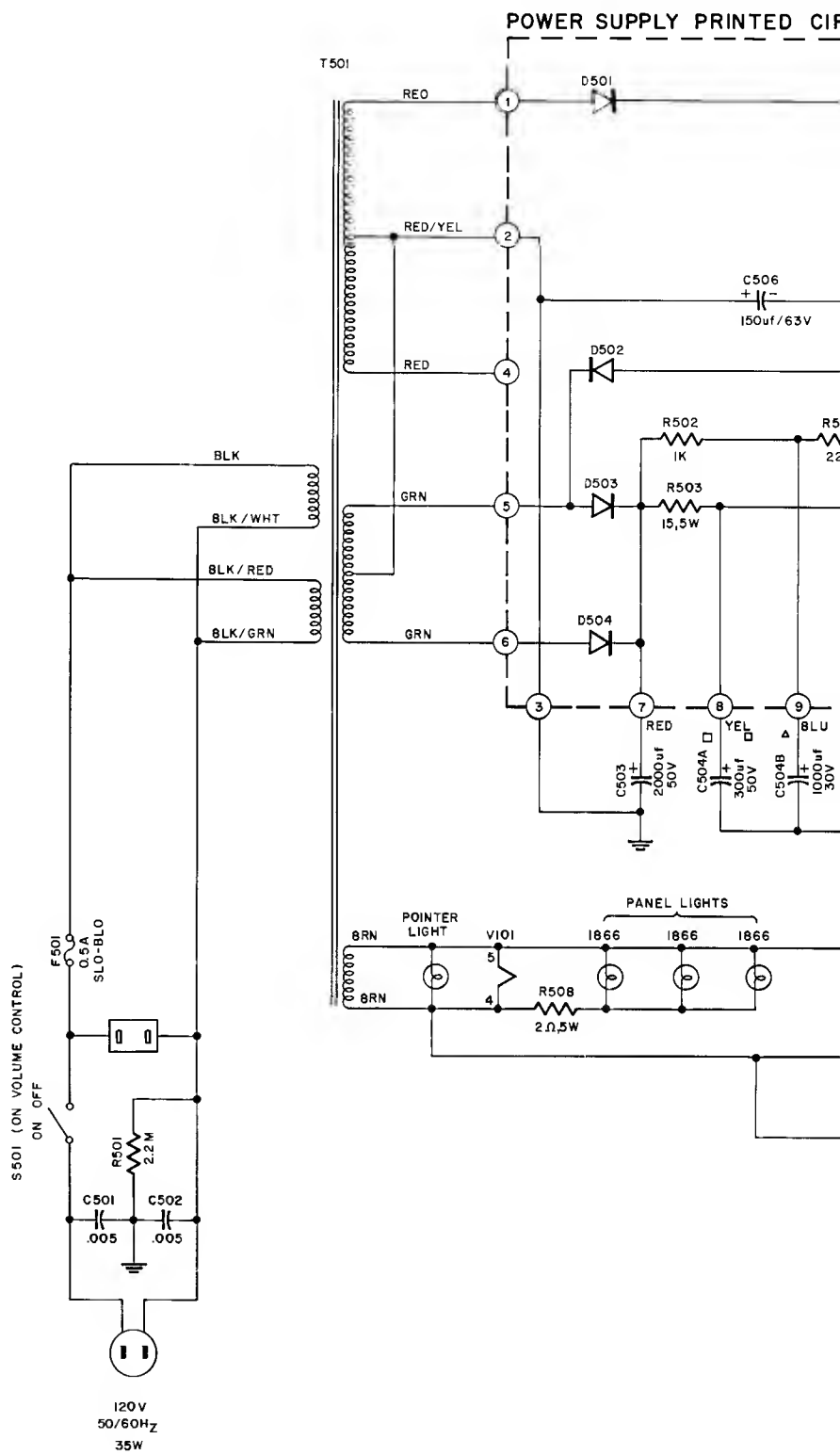

POWER SUPPLY PRINTED CIRCUIT BOARD 044-115

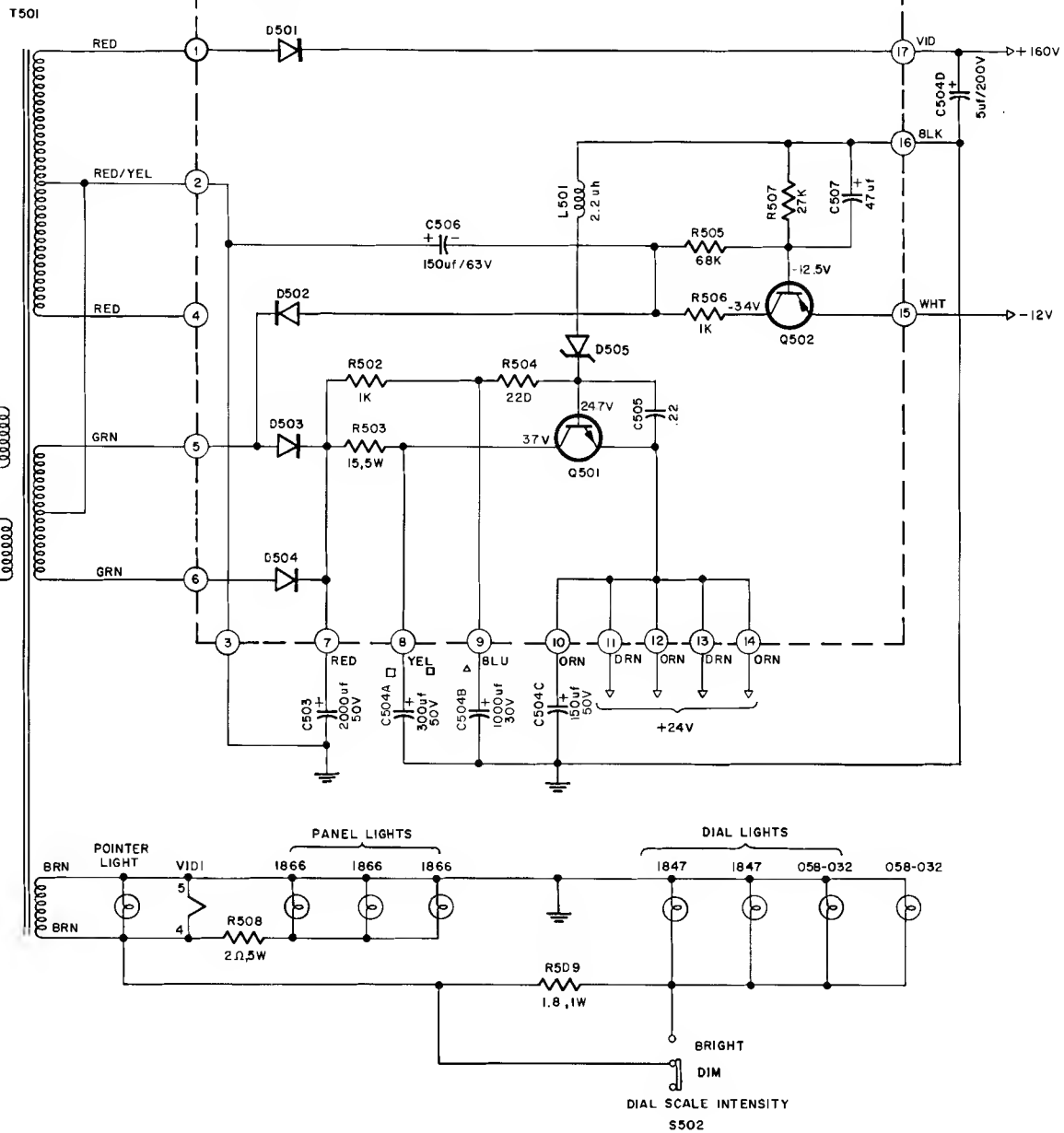

POWER SUPPLY SECTION

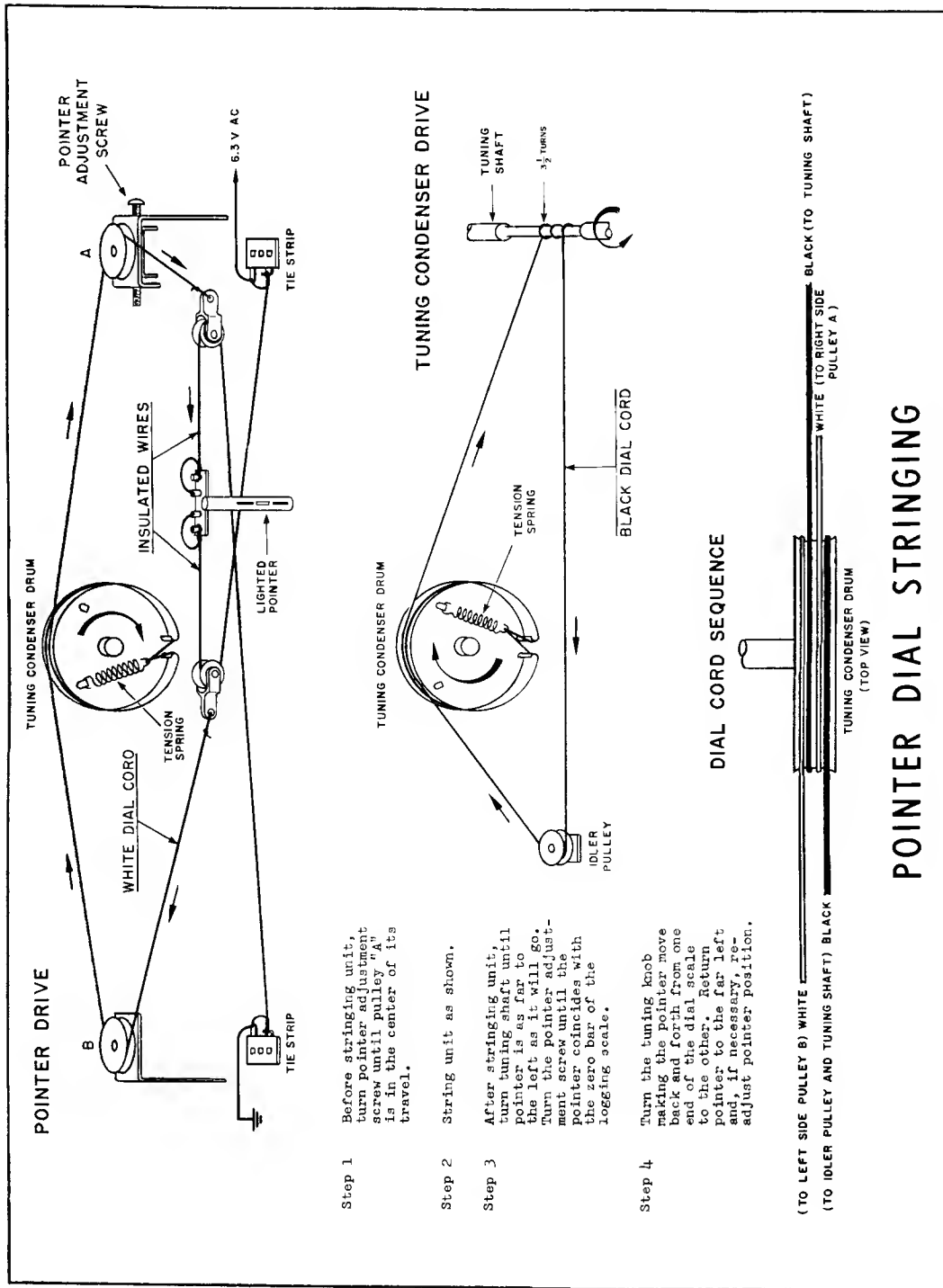

POINTER DRIVE

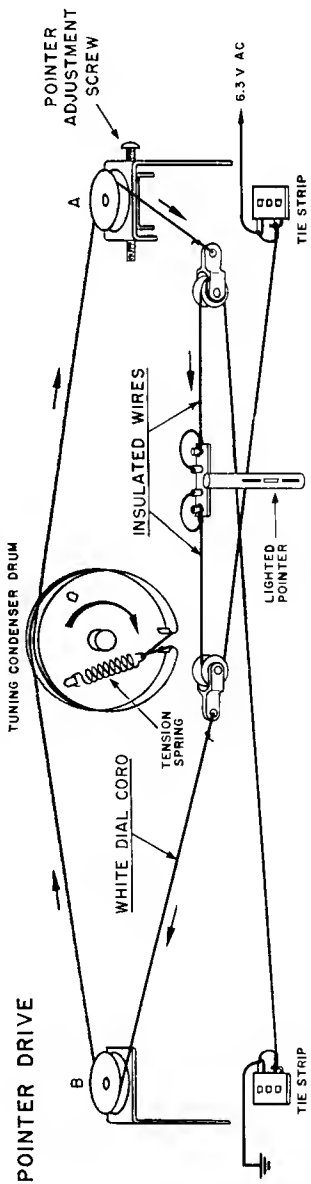

Step 1 Before stringing unit, turn pointer adjustment screw until pulley "A" is in the center of its travel.

Step 2 String unit as shown.

Step 3 After stringing unit, turn tuning shaft until pointer is as far to the left as it will go. Turn the pointer adjustment screw until the pointer coincides with the zero bar of the logging scale.

Step 4 Turn the tuning knob making the pointer move back and forth from one end of the dial scale to the other. Return pointer to the far left and, if necessary, re-adjust pointer position.

TUNING CONDENSER DRIVE

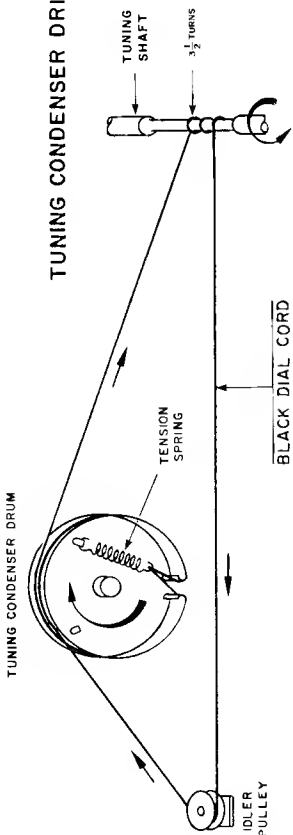

DIAL CORD SEQUENCE

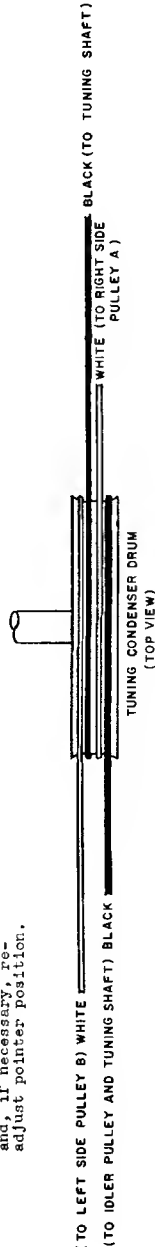

POINTER DIAL STRINGING

POWER SUPPLY
P.C. BOARD

DIAL CORD SEQUENCE

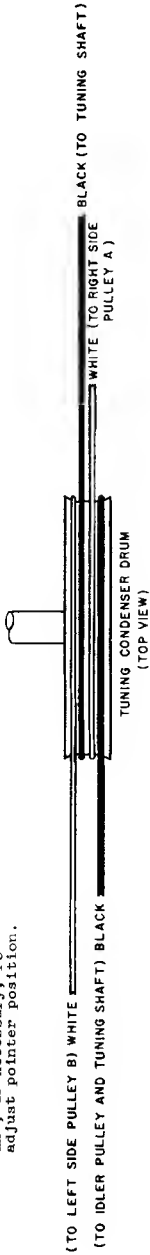

POINTER DIAL STRINGING

making the pointer move back and forth from one end of the dial scale to the other. Return pointer to the far left and, if necessary, re-adjust pointer position.

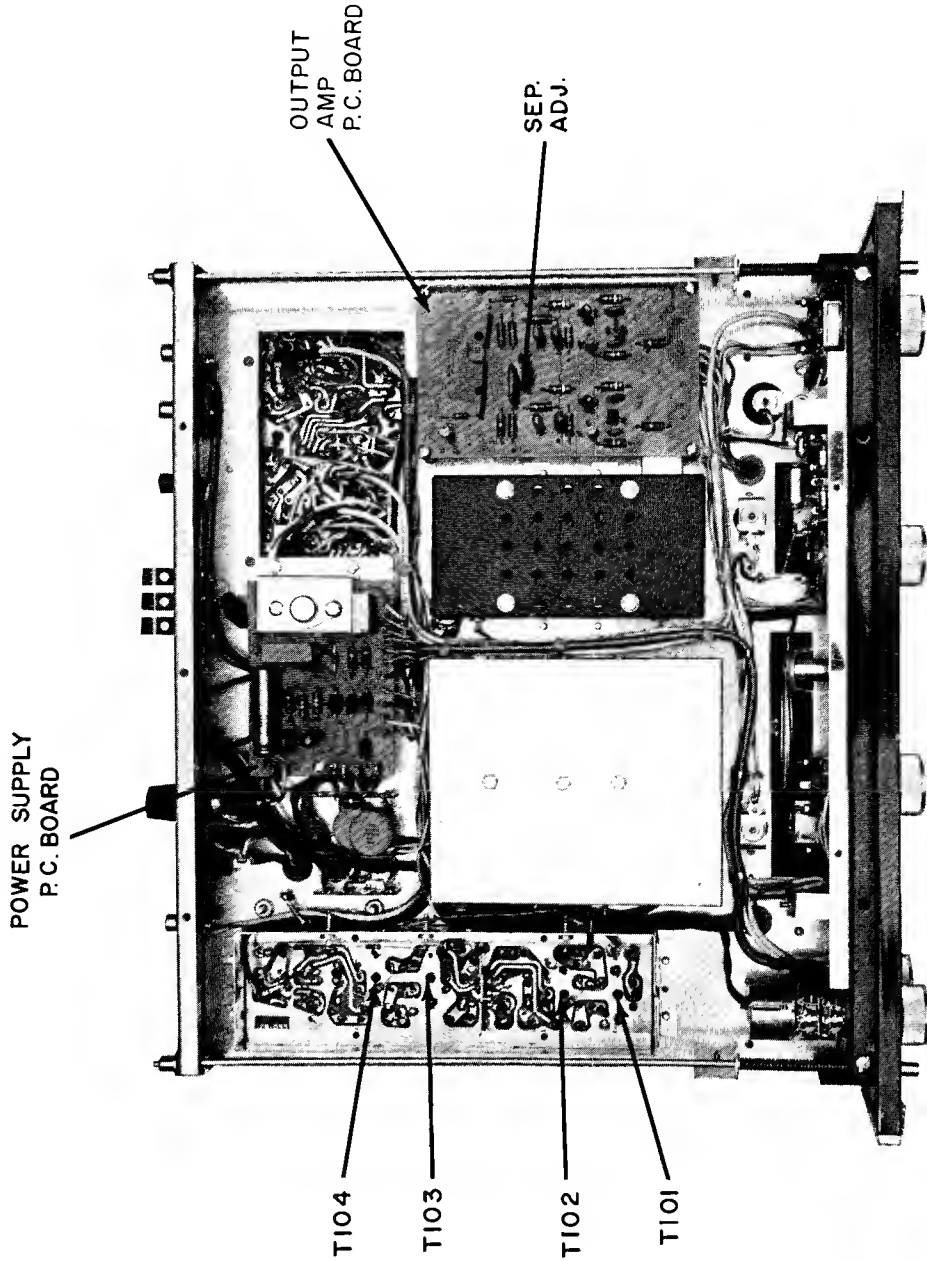

T302 T301 L301 L302 TP3 IF P.C. BOARD

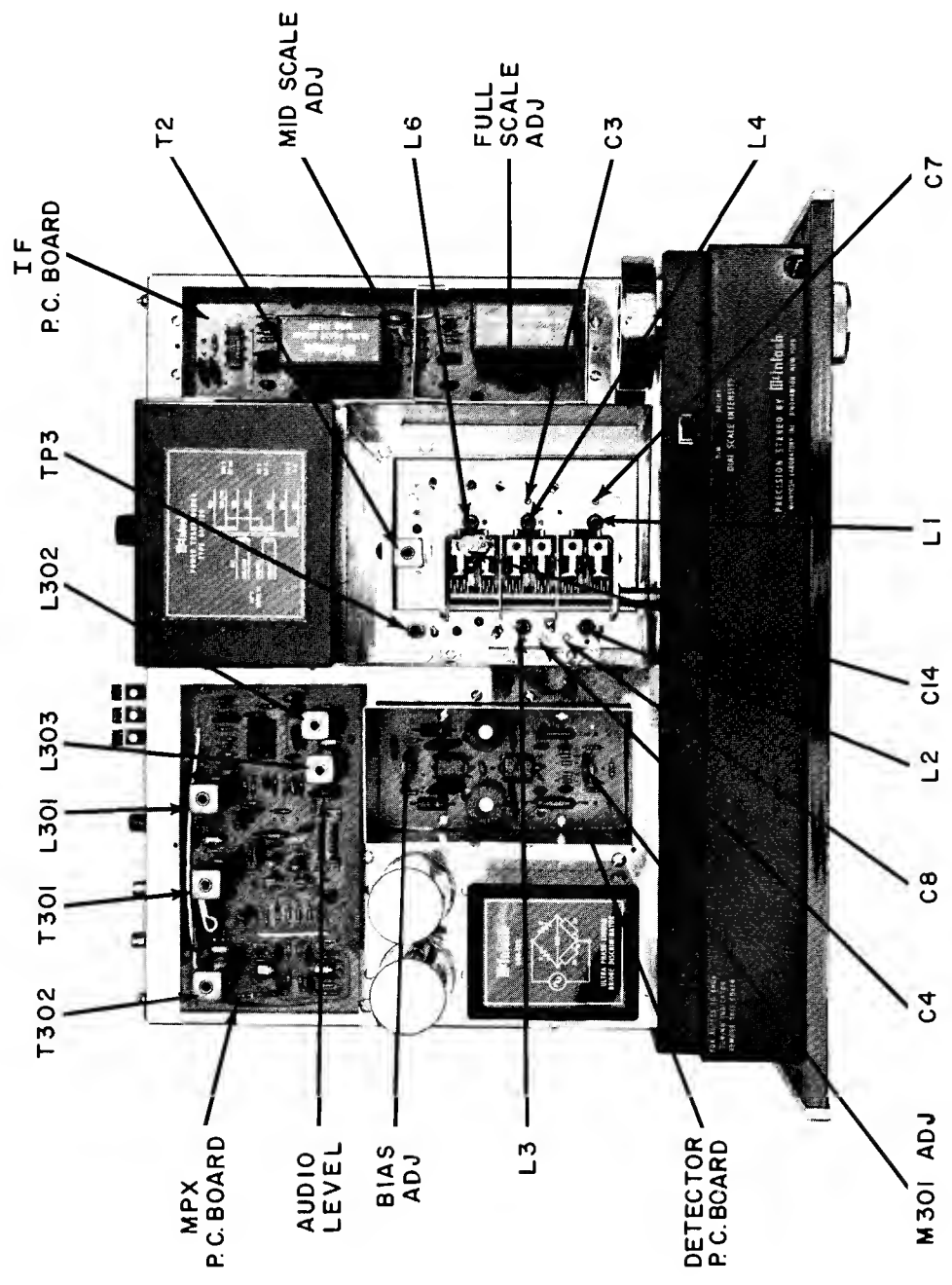
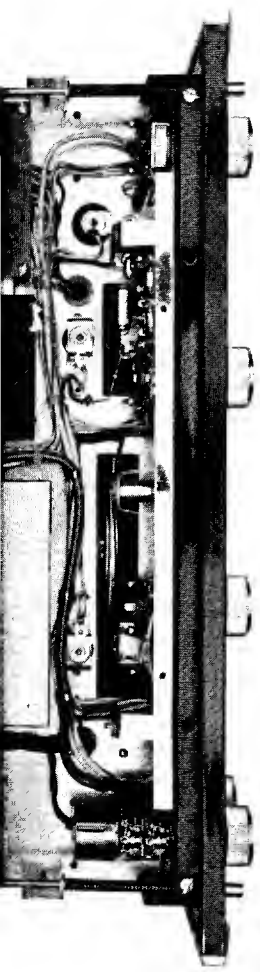

50 AMPERES
 250V
 100% EFFICIENCY
 PRECISION TUNING OF HILDEBRAND
 100% EFFICIENCY OF HILDEBRAND

MR77 ALIGNMENT INSTRUCTIONS

TEST EQUIPMENT REQUIRED

All McIntosh tuners are carefully aligned and tested at the factory using the finest available test equipment. All McIntosh tuners will meet their published specifications when shipped from the factory.

After extensive operation, or servicing, it may be desirable to realign the tuner circuits for best performance. The charts below give complete information on the circuit realignment procedure for the MR77.

The test equipment listed (or its equivalent) is necessary to properly align an MR77. The accuracy of the alignment will be directly related to the accuracy and calibration of the test equipment used.

If the necessary test equipment is not available, alignment should not be attempted. For additional information, contact Customer Service Department, McIntosh Laboratory, Inc., 2 Chambers Street, Binghamton, New York 13903 (telephone 607-723-3512).

Alignment should be done in the following order: FM-MPX

1. FM Signal Generator (Measurement 188 or Sound Technology 1000A)
2. VTVM (RCA WV96C)
3. Multiplex Generator (Radiometer SMG1) or Sound Technology 1000A.
4. 10.7 MHz FM sweep generator (Kay 385 or equivalent). (Not needed if Measurement 275 IF converter is available.)
5. 10.7 MHz Generator (preferably crystal controlled)
6. Oscilloscope (Hewlett-Packard 120B or equivalent)
7. Harmonic Distortion Analyzer (Hewlett-Packard 333A or equivalent)
8. 10.7 MHz ± 75 kHz sweep marker generator.

FM ALIGNMENT

STEP	TUNER DIAL SETTING	SIGNAL GENERATOR			INDICATOR		ADJUST	TEST LIMITS	REMARKS
		FREQ.	COUPLING	MODULATION	TYPE	CONNECTED TO			
1	Point of no interference	10.7 MHz	T0 TP-3	FM ± 200 kHz sweep @ 60 Hz rate	Oscilloscope	TP 1	Top (primary) and bottom (secondary) of T2	Maximum height of 10.7 MHz marker and best symmetry of 10.7 MHz ± 75 kHz markers.	Keep signal generator output low to prevent limiting. TP 1 voltage should not exceed 0.5 volts. Rimo filters do not have a flat-topped response. See typical response curve (Fig. 2). If proper response cannot be obtained go to Step 2. Otherwise go to Step 3. Bottom covers must be on front end and discriminator chassis. Regeneration will distort sweep if either cover is removed.
2	Same	Same	Same	Same	Same	Same	Use standard insulated hex tool. Top and bottom cores of Rimo filters accessible thru bottom of circuit board.	Same	Carefully peak each core for maximum gain at 10.7 MHz (center of IF bandpass), and then touch up all cores for best symmetry to obtain bandpass on opposite page. Do not stagger tune.
3	Same	Same	Same	CW	VTVM	TP 2	M301 adjust R210	Zero DC at TP 2	With tuner horizontal and right side up, M301 should be centered. 10.7 MHz frequency must be precise for this adjustment.
4	Same	Same	Same	FM ± 75 kHz @ 60 Hz rate	Oscilloscope	Fixed audio output jacks	Bias pot R203	Maximum audio output	If output is clipped, reduce audio output by adjusting R317; muting off, stereo filter out.

		output jacks		scope		R205		input		adjusting R317; muting ON, stereo filter out.	
STEP	TUNER DIAL SETTING	FREQ.	SIGNAL GENERATOR	MODULATION	INDICATOR	ADJUST	TEST LIMITS	REMARKS			
			COUPLING		TYPE						
5	106 MHz	106 MHz	300 Ω antenna terminals thru matching network or balun	400 Hz; 75 kHz deviation (Fig. 1)	VTVM to TP 1 and scope to L or R audio output	Oscillator trimmer C14	Maximum negative voltage at TP 1	Keep TP 1 voltage below one volt. Observe signal on scope for reference.			
6	90 MHz	90 MHz	Same	Same	Same	Oscillator Coil L6	Same	Same. Repeat Steps 5 and 6 until dial is accurate.			
7	104 MHz	104 MHz	Same	Same	Same	Adjust C3, C4, and C9	Same	Keep TP 1 voltage below one volt. Reduce signal input as circuits align.			
8	92 MHz	92 MHz	Same	Same	Same	L2, L3, L4	Same	Same			
9	104 MHz	104 MHz	Same	Same	Harmonic distortion analyzer to L or R output	C7	Adjust for minimum noise and distortion at 2.5 μ V input	Noise and distortion should be more than 30 dB down. Noise with no modulation should be more than 40 dB down. Touch up C3, C4, and C9 if necessary.			
10	92 MHz	92 MHz	Same	Same	Same	L1	Same	Touch up L2, L3, and L4 only if necessary.			
11	Repeat Steps 9 and 10 until no further improvement is possible. Always adjust for minimum noise and distortion.										
12	92 MHz	92 MHz	Same	1 kHz at ± 75 kHz deviation or Sound Technology dual sweep	Harmonic distortion analyzer to L or R output or Sound Technology to L or R output	R203	Minimum distortion should be less than 0.2%	A very low distortion FM generator is necessary. Sound Technology 1000A is recommended. Typical MR77 distortion is 0.05% in this test. Minimum distortion should correspond closely to maximum audio output. If Sound Technology 1000A is used, adjust R203 for smoothest horizontal dual-sweep pattern. Refer to Sound Technology manual. Check 1 kHz harmonic distortion.			
13	Same	Same	Same	1 kHz at ± 75 kHz deviation	Oscilloscope connected to L or R output	R210		Reduce signal strength until noise appears on tips of signal. If necessary, adjust R210 so that tuning meter is centered.			
14	Same	Same	Same	Same	With muting in distant position, tuner should mute at approximately 5 μ V in 300 Ω . With muting in local position, tuner should mute at approximately 20 μ V in 300 Ω . Muting thresholds are fixed. These values are typical.						

MULTIPLY DECODER ALIGNMENT

STEP	TUNER DIAL SETTING	FREQ.	SIGNAL GENERATOR		INDICATOR		ADJUST	TEST LIMITS	REMARKS
			COUPLING	MODULATION	TYPE	CONNECTED TO			
1	100 MHz or point of no interference	Same as tuner dial	300 Ω antenna terminals with approximately 1000 μ V signal thru matching	Mono (R = L) 1 kHz 100% modulation	Oscilloscope and AC-VTVM connected to either fixed audio output jack.	R317	2.5V RMS at fixed output jacks	Make sure tuning meter is at zero center. Maximum indication on signal strength meter and center indication on tuning meter should coincide.	

STEP	TUNER DIAL SETTING		SIGNAL GENERATOR		INDICATOR		ADJUST	TEST LIMITS	REMARKS
	FREQ.	COUPLING	MODULATION	TYPE	CONNECTED TO				
1	100 MHz or point of no interference	300Ω antenna terminals with approximately 1000μW signal thru matching network or balun	Mono (R = L) 1 kHz 100% modulation	Oscilloscope and AC-VTVM connected to either fixed audio output jack.	R317	2.5V RMS at fixed output jacks	Make sure tuning meter is at zero center. Maximum indication on signal strength meter and center indication on tuning meter should coincide.		
2	Same	Same	67kHz and 53kHz at ±75kHz deviation	Pin 13 of I _c on stereo decoder board	L302 and L303	Adjust L302 for maximum 53kHz, L303 for minimum 67kHz. Do not attempt to detect 67kHz at tuner output jacks. Ground scope probe close to multiplex board. Repeat adjustments of L302 and L303 until optimum condition is reached.			
3	Same	Same	19 kHz pilot	Base of Q305	L301 and T301	For maximum amplitude	Decrease pilot level, if necessary, so that 19 kHz circuits do not limit or saturate.		
4	Same	Same	Same	T302 Pin 1 or 2	T302 top and bottom	Maximum amplitude	Use normal (9%) pilot level. Remove scope probe before going to Step 5.		
5	Same	Same	Stereo 1 kHz (100% modulation) left only pilot level normal and on	Right fixed output jack	T302 bottom (sec) and R4	40dB separation or more	First set R401 to maximum resistance. (Fully clockwise looking from front of tuner.) Adjust T302 bottom tuning slug (sec) for minimum output on right (undesired) channel. Then adjust R401 for maximum separation. Repeat the adjustment of T302 bottom and R401 until maximum separation is obtained. Then reverse channels and measure left channel separation.		
6	Same	Same	Stereo pilot carrier modulation only	L or R output jack		Less than 50MV of residual	With modulation off but pilot on. (NOTE: Stereo generator must have low spurious output.)		

FIG. 2 TYPICAL IF RESPONSE CURVE

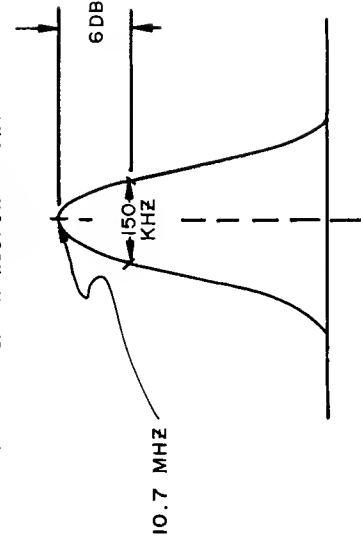
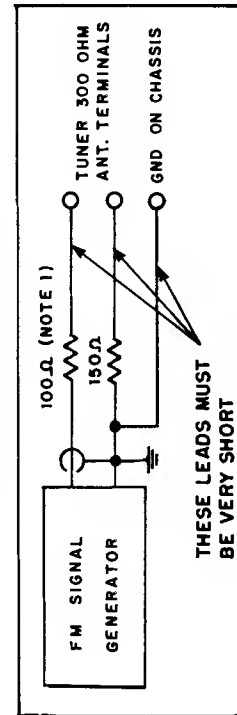

FIG. 1 ANTENNA MATCHING NETWORK



REPLACEMENT PARTS

All parts not listed are common items obtainable from radio parts jobbers.

Replacement parts may be obtained when ordered by PART NUMBER from:

McIntosh Laboratory, Inc.
Customer Service Department
2 Chambers Street
Binghamton, New York 13903
(telephone 607-723-3512)

CAPACITORS

Symbol Number	Description	Part Number
C12,13	Silver Mica 270pF 20V	063-010
C304	Tant. Elect. 10μF 35V	066-239
C306	Elect. 22μF 25V	066-240
C308	Tant. Elect. 10μF 35V	066-239
C309	Polystyrene 2700pF	064-239
C310	Tant. Elect. 10μF 35V	066-149
C311	Polystyrene 1500pF	064-092
C314	Tant. Elect. 10μF 35V	066-239
C316	Tant. Elect. 10μF 35V	066-239
C323	Elect. 1μF 50V	066-242
C325	Elect. 22μF 25V	066-240
C326,327	Polystyrene 4700pF	064-091
C328	Tant. Elect. 10μF 35V	066-239
C331	Polystyrene .0033μF	064-090
C334	Polystyrene .0033μF	064-090
C335	Polystyrene 4700pF	064-091
C336,337	Polystyrene 2700pF	064-093
C338	Polystyrene .033μF	064-089
C404,405	Elect. 22μF 25V	066-240
C408,409	Tant. Elect. 10μF 35V	066-239
C503	Elect. 200μF 50V	066-154
C504	Elect. 5/300/150/1000 200/50/50/30	066-155
C505	Mylar .22μF 250V	064-068
C506	Elect. 150pF 63V	066-205
C507	Elect. 47μF 16V	066-182

DIODES

D101,102	Ge. signal diode	070-003
D103,104	Ge. signal diode	070-003
D201,202	Si. signal diode	070-022
D203,204	Si. signal diode	070-047
D301,302	Si. signal diode	070-047
D303,304	Si. signal diode	070-047
D305,306	Si. signal diode	070-047

D308	Si. signal diode	070-047
D309,310	Si. signal diode	070-047
D311	Si. signal diode	070-047
D501,502	Si. rectifier diode	070-031
D503,504	Si. rectifier diode	070-031
D505	Zener diode 24V	070-065

CHOKES

L1	Antenna coil	122-087
L2	RF coil: input	122-088
L3	Mixer coil	122-090
L4	RF coil: output	122-089
L5	Choke 1.5μH	122-032
L6	Oscillator coil	122-117
L7	Choke 1.5μH	122-032
L8	Choke 75μH	122-013
L201,202	Choke 75μH	122-013
L301	Filter coil (19kHz)	122-094
L302,303	Filter coil (SCA)	122-093
L304	Choke 1MH	122-092
L501	Choke 2.2μH	122-001

TRANSISTORS

Q1	Si. NPN transistor	132-066
Q2	Si. Junction F.E.T.	132-097
Q3	Si. Junction F.E.T.	132-068
Q4	Si. NPN transistor	132-087
Q201,202	Si. NPN transistor	132-066
Q301	Si. NPN transistor	132-092
Q302	Si. NPN transistor	132-094
Q303	Si. NPN transistor	132-092
Q304	Si. NPN transistor	132-094
Q305	Si. NPN transistor	132-094
Q306	Si. NPN transistor	132-042
Q401,402	Si. PNP transistor	132-096
Q403,404	Si. NPN transistor	132-093
Q405,406	Si. NPN transistor	132-052
Q407	Si. NPN transistor	132-054
Q501	Si. NPN transistor	132-065
Q502	Si. PNP transistor	132-094

FUSES

F501	Fuse .5A slo-blo	089-020
------	------------------	---------

POTENTIOMETERS

R102	Full scale adj.	134-260
R106	Mid scale adj.	134-260

R203

R210

R317

R401

R418

R205,206

R207,208

R333,334

R338,339

R503

R508

R509

S301

S302

S303

S502

T1

T2

T101

T102

T103

T104

T201

T202

T203

T301

T302

T501

V401

IC1

IC101,102

IC301A,B

M101

M301

R203	Bias adj.	134-265
R210	M301 adj.	134-265
R317	Audio level	134-258
R401	Separation adj.	134-260
R418	Volume control	134-217

RESISTORS

R205,206	Wirewound	220 Ω	5%	1W	139-076
R207,208	Film	56.2 Ω	1%	1W	144-014
R333,334	Film	33k	1%	1W	144-015
R338,339	Film	33k	1%	1W	144-015
R503	Wirewound	15 Ω	10%	5W	139-041
R508	Wirewound	2 Ω	10%	5W	139-005
R509	Wirewound	1.8 Ω	10%	1W	139-077

SWITCHES

S301	Mode selector	146-138
S302	Muting switch	146-138
S303	Stereo filter	146-137
S502	Dial scale intensity	148-023

TRANSFORMERS

T1	Balun	043-226
T2	Mixer	162-051
T101	1st IF filter	162-053
T102	1st IF filter	162-052
T103	2nd IF filter	162-053
T104	2nd IF filter	162-052
T201	Driver transformer	044-121
T202	Output transformer	044-121
T203	FM detector	044-123
T301	RF transformer (19 kHz)	162-055
T302	RF transformer (38 kHz)	162-054
T501	Power transformer	044-120

TUBES

V401	6HU6	165-025
------	------	---------

INTEGRATED CIRCUITS

IC1	Integrated circuit	133-005
IC101,102	Integrated circuit	133-002
IC301A,B	Integrated circuit	133-004

METERS

M101	Signal strength meter	124-005
M301	Tuning meter	124-006

RELAY

K301	Reed relay	087-008
------	------------	---------

LAMPS

#1847	(Meter lamp)	058-008
#1866	(Front panel)	058-014
#1828	(MPX lamp)	058-027
	Festoon lamp (Dial glass)	058-032

FRONT PANEL & TRIM

	Front panel	044-109
	Front panel end caps	018-120
	Tuning knob	044-122
	Muting control knob	044-372
	Mode selector knob	044-372
	Stereo filter knob	044-372
	Volume control knob	044-372

MOUNTING SYSTEM

	Shelf bracket (right)	043-592
	Shelf bracket (left)	043-593
	Mounting template #100	038-179
	Hardware package	043-446

MISCELLANEOUS ITEMS

	FM dipole antenna	170-033
	Dial glass	044-164
	Pointer	043-876
	Dial cord (complete)	044-226
	Fuseholder	178-001
	AC power cord	170-021
	Shipping carton	044-238
	Owners manual	038-912
	Plastic feet	017-041
	Push terminal (antenna)	074-033
	Audio cable (6')	170-015

FL1 - AUDIO FILTER 180-019