

McIntosh

MR 74

AM/FM TUNER

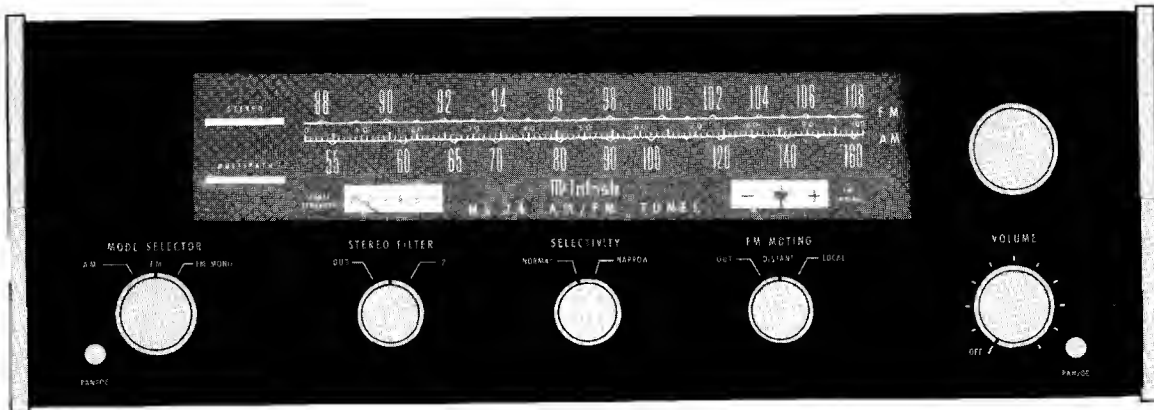

SERVICE INFORMATION

STARTING WITH SERIAL NO. AC1001

McINTOSH LABORATORY INC. 2 CHAMBERS STREET BINGHAMTON, NEW YORK

MR 74

ELECTRICAL SPECIFICATIONS

AM TUNER SECTION

SENSITIVITY

75 μ V IHF (external ant.)

SIGNAL TO NOISE RATIO

45 dB IHF minimum; 55 dB at 100% modulation.

HARMONIC DISTORTION

Does not exceed 1% at 30% modulation.

SELECTIVITY, ADJACENT CHANNEL

35 dB minimum IHF in "NORMAL" Position.
45 dB minimum IHF in "NARROW" Position.

IMAGE REJECTION

65 dB minimum 540 kHz - 1600 kHz.

FREQUENCY RESPONSE

3.5 kHz - 6 dB, "NORMAL" Position.
2.1 kHz - 6 dB, "NARROW" Position.

FM TUNER SECTION

USEABLE SENSITIVITY

2.5 microvolts at 100% modulation (± 75 kHz deviation) for 3% total noise and harmonic distortion IHF.

SIGNAL TO NOISE RATIO

70 dB below 100% modulation.

CAPTURE RATIO

1.5 dB minimum.

HARMONIC DISTORTION

Mono: Does not exceed 0.3% at 100% modulation ± 75 kHz deviation.

Stereo: Does not exceed 0.7%.

AUDIO FREQUENCY RESPONSE

± 1 dB 20 Hz to 15,000 Hz with standard de-emphasis (75 μ sec.) and 19,000 Hz pilot filter.

SELECTIVITY

ADJACENT CHANNEL:

6 dB minimum IHF in "NORMAL" Position.
15 dB minimum IHF in "NARROW" Position.

ALTERNATE CHANNEL:

58 dB minimum IHF in "NORMAL" Position.
88 dB minimum IHF in "NARROW" Position.

SPURIOUS REJECTION

90 dB IHF minimum.

IMAGE REJECTION

95 dB minimum, 88 MHz - 108 MHz.

STEREO SEPARATION

35 dB at 1,000 Hz.

SCA FILTER

50 dB rejection from 67 kHz to 74 kHz.
275 dB per octave slope.

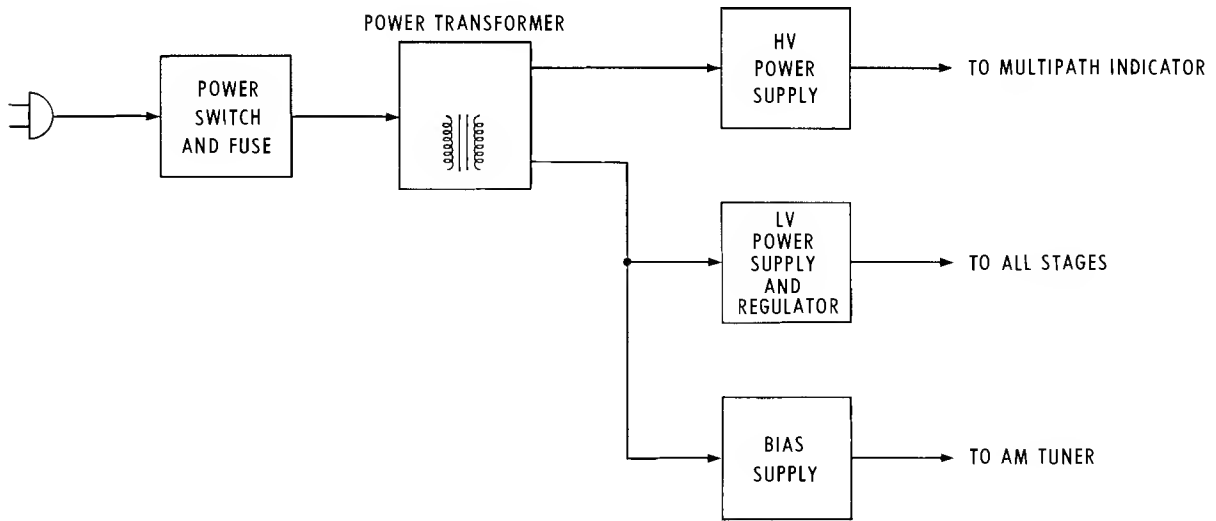
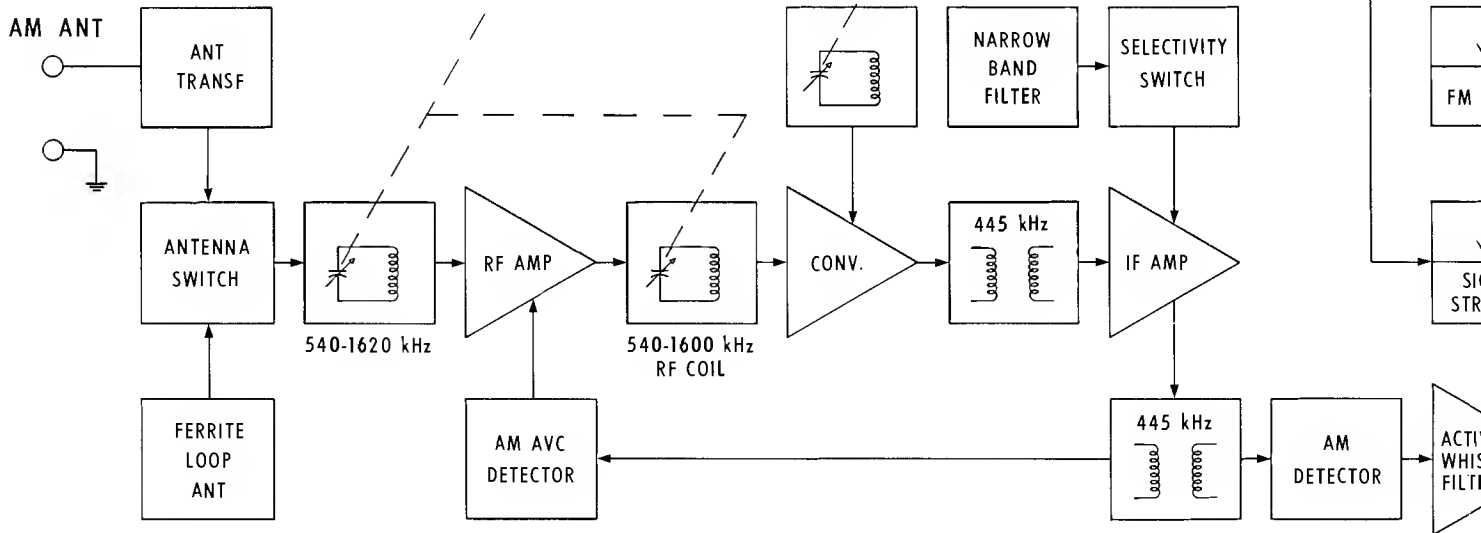
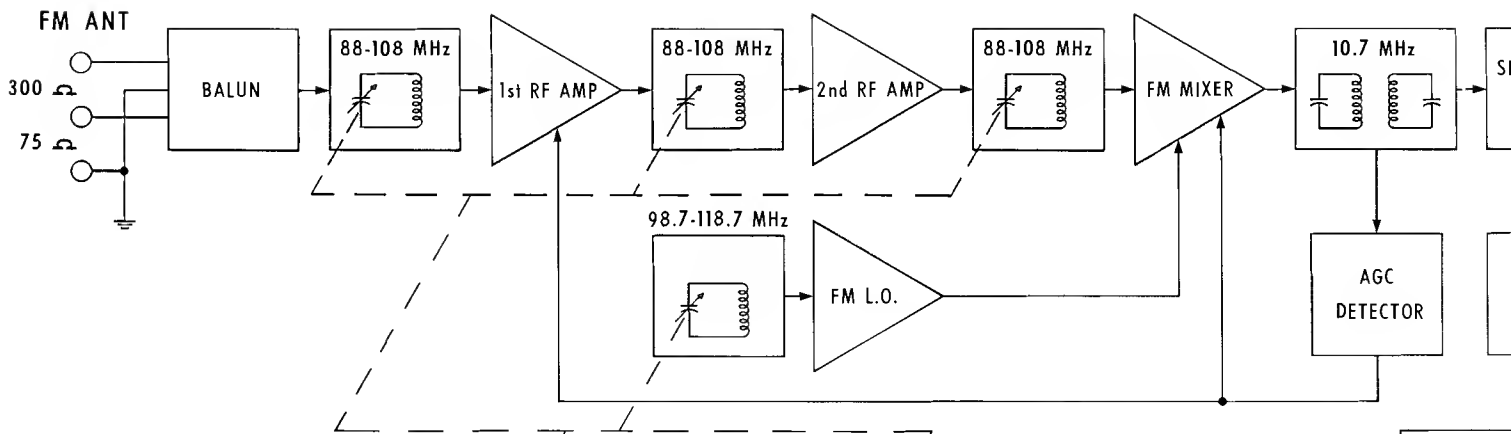

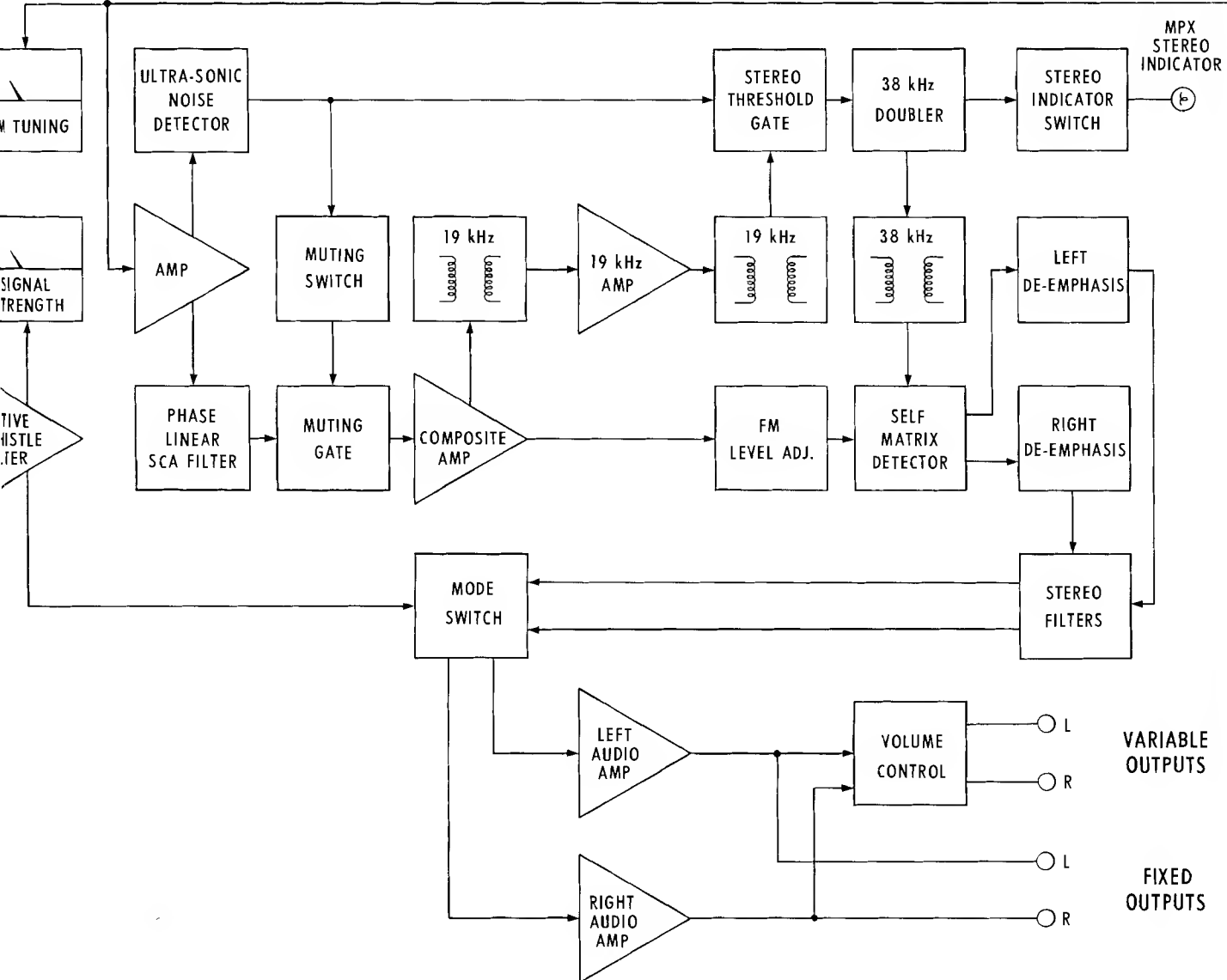
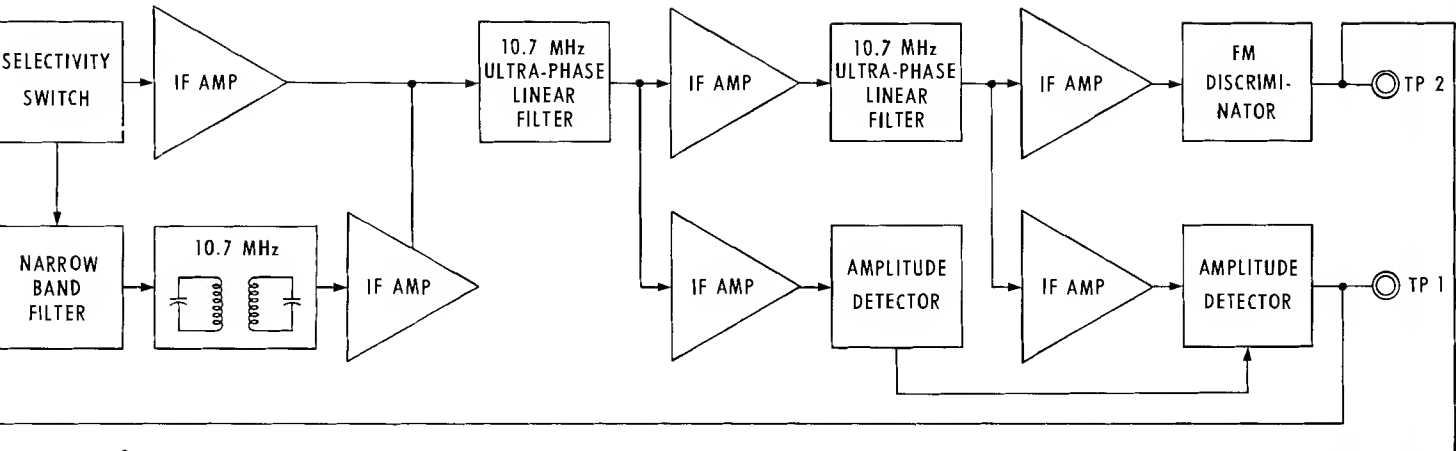

SCHEMATIC NOTES

Unless otherwise specified: Resistance values are in ohms, 1/4 watt, and 10% tolerance; capacitance values smaller than 1 are in microfarads (μF); capacitance values greater than 1 are in picofarads (pF); inductors are in microhenries (μH).

Printed circuit board components are outlined on the schematics by dotted lines. The circled numbers around the dotted lines correspond to the numbers on the PC Board layouts.

The heavy lines on the schematics denote the primary signal path.

The terminal numbering of rotary switches is for reference only.

All voltages indicated on the schematics are measured under the following conditions:

- a. Use of an 11 megohm input impedance VTVM.
- b. All voltages $\pm 10\%$ with respect to chassis ground.
- c. No signal at input or antenna terminals.
- d. AC input at 120 volts, 50/60 Hz.
- e. Front panel controls at:

Tuning indicator	100 MHz (no signal)
Volume	Fully CCW
Mode	AM (to measure AM section) FM (to measure FM section)
Muting	Out
Stereo filter	Out
Panel Lights	Bright
Selectivity	Normal
- f. Voltages shown in rectangles are measured with selectivity switch in the "Narrow" position.

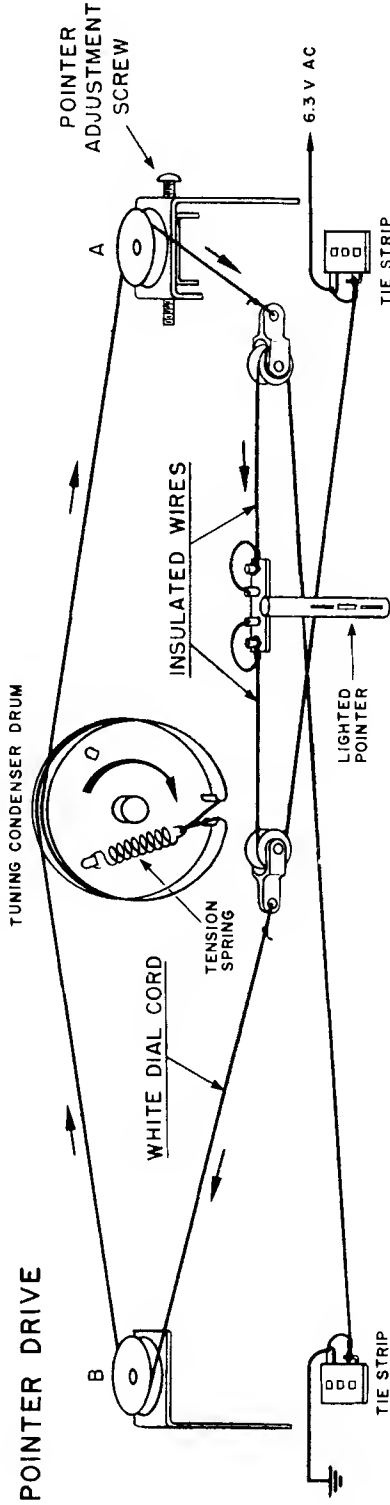

Step 1 Before stringing unit, turn pointer adjustment screw until pulley "A" is in the center of its travel.

Step 2 String unit as shown.

Step 3 After stringing unit, turn tuning shaft until pointer is as far to the left as it will go. Turn the pointer adjustment screw until the pointer coincides with the zero bar of the logging scale.

Step 4 Turn the tuning knob making the pointer move back and forth from one end of the dial scale to the other. Return pointer to the far left end, if necessary, re-adjust pointer position.

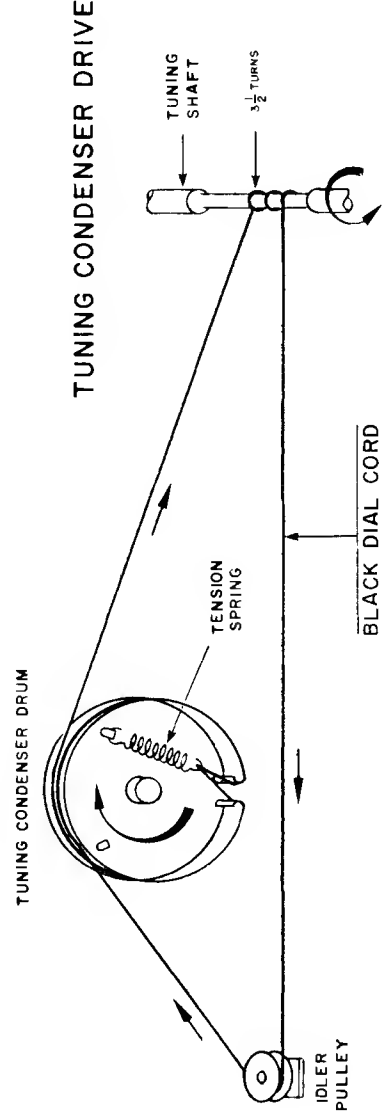

DIAL CORD SEQUENCE

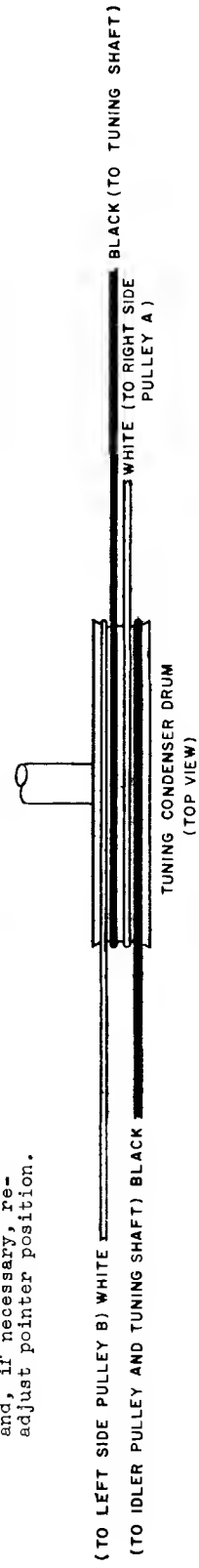

POINTER DIAL STRINGING

IF PC BOARD 044-277

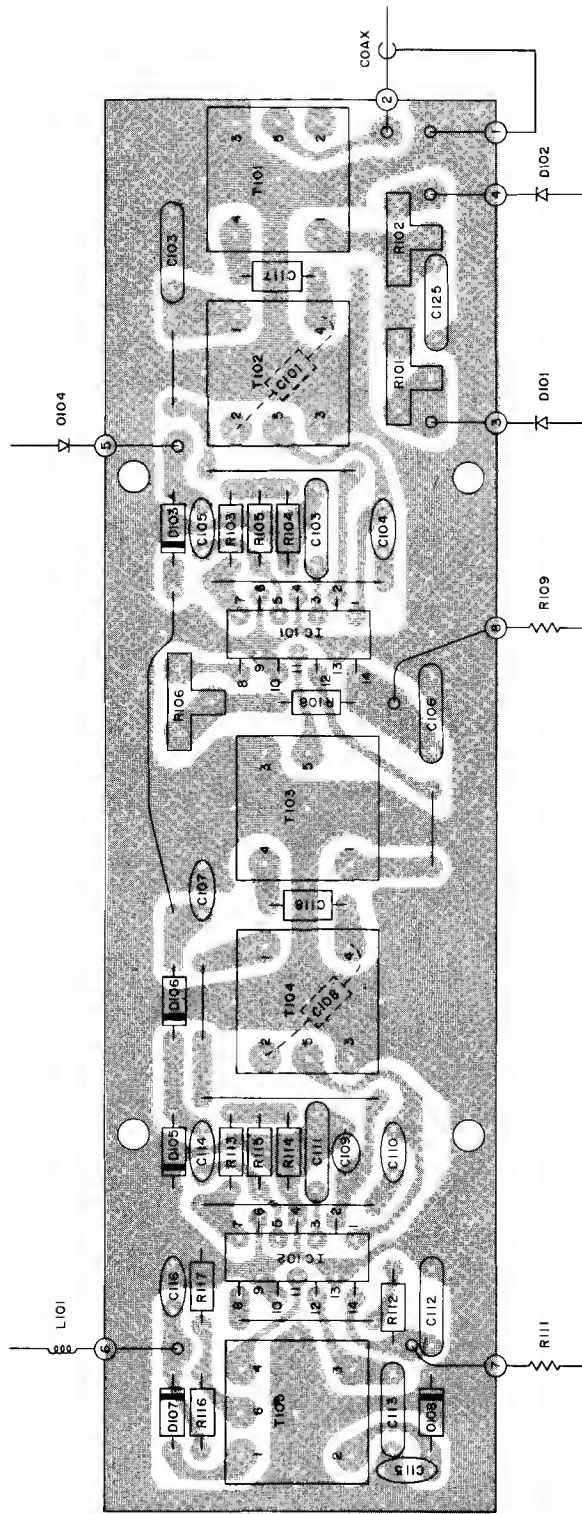

RF CHASSIS

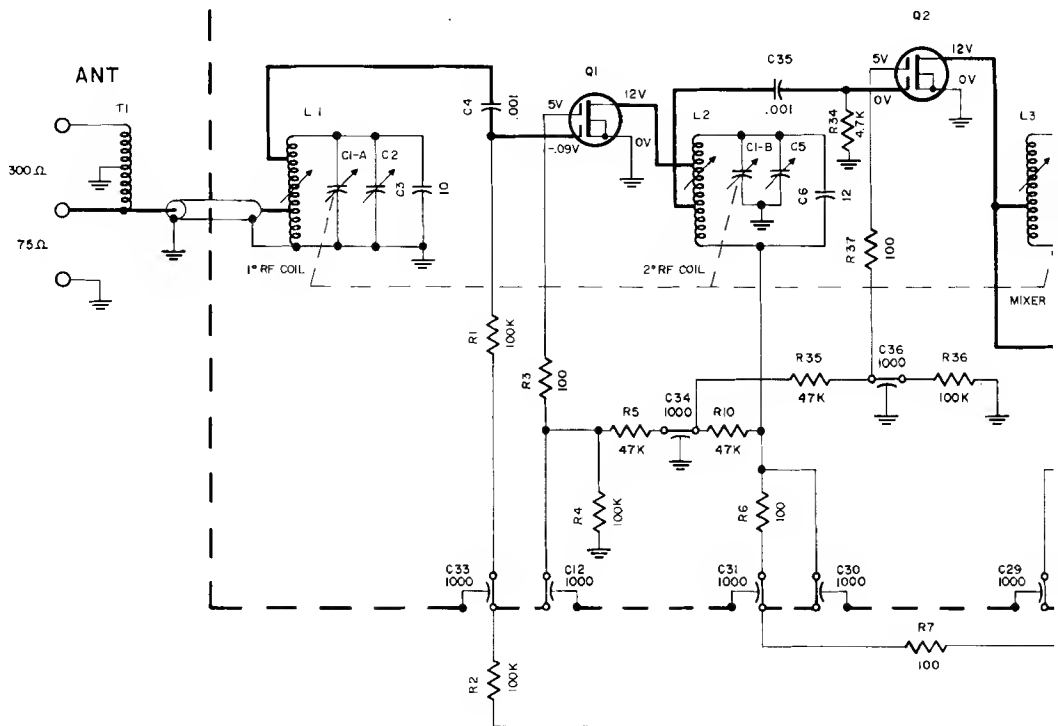

IF CHASSIS

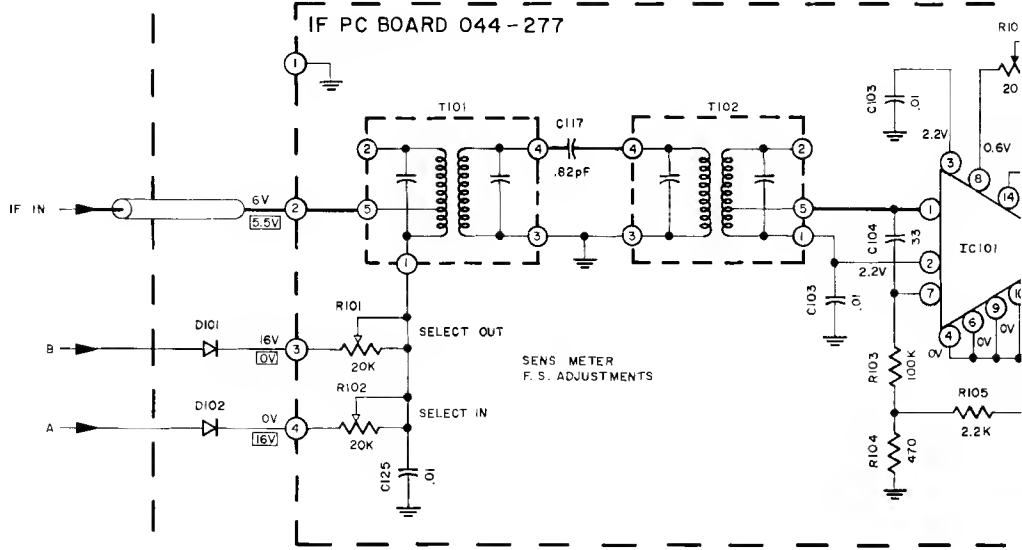

LO & MIXER PC BOARD 044-292

VARIABLE SELECT PC BOARD 044-290

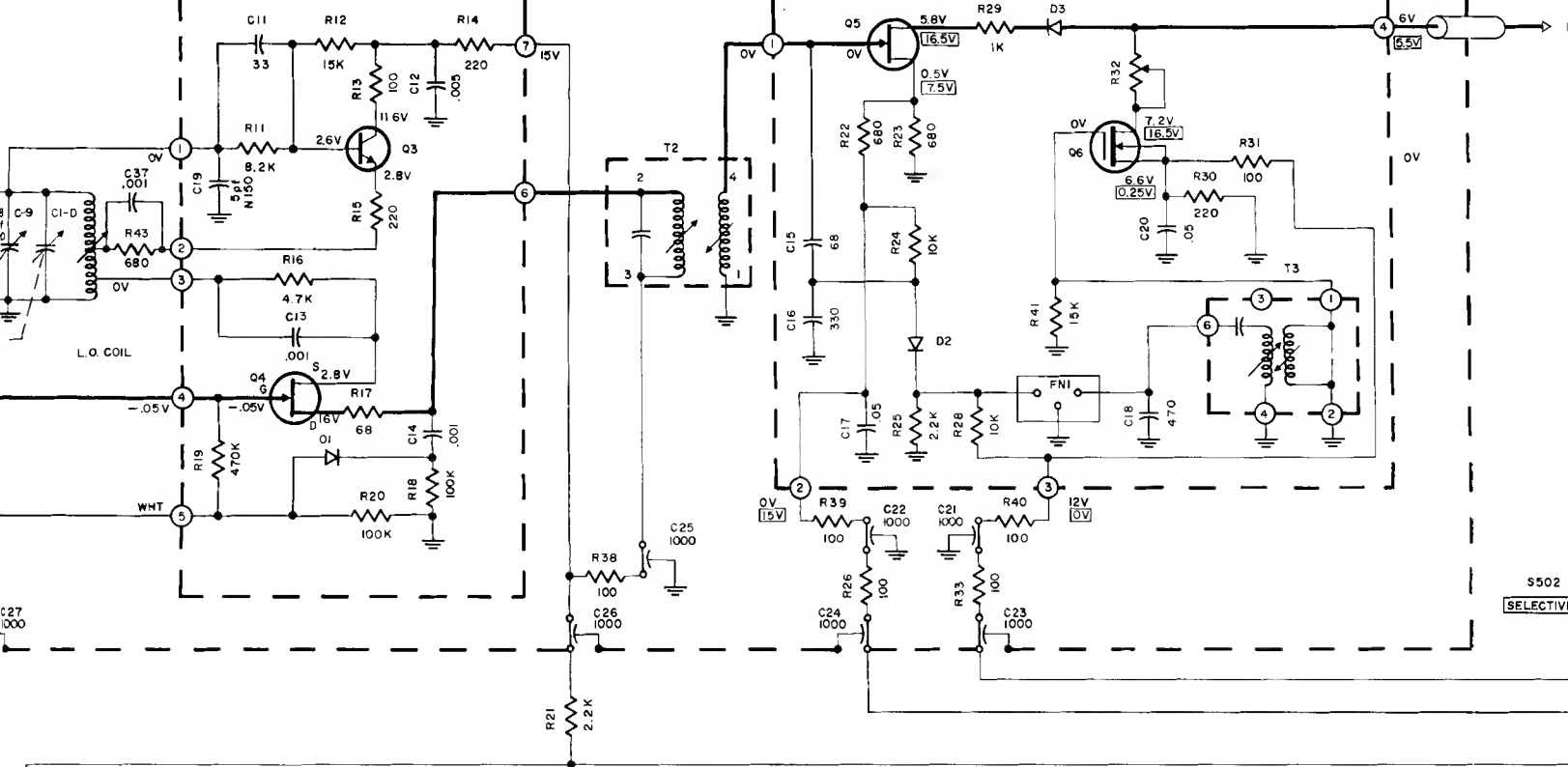

S502
SELECTIVE

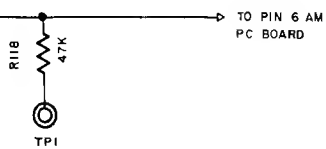
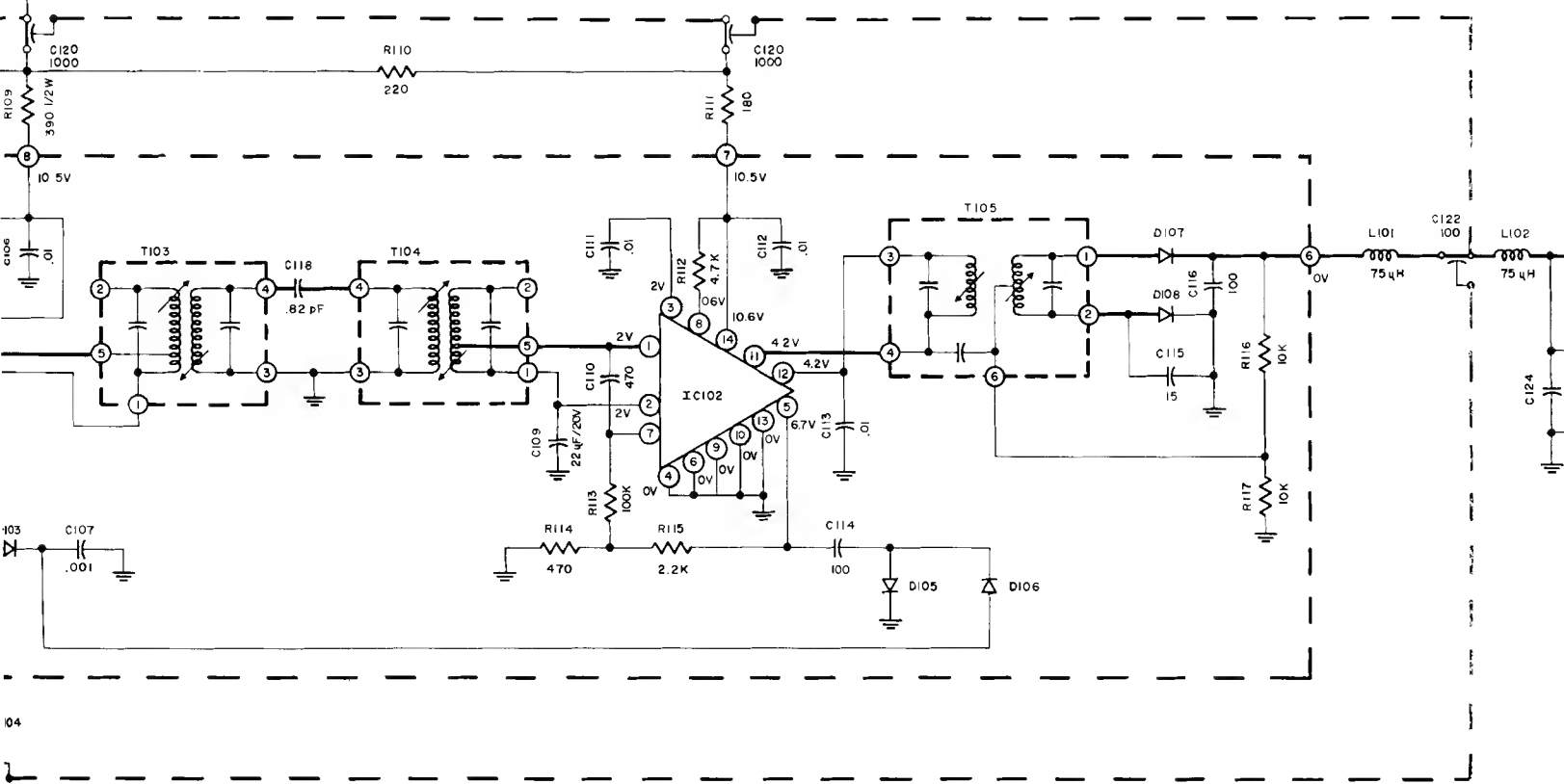

FM TUN

MR 74

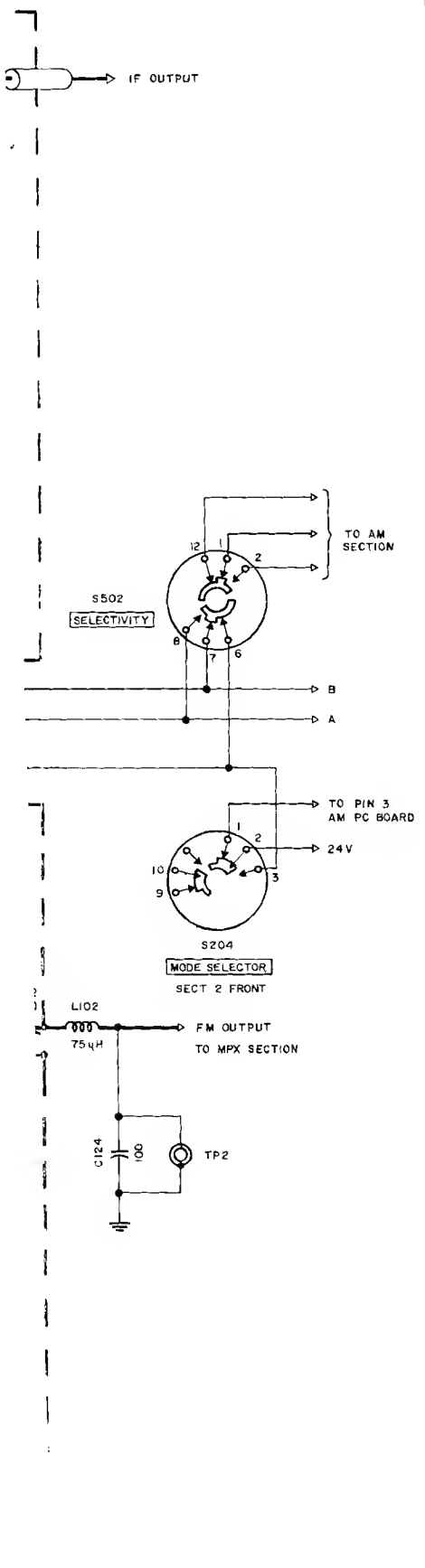

TUNER SECTION

154-522

SELECTIVITY PC BOARD 044-290

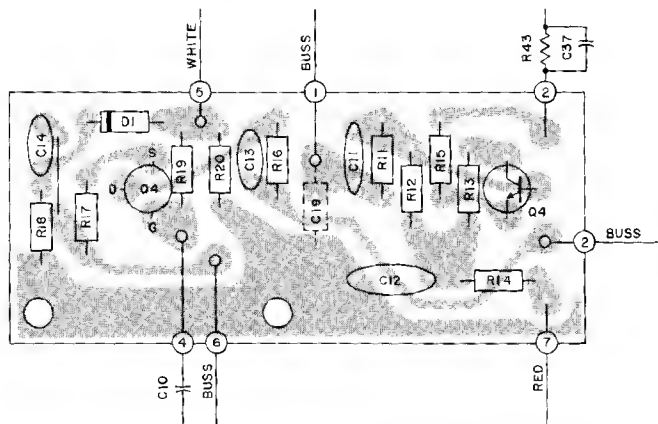
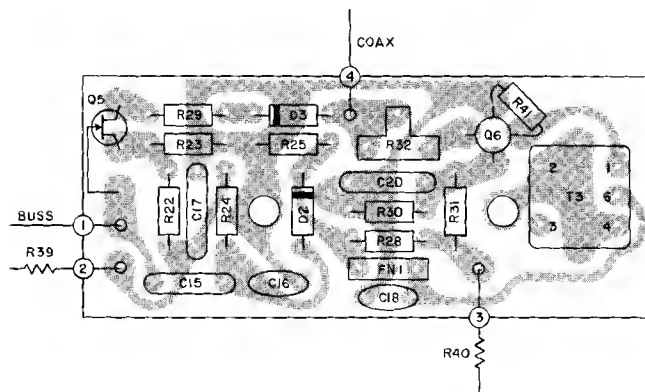

MIXER & LOCAL OSCILLATOR PC BOARD 044-292

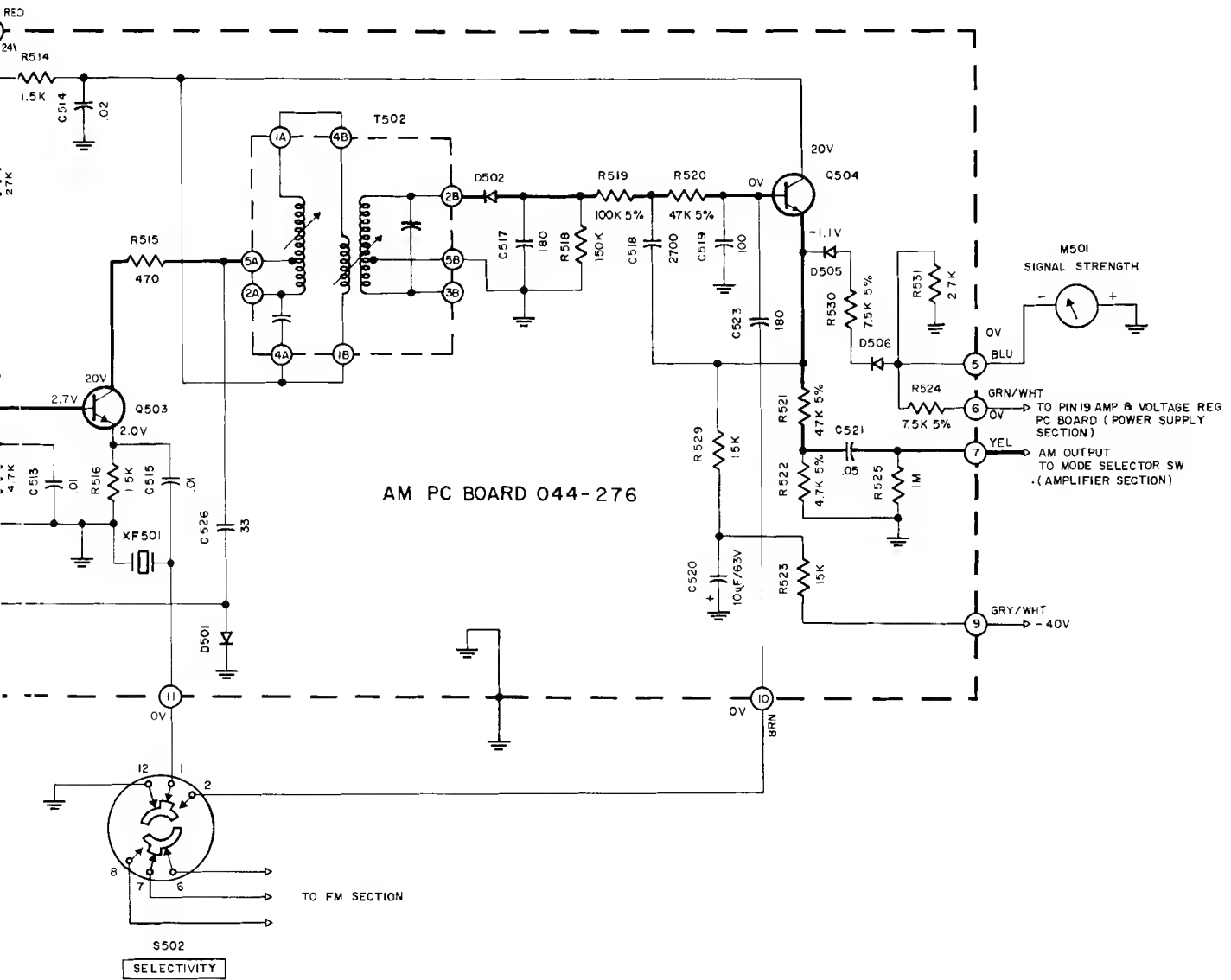

AM PC BOARD 044-276

AM SECTION

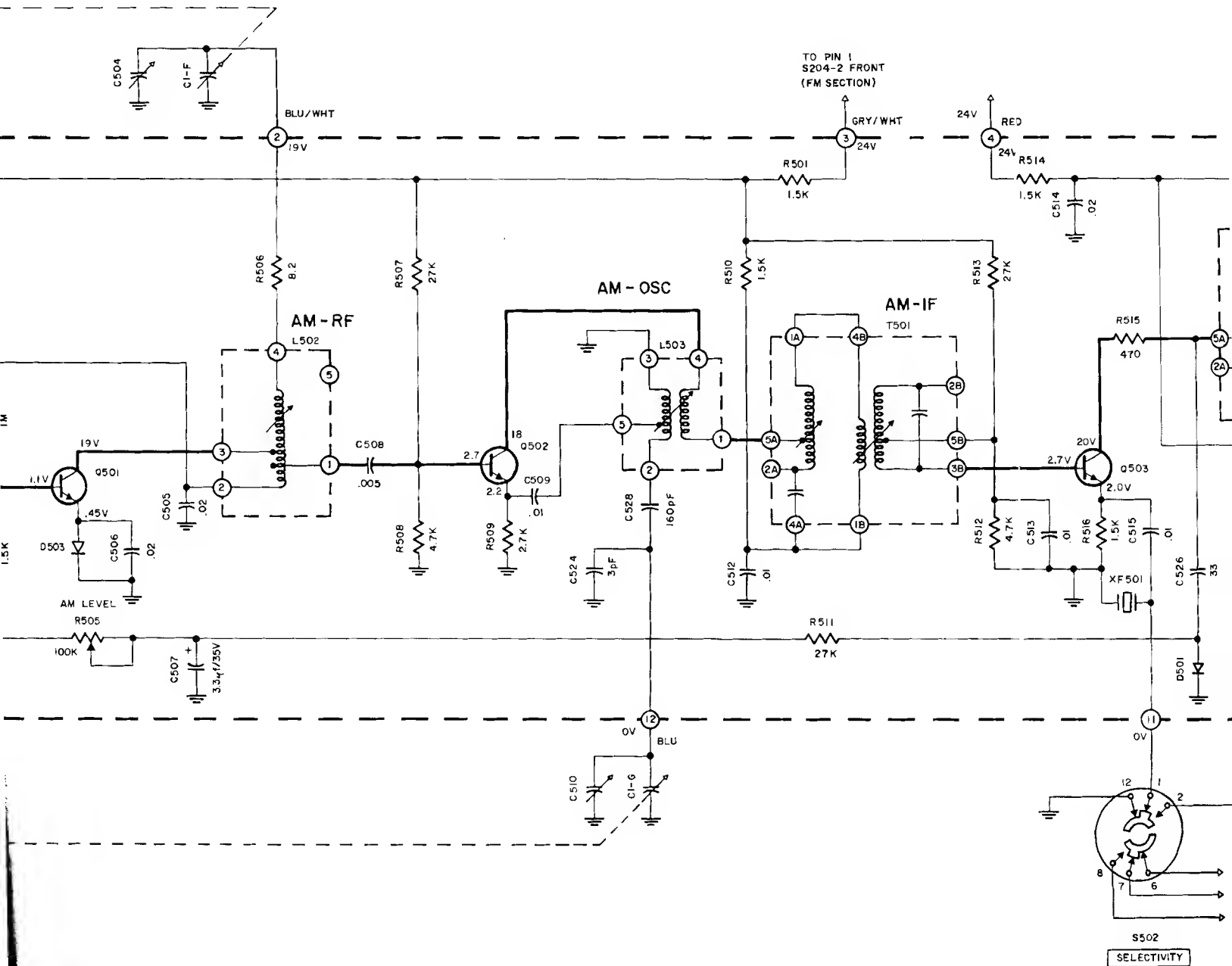

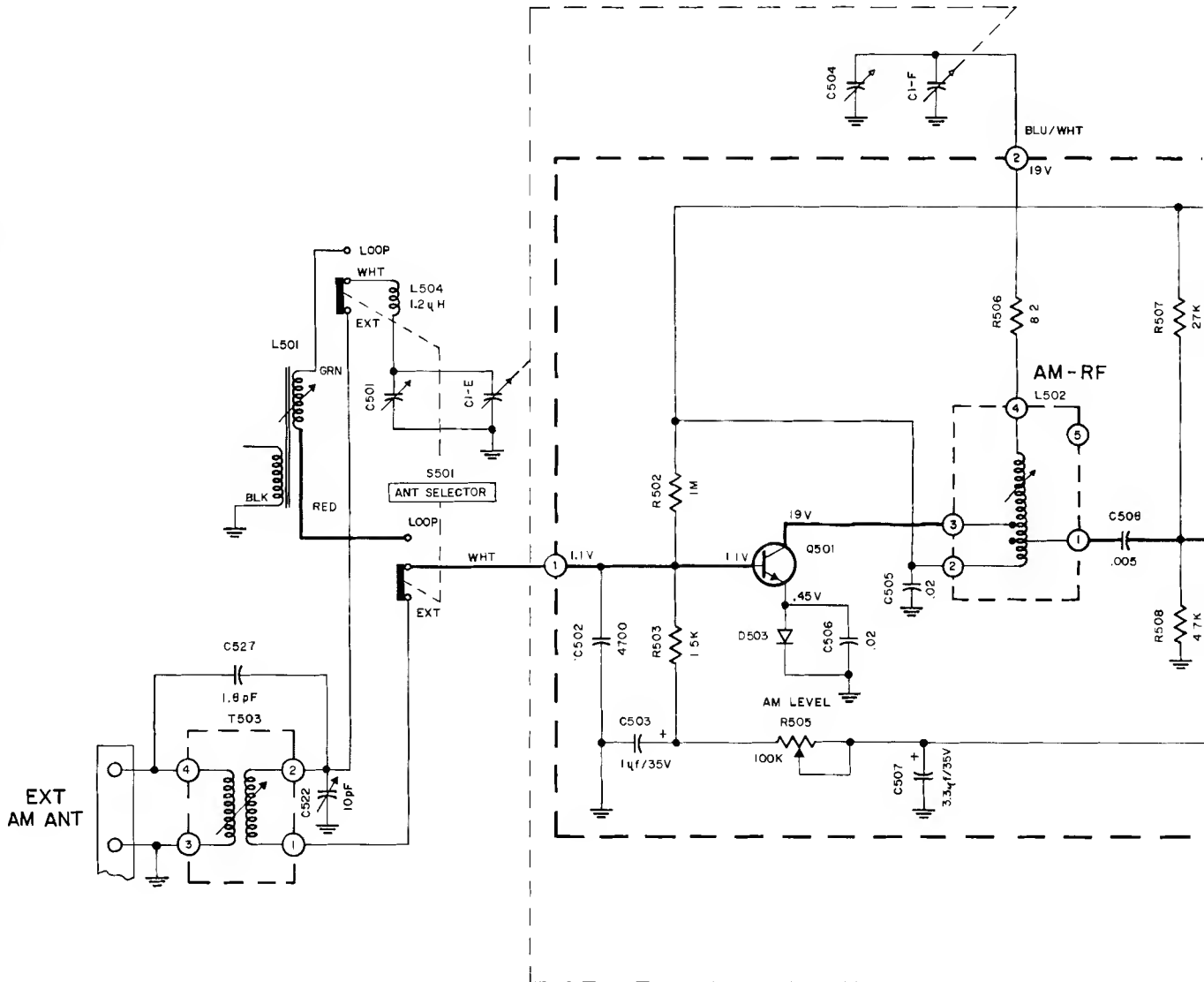

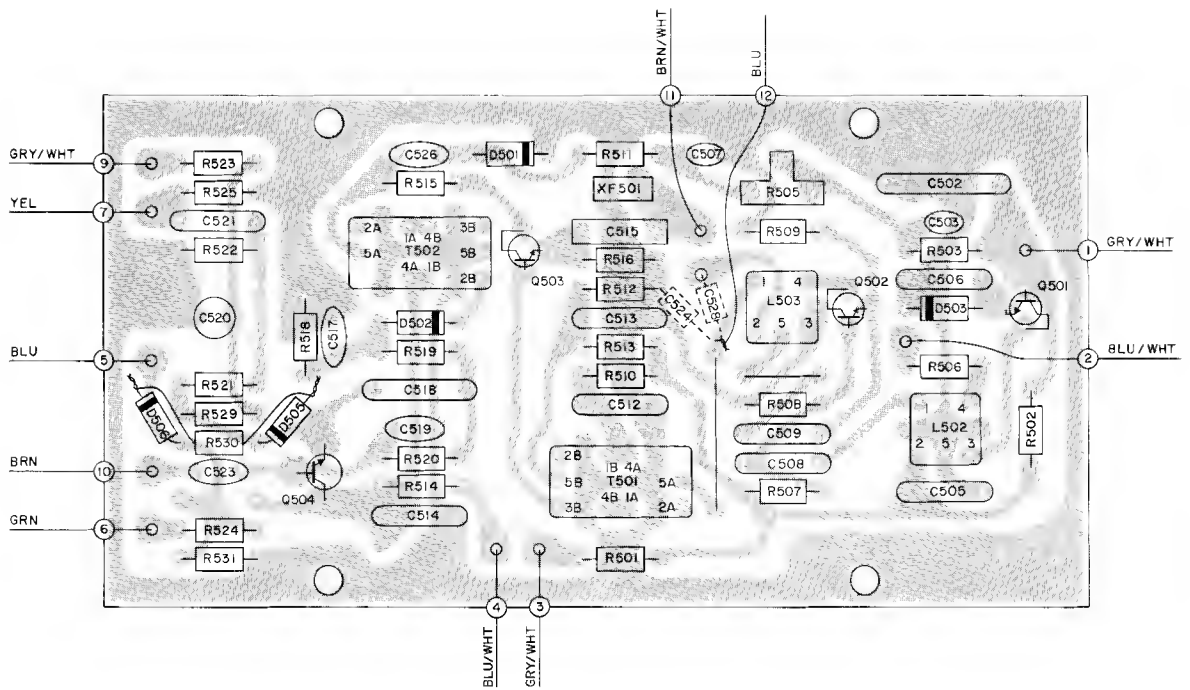

AM PC BOARD 044-276

MPX PC BOARD 044-299

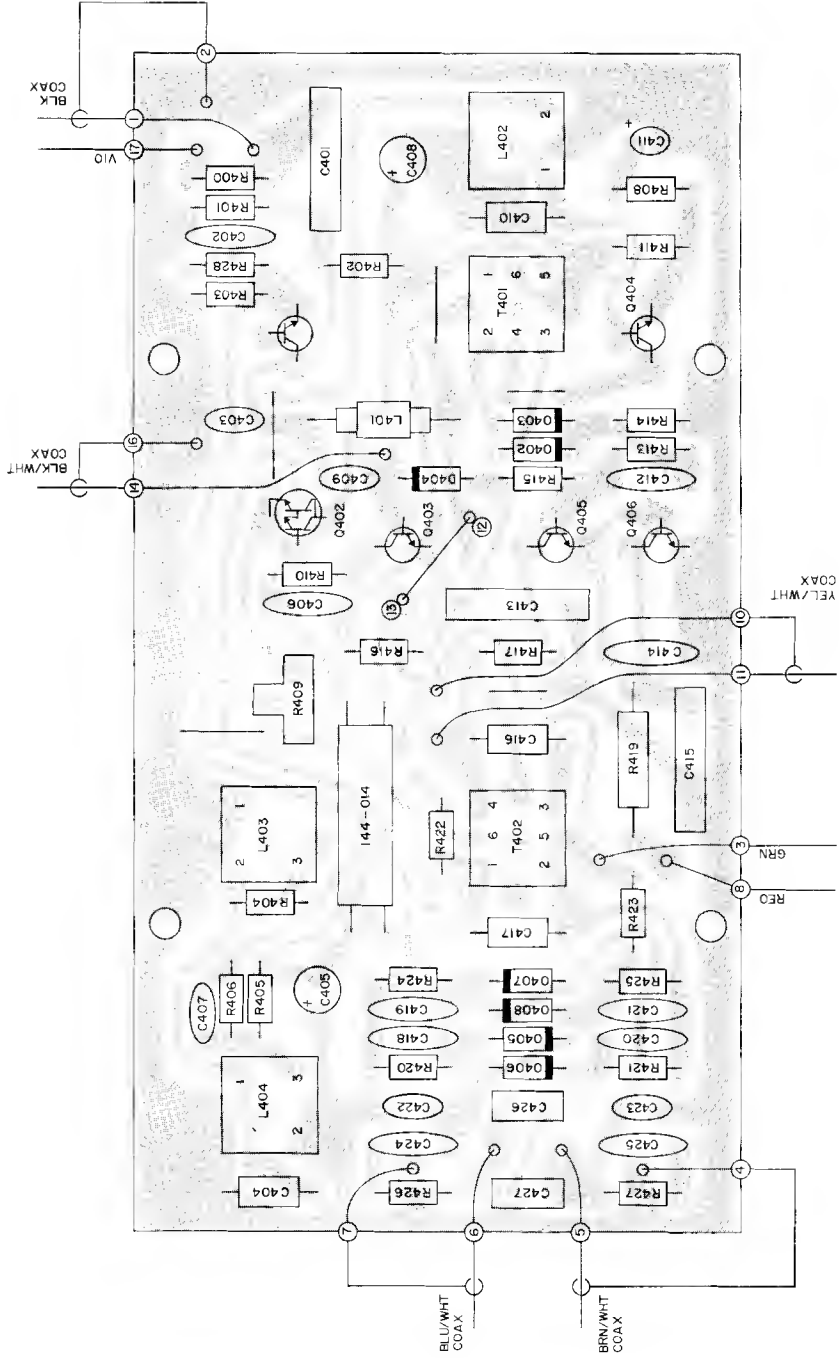

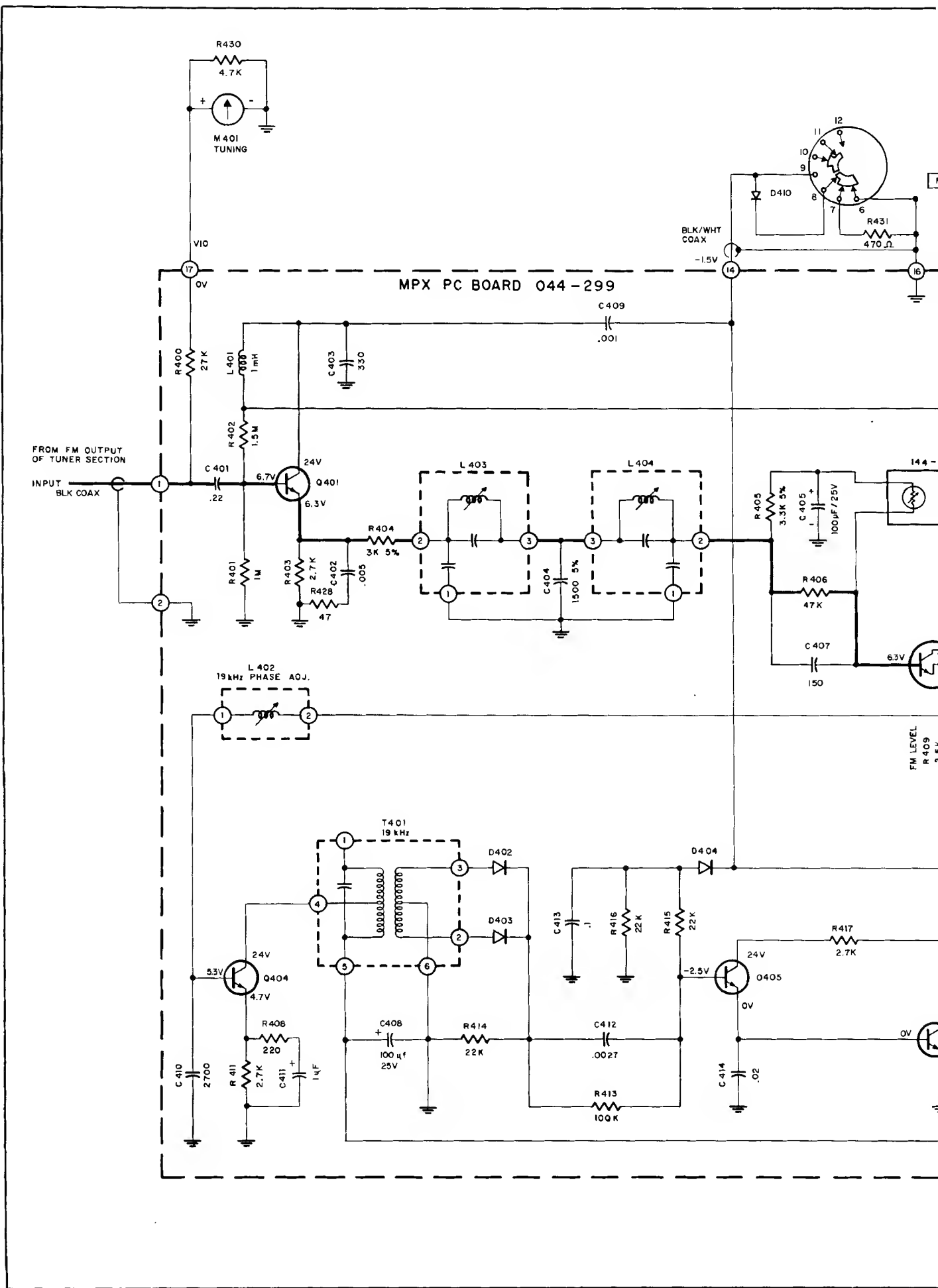

MPX SECTION

MR 74

154 - 520

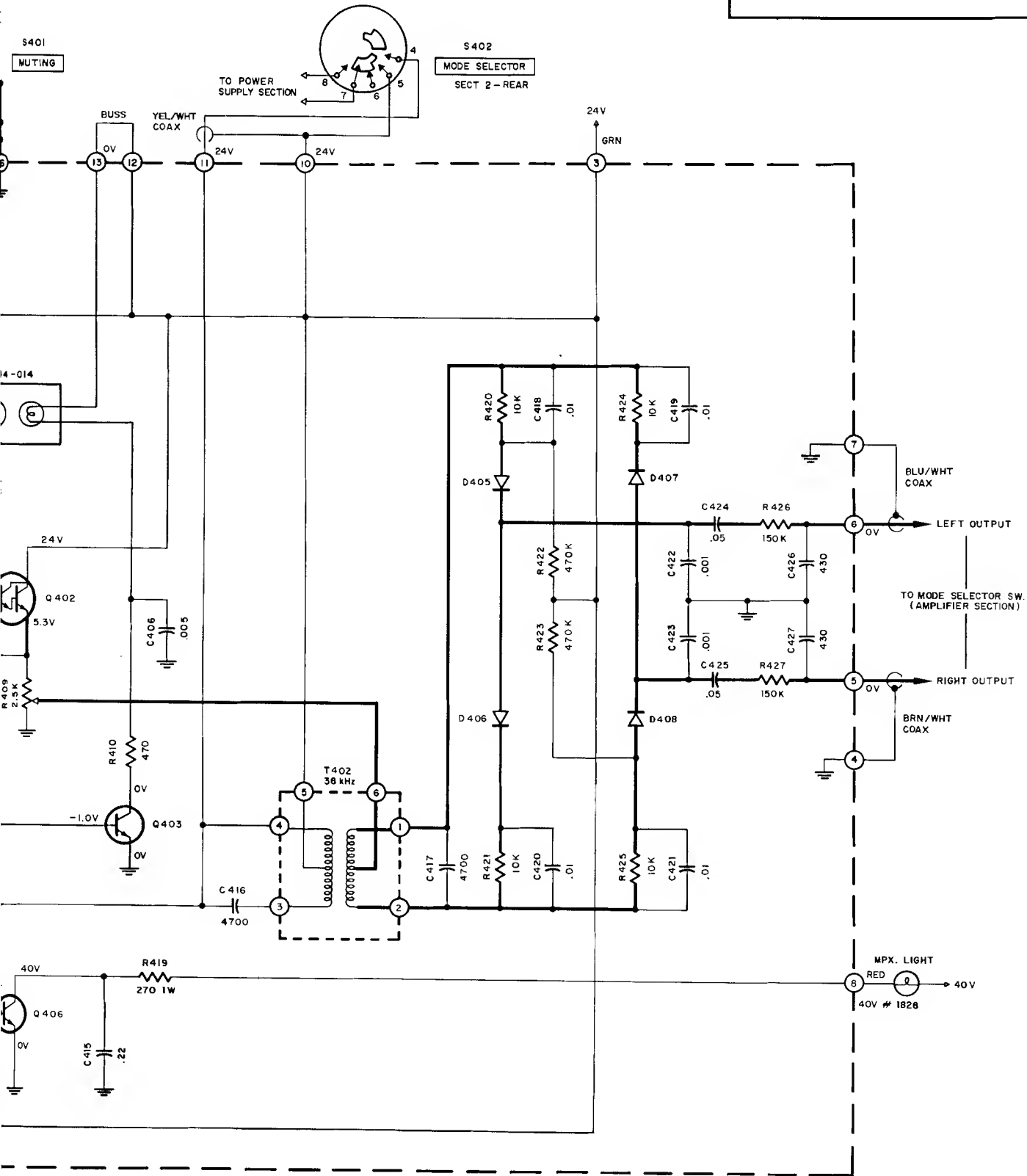

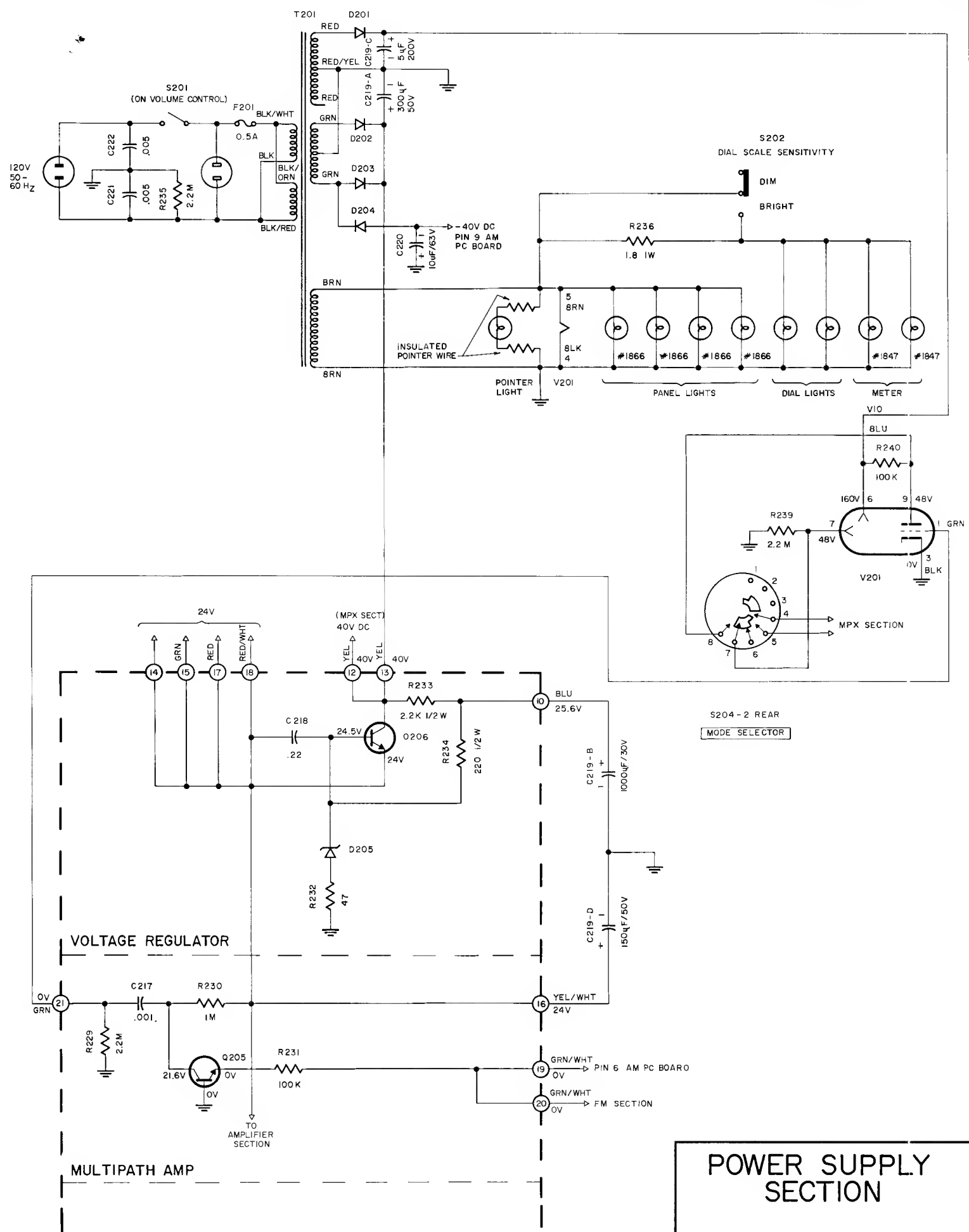

POWER SUPPLY SECTION

POWER SUPPLY & OUTPUT PC BOARD 044-298

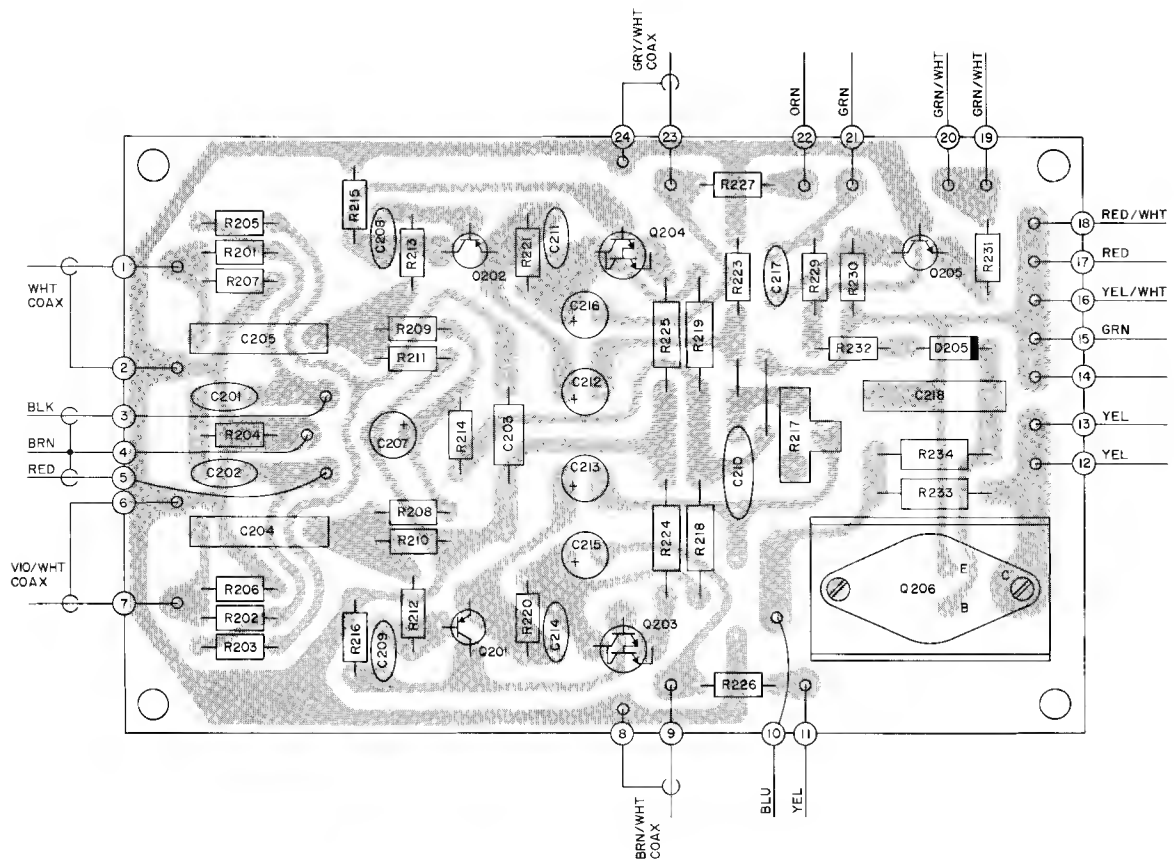

#1847

48V
3
BLK
GRN

.Y

TO RIGHT MPX OUTPUT
(MPX SECTION)

TO LEFT MPX OUTPUT
(MPX SECTION)

TO AM OUTPUT
(AM SECTION)

SECTION 1-FRONT

SECTION 1-REAR

S204
MODE SELECTOR

S203
STEREO FILTER

VIO/WHT
COAX

WHT COAX

TO POWER
SUPPLY SECTION

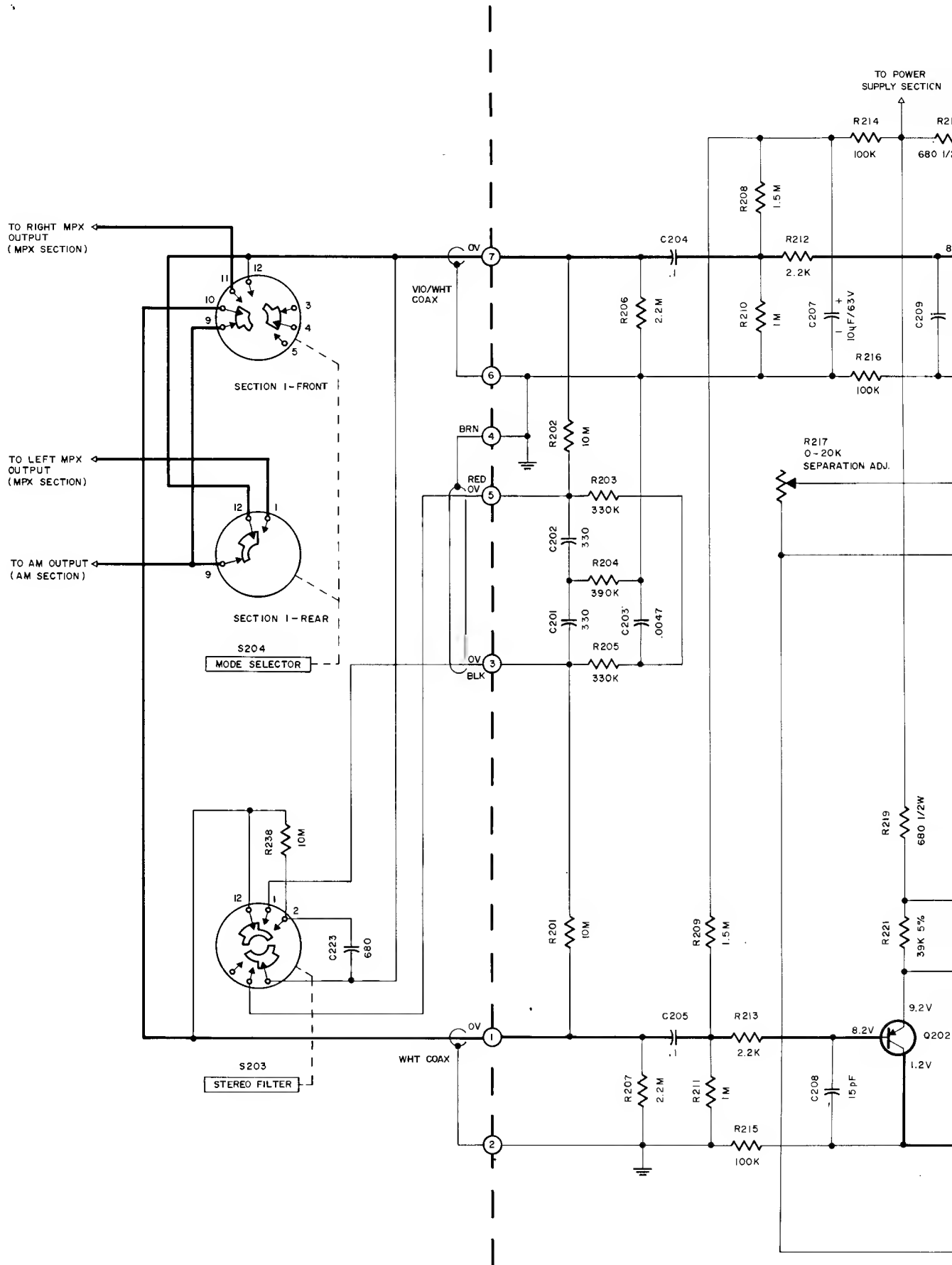

AMPLIFIER & VOLTAGE REGULATOR PC BOARD 044-

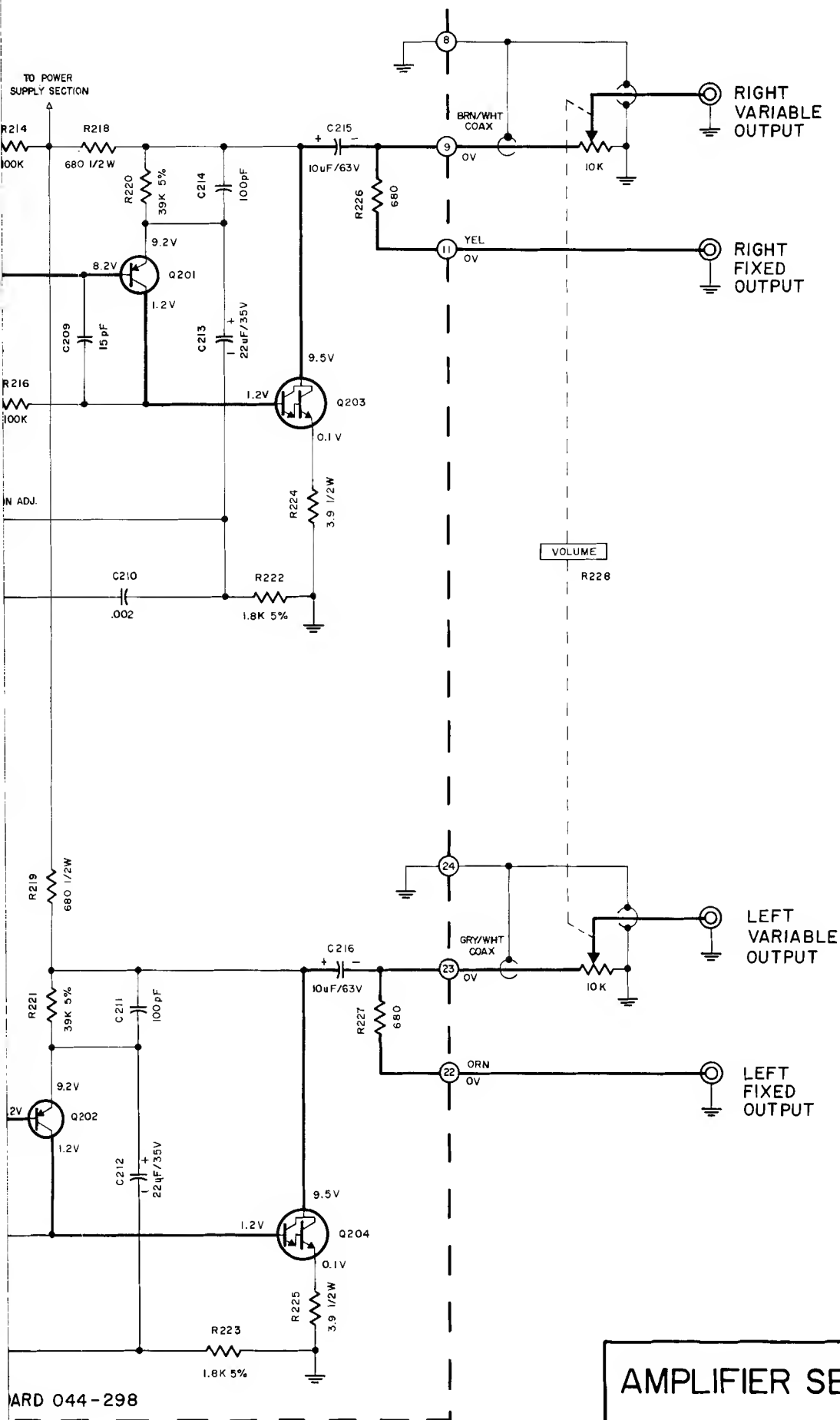

AMPLIFIER SECTION

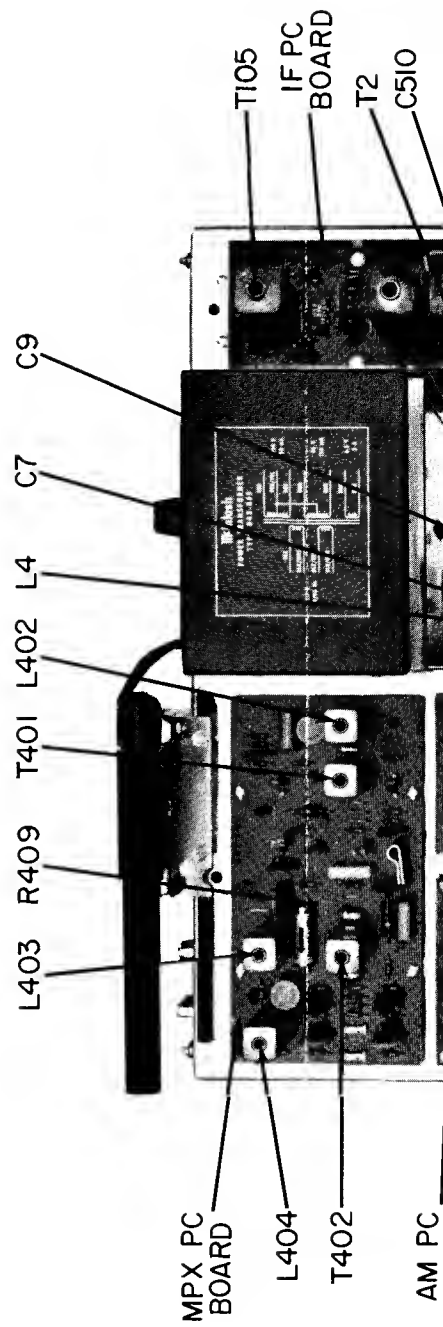
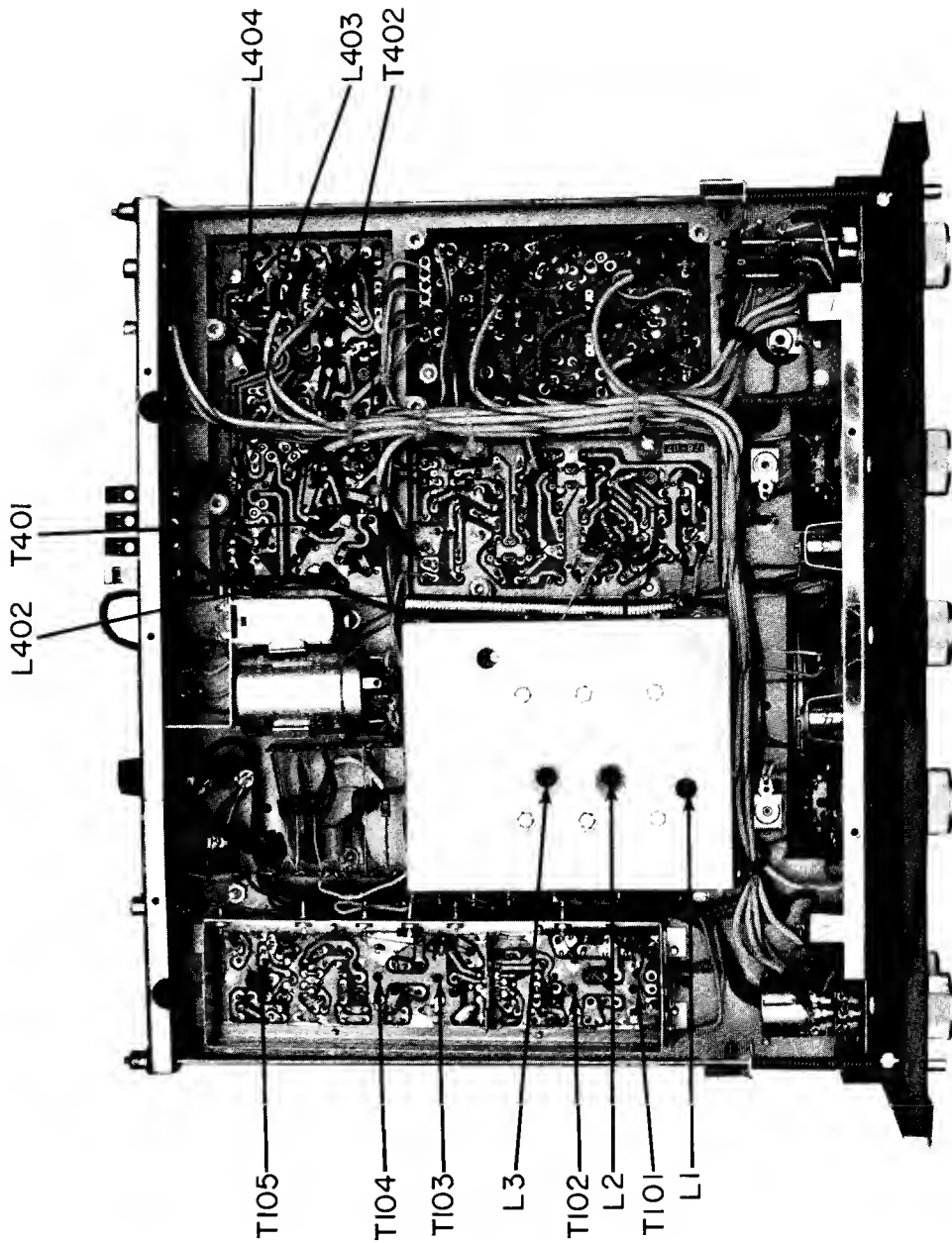

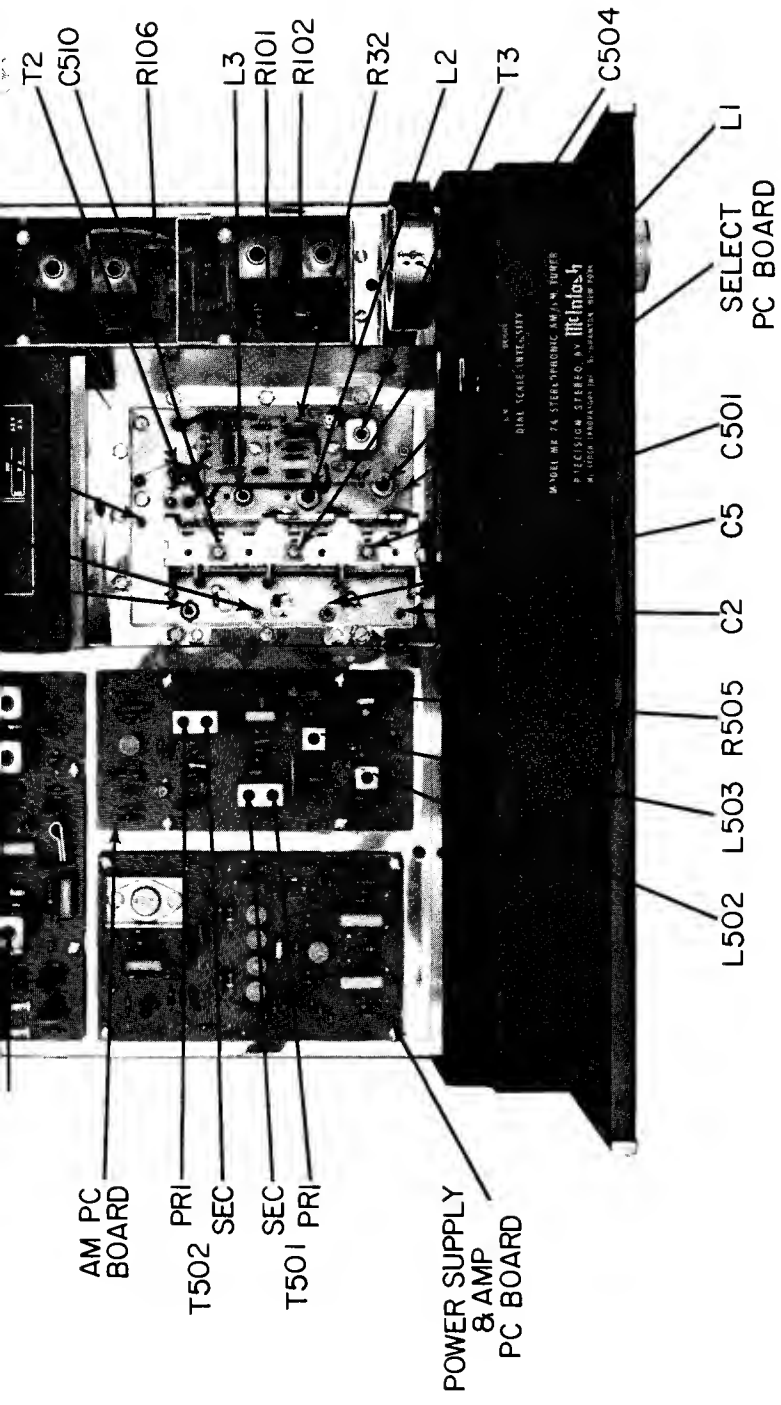

MR 74 ALIGNMENT INSTRUCTIONS

All McIntosh tuners are carefully aligned and tested at the factory using the finest available test equipment. All McIntosh tuners will meet their published specifications when shipped from the factory.

After extensive operation, or servicing, it may be desirable to realign the tuner circuits for best performance. The charts below give complete information on the circuit realignment procedure for the MR 74.

The test equipment listed (or its equivalent) is necessary to properly align an MR 74. The accuracy of the alignment will be directly related to the accuracy and calibration of the test equipment used.

If the necessary test equipment is not available, alignment should not be attempted. For additional information, contact Customer Service Department, McIntosh Laboratory, Inc., 2 Chambers Street, Binghamton, New York 13903 (telephone 607-723-3512).

Alignment should be done in the following order: AM-FM-MPX.

TEST EQUIPMENT REQUIRED

1. AM Signal Generator (Measurement 65B or equivalent).
2. FM Signal Generator (Measurement 188 or Sound Technology 1000A).
3. VTVM (RCA WV98C).
4. Multiplex Generator (Radiometer SMG1) or Sound Technology 1000A.
5. 10.7 MHz FM Sweep Generator (Kay 385 or equivalent). (Not needed if Measurement 275 IF converter is available.)
6. 10.7 MHz Generator (preferably crystal controlled).
7. Oscilloscope (Hewlett-Packard 120B or equivalent).
8. Harmonic Distortion Analyzer (Hewlett-Packard 333A or equivalent).
9. 10.7 MHz ± 75 kHz Sweep Marker Generator.

AM ALIGNMENT

	TUNER DIAL SETTING	SIGNAL GENERATOR			INDICATOR		ADJUST	TEST LIMITS	REMARKS
		FREQ.	COUPLING	MODULATION	TYPE	CONNECTED TO			
1	Point of no interference or signal	455kHz	Through external .01µF capacitor to pin 2 on AM circuit board	CW	Signal strength meter.	Normal	Pri. & Sec. cores of T501 & T502	As the tuner output increases, attenuate generator output to keep meter indication below 4. Selectivity switch remains in narrow position.	
2	600kHz	600kHz	Through a 200pF capacitor to ant. terminals.	Same	Same	Same	L503 (oscillator coil.)	Same as Step 1.	
3	1400kHz	1400kHz	Same	Same	Same	Same	C510 (oscillator trimmer)	Repeat Steps 2 & 3 until dial calibration is accurate.	
4	600kHz	600kHz	Same	Same	Same	Same	L501 (AM antenna rod) & L502 (AM-RF)	Same as Step 1 except adjust generator so that output signal is just above the noise level. Position antenna rod away from chassis and nearby objects.	
5	1400kHz	1400kHz	Same	Same	Same	Same	C501 (AM antenna trimmer) & C504 (AM-RF trimmer).	Repeat Steps 4 & 5 until output is as high as possible.	
6	600kHz	600kHz	Same	Same	Same	Same	T503 (AM external antenna transformer).	Same as Step 1.	
7	1400kHz	1400kHz	Same	Same	Same	Same	C522 (AM external antenna trimmer).	Repeat Steps 6 & 7 until output is as high as possible.	
8	1000kHz	1000kHz	Same	30% @ 400Hz	Distortion Analyzer	L or R fixed output jack.	R505 AM level.	With a distortion analyzer, the following measurements can be performed: 1. With a 10mV input signal adjust "AM level" control for .75 volts of audio output at fixed outputs. This will correspond to 2.5 volts audio output for a 100% modulated signal. 2. With a 1mV input signal, harmonic distortion, whistle filter attenuation at 10kHz modulating frequency and signal to noise ratio may be measured. 3. IHFM sensitivity of 75 microvolts for 20dB signal to noise ratio. (This measurement is only possible in the absence of man-made interference, as fluorescent lamps, etc.)	

to noise ratio. (This measurement is only possible in the absence of man-made interference, as fluorescent lamps, etc.)

FM ALIGNMENT

STEP	TUNER DIAL SETTING	SIGNAL GENERATOR			INDICATOR		ADJUST	TEST LIMITS	REMARKS
		FREQ.	COUPLING	MODULATION	TYPE	CONNECTED TO			
1	Point of no interference.	10.7MHz	Through external .01µF capacitor to Q4 gate.	FM ±200kHz sweep w/ 60Hz rate.	Oscilloscope	TP1	<p>Maximum height of 10.7MHz marker and best symmetry of 10.7MHz ±75kHz markers.</p> <p>Selectivity switch must be in the "select" position. All further test and alignment steps selectivity switch in "normal" position. Adjust R32 for equal height of markers in both positions of "select" switch.</p>	<p>Selectivity switch must be in the "normal" position. Turn muting off for alignment tests. Keep signal generator output low to prevent limiting.</p> <p>Selectivity switch must be in the "select" position. All further test and alignment steps selectivity switch in "normal" position. Adjust R32 for equal height of markers in both positions of "select" switch.</p>	
2	Same	Same	Same	Same	Same	Same	Same	<p>The linear phase filters as employed in the IF do not have a flat-topped response. See typical response curve - Fig. 2. Do not stagger tune.</p>	
3	Same	Same	Same	C.W.	VTVM	TP2	Zero DC at TP2.		
4	Same	Same	Same	Same	Same	Pin 6 of T105	Maximum possible negative voltage.	<p>If a distortion analyzer is available, omit this step. Adjust T105 (Pri.) after Step 6. At that time use a 1mV signal from an FM generator. Modulate 100% w/ 400Hz. Adjust primary of T105 for minimum distortion. Should be less than 0.3%.</p>	
5	105MHz	300Ω antenna terminals w/** matching network.	100% w/ 400Hz	VTVM connected to TPI and oscilloscope connected to L or R main output.	Same	Oscillator trimmer C9.	Maximum negative voltage at TPI.	<p>As TPI voltage increases reduce output of signal generator to keep TPI voltage as low as possible.</p>	
6	90MHz	Same	Same	Same	Same	Oscillator coil L4.	Same	Repeat steps 5 & 6 until dial calibration is accurate.	
7	105MHz	Same	Same	Same	Same	Mixer RF2, RF1 trimmers C7-5-2	Same	Same as step 5.	
8	90MHz	Same	Same	Same	Same	Mixer RF2, RF1 coils L3-2-1.	Same	Same as step 5. Then repeat steps 7 & 8 until TPI voltage is as high as possible for the least signal input at both alignment frequencies.	
9	Same	Same	Same	Same	VTVM connected to TPI and a harmonic distortion analyzer to L or R output.			<p>This step is an overall sensitivity check. Reduce input signal to the point where total noise and distortion reads 3% (-30dB). The input signal will then be the usable sensitivity and should be less than 2.5µV.</p>	

90MHz	90MHz	Same	Same	Same	Mixer RF2, RF1 coils L3-2-1.	Same	Same as step 5. Then repeat steps 7 & 8 until TPI voltage is as high as possible for the least signal input at both alignment frequencies.
Same	Same	Same	Same	VTVM connected to TPI and a harmonic distortion analyzer to L or R output.			This step is an overall sensitivity check. Reduce input signal to the point where total noise and distortion reads 3% (-30dB). The input signal will then be the usable sensitivity and should be less than 2.5µV.
Same	Same	Same	Same		R101, 102, 106		With generator output at 200µF, adjust R106 for sensitivity meter reading of 6. With generator output at 100kµV, adjust R101 for full scale of sensitivity meter. (Selectivity switch in "Normal".) Adjust R102 for full scale of sensitivity meter. (Selectivity switch in "Narrow".)

MULTIPLY DECODE ALIGNMENT

	TUNER DIAL SETTING	SIGNAL GENERATOR			INDICATOR		ADJUST	TEST LIMITS	REMARKS
		FREQ.	COUPLING	MODULATION	TYPE	CONNECTED TO			
1	100MHz	100MHz	300Ω antenna terminals w/ approx. 1000 microvolts signal w/* matching network.	75kHz Deviation @ 67kHz	AC-VTVM	L or R output jack.	L403 and L404 (SCA adj.)	Minimum output L or R output jack.	Adjust for minimum output with 67kHz modulation.
2	100MHz	100MHz	Same	19kHz stereo pilot.	AC-VTVM or oscilloscope w/very low cap. probe.	T401, Pin 2 or 3.	L402 (19kHz phase adj.) & T401 (19 kHz doubler)	Adjust for maximum AC voltage.	Decrease pilot level, if necessary, so that 19kHz circuits do not limit or saturate.
3	Same	Same	Same	Same	Same	T402, Pin 1 or 2.	T402 (Pri) & bottom (Sec) tuning slugs	Adj. for maximum AC voltage.	Decrease pilot level so that 19kHz and 38kHz circuits do not limit. Mode switch must be in stereo position.
4	Same	Same	Same	1kHz (100% modulation) L or R only, pilot level normal and on.	Same	L or R output jack.	T402, Bottom (Sec.) tuning slug. Also adj. R217.	35dB separation or more.	First, set R217 to MAX resistance. Modulate left channel and measure right channel output. Adjust T402 bottom - tuning slug (Sec.) for minimum right channel output (maximum separation). Then adjust R217 for maximum separation. Repeat the adjustment of T402 bottom and R217 until maximum separation is obtained. Then, reverse channels and measure left channel separation. For this adjustment and measurement, no test lead should be connected to TP#2.
5	100MHz	100MHz	Same	1kHz (100% modulation) L or R only, pilot on.	AC-VTVM	L or R fixed output jack.		Less than 25mV of residual.	Adjust "IFM Level" control (R409) for 2.5 volts of audio output at fixed output jacks. Then, turn off the modulation and measure the residual of the 19kHz and 38kHz frequencies.

3	Same	Same	Same	Same	T402, Pin 1 or 2.	T402 (Pri) & bottom (Sec) tuning slugs	Adj. for maximum AC voltage.	Decrease pilot level so that 19kHz and 38kHz circuits do not limit. Mode switch must be in stereo position.
4	Same	Same	1kHz (100% modulation) L or R only, pilot level normal and on.	Same	L or R output jack.	T402, Bottom (Sec.) tuning slug. Also adj. R217.	35dB separation or more.	First, set R217 to MAX resistance. Modulate left channel and measure right channel output. Adjust T402 bottom - tuning slug (Sec.) for minimum right channel output (maximum separation). Then adjust R217 for maximum separation. Repeat the adjustment of T402 bottom and R217 until maximum separation is obtained. Then, reverse channels and measure left channel separation. For this adjustment and measurement, no test lead should be connected to TP#2.
5	100MHz	Same	1kHz (100% modulation) L or R only, pilot on.	AC-VTVM	L or R fixed output jack.		Less than 25mV of residual.	Adjust "FM Level" control (R409) for 2.5 volts of audio output at fixed output jacks. Then, turn off the modulation and measure the residual of the 19kHz and 38kHz frequencies.

Note 1: If signal generator has other than 50 ohm internal impedance, use a resistor of 150 ohms less internal generator impedance.

FIG. 1 ANTENNA MATCHING NETWORK

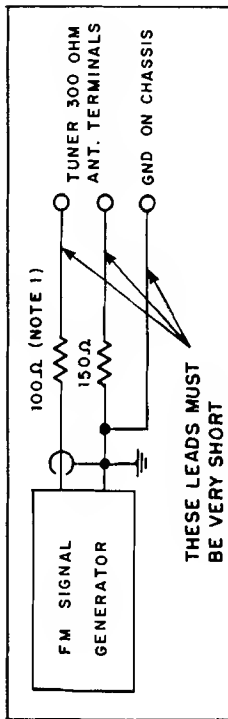
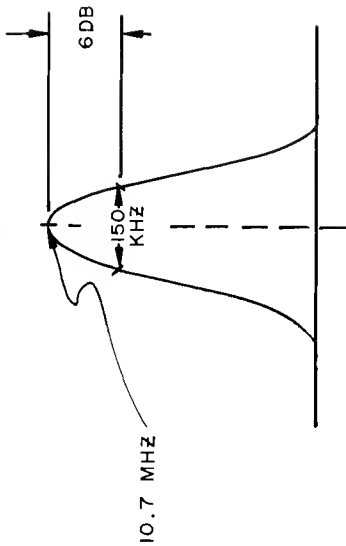

FIG. 2 TYPICAL IF RESPONSE CURVE



REPLACEMENT PARTS

All parts not listed are common items obtainable from radio parts jobbers.

Replacement parts may be obtained when ordered by PART NUMBER from:

McIntosh Laboratory, Inc.
Customer Service Department
2 Chambers Street
Binghamton, New York 13903
(telephone 607-723-3512)

CAPACITORS

Symbol Number	Description	Part Number
C109	Ta. Elect. 22 μ F 20V	066-148
C201,202	Polystyrene 2700pF	064-093
C203	Polystyrene 4700pF	064-091
C204,205	Mylar .1 μ F	064-067
C207	Elect. 10 μ F 63V	066-178
C212,213	Elect. 22 μ F 35V	066-179
C215,216	Elect. 10 μ F 63V	066-178
C218	Mylar .22 μ F 250V	064-068
C219	Elect. 5/300/150/100 μ F 200/50/50/30V	066-180
C220	Elect. 10 μ F 63V	066-178
C401	Mylar .22 μ F 250V	064-068
C405	Elect. 100 μ F 25V	066-161
C408	Elect. 100 μ F 25V	066-161
C410	Polystyrene 2700pF 63V	064-093
C411	Ta. Elect. 1 μ F 35V	066-147
C413	Mylar .1 μ F 250V	064-067
C415	Mylar .22 μ F 250V	064-068
C416,417	Polystyrene 4700pF	064-091
C502	Polystyrene 4700pF	064-091
C503	Ta. Elect. .47 μ F 35V	066-167
C507	Ta. Elect. 3.3 μ F 35V	066-170
C515	Polyester .01 μ F	064-101
C518	Polystyrene 2700pF 63V	064-093
C520	Elect. 10 μ F 63V	066-178
C527	Elect. 100 μ F 25V	066-161

DIODES

D1	Ge. signal diode	070-003
D2,3	Si. diode	070-022
D101,102	Si. diode	070-022
D103,104	Ge. signal diode	070-003
D105,106	Ge. signal diode	070-003

D107,108	Si. diode	070-022
D201,202	Si. diode	070-031
D203,204	Si. diode	070-031
D205	Zener diode 24V	070-049
D401	Si. diode	070-003
D402,403	Si. diode	070-022
D404	Si. diode	070-022
D405,406	Ge. signal diode	070-003
D407,408	Ge. signal diode	070-003
D409	Ge. signal diode	070-003
D501	Si. diode	070-022
D502,503	Ge. signal diode	070-003

CHOKES & COILS

L1	1st RF coil	122-115
L2	2nd RF coil	122-114
L3	Mixer coil	122-113
L4	Oscillator coil	122-112
L101,102	Choke 75 μ H	122-013
L401	Choke 1MH	122-092
L402	Filter coil (19kHz)	122-094
L403,404	Filter coil (SCA)	122-093
L501	AM antenna	122-110
L502	AM RF coil	122-086
L503	AM oscillator coil	122-085
L504	Choke 1.2 μ H	122-011

TRANSISTORS

Q1,2	Si. M.O.S. F.E.T.	132-088
Q3	Si. NPN transistor	132-015
Q4	Si. Junction F.E.T.	132-084
Q5	Si. Junction F.E.T.	132-068
Q6	Si. M.O.S. F.E.T.	132-086
Q201,202	Si. NPN transistor	132-056
Q203,204	Si. NPN transistor	132-090
Q205	Si. NPN transistor	132-054
Q206	Si. NPN transistor	132-065
Q401	Si. NPN transistor	132-092
Q402	Si. NPN transistor	132-090
Q403,404	Si. NPN transistor	132-092
Q405	Si. NPN transistor	132-092
Q406	Si. NPN transistor	132-042
Q501,502	Si. NPN transistor	132-082
Q503	Si. NPN transistor	132-082
Q504	Si. NPN transistor	132-090

F201

R228

R236

R237

S203

S204

S401

S502

T1

T2

T3

T101

T102

T103

T104

T105

T201

T401

T402

T501

T502

M40

M50

IC1

FN1

XF5

diode	070-022
diode	070-031
diode	070-031
er diode 24V	070-049
diode	070-003
diode	070-022
diode	070-022
signal diode	070-003
signal diode	070-003
signal diode	070-003
diode	070-022
signal diode	070-003
HOOKES & COILS	
RF coil	122-115
RF coil	122-114
er coil	122-113
illator coil	122-112
ke 75 μ H	122-013
ke 1MH	122-092
ter coil (19kHz)	122-094
ter coil (SCA)	122-093
antenna	122-110
RF coil	122-086
oscillator coil	122-085
ke 1.2 μ H	122-011
TRANSISTORS	
M.O.S. F.E.T.	132-088
NPN transistor	132-015
Junction F.E.T.	132-084
Junction F.E.T.	132-068
M.O.S. F.E.T.	132-086
NPN transistor	132-056
NPN transistor	132-090
NPN transistor	132-054
NPN transistor	132-065
NPN transistor	132-092
NPN transistor	132-090
NPN transistor	132-092
NPN transistor	132-092
NPN transistor	132-042
NPN transistor	132-082
NPN transistor	132-082
NPN transistor	132-090

FUSES			
F201	Fuse .5A slo-blo		089-020
POTENTIOMETERS			
R228	Volume control		134-217
RESISTORS			
R236	Wirewound 1.8 Ω	1W	139-077
R237	Wirewound 2 Ω	2W	139-005
SWITCHES			
S203	Stereo filter switch		146-137
S204	Mode selector switch		146-135
S401	Muting switch		146-138
S502	Selectivity switch		146-154
TRANSFORMERS			
T1	Balun		043-226
T2	FM IF transformer		162-059
T3	FM IF transformer		162-042
T101	FM IF filter input		162-053
T102	FM IF filter output		162-052
T103	FM IF filter input		162-053
T104	FM IF filter output		162-052
T105	FM discriminator		162-036
T201	Power transformer		043-865
T401	FM RF transformer (19kHz)		162-055
T402	FM RF transformer (38kHz)		162-054
T501,502	AM IF transformer		162-050
T503	Matching transformer		162-061
MODULES			
	LDR network		144-013
METERS			
M401	Signal strength meter		124-005
M501	Tuning meter		124-006
INTEGRATED CIRCUIT			
IC101,102	Integrated circuit		133-002
FILTERS			
FN1	FM filter		180-009
XF501	AM filter		180-010
LAMPS			
	#1847 (Meter)		058-008
	#1866 (Front Panel)		058-014

#1828 (MPX)	
Festoon lamp	
FRONT PANEL	
Front panel	
Front panel end	
Volume knob	
Tuning knob	
Mode selector	
Stereo filter	
Selectivity knob	
FM muting knob	
MOUNTING	
Shelf bracket	
Shelf bracket	
Mounting template	
Hardware packag	
MISCELLANEOUS	
Plastic feet	
Tuning shaft	
Shipping cartons	
Push terminal	
Owners manual	
Dial cord	
Dial pointer	
Shorting plug	
AC line cord	
FM dipole antenna	
Fuseholder	
Dial glass	
15C0214S7	

#1828 (MPX)	058-027
Festoon lamp	058-032
FRONT PANEL & TRIM	
Front panel	044-303
Front panel end caps	018-120
Volume knob	044-372
Tuning knob	043-272
Mode selector knob	044-372
Stereo filter knob	043-428
Selectivity knob	043-428
FM muting knob	043-428
MOUNTING SYSTEM	
Shelf bracket (right)	043-622
Shelf bracket (left)	043-623
Mounting template #100	038-179
Hardware package	043-446
MISCELLANEOUS ITEMS	
Plastic feet	017-041
Tuning shaft	021-067
Shipping carton	
Push terminal (antenna)	074-032
Owners manual	038-552
Dial cord	044-226
Dial pointer	043-876
Shorting plug	127-021
AC line cord	170-021
FM dipole antenna	170-033
Fuseholder	178-001
Dial glass	