

McIntosh

MQ 102

ENVIRONMENTAL EQUALIZER



SERVICE INFORMATION

STARTING WITH SERIAL NO. 1W001

ELECTRICAL SPECIFICATIONS

FREQUENCY RESPONSE

± 0.5 dB from 20Hz to 20,000Hz (with equalization switches in position 1).

DISTORTION

Less than 0.1% at rated output level, 20Hz to 20,000Hz.

HUM AND NOISE

Less than 85dB below rated output (140 μ V).

INPUT SENSITIVITY AND IMPEDANCE

Main and tape input 2.5 volts at 75k Ω for rated output at 1000Hz.

INPUT ATTENUATOR

Switched 0dB, -6dB, or -12dB.

OUTPUT

Main: 2.5 volts into 47k Ω or greater load, 20Hz to 20,000Hz.

Tape: 2.5 volts with rated input.

LOW FREQUENCY EQUALIZATION

0 to +17dB at 20Hz in steps (0, +6, +10, +14, +17dB in positions 1, 2, 3, 4, 5 respectively.)

POWER REQUIREMENT

120 volts, 50/60Hz, 4 watts

EQUALIZER PC BOARD 044-213

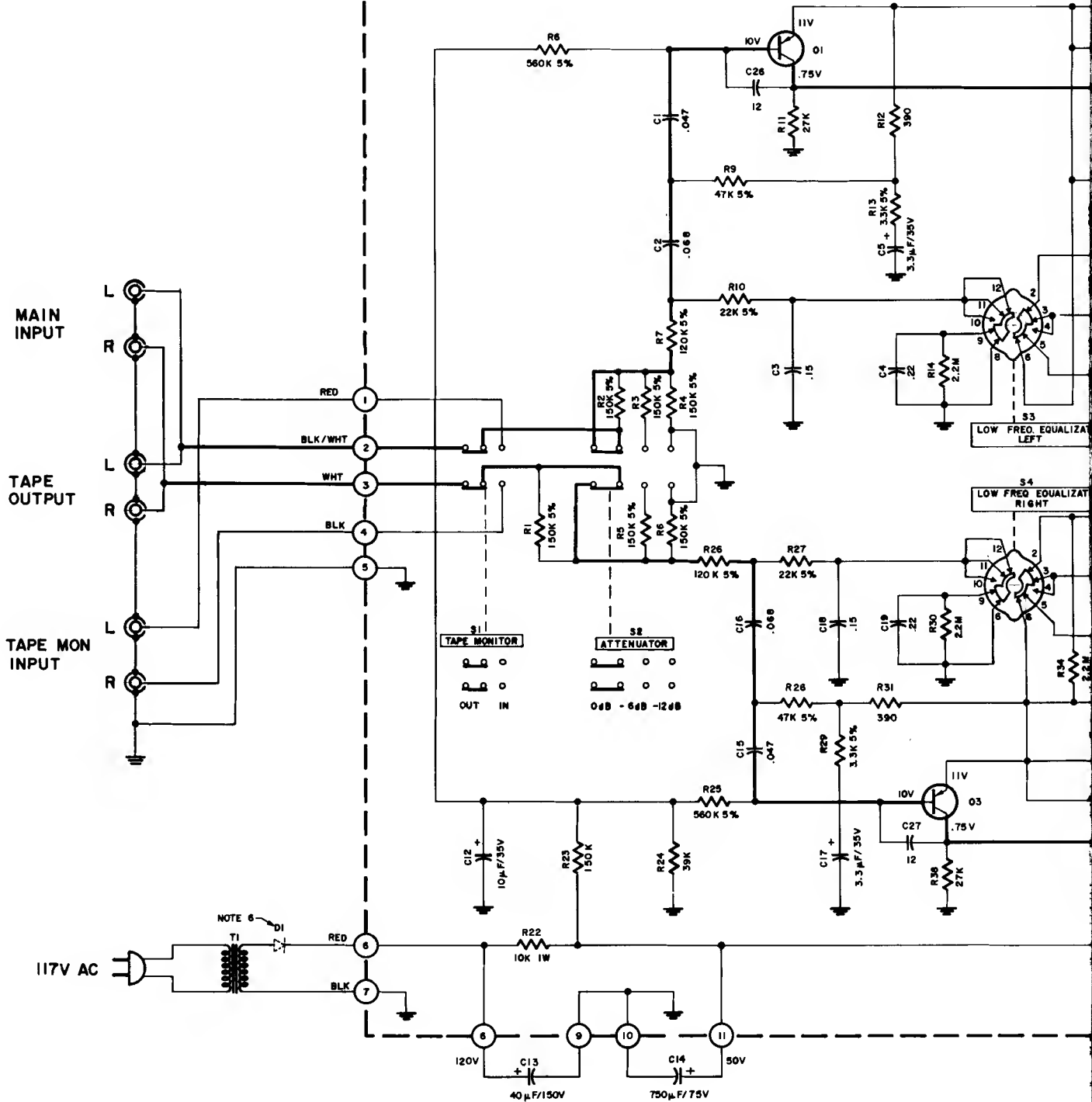

213

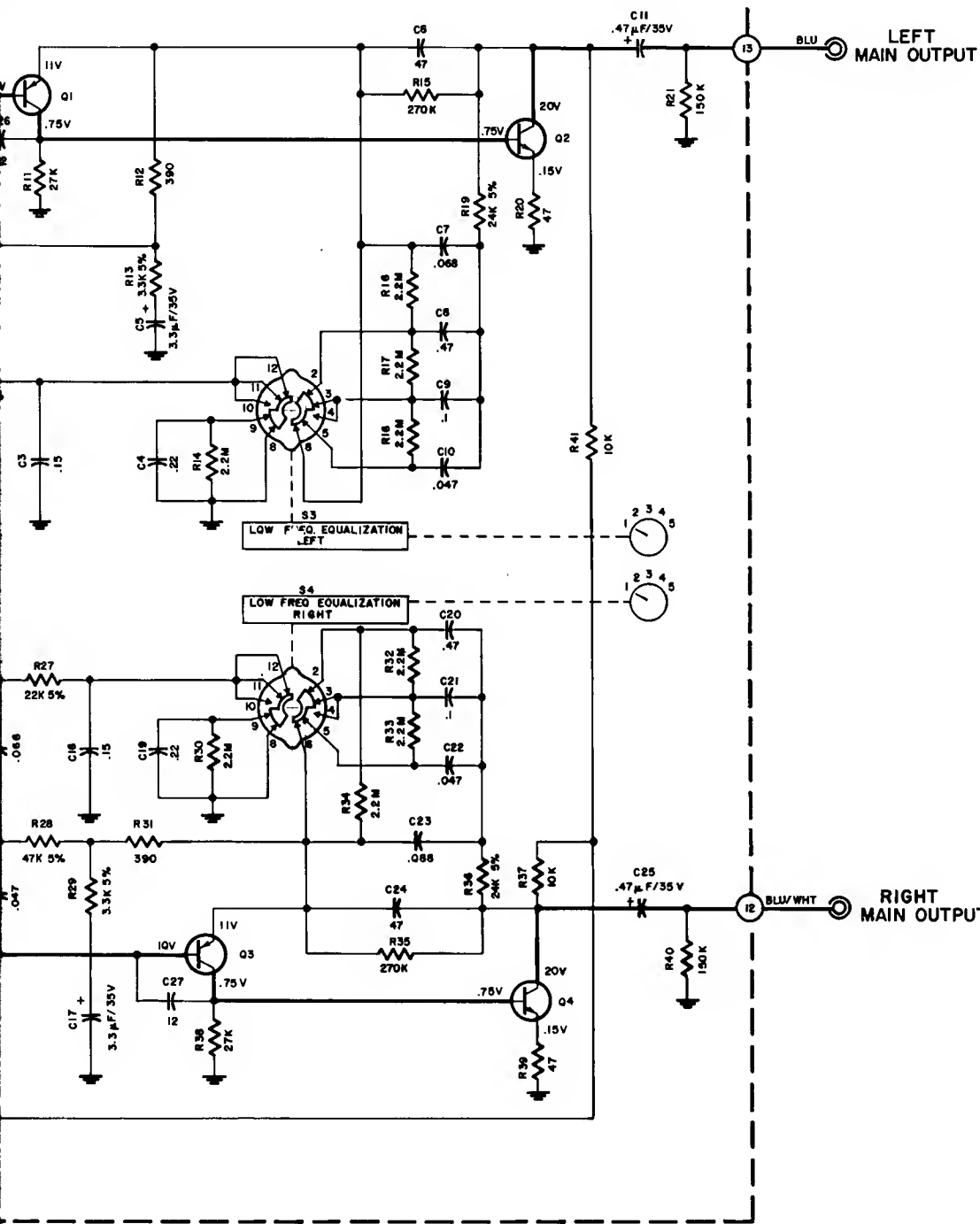

1. Unless ohms, smaller values
2. Printed schematics around the PD
3. The ha signal
4. The te erence
5. All vo under
 - a. Us
 - b. Al
 - c. No
 - d. AO
6. In un DI (Mo

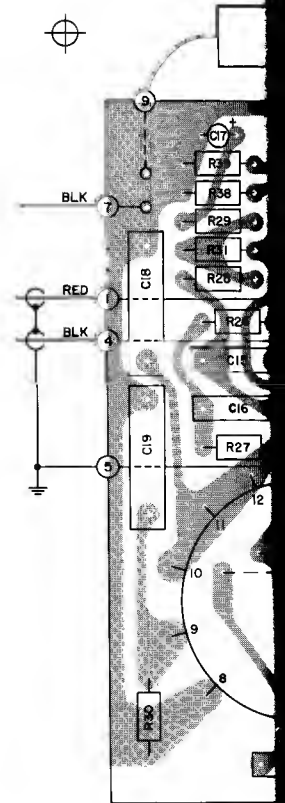

SCHEMATIC NOTES

1. Unless otherwise specified: Resistance values are in ohms, 1/4 watt, and 10% tolerance; capacitance values smaller than 1 are in microfarads (μF); capacitance values greater than 1 are in picofarads (pF).
2. Printed circuit board components are outlined on the schematics by dotted lines. The circles numbers around the dotted lines correspond to the numbers on the PC Board layouts.
3. The heavy lines on the schematics denote the primary signal path.
4. The terminal numbering of rotary switches is for reference only.
5. All voltages indicated on the schematics are measured under the following conditions:
 - a. Use of an 11 megohm input impedance VTVM.
 - b. All voltages $\pm 10\%$ with respect to chassis ground.
 - c. No signal at input or terminals.
 - d. AC input at 117 volts, 50/60 Hz.
6. In units using power transformer 159-095, Si. rectifier DI (McIntosh part number 070-031) is used.

LEFT
MAIN OUTPUT

RIGHT
MAIN OUTPUT

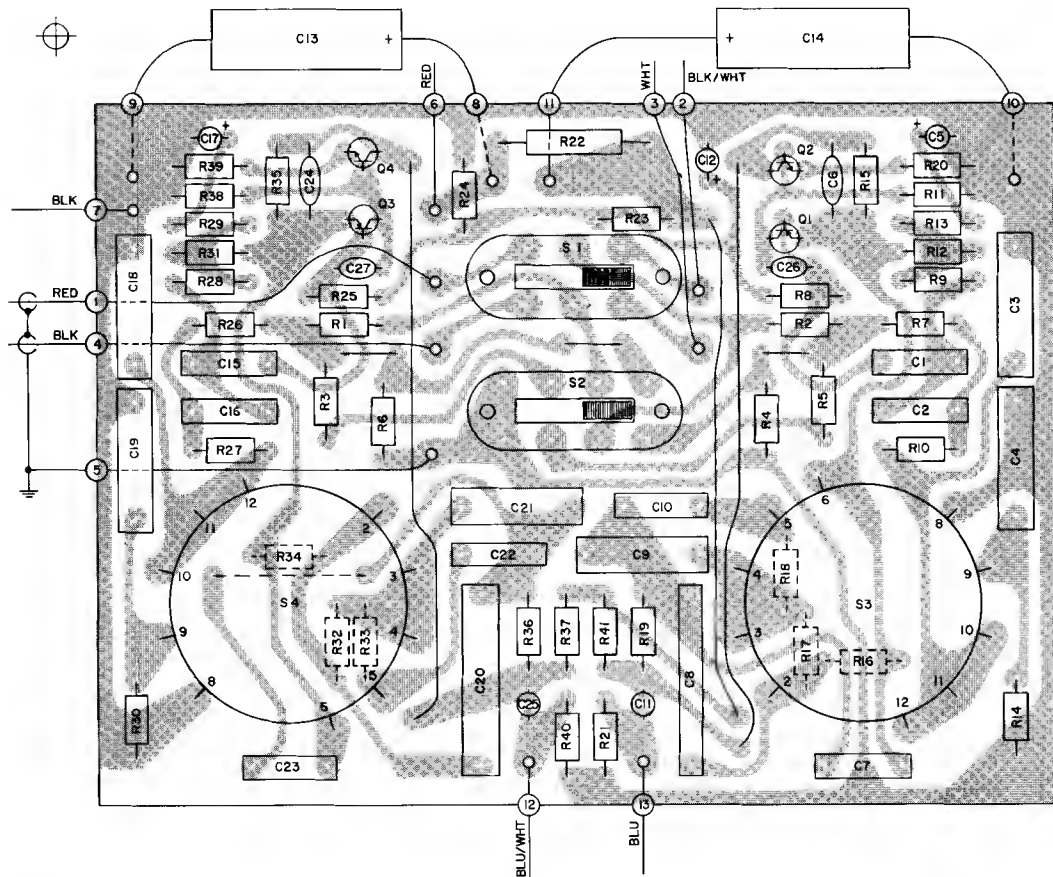

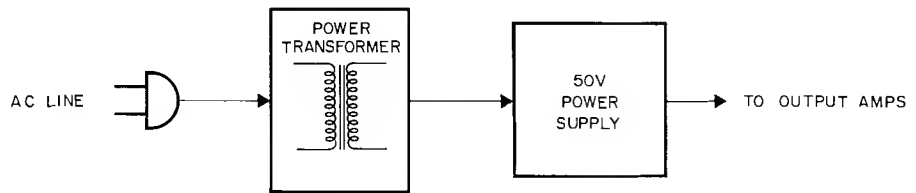
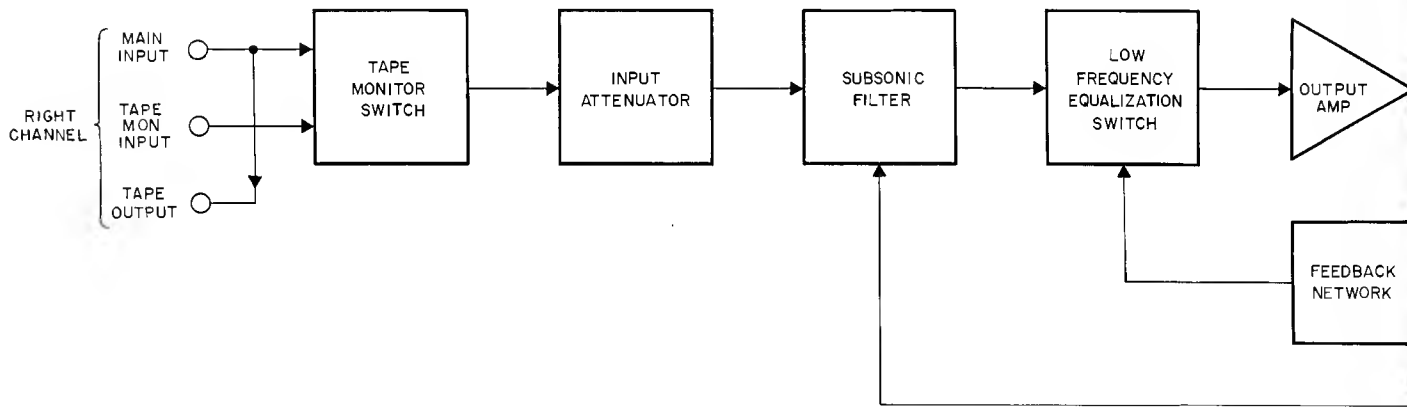
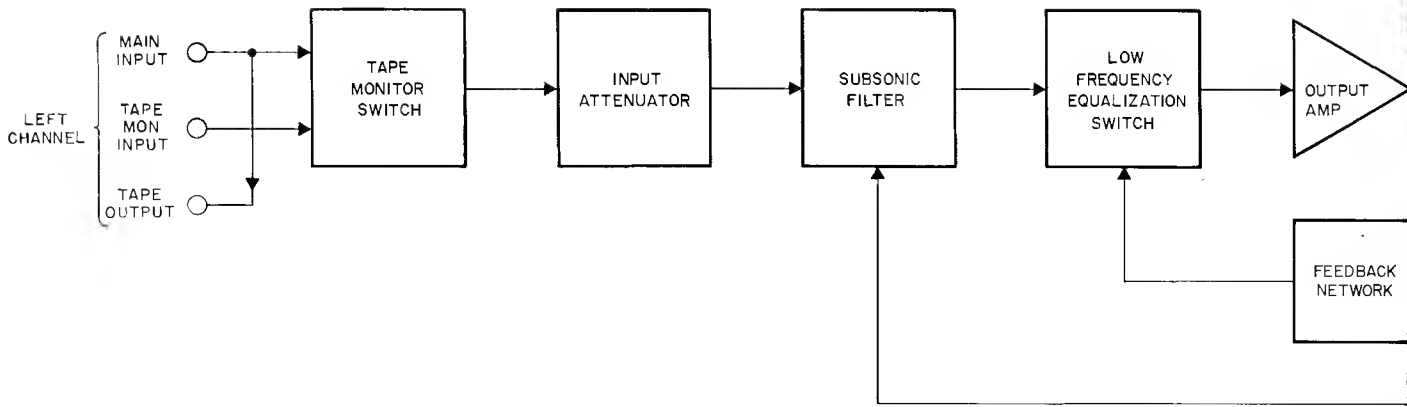

MQ 102 BLOCK DIAGRAM

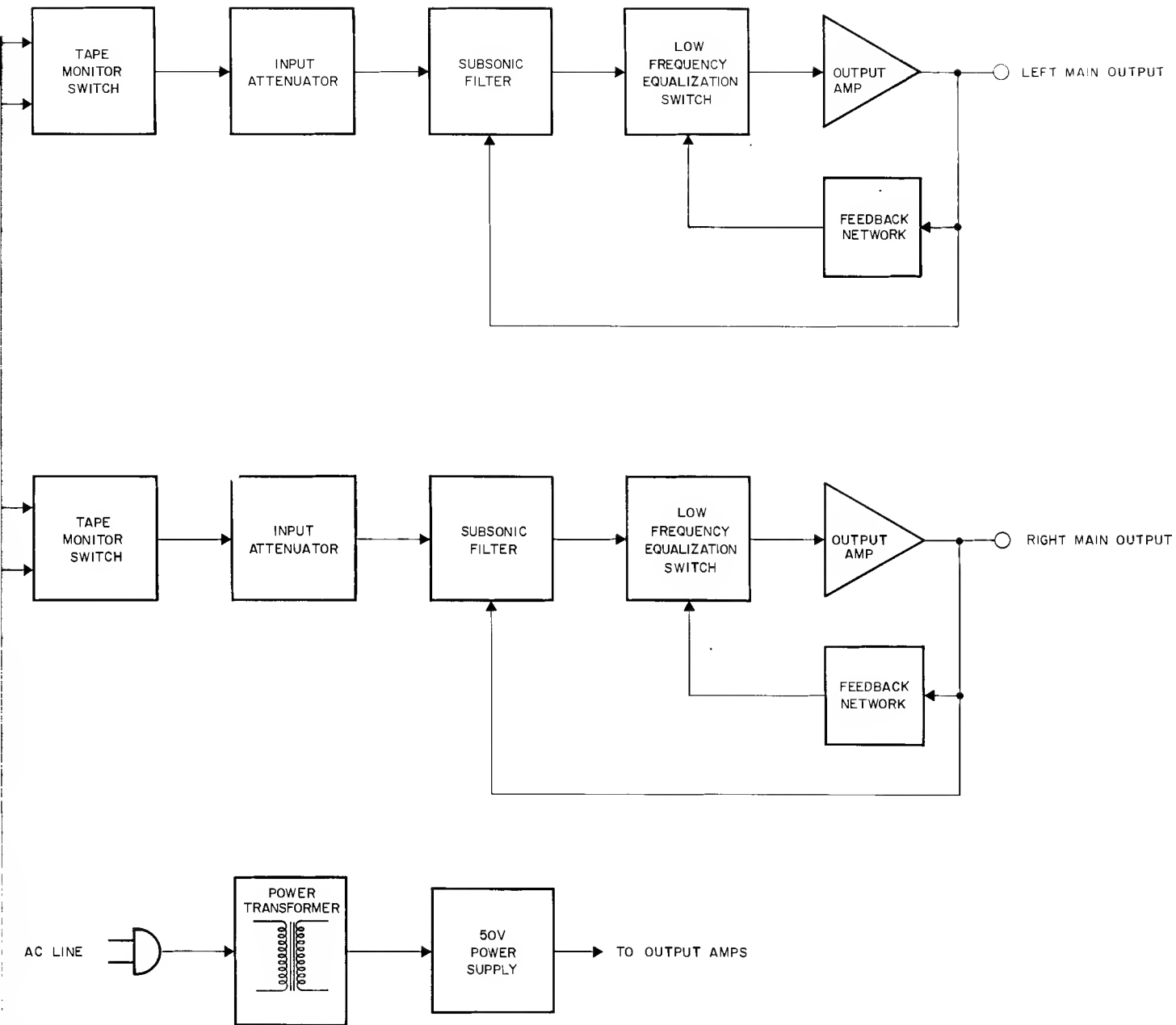

MQ 102 BLOCK DIAGRAM

REPLACEMENT PARTS

All parts not listed are common items obtainable from radio parts jobbers.

Replacement parts may be obtained when ordered by PART NUMBER from:

McIntosh Laboratory, Inc.
Customer Service Department
2 Chambers Street
Binghamton, New York 13903
(telephone 607-723-3512)

CAPACITORS

C1	Mylar	.047 μ F	250V	064-085
C2	Mylar	.068 μ F	250V	064-095
C3	Mylar	.15 μ F	250V	064-100
C4	Mylar	.22 μ F		064-096
C5	Tant. Elect.	3.3 μ F	35V	066-170
C7	Mylar	.068 μ F	250V	064-095
C8	Mylar	.47 μ F	250V	064-069
C9	Mylar	.1 μ F	250V	064-067
C10	Mylar	.047 μ F	250V	064-085
C11	Tant. Elect.	.47 μ F	35V	066-167
C12	Tant. Elect.	10 μ F	35V	066-239
C13	Elect.	40 μ F	150V	066-169
C14	Elect.	750 μ F	75V	066-168
C15	Mylar	.047 μ F	250V	064-085
C16	Mylar	.068 μ F	250V	064-095
C17	Elect.	3.3 μ F	35V	066-170
C18	Mylar	.15 μ F	250V	064-100
C19	Mylar	.22 μ F		064-096
C20	Mylar	.47 μ F	250V	064-069
C21	Mylar	.1 μ F	250V	064-067
C22	Mylar	.047 μ F	250V	064-085
C23	Mylar	.068 μ F	250V	064-095
C25	Tant. Elect.	.47 μ F	35V	066-167

DIODES

D1	Si Rectifier	070-031
----	--------------	---------

TRANSISTORS

Q1	Si. PNP transistor	132-096
Q2	Si. NPN transistor	132-094
Q3	Si. PNP transistor	132-096
Q4	Si. NPN transistor	132-094

SWITCHES

S1	Tape monitor	148-030
S2	Attenuator	148-029
S3,4	Equalization switch	146-150

TRANSFORMERS

T1	Power transformer	159-095
----	-------------------	---------

MISCELLANEOUS ITEMS

	Owners manual	038-834
	Shipping carton	033-133
	Equalization knob	090-011
	AC power cord	170-021
	Audio cable	170-015