

McIntosh

ML 2M LOUDSPEAKER SYSTEM

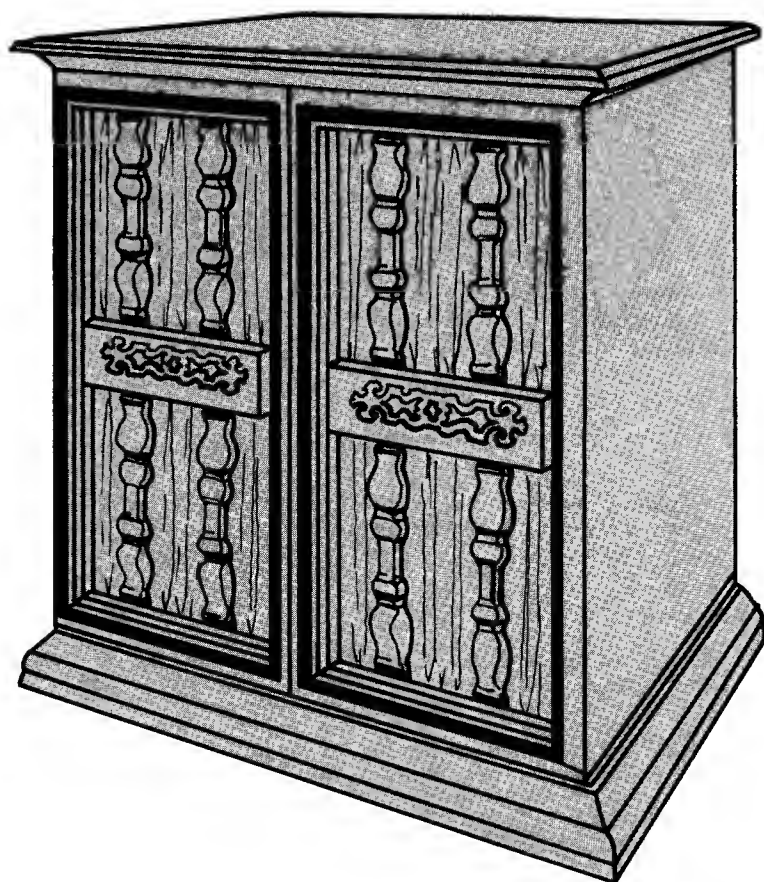

SERVICE INFORMATION

SERIAL NO. L1D001 AND ABOVE
BD1509 TO BD1586

SPECIFICATIONS

SPEAKER SIZE

Woofers two 12" dia. frame size (10" dia. radiators)
Low mid-range 8" dia. frame size (5" dia. radiator)
Mid mid-range 1-1/2" dia. dome radiator
High mid-range 1-1/2" dia. dome radiator
Tweeter 1-5/8" dia. coaxial super radiator

CROSSOVER FREQUENCIES

250Hz, 1.5kHz, 3kHz, & 7kHz

IMPEDANCE

8 Ω Nominal

POWER HANDLING: Sine Wave steady state

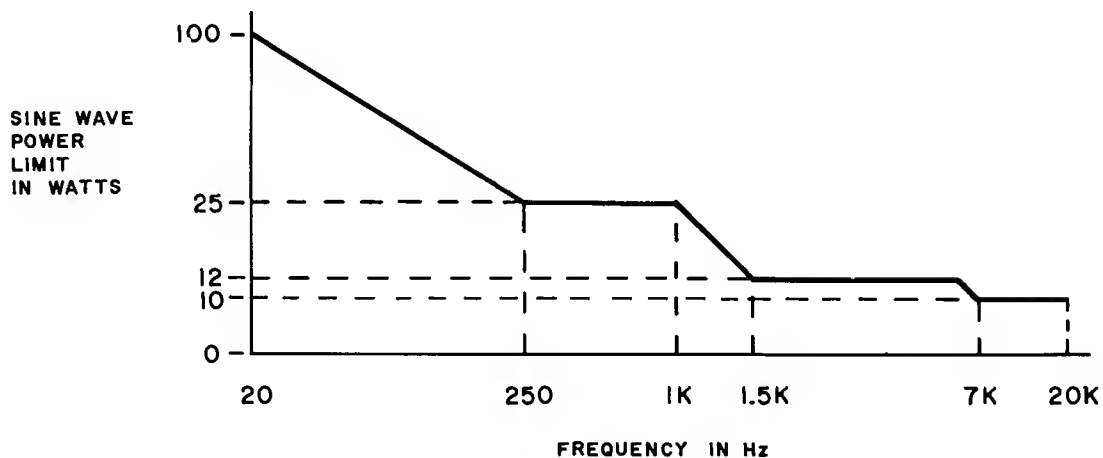

Avoid operating the speaker system with sustained sine wave signals at power levels greater than the indicated limits. Permanent damage may result.

POWER HANDLING: Program Material

High energy peaks normal to orchestral music are easily and faithfully reproduced by the speaker system. These peaks are of relatively short duration and do not produce the heating effect caused by sustained tone operation. The ML-4 speaker system will handle up to 300 watts of orchestral music program material. Care must be taken, however, to use a power amplifier that has an adequate power rating. If a low power amplifier is used, the loudest passages may be "clipped" by the amplifier. This clipping will cause the speaker to sound distorted. The large harmonic content of a badly "clipped" signal can cause excessive heating and resulting damage to the high frequency speaker elements and crossover network.

OUTPUT LEVEL

In a reverberant room the system will nominally produce an 89dB sound pressure level when driven at a one watt level referred to 8 Ω .

SPEAKER LOCATION

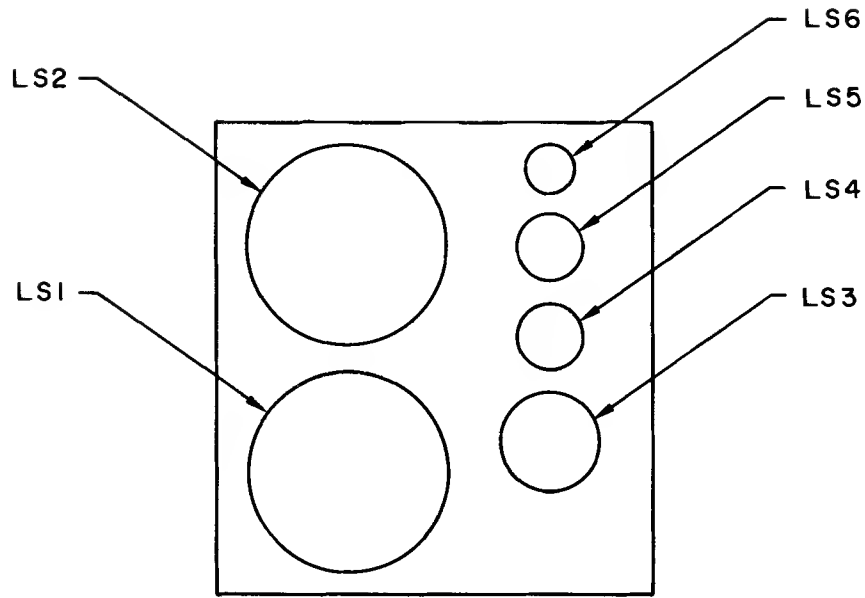

REMOVE REAR PANEL TO SERVICE CROSSOVER NETWORK

SCHEMATIC NOTES

1. In early units LS6 is 036-005 16 Ω impedance. LS6 can be replaced with 036-012 8 Ω impedance. Acoustic output will be the same.

CROSSOVER NETWORK

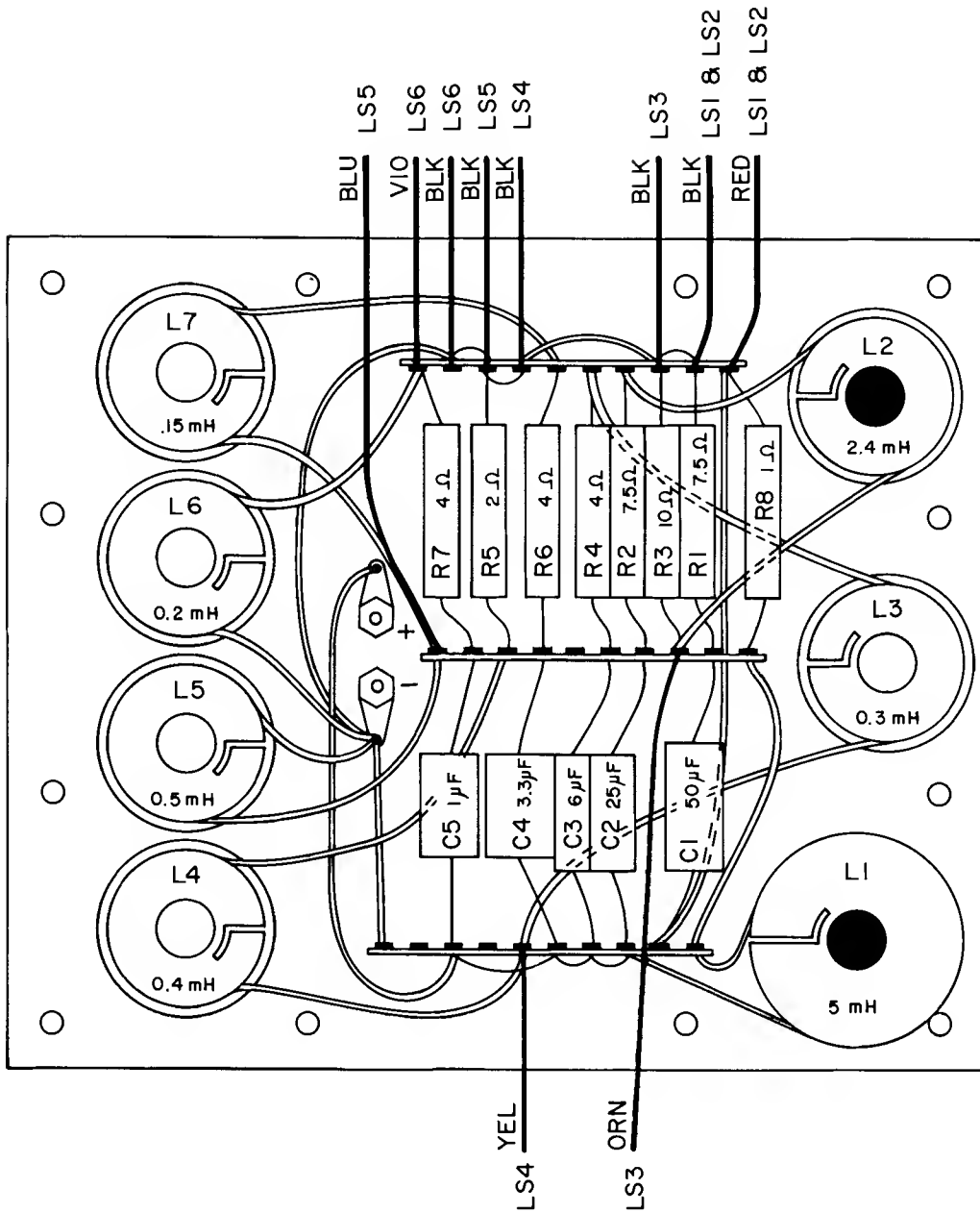

ASSEMBLY 044-222

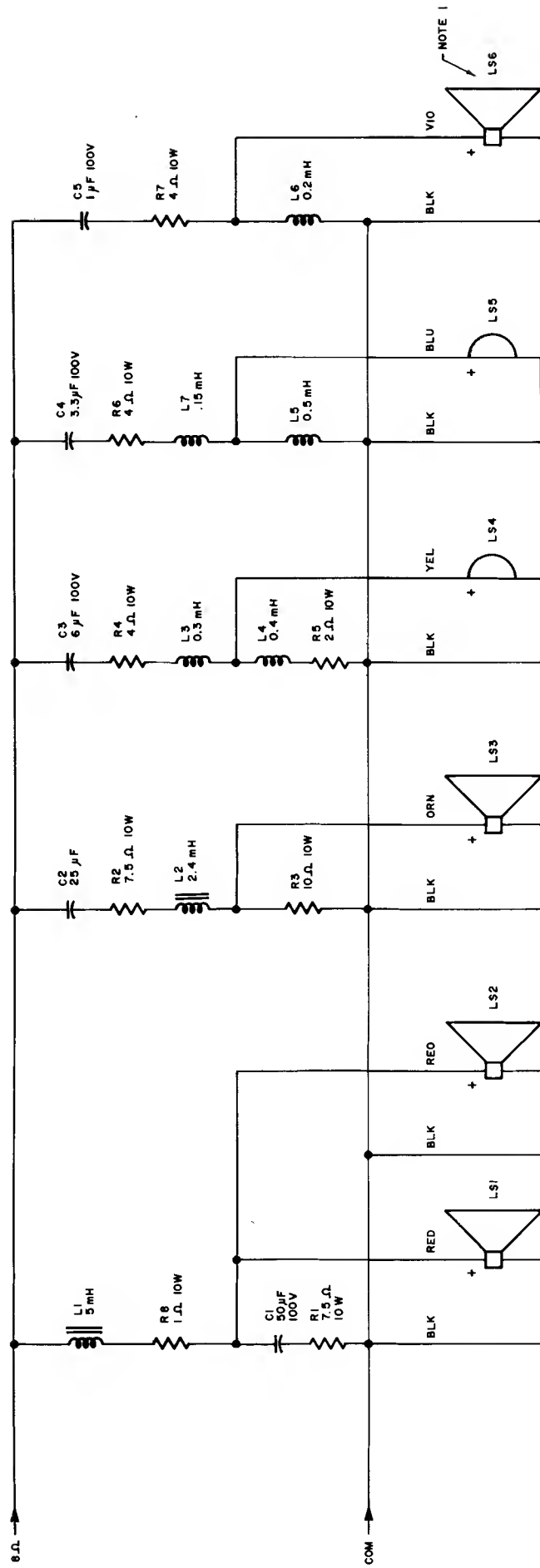

SYSTEM SCHEMATIC

SERVICE NOTES

Speaker element failure can be quickly located by using FM hiss at a low power level. Listen at each speaker to verify if all the speakers are at least working. A low power (1-5 watt) sine wave sweep 20-20kHz can be used as a quick check for distortion. A speaker element with obvious distortion must be replaced.

To determine if the speaker element is dead, remove the speaker and momentarily connect a 1.5 to 6V battery across the terminals. If no sound is heard, the speaker element must be replaced.

The crossover network must be inspected when burned out speaker elements are replaced. The network must also be inspected if a speaker element produces sound with the battery test but does not play when connected in the system. The woofer must be removed to get to the crossover. Check for bad connections, broken wires, etc. Be sure to check the resistors mounted on the plate underneath the printed circuit board. A broken lead on these resistors can also be the cause of intermittent or partial failure of the system.

When a system has been driven excessively hard by a "clipped" amplifier for long periods of time, the dome mid-range may appear to have weak or no output. In addition to a burned out mid-range, the 7 μ F capacitor may also be damaged. This will be evident if a new mid-range has been installed and also appears to have weak or no output.

Use only McIntosh replacement capacitors. These have been specially selected for low ESR.

Use RTV silicone rubber under replacement parts mounted on the printed circuit board. In addition to the solder connections, this insures a vibration free bond to the board.

The solid colored wire (other than black) always goes to the red marked terminal on the speaker. This is the positive terminal. If the polarity of a speaker is unknown, momentarily connect a 1.5 to 6V battery to the terminals. When the cone moves away from the magnet, it means the + terminal of the battery is connected to the + terminal of the speaker.

When installing speakers or crossover network in the cabinet, care must be taken to insure a tight air seal to the cabinet. Replace the black caulking material or foam gasket if necessary. Mortite caulking compound or equivalent could be substituted but care must be taken that it will not be visible after the part is installed.

If a woofer screw strips out in the wood of the cabinet, the speaker can be rotated and new mounting holes drilled.

After the system is reassembled, it must be checked for air leaks. This can be done by putting a 20Hz sine wave into the system at 50 watts (20 volts). By listening around the speakers closely for hissing sounds, areas can be located that must be sealed. The system must also be swept from 20Hz to 250Hz at 25 watts (14 volts) to insure there are no vibrations due to wires hitting the woofer cone, etc.

All defective parts must be packed well and returned to McIntosh Laboratory Loudspeaker Division.

REPLACEMENT PARTS

All parts not listed are common items obtainable from radio parts jobbers.

Replacement parts may be obtained when ordered by PART NUMBER from:

McIntosh Laboratory, Inc.
Customer Service Department
2 Chambers Street
Binghamton, New York 13903
(telephone 607-723-3512)

CAPACITORS

Symbol
Number

Description

Part
Number

MISCELLANEOUS ITEMS

C1	Elect.	50 μ F	100V	066-192	Terminal Red	084-086
C2	Elect.	25 μ F	100V	066-189	Terminal Black	084-087
C3	Elect.	6 μ F	100V	066-186	Shipping Carton	033-165
C4	Mylar	3.3 μ F	100V	064-117	Grille Cloth	031-002
C5	Mylar	1 μ F	250V	064-104	Front Panel Assy.	044-362

CHOKES

L1	Choke	5mH		122-124	Speaker Gasket 12" Woofer	094-092
L2	Choke	2.4mH		122-125	Speaker Gasket 2-1/4" Tweeter	094-096
L3	Choke	.3mH		122-159	Speaker Gasket 1-1/2" Dome	094-100
L4	Choke	.4mH		122-166	Speaker Gasket 8" Midrange	094-094
L5	Choke	.5mH		122-165	Network Gasket	094-106
L6	Choke	.2mH		122-158		
L7	Choke	.15mH		122-167		

RESISTORS

R1,2	Wirewound	7.5 Ω	10W	139-090		
R3	Wirewound	10 Ω	10W	139-089		
R4,6,7	Wirewound	4 Ω	10W	139-086		
R5	Wirewound	2 Ω	10W	139-085		
R8	Wirewound	1 Ω	10W	139-084		

LOUDSPEAKERS

LS1,2	12" Woofer			036-001		
LS3	8" Midrange			036-025		
LS4,5	1-1/2" Dome Midrange			036-016		
LS6	2-1/4" Tweeter			036-012		

McIntosh

McINTOSH LOUDSPEAKER DIVISION
2 CHAMBERS ST., BINGHAMTON, N.Y. 13903



SERVICE BULLETIN

REPLACEMENT OF 8" LOUDSPEAKER 036-002

MODEL: ML-2C and ML-2M Loudspeakers.

PURPOSE OF MODIFICATION: To maintain the same acoustic output.

WHAT UNITS ARE AFFECTED: ML-2C Serial No. L1C001 through L1C429.
ML-2M Serial No. L1D001 through L1D145.

WHEN MODIFICATION SHOULD BE MADE: When replacing defective 036-002 8" loudspeaker.

McINTOSH MODIFICATION KIT: No kit available.

PARTS REQUIRED:

QUANTITY	PART NUMBER	DESCRIPTION
1	139-090	Wirewound Resistor: 7.5Ω, 10W
1	036-025	8" Loudspeaker

PROCEDURE:

- Step 1 Remove rear panel.
- Step 2 Locate 10Ω, 10 watt resistor in series with the 8" loudspeaker. Remove and replace with 7.5Ω, 10 watt resistor.
- Step 3 Replace rear panel.

(over)

