

METER SECTION PRINTED CIRCUIT BOARD
043 - 711

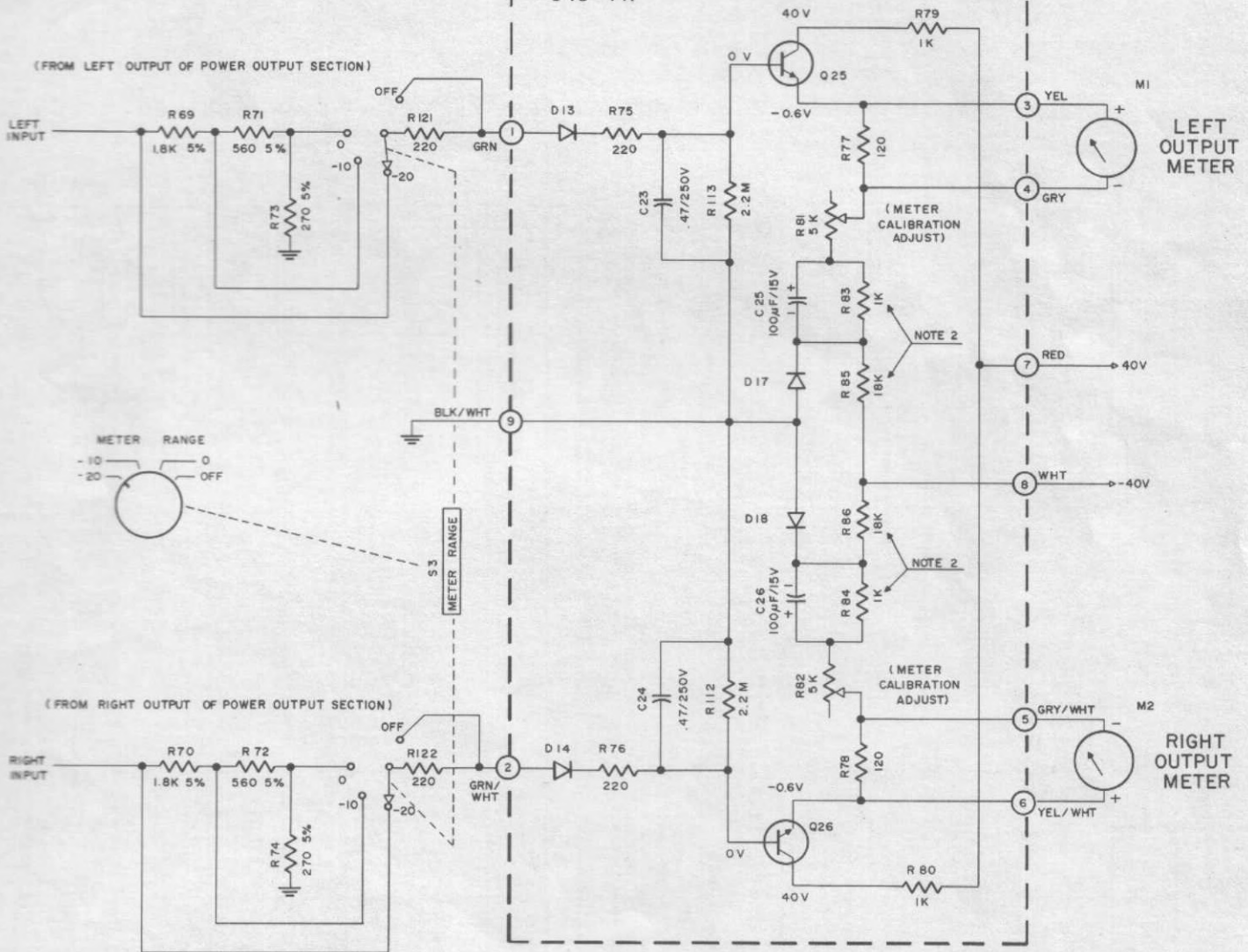

METER SECTION

INPUT SECTION PRINTED CIRCUIT BOARD

043 - 708

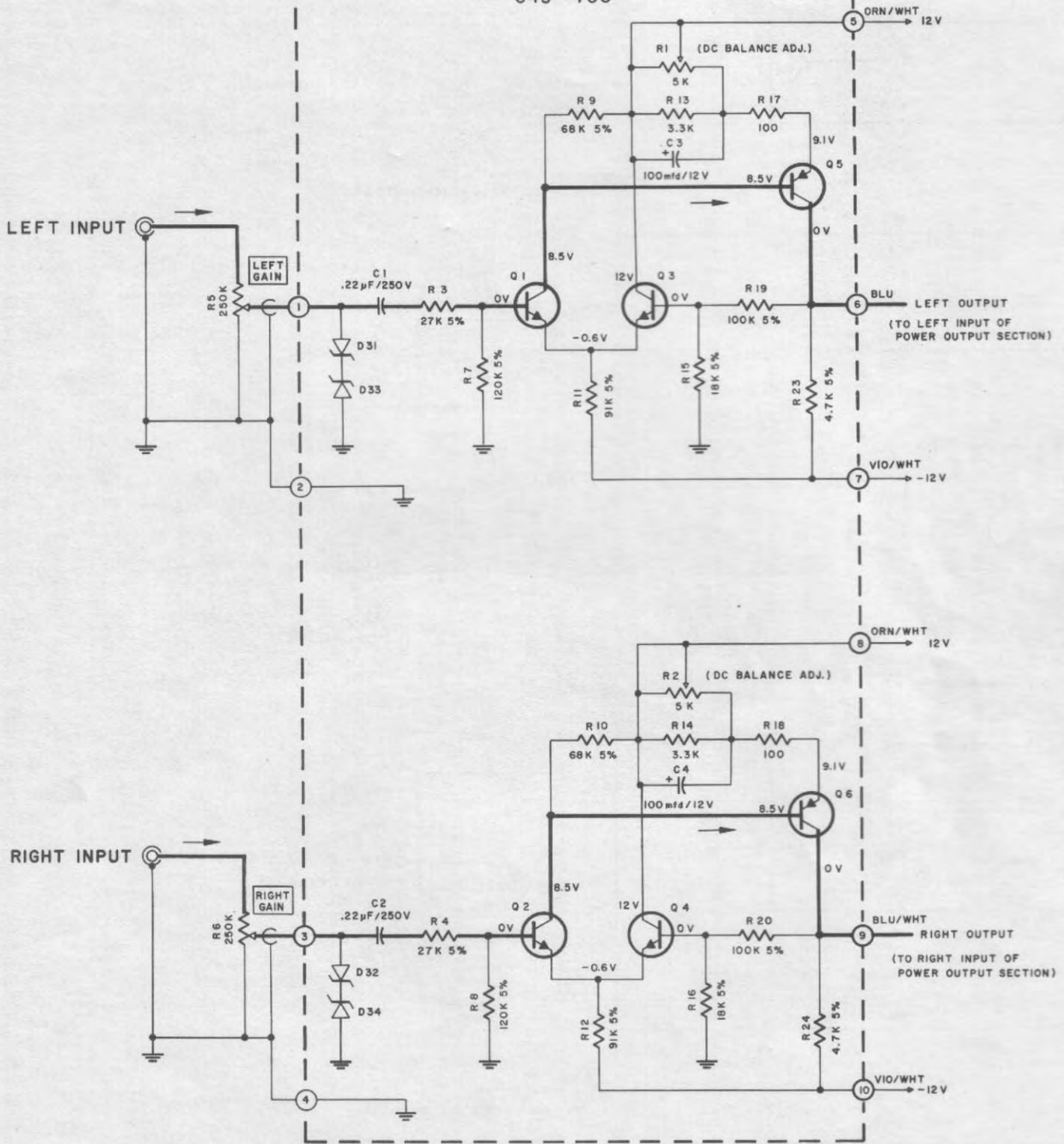

HEAVY LINE SHOWS PRIMARY SIGNAL PATH

INPUT SECTION

MC 2505

154 - 281

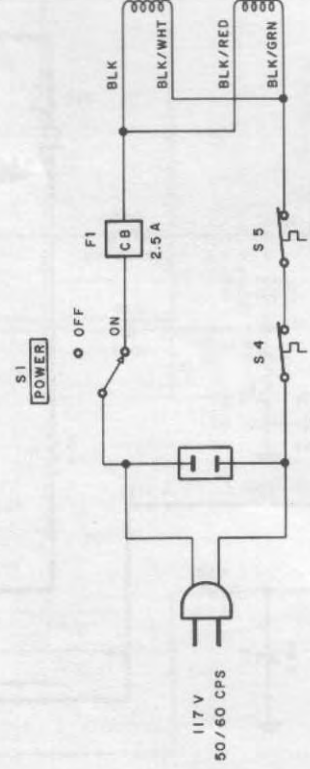
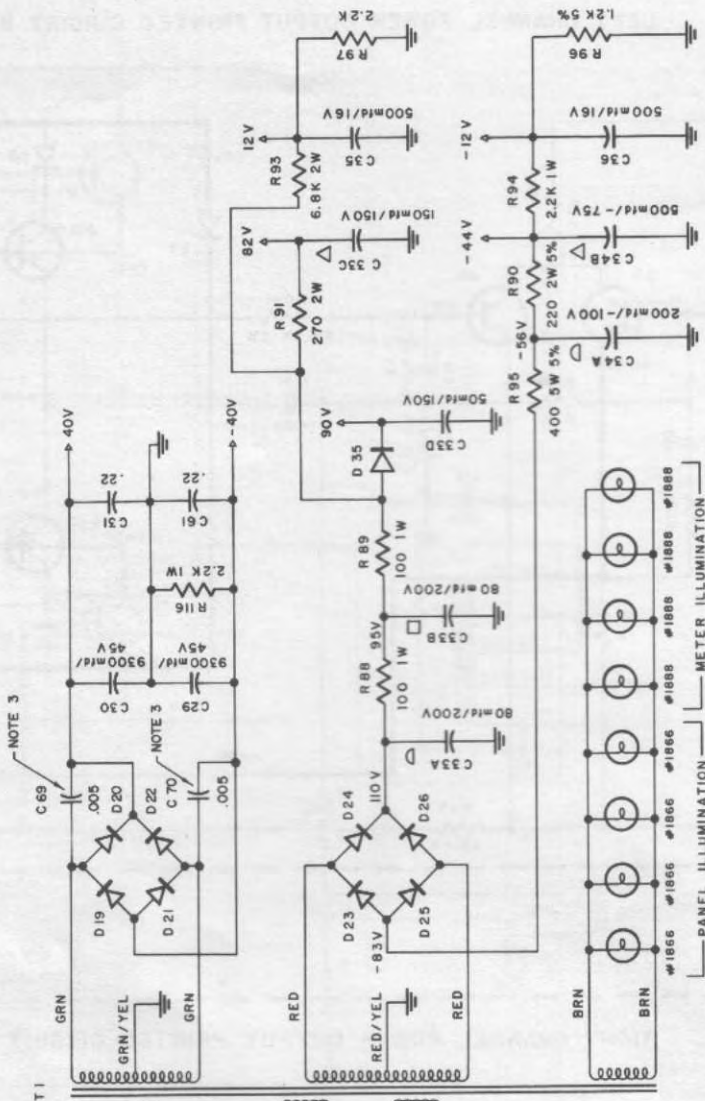

POWER SUPPLY SECTION

MC 2505

154 - 386

LEFT CHANNEL POWER OUTPUT PRINTED CIRCUIT BOARD 043-804

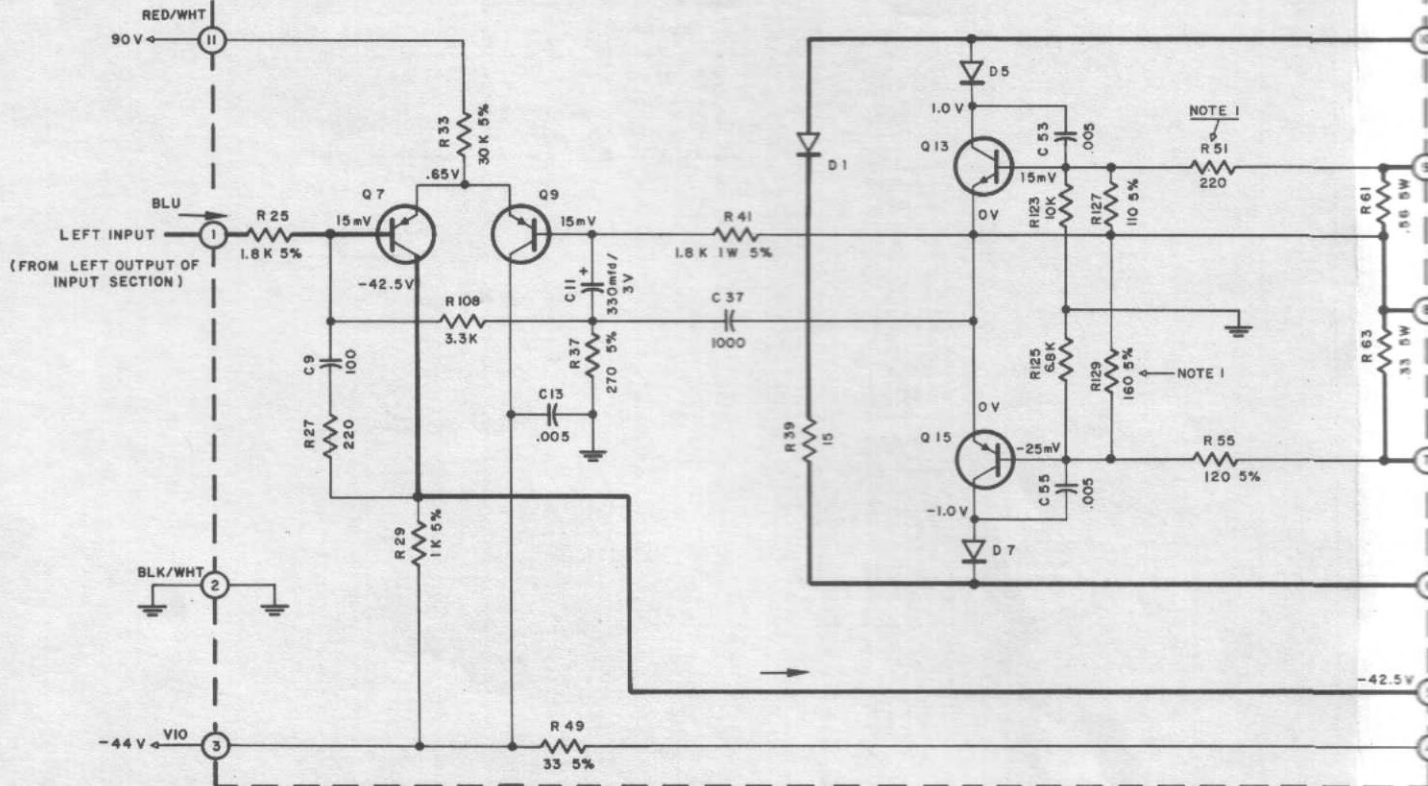

RIGHT CHANNEL POWER OUTPUT PRINTED CIRCUIT BOARD 043-804

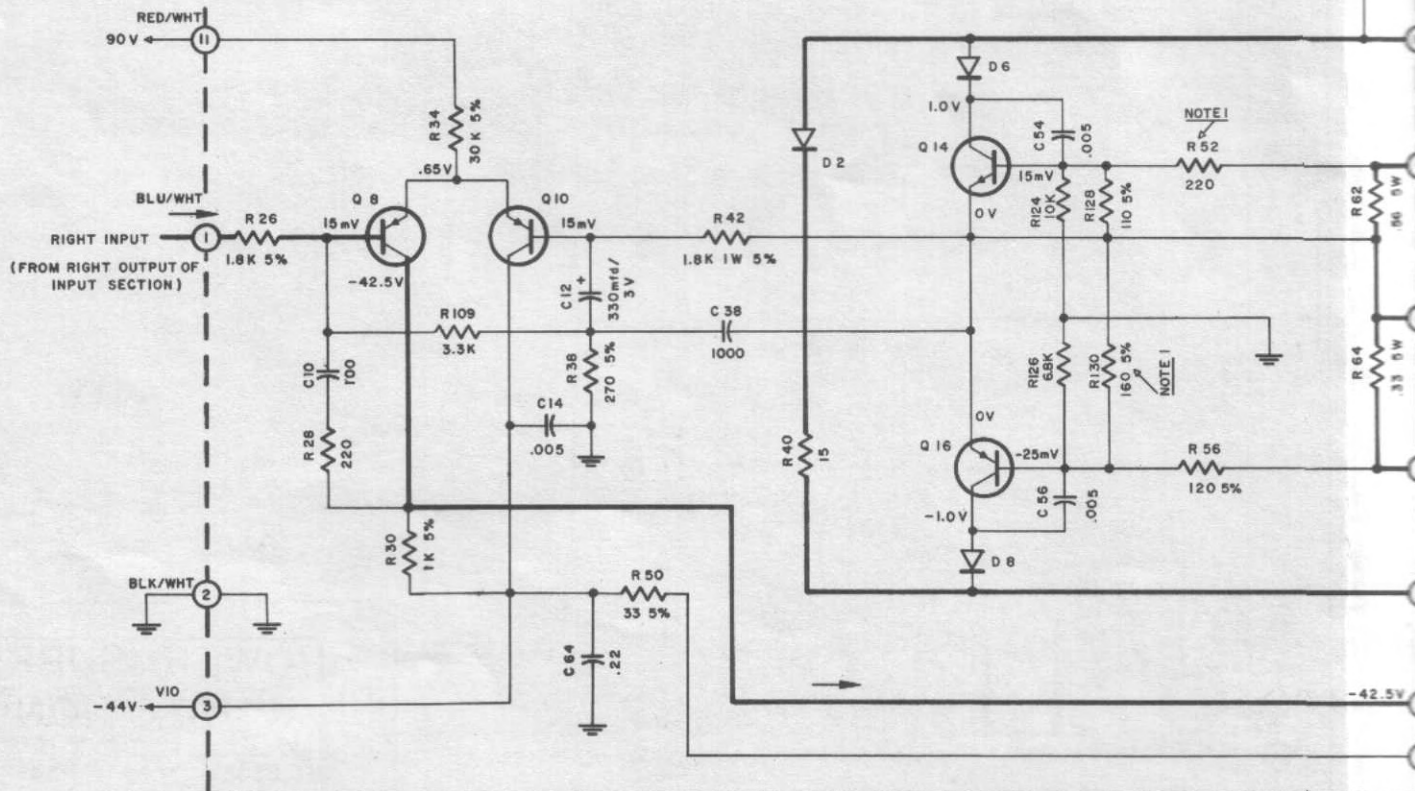

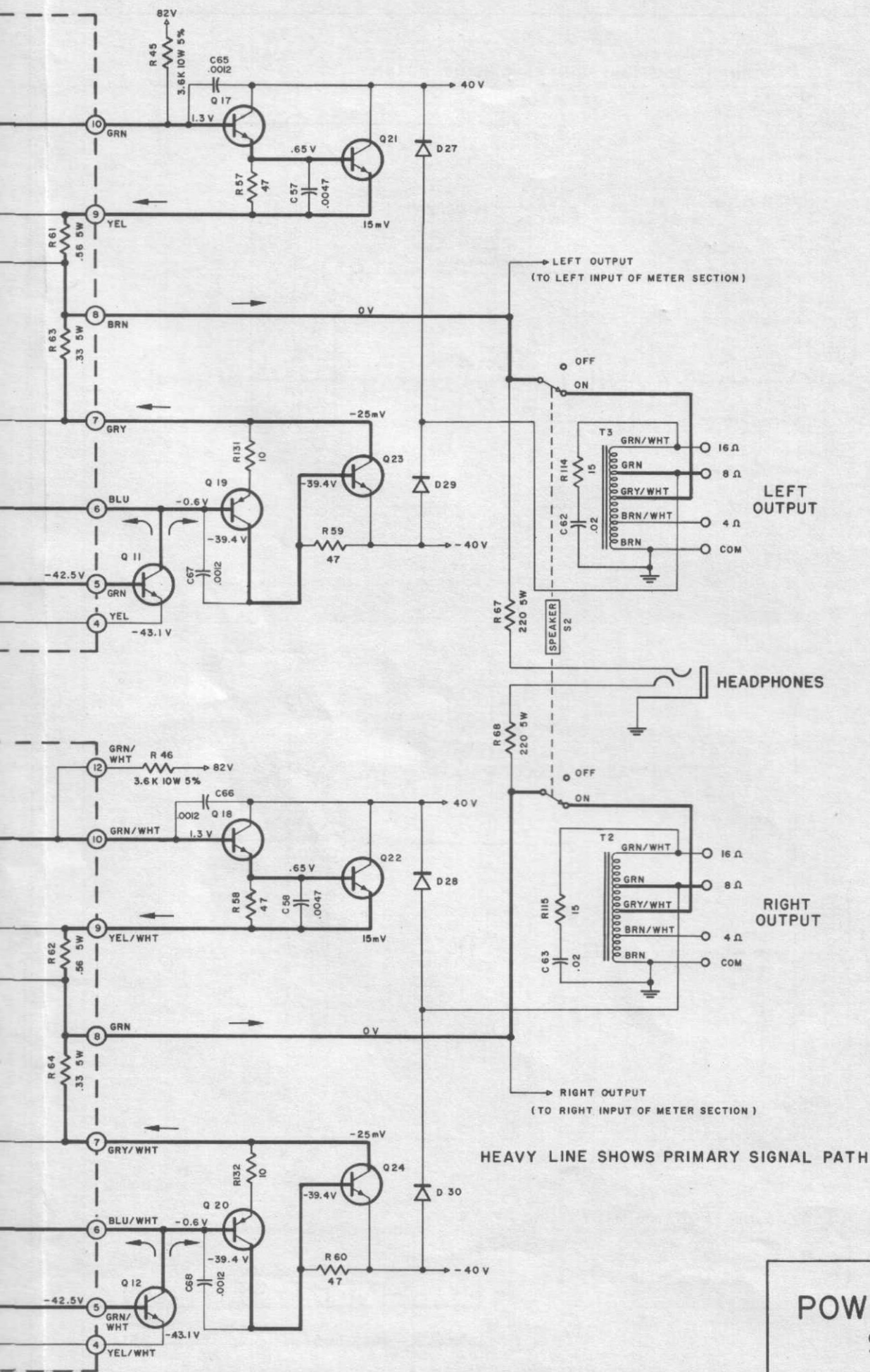

POWER OUTPUT SECTION

McIntosh

MC-2505 SOLID STATE AMPLIFIER

Page -1-

Servicing the McIntosh MC-2505 solid state amplifier is easy. Transistor and tube type amplifiers have much in common. It is necessary to learn only a few basic principles.

1. Being a solid state amplifier, the circuits are in operation the moment the instrument is turned on. It is important to be certain that all circuits are operating properly before applying full line voltage. If some circuits are not operating properly, it is possible to damage additional circuit components. Therefore, when a McIntosh MC-2505 comes in for service, NEVER JUST PLUG IT IN AND TURN IT ON. Turn the MC-2505 on/off switch on, but turn the speaker switch off. Always use a Variac or Powerstat. Plug the amplifier into the Variac, but set the Variac output to zero volts. Bring the line voltage to the amplifier up very slowly. As you do so, monitor the output voltage on each channel. This is done with a VTVM. Connect the VTVM common lead to the chassis and the probe to the point shown:

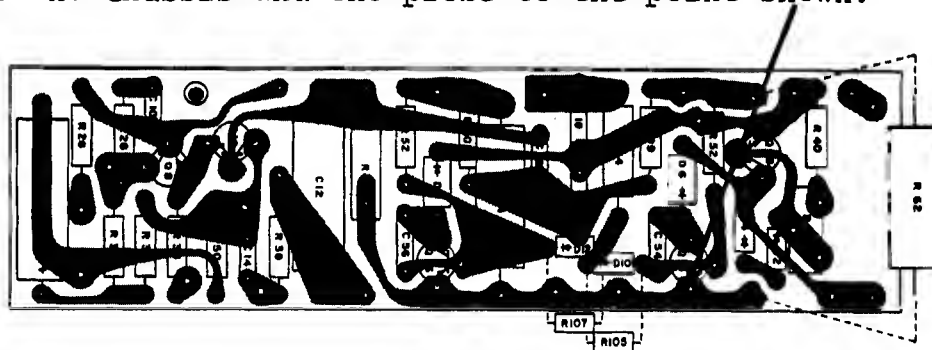

POWER OUTPUT PRINTED CIRCUIT BOARD

Set the VTVM on about a 15 volt positive DC scale. Set the needle of the VTVM to the center of the scale rather than to zero. As the line voltage to the amplifier is slowly increased, the VTVM needle will swing positive a few volts, then back past the center position, then slightly negative, then return to center position. This complete cycle will occur before the line voltage to the

amplifier reaches 30 volts. Raise the line voltage from zero to 30 volts very slowly. Alternate the VTVM probe between the two channels. There may be trouble in only one channel. The channel without the trouble would give a correct indication on the VTVM. So it is necessary to monitor both channels as the amplifier is being turned on.

2. This step tells how to adjust the bias. It applies only to amplifiers bearing 10K01 through 14K84. Amplifiers bearing serial number 14K85 and up have no bias adjustments to be made. If the amplifier has turned on with no indication of trouble, the next step is to set the bias. By means of the bias pot on the power output printed circuit board, adjust the bias for 40 millivolts. Do this for each channel. This adjustment should be made when the amplifier is cold. Make it within the first minute or so after the amplifier has been turned on. The bias will vary somewhat as the amplifier warms up. Do not re-adjust the bias. The bias adjustment is made with the VTVM connected as shown:

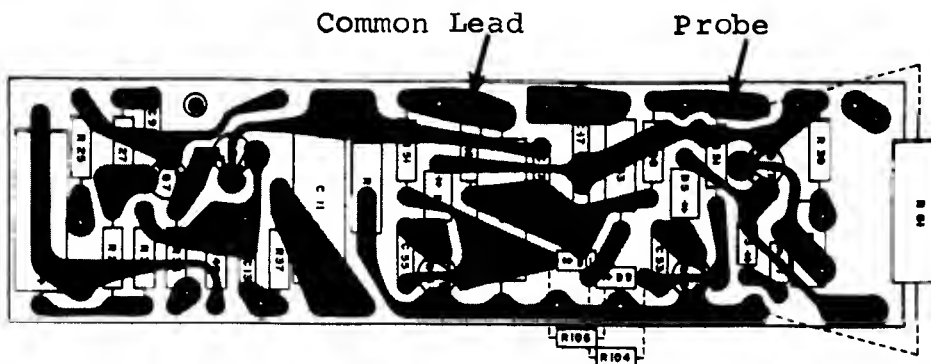

POWER OUTPUT PRINTED CIRCUIT BOARD

3. If there is trouble in one channel, you will not see the indication on the VTVM described in point 1. Stop right there. There are basically three possibilities of incorrect indication. The VTVM needle may not move at all, it may continue to swing positive, or it may continue to swing negative.

McIntosh

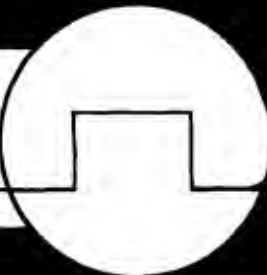

Page -3-

4. Regardless of the incorrect indication, it is usually not difficult to find the source of trouble. Turn the line voltage completely off. Discharge the large filter capacitors. Do not discharge the capacitors by shorting them directly to the chassis. Because of the arcing that will occur, the chassis will be marred. The proper way to discharge these capacitors is with a resistor. Use a resistor of at least a two watt rating whose value is approximately 5 to 15 ohms. Hold it across each of the large filters. In this way the power supply will be safely discharged. Failure to discharge the power supply before working on the amplifier could cause several transistors to be destroyed.

5. After the power supply is discharged, check each transistor. This is done quite easily with the VTVM. CAUTION: USE VTVM SUCH AS THE RCA SENIOR VOLTOHMYST. Do not use older 1,000 ohms per volt VOM. This type of instrument may destroy the transistor by introducing excessive current into the transistor. Set the VTVM to measure ohms; after the power supply is discharged, check each transistor. Set the VTVM to measure ohms; use the "R x 1" scale. Measure across each junction of the transistor. Measure from base to collector, base to emitter, emitter to collector, emitter to base, collector to emitter, and collector to base. Also measure from the case of the transistor to ground. In no case should there be a direct short. In most cases, only one channel of the amplifier will be defective. Therefore, until you become familiar with the readings to expect in each case, compare the defective channel with the good channel. Although a defective transistor will usually be indicated by a direct short, this is not always the case. It is possible for a difference of only 2 or 3 ohms to indicate a defective transistor. For example, if a transistor in the defective channel reads 12 ohms from one junction to another, and the similar transistor in the good channel reads 10 ohms, the transistor which reads 12 ohms is probably defective.



McIntosh

Page -4-

6. If the transistors all measure correct, check the power resistors at the emitter and collector of the output transistors. These will have a very low resistance of about .33 ohms to .56 ohms. You may find that one of these resistors has opened up.
7. On units having a bias potentiometer, always check it for continuity. Be certain that it has not opened up.
8. After replacing a defective part, always turn the amplifier on as described in point 1. Otherwise, you may damage more parts. For example, you may find a shorted output transistor. You will replace the transistor. If there are other defective parts, that you do not yet know about, and you turn the amplifier on directly, in all probability, you will damage the new transistor that you have just installed.
9. Before working on a solid state amplifier, ALWAYS discharge the power supply as described in point 4. If you do not do so, and then begin probing with a soldering aid, VTVM probe, or what have you, in all probability you will damage some transistors when you accidentally short from certain places to ground!
10. If the difficulty is not located as described in points 5, 6, and 7 you may turn the amplifier partially on. Bring the line voltage up to 25 or 30 volts. This will be enough voltage to enable you to signal-trace, compare voltages between the good channel and the defective one, etc. without damaging any components.

MC-2505 SOLID STATE AMPLIFIER

Page -1-

Although the MC2505 is rated at 50 watts (sine wave) per channel, it will normally put out at least 75 watts per channel. However, it is possible to drive the amplifier even harder than this. The following modification will improve the power output capabilities when the amplifier is loaded with a mis-matched load. It will also eliminate the possibility of any noise from the power supply being heard through the speakers when the amplifier is turned on and off.

This modification pertains to amplifiers bearing serial numbers 10K01 through 11K54. Amplifiers having a higher serial number than 11K55 have been modified.

It is necessary to change 2 resistors and 2 capacitors on each power output printed circuit board. A resistor is added to the board. In addition, 1 resistor is changed in the power supply and a diode and capacitor are added.

Add a 3.3K resistor

Change R-99 from 220 ohms
to 130 ohms

Change R-62 from
.56 ohms to .33 ohms

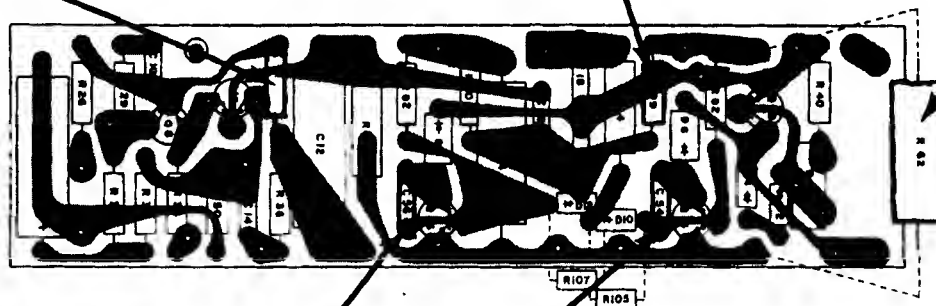

Change C-56 and C-54
from .01 mfd to .047 mfd

The right channel power output printed circuit board is shown. Do likewise on the left channel board.

Add a .22mfd, 250 volt capacitor from the -40 volt supply to ground as shown below:

McIntosh

Page -2-

Connect the Capacitor
Here

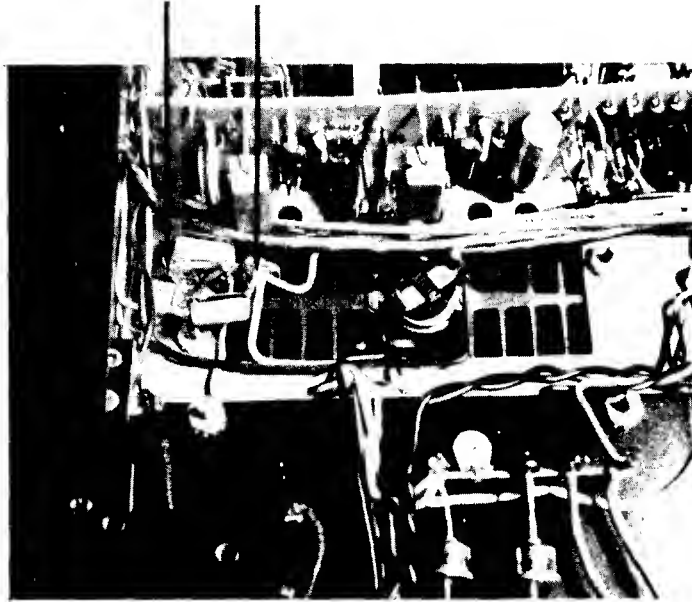

There are two terminal strips mounted on the chassis between the large electrolytic filter capacitors. There are four 2 watt resistors and 1 5 watt resistor soldered to these terminal strips. There is a red/white wire connected to one side of a terminal strip at R91. R91 is now a 270 ohm, 2 watt resistor. Change this resistor to a 220 ohm, 2 watt resistor. Remove the red/white wire that is connected here. Connect it to C-33D as shown in the picture. Also, from C-33D and the junction where the wire was formerly connected, install a diode.

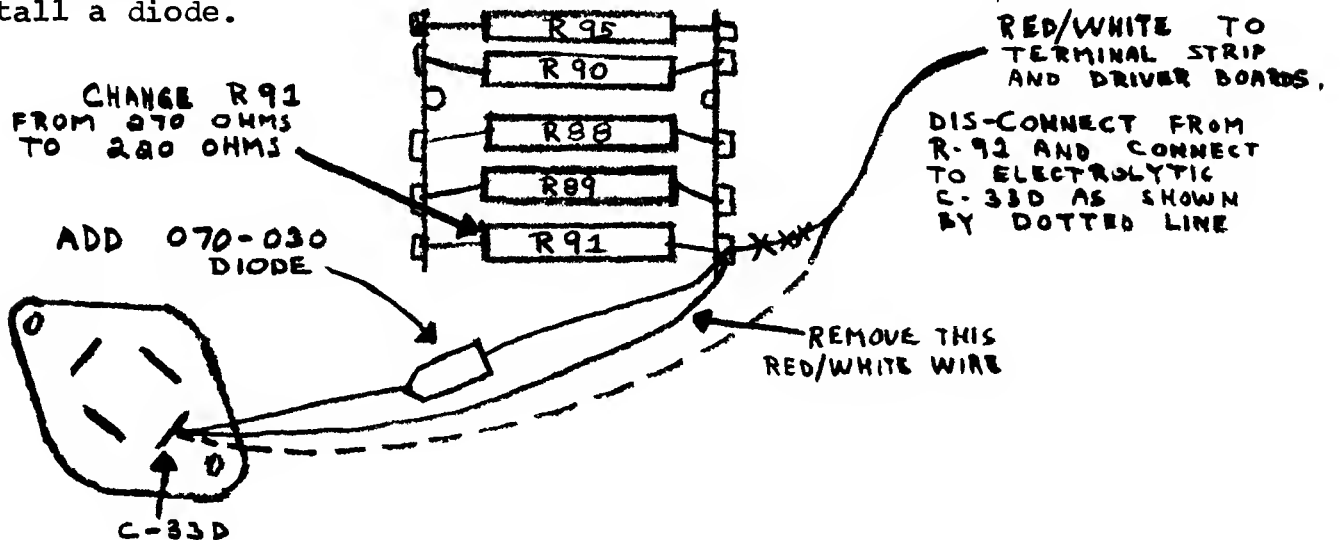

McIntosh

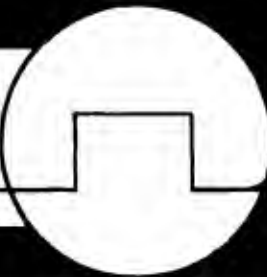

Page -3-

After the modification is made, no adjustments are necessary.

Parts required:

2 - .33 ohm, 5W resistors	McIntosh part #139-036
2 - 130 ohm, 1/2W resistors	McIntosh part #136-073
2 - 3.3K ohm, 1/2W resistors	McIntosh part #136-131
1 - 220 ohm, 2W resistor	McIntosh part #139-042
4 - .047mfd, 250 volt capacitors	McIntosh part #064-044
1 - .22mfd, 250 volt capacitor	McIntosh part #064-043
1 - Diode	McIntosh part #070-030

When ordering these parts, ask for McIntosh parts kit number 9043-664.

The following schematics show the changes:

