

McIntosh

C 22



SERVICE INFORMATION

STARTING WITH SERIAL NO. 10A01

McINTOSH LABORATORY INC. 2 CHAMBERS STREET BINGHAMTON, NEW YORK

C 22

ELECTRICAL SPECIFICATIONS

Frequency Response

+0.5 to -0.5 dB, 20Hz to 20,000Hz

Distortion

Less than 0.2% at 10 volts output

Less than 0.02% at 3 volts output

Input Sensitivity (phono 1, phono 2, tape head)

2 millivolts for 2.5 volts output at 1kHz

Input Sensitivity (Microphone)

2.5 millivolts for 2.5 volts output

Input Sensitivity (aux, tape, tuner)

0.25 volts for 2.5 volts output

Hum And Noise (phono 1, phono 2, tape head)

74 dB below 10 millivolts input

Hum And Noise (aux, tape, tuner)

85 dB below rated output

Output (main)

2.5 volts with rated input. Up to 10 volts can be developed without distortion.

Output (tape)

0.25 volts with rated input. Phono input signal of 10 millivolts produces 1.25 volts output.

Output (L & R)

1.0 volts with rated input on both channels. A level control adjusts output.

Bass Control

±20 dB at 20Hz

Treble Control

±20 dB at 20,000Hz

LF Filter

Flat or sharp cutoff below 50Hz (down 30 dB @ 20Hz).

HF Filter

Flat or sharp cutoff above 5000Hz (down 30 dB @ 20,000Hz).

Unless otherwise specified, resistance values are in ohms, 1/2 watt, and 10% tolerance. Capacitance values smaller than 1 are in microfarads (μF); values greater than 1 are in picofarads (pF). Resistors marked with * are 1/4W.

The terminal numbering of rotary switches and printed circuit board wires is for reference only.

All voltages are measured under the following conditions:

1. Use of an 11 megohm input impedance VTVM
2. All voltages $\pm 10\%$ with respect to ground
3. AC input at 117 volts, 50/60 cycles
4. No signal at input terminals
5. Front panel controls at normal positions

LEFT CHANNEL

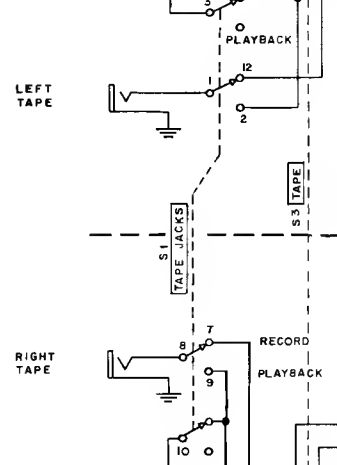
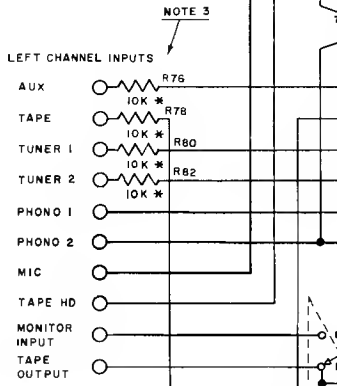

RIGHT CHANNEL

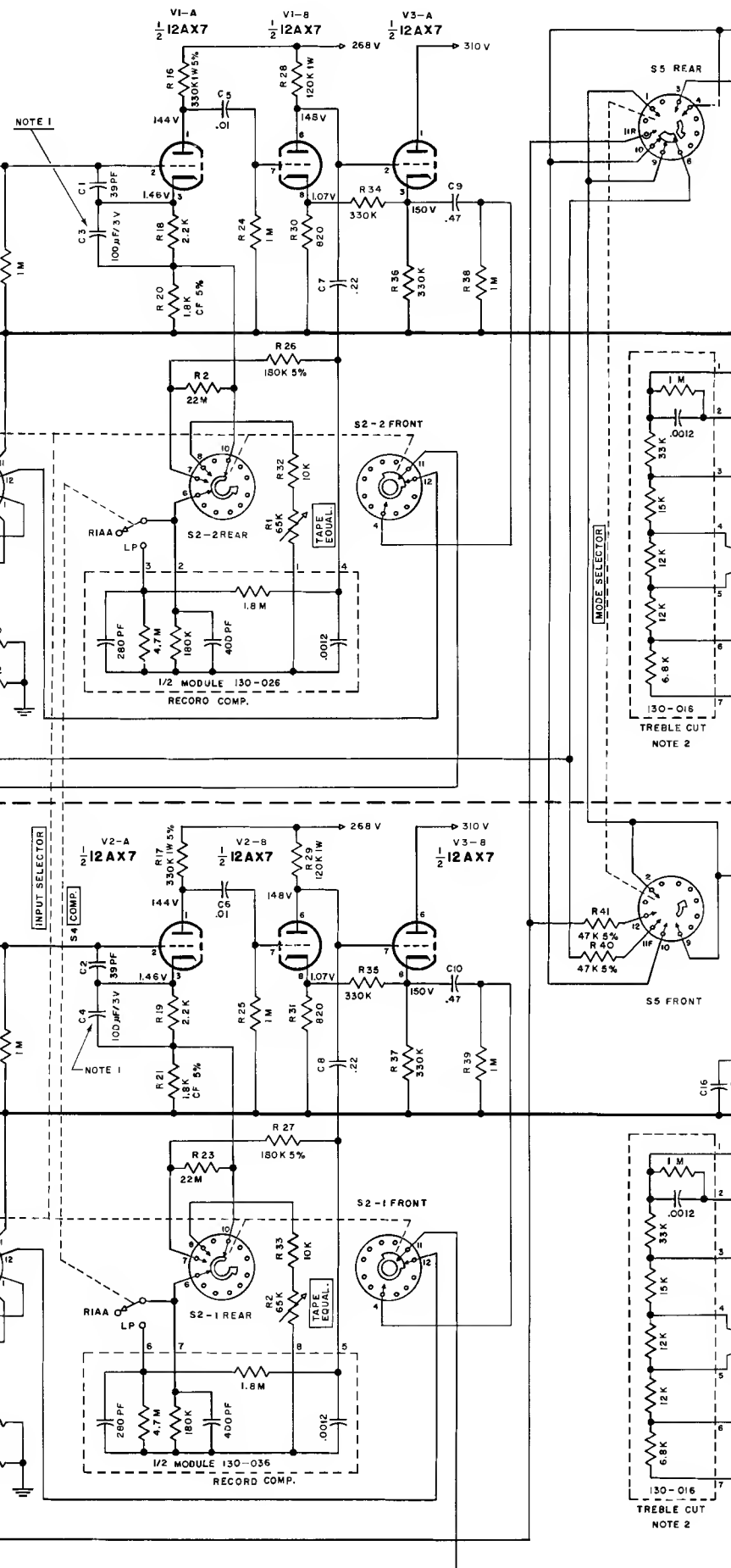
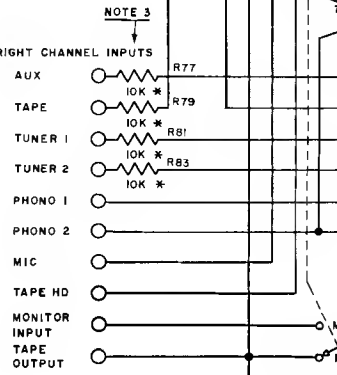

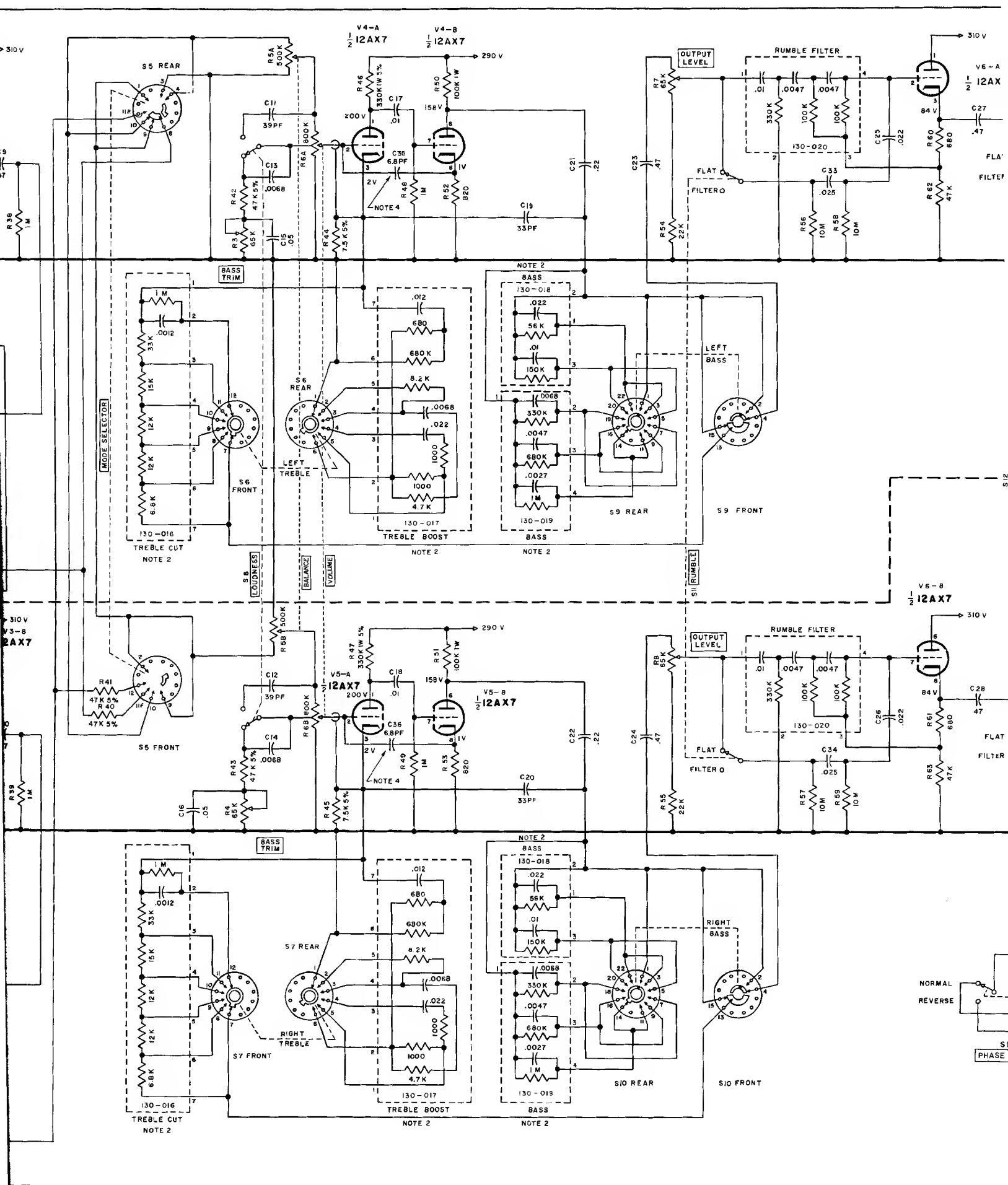

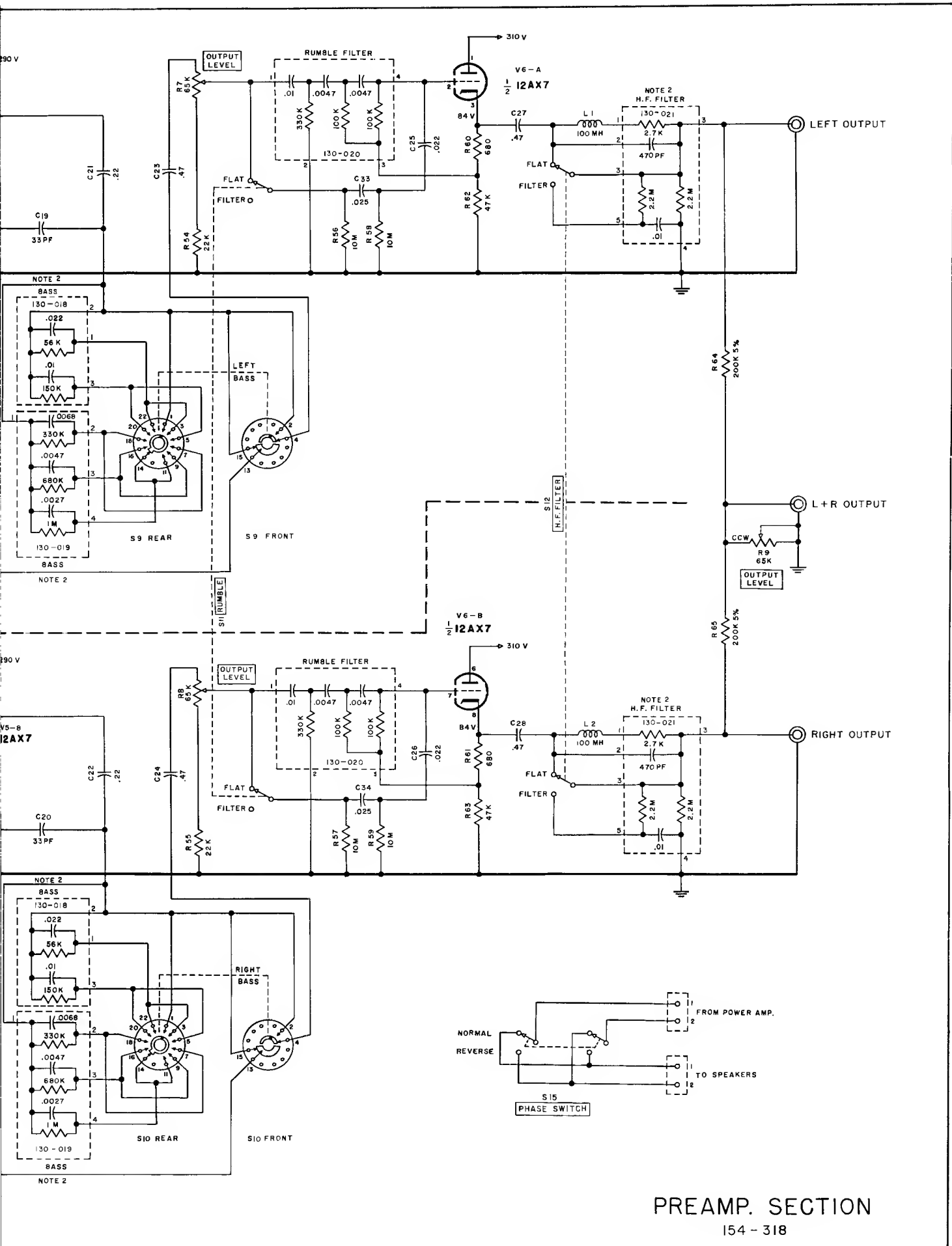

SCHEMATIC NOTES

1. In early units C3 & 4 were 50 μ F.
2. C22's built before 1965 used circuit modules made by Erie Electronics. In 1965, we changed to Sprague Electric Co. The Sprague modules are electrically equivalent to the Erie modules but differ mechanically. The newer Sprague modules are used for replacement when servicing early C22 units. For data on replacing the old Erie modules with the Sprague modules, refer to McIntosh Service Bulletin #108.
3. In early units R76 thru R83 do not appear.
4. In early units C35 & 36 do not appear.
5. In early units R67 was 50 ohms.

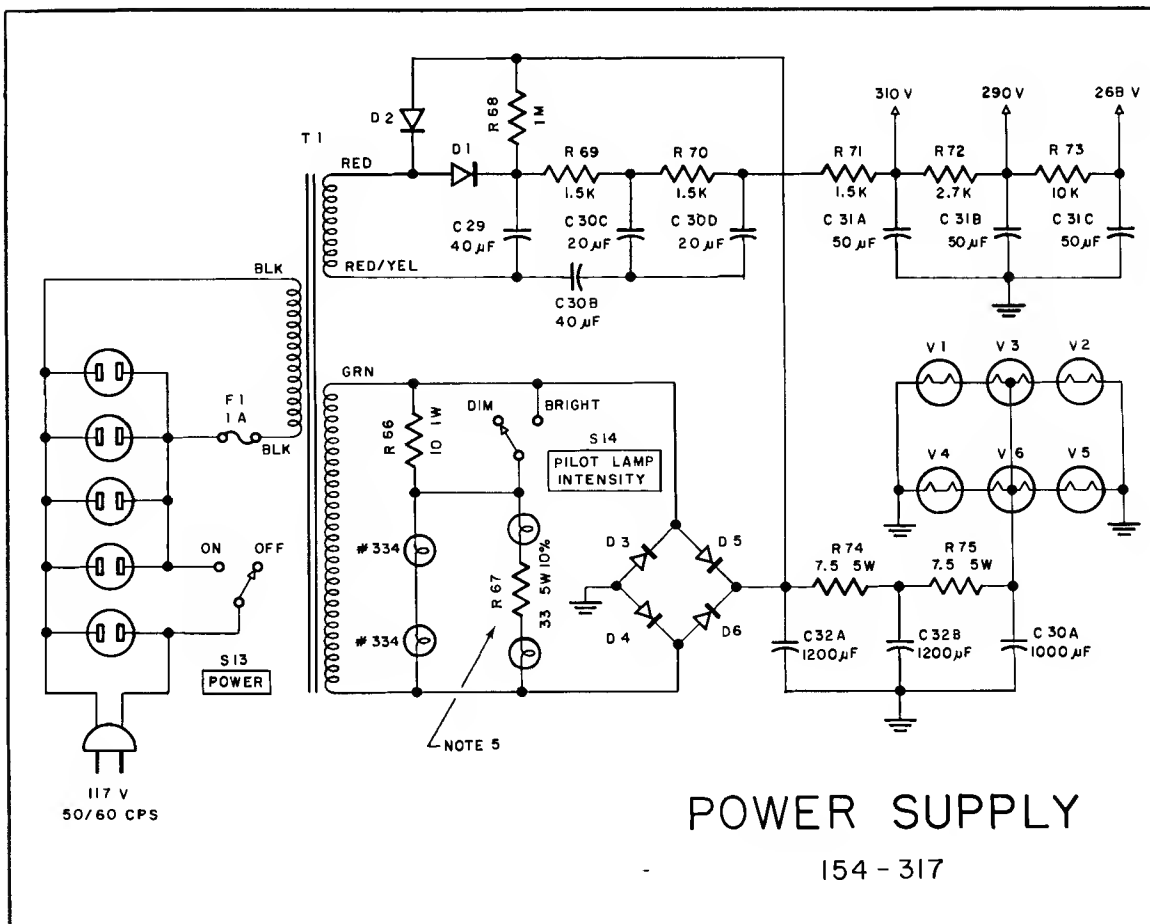

REPLACEMENT

All parts not listed are available from radio parts jobbers.

Replacement parts may be obtained by PART NUMBER from:

McIntosh Laboratory
Customer Service
2 Chambers Street
Binghamton, New York
(telephone 607-733-1111)

Symbol Number	Description	Value
CAPACITORS		
C3,4	Elect.	10 μ F
C29	Elect.	40 μ F
C30	Elect.	20 μ F
C30B	Elect.	40 μ F
C30C	Elect.	20 μ F
C30D	Elect.	20 μ F
C31	Elect.	50 μ F
C31A	Elect.	50 μ F
C31B	Elect.	50 μ F
C31C	Elect.	50 μ F
C32	Elect.	1200 μ F
C32A	Elect.	1200 μ F
C32B	Elect.	1200 μ F
C30A	Elect.	1000 μ F
DIODES		
D1,2	Se. rectifier	
D3,4	Si. rectifier	
D5,6	Si. rectifier	
FUSES		
F1	Fuse	1 amp
CHOKES		
L1,2	Choke	100 mH
POTENTIOMETERS		
R1,2	Tape equal.	
R1,2	Tape equal.	
R3,4	Bass trim	
R3,4	Bass trim	
R5	Balance control	
R6	Volume control	
R7,8,9	Output level	
R7,8,9	Output level	
RESISTORS		
R16,17	Low noise	33 Ω
R20,21	Low noise	1 Ω
R46,47	Low noise	33 Ω
R67	Wirewound	33 Ω
R74,75	Wirewound	7.5 Ω

REPLACEMENT PARTS

All parts not listed are common items obtainable from radio parts jobbers.

Replacement parts may be obtained when ordered by PART NUMBER from:

McIntosh Laboratory Inc.
Customer Service Department
2 Chambers Street
Binghamton, New York 13903
(telephone 607-723-3512)

CAPACITORS

Symbol Number	Description	Part Number
C3,4	Elect. 100 μ F 3V	066-047
C29	Elect. 40 μ F 200V	066-049
C30	Elect. 1000/40/20/20 μ F 25/200/350/350V	066-037
C31	Elect. 50/50/50 μ F 350/350/300V	066-033
C32	Elect. 1200/1200 μ F 30/30V	066-029

DIODES

D1,2	Se. rectifier	070-005
D3,4	Si. rectifier	070-014
D5,6	Si. rectifier	070-014

FUSES

F1	Fuse 1 amp	089-002
----	------------	---------

CHOKES

L1,2	Choke 100 mH	122-004
------	--------------	---------

POTENTIOMETERS

R1,2	Tape equal. (1/2 Dia.)	134-059
R1,2	Tape equal. (5/8 Dia.)	134-186
R3,4	Bass trim (1/2 Dia.)	134-059
R3,4	Bass trim (5/8 Dia.)	134-186
R5	Balance control	134-061
R6	Volume control	134-060
R7,8,9	Output level (5/8 Dia.)	134-186
R7,8,9	Output level (1/2 Dia.)	134-059

RESISTORS

R16,17	Low noise 330K 5% 1W	144-005
R20,21	Low noise 1.8K 5% 1/2W	144-002
R46,47	Low noise 330K 5% 1W	144-005
R67	Wirewound 33 ohm 10% 5W	139-007
R74,75	Wirewound 7.5 ohm 10% 5W	139-010

SWITCHES

S1	Tape jacks switch	146-053
S2	Input selector switch	146-049
S3	Tape switch	148-006
S4	Comp. switch	148-006
S5	Mode selector switch	149-108
S6,7	Treble control switch	146-052
S8	Loudness switch	148-006
S9,10	Bass control switch	146-051
S11	Rumble switch	148-006
S12	H.F. filter switch	148-006
S13	Power switch	148-005
S14	Pilot lamp switch	148-003
S15	Phase switch	148-007

TRANSFORMERS

T1	Power transformer	159-019
----	-------------------	---------

MODULES

Treble cut	130-016
Treble boost	130-017
Bass, upper	130-018
Bass, lower	130-019
Rumble filter	130-020
H.F. filter	130-021
Phono equalization	130-026

LAMPS

#334 (indicator)	058-003
Festoon (indicator glass)	058-033

FRONT PANEL & TRIM

Front panel	043-359
Front panel glass	016-034
End cap, right	018-043
End cap, left	018-044
Volume control knob	043-253
Mode selector knob	043-253
Input selector knob	043-253
Balance knob	043-253
Bass control knob	043-428
Tape jacks knob	043-428
Treble control knob	043-428
Rocker switch knob	090-007
Level set knob	090-010

SWITCHES

S1	Tape jacks switch	146-053
S2	Input selector switch	146-049
S3	Tape switch	148-006
S4	Comp. switch	148-006
S5	Mode selector switch	149-108
S6,7	Treble control switch	146-052
S8	Loudness switch	148-006
S9,10	Bass control switch	146-051
S11	Rumble switch	148-006
S12	H.F. filter switch	148-006
S13	Power switch	148-005
S14	Pilot lamp switch	148-003
S15	Phase switch	148-007

TRANSFORMERS

	Power transformer	159-019
--	-------------------	---------

MODULES

	Treble cut	130-016
	Treble boost	130-017
	Bass, upper	130-018
	Bass, lower	130-019
	Rumble filter	130-020
	H.F. filter	130-021
	Phono equalization	130-026

LAMPS

	#334 (indicator)	058-003
	Festoon (indicator glass)	058-033

FRONT PANEL & TRIM

	Front panel	043-359
	Front panel glass	016-034
	End cap, right	018-043
	End cap, left	018-044
	Volume control knob	043-253
	Mode selector knob	043-253
	Input selector knob	043-253
	Balance knob	043-253
	Bass control knob	043-428
	Tape jacks knob	043-428
	Treble control knob	043-428
	Rocker switch knob	090-007
	Level set knob	090-010

MOUNTING SYSTEM

	Shelf bracket (right)	043-592
	Shelf bracket (left)	043-593
	Mounting template #100	038-179
	Hardware package	043-448

MISCELLANEOUS ITEMS

	Line cord	170-021
	Fuse holder	178-001
	Shipping carton	033-027
	Owners manual	038-027
	Plastic feet	017-041
	Shorting plug	127-001
	Indicator glass	016-036
	Audio cable (6')	170-015
	Audio cable (1 phone, 1 phono)	170-016

20C0425S6-8M270

McIntosh

MODEL NUMBER: C 8, C 11, C 22

DATE: APRIL 1965

MODIFICATION: Replace the selenium rectifier with silicon rectifiers. These silicon rectifiers have much longer life.

DESCRIPTION: The original selenium rectifier in the C 8 is replaced by two (2) silicon rectifiers; the original selenium rectifier in the C 11 and C 22 is replaced by four (4) silicon rectifiers. The rectifiers are McIntosh part number 070-014, or any 50 PIV 750 MA rectifiers.

PROCEDURE: The selenium rectifier is replaced by a terminal strip and the new silicon rectifiers are installed as shown in the following diagrams.

NOTE THAT TERMINAL STRIPS ARE REQUIRED

C 8

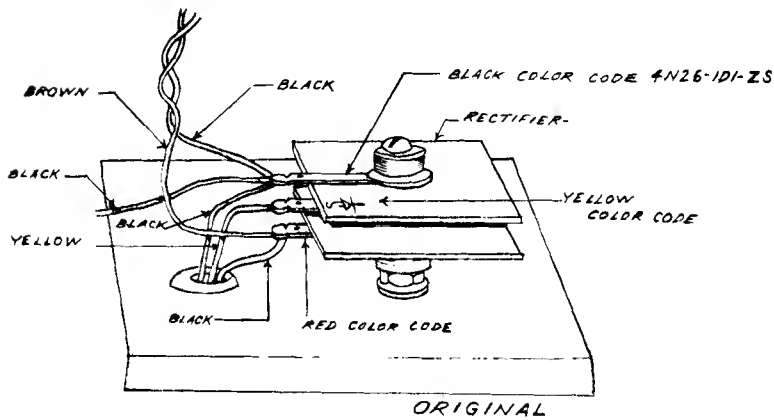

RECTIFIERS

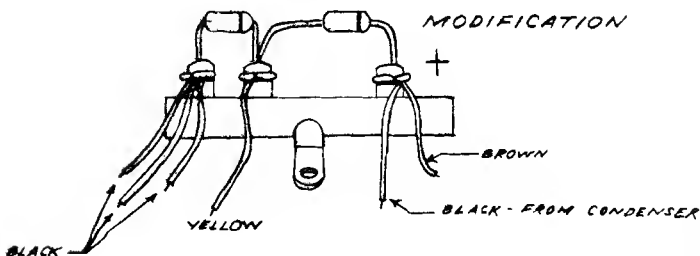

C 11, C 22

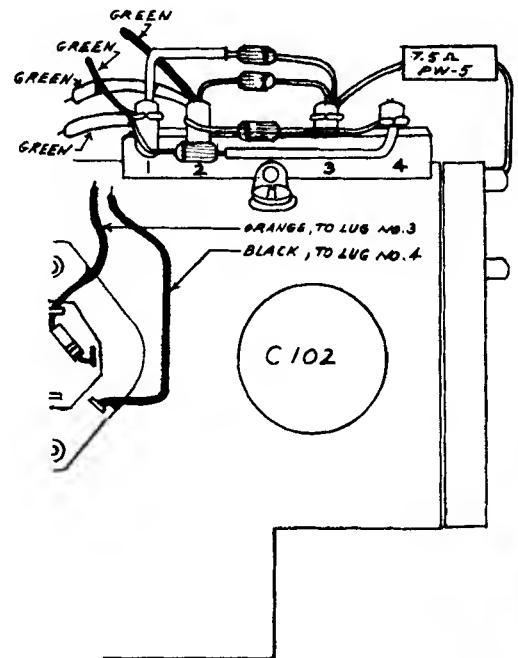

McIntosh

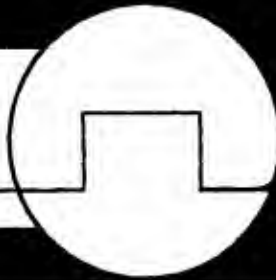

DATE: NOVEMBER, 1965

MODEL NUMBER: C 22

MODIFICATION: Replacement information for circuit modules.

PROCEDURE: C 22's built before 1965 used circuit modules made by Erie Electronics. In 1965 we changed to Sprague Electric Co. The Sprague modules are electrically equivalent to the Erie modules but differ mechanically. The newer Sprague modules are used for replacement when servicing early C 22 units.

The attached schematic shows the lead connections for both the Erie modules (PC 120-161, PC 120-133, PC 120-132, PC 120-134, PC 120-138, and PC 120-160) and the Sprague modules (130-015, 130-016, 130-017, 130-018, 130-019, 130-020, and 130-021.) Follow the schematic to replace an Erie module with a Sprague module.

NOTE: The Sprague 130-015 replaces 2 each PC 120-161 units, and a Sprague 130-018 plus a 130-019 replaces one PC 120-134.

McIntosh

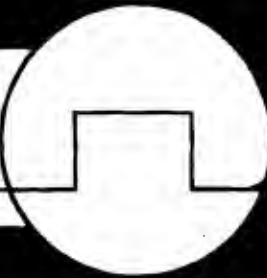

PILOT LAMP REPLACEMENT

To insure long life of festoon pilot lamps, always replace them in pairs in the C22. The two lamps are connected in series. As the lamps age their resistance increases. If only one lamp is replaced the older lamp will have higher resistance than the new lamp. This will cause more voltage to be present across the older lamp. The higher voltage will cause the older lamp to burn out more quickly than it otherwise would.

McIntosh festoon pilot lamps are designated part number 058-011. Specially-selected lamps are available for the C22. When ordering lamps for the C22, please request by part number "058-011 GREEN DOT". Use only the "GREEN DOT" lamp in the C22. Do not use them in any other product.

Al Hyle, Service Manager