

Technical Manual



JBL SR4722

SPECIFICATIONS

ACOUSTIC & ELECTRICAL SPECIFICATIONS:

- Nominal Impedance: 8 ohm
- Power Rating: 600W
- Frequency Response: 53 Hz to 17 kHz
- Sensitivity: 98 dB SPL*
- Crossover Frequencies: 1.2 kHz

SYSTEM COMPONENTS:

- Cabinet: CSR4722
- Grille: GSR4722 (72389)
- Low Frequency Transducer: 305mm (12 in.) Paper Cone Transducer (2206H)
- DC Resistance: 5.3 ohm ± 10% Aluminum Wire

*1 Watt (2.83 V RMS) @ 1 Meter

SYSTEM COMPONENTS: (cont'd)

- High Frequency Transducer: 25mm (1 in.) Pure Titanium Compression Driver (2416H)
- DC Resistance: 3.2 ohm ± 8% Aluminum Wire
- Crossover Network: NSR4722 (72388)

AURAL SWEEP TEST SPECIFICATIONS:

- A. System Aural Sweep Test: 7.0V Input, 20 Hz to 20 kHz
- B. L.F. Aural Sweep Test: 10.0V Input, 20 Hz to 1.2 kHz
- C. M.F. Aural Sweep Test: 2.83V Input, 550 Hz to 1.2 kHz

PHYSICAL SPECIFICATIONS:

- Enclosure Dimensions: 686mm x 492mm x 330mm D (27.0 x 19.37 x 13.0 in. D)
- Shipping Weight: 57.5 lbs. (26 kg)

WARRANTY INFORMATION:

- Refer to the Warranty Statement packed with each product.

PACKAGE

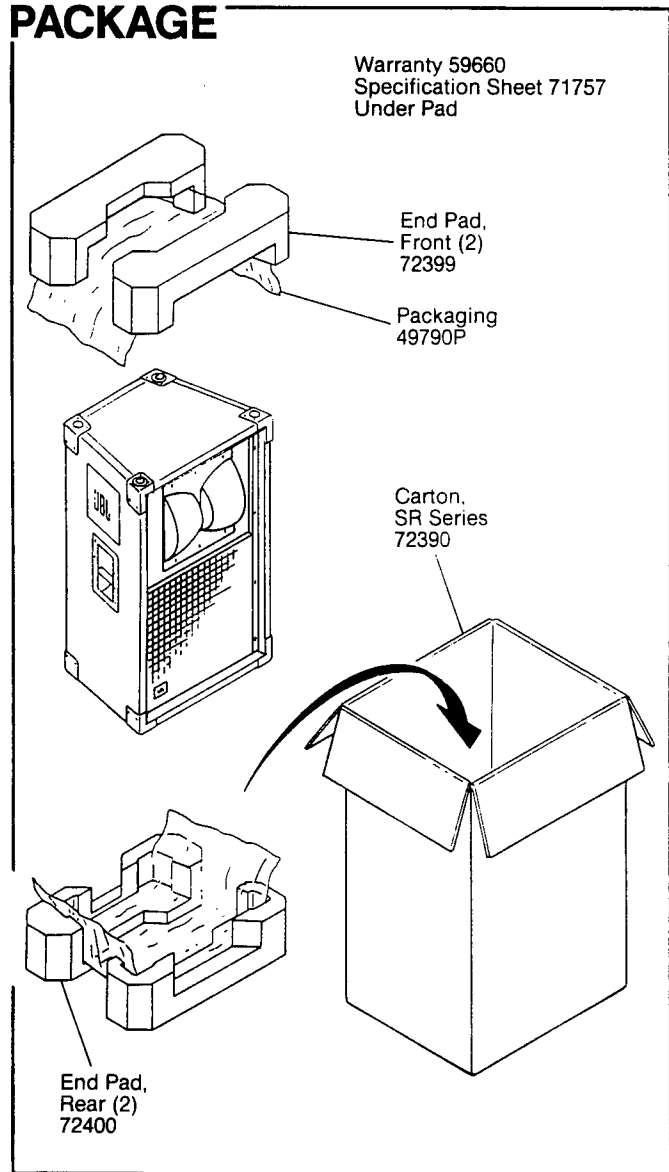

WIRING DIAGRAM

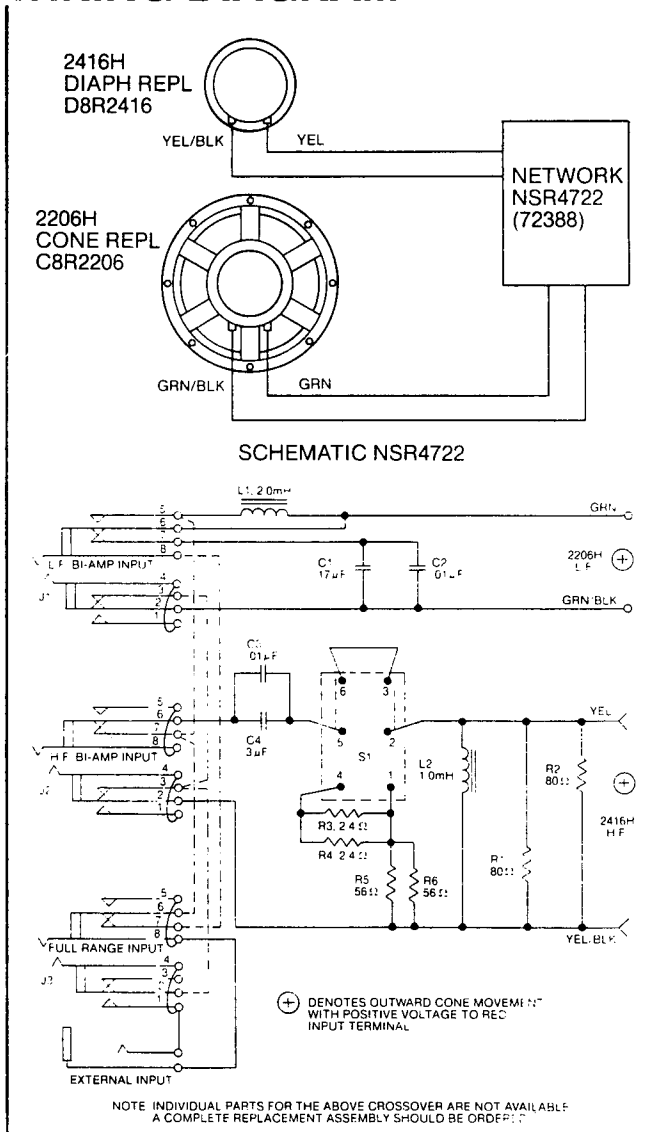

JBL SR4722 REV E

JBL SR4722

COMPONENT EXPLODED VIEW

