



# JBL S1

## SPECIFICATIONS

### ACOUSTIC & ELECTRICAL SPECIFICATIONS:

- Nominal Impedance: 8 ohm
- Power Rating: 10W to 100W
- Frequency Response: 40 Hz to 200 Hz
- Sensitivity: 88 dB SPL\*
- Crossover Frequencies: 125 Hz

### SYSTEM COMPONENTS:

- Cabinet: 70022-01
- Grille: 70023

\*1 Watt (2.83 V RMS) @ 1 Meter

### SYSTEM COMPONENTS: (cont'd)

- Low Frequency Transducer: 203mm (8.0 in.) Dual Voice Coil Polymer Laminate (308 SW)
- Crossover Network: 70173-0060

### PHYSICAL SPECIFICATIONS:

- Enclosure Dimensions: 850mm x 254mm x 254mm D (33.5 x 10.0 x 10.0 in. D)
- Shipping Weight: 38 lbs.

### WARRANTY INFORMATION:

- Refer to the Warranty Statement packed with each product.

## PACKAGE

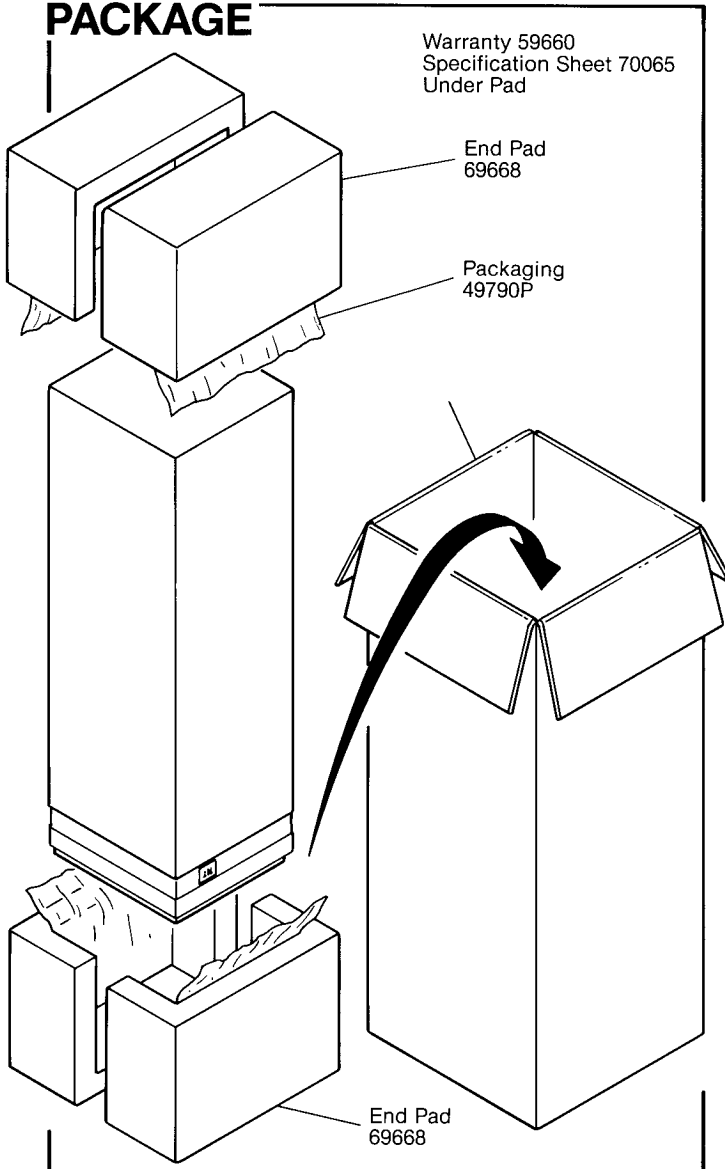

## WIRING DIAGRAM

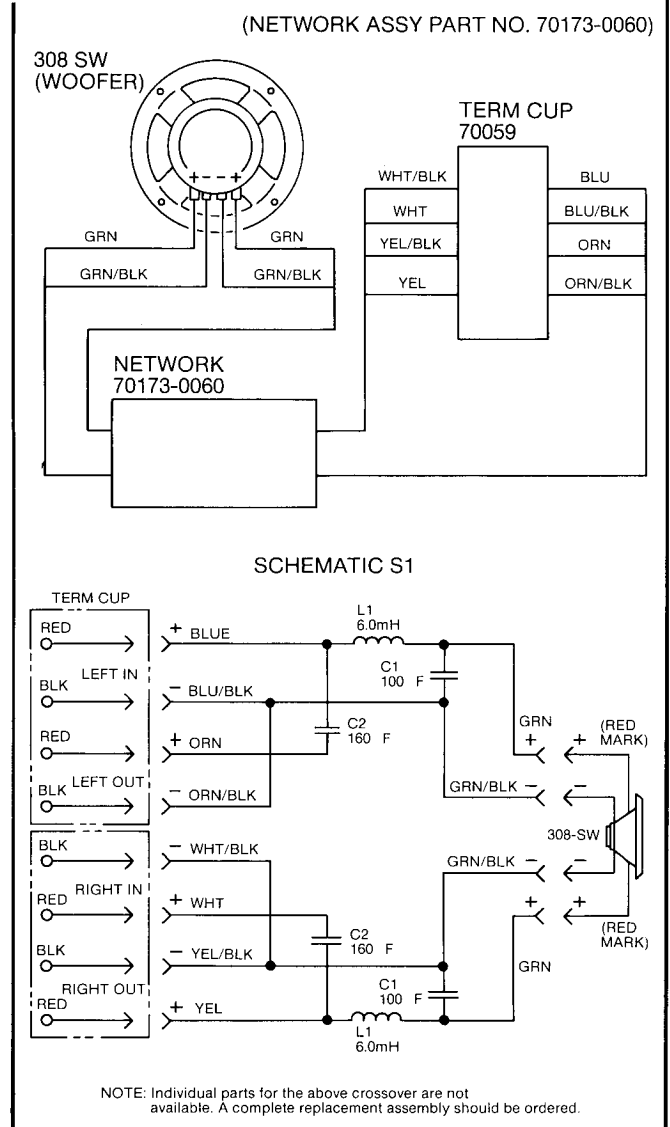

DRIVER	TEST VOLTAGE	SWEEP FREQUENCY	DCR MIN-MAX.
308 SW	4	20HZ-1.0KHZ	4.75-5.25 OHMS

# JBL S1

## COMPONENT EXPLODED VIEW

