

# LX725 MKII



## SPECIFICATIONS

### ACOUSTIC & ELECTRICAL SPECIFICATIONS:

- \* Nominal Impedance: 4 ohm
- \* Recommended Amp Power: 10-150W
- \* Frequency Response: 45 Hz - 25 kHz (-8dB)
- \* Sensitivity: 89 dB / 2,83V / 1 m
- \* Crossover frequency: 300/3000 HZ

### SYSTEM COMPONENTS:

- \* Cabinet: CLX725 MMII (Not for sale)
- \* Grille: GLX725MKII (2401820)
- \* Midrange: A605 130mm Midrange  
Polymer laminate cone
- DC Resistance: 4,0 ohm
- \* Woofer: A606 170mm Woofer  
Polymer laminate cone

### SYSTEM COMPONENTS: (cont'd)

- DC Resistance: 4,0 ohm
- \* Tweeter: A026TS-LX 25mm  
Titanium Dome Tweeter
- \* Crossover Network: NLX725 MKII (2701820)

### PHYSICAL SPECIFICATIONS:

- \* Enclosure Dimensions (H.W.D): 34,3x9,5x10 in. D  
(870x240x255mm D)
- \* Shipping Weight: 38,5 lbs. (17,5 kg.)

### WARRANTY INFORMATION:

- \* Refer to the Warranty Statement packed with each product

## PACKAGE

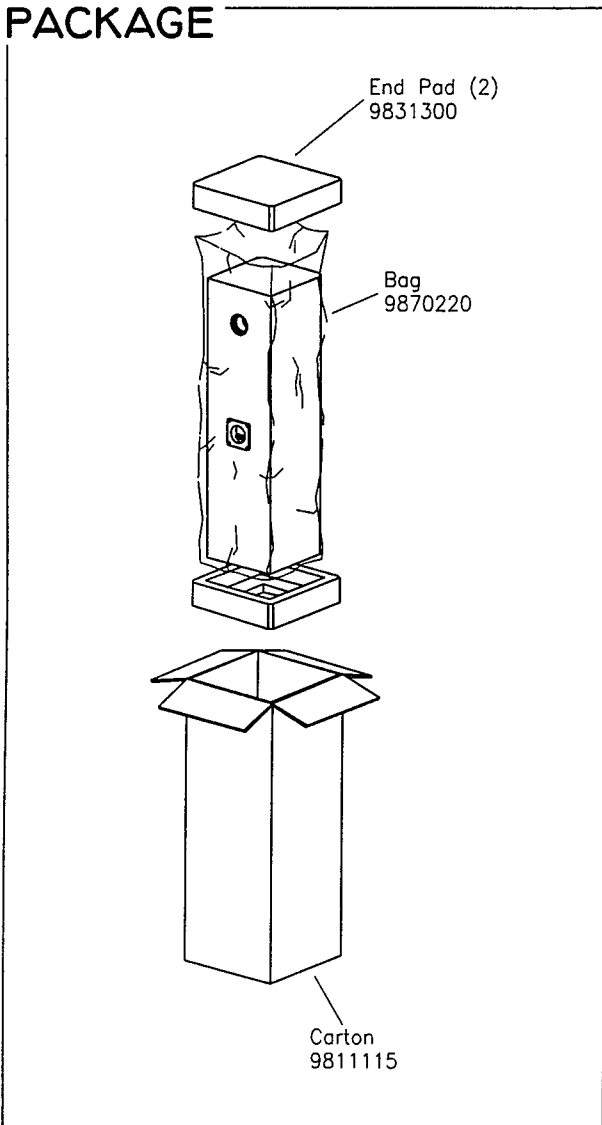

## WIRING DIAGRAM

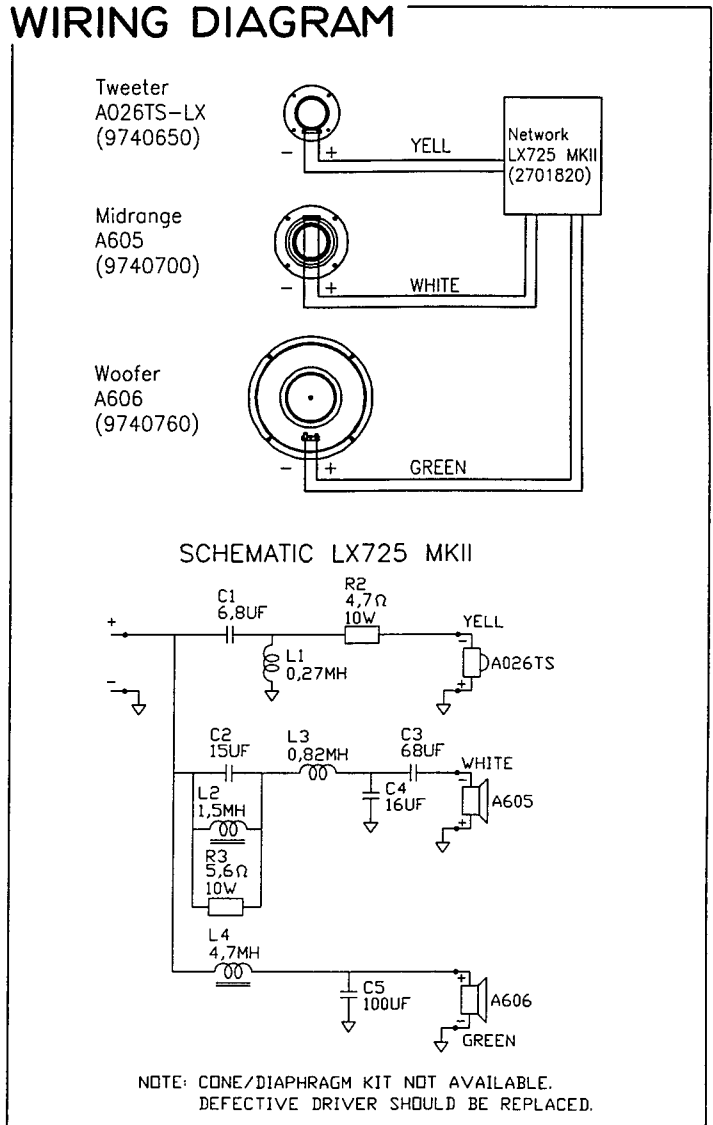

LX725 MKII

Valid from serial no. 01001  
Rev 5/8-1996

# LX725 MKII

## COMPONENT EXPLODED VIEW

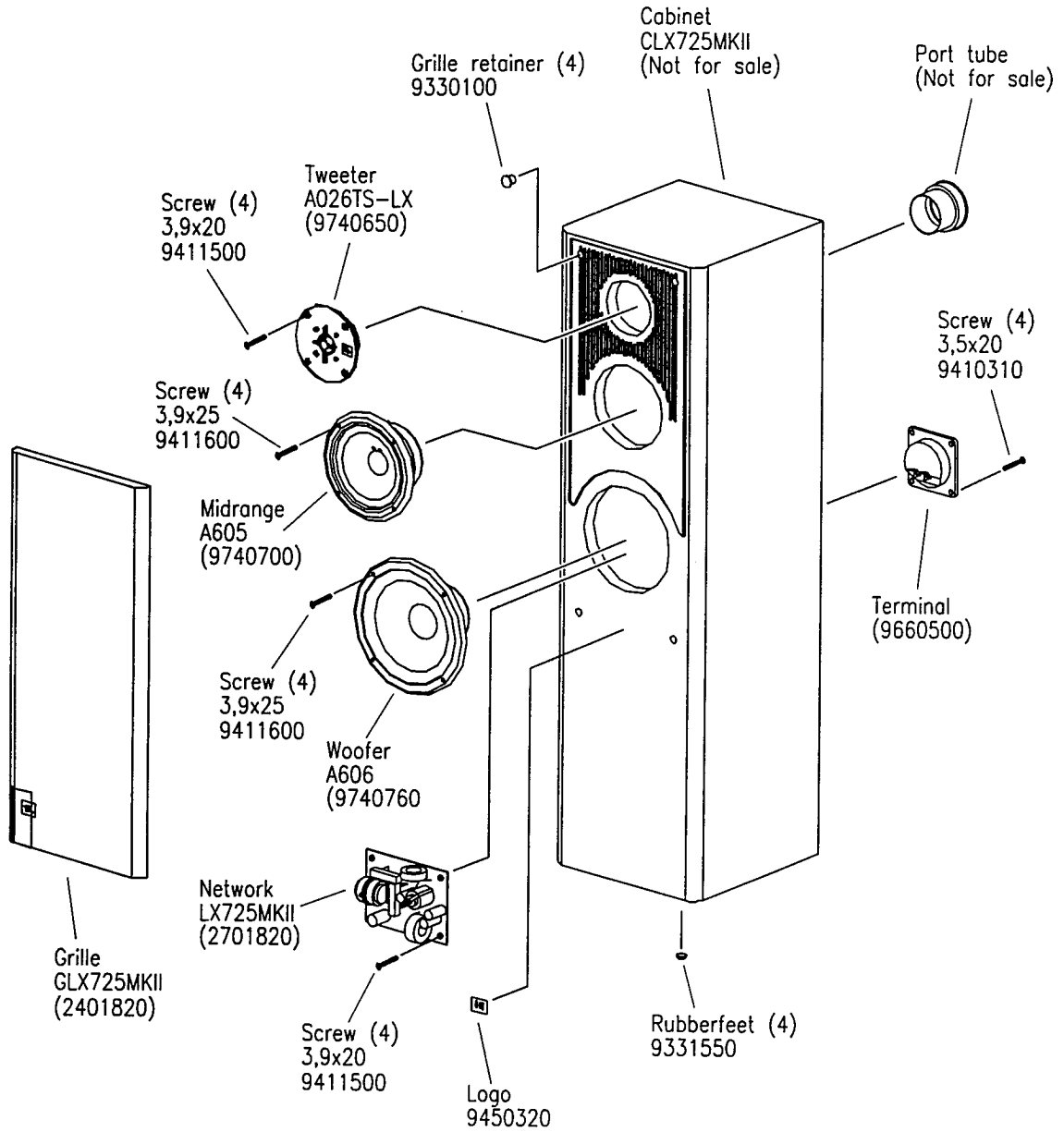

LX725 MKII