

LX50



SPECIFICATIONS

ACOUSTIC & ELECTRICAL SPECIFICATIONS:

- * Nominal Impedance: 6 ohm
- * Recommended Amp Power: 10-200W
- * Frequency Response: 40 Hz - 20 kHz (-6dB)
- * Sensitivity: 88 dB / 2,83V / 1 m
- * Crossover frequency: 600 HZ / 2,5 KHZ

SYSTEM COMPONENTS:

- * Cabinet: CLX50 (Not for sale)
- * Grille: GLX50 (2409370)
- * Woofer: LX250-497 250mm Woofer
38mm voice coil
- DC Resistance: 5,0 ohm
- * Midrange: LX130-97M 130mm Midrange
30mm voice coil

SYSTEM COMPONENTS: (cont'd)

- DC Resistance: 4,6 ohm
- * Tweeter: LX026T-97 25mm
Titanium Dome Tweeter
- DC Resistance: 4,3 ohm
- * Crossover Network: NLX50(2709370)

PHYSICAL SPECIFICATIONS:

- * Enclosure Dimensions (H.W.D): 26x11,8x14,3 In. D
(660x300x363mm D)
- * Shipping Weight: 39,5 lbs. (18 kg.)

WARRANTY INFORMATION:

- * Refer to the Warranty Statement packed with each product

PACKAGE

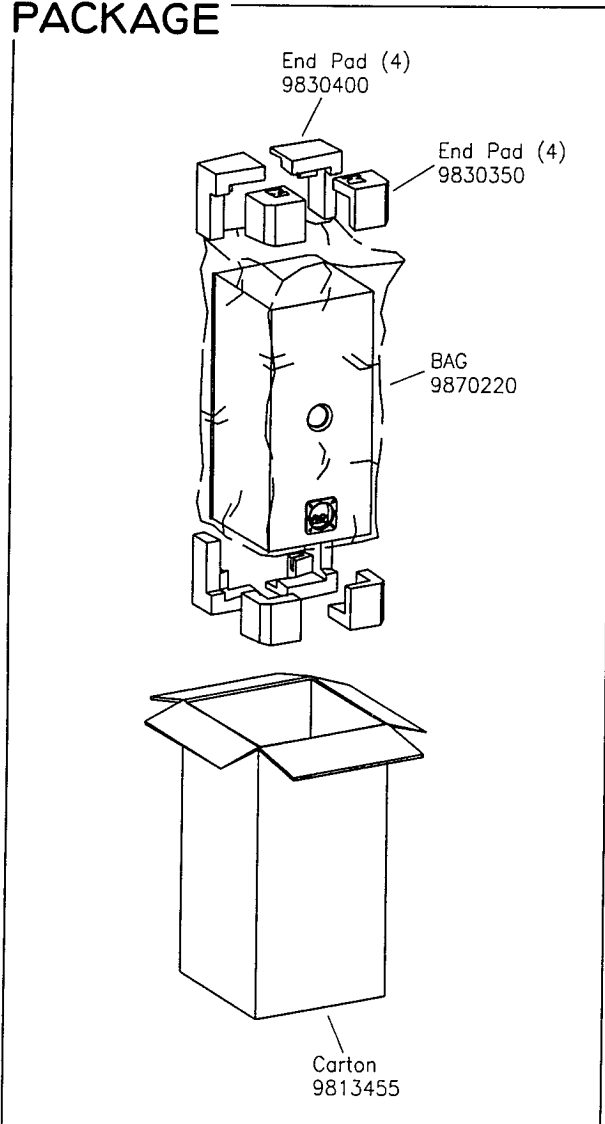

WIRING DIAGRAM

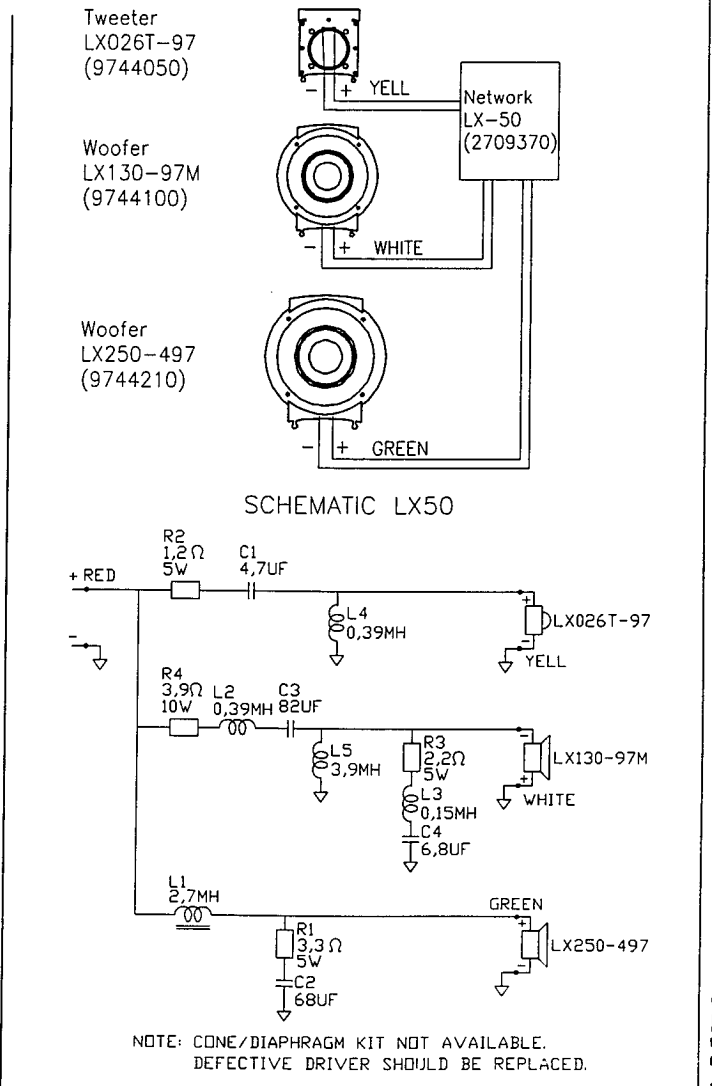

LX50

Valid from serial no. 01001
Rev. 4/2-1998

LX50

COMPONENT EXPLODED VIEW

