

LX20

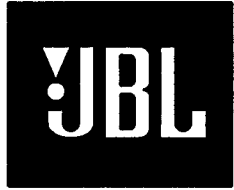

SPECIFICATIONS

ACOUSTIC & ELECTRICAL SPECIFICATIONS:

- * Nominal Impedance: 8 ohm
- * Recommended Amp Power: 10-125W
- * Frequency Response: 50 Hz - 20 kHz (-6dB)
- * Sensitivity: 87 dB / 2,83V / 1 m
- * Crossover frequency: 3 kHz

SYSTEM COMPONENTS:

- * Cabinet: CLX20 (Not for sale)
- * Grille: GLX20 (2409340)
- * Woofer: LX170-4 97 165mm Woofer
30mm voice coil
- DC Resistance: 4,8 ohm

SYSTEM COMPONENTS: (cont'd)

- * Tweeter: LX026T-97 25mm
Titanium Dome Tweeter
- DC Resistance: 4,3 ohm
- * Crossover Network: NLX20 (2709340)

PHYSICAL SPECIFICATIONS:

- * Enclosure Dimensions (H.W.D): 15,8x8,7x11,1 In. D
(400x220x283mm D)
- * Shipping Weight: 35 lbs. (16 kg.)

WARRANTY INFORMATION:

- * Refer to the Warranty Statement packed with each product

PACKAGE

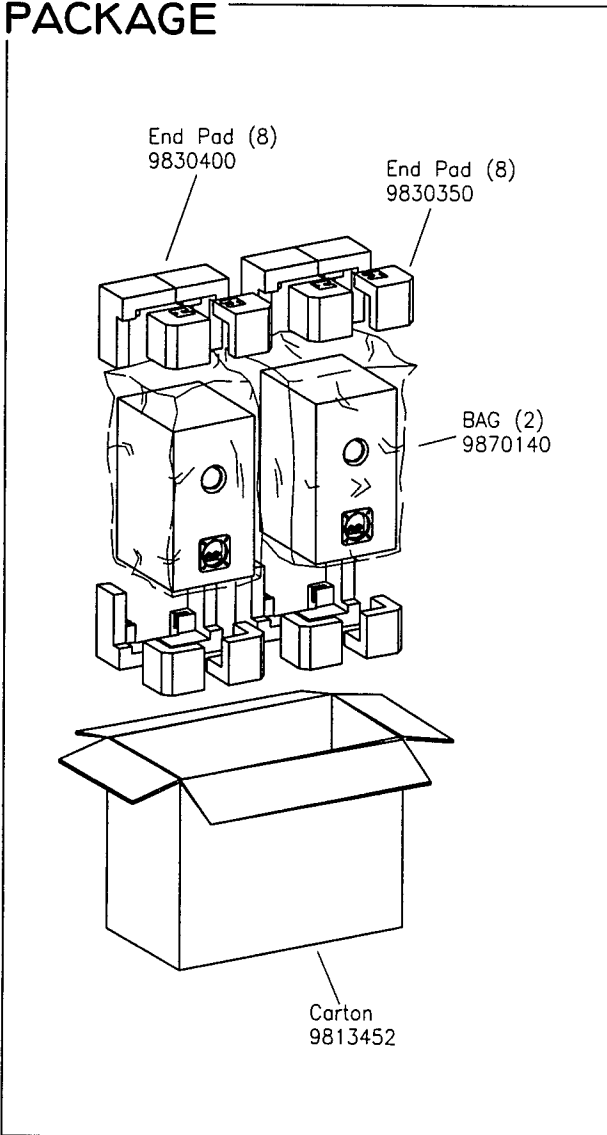

WIRING DIAGRAM

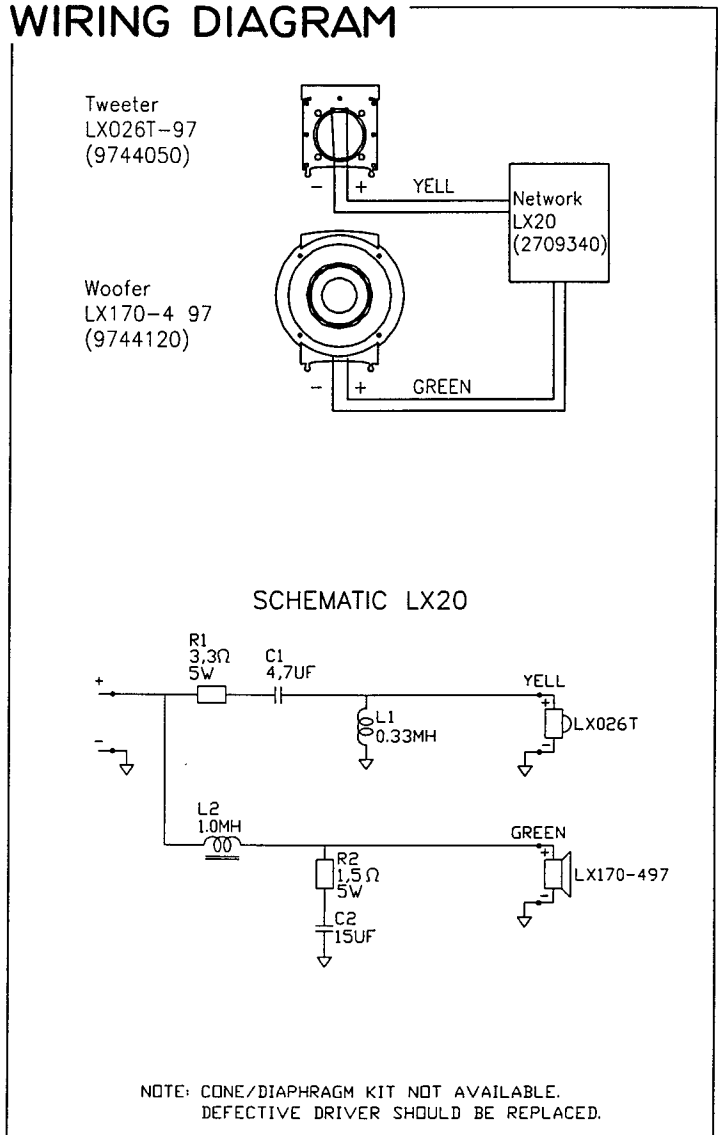

LX20

Valid from serial no. 01001
Rev. 26/10-1997

LX20

COMPONENT EXPLODED VIEW

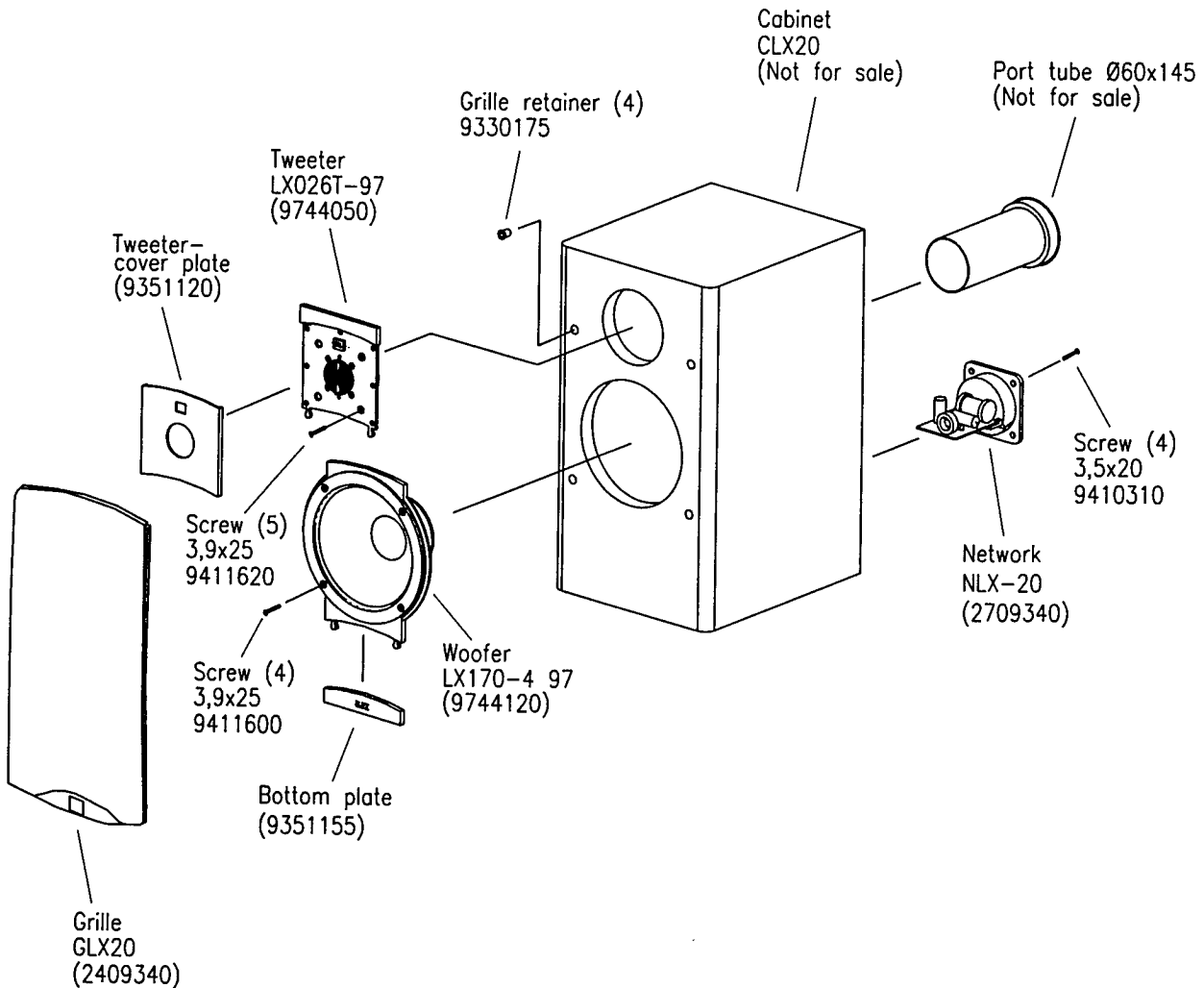

LX20