

L40

SPECIFICATIONS

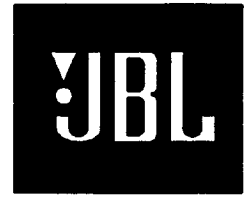

ACOUSTIC & ELECTRICAL SPECIFICATIONS:

- * Nominal Impedance: 4 ohm
- * Recommended Amp Power: 50-200W
- * Frequency Response: 60 Hz - 20 kHz (± 2 dB)
- * Sensitivity: 88 dB / 2,83V / 1 m
- * Crossover frequency: 350HZ / 2,5 kHz

SYSTEM COMPONENTS:

- * Cabinet: CL40 (Not for sale)
- * Grille: GL40 (240735)
- * Woofer: 708G 210mm Woofer
50mm voice coil
- DC Resistance: 4,1 ohm
- * Midrange: 704G 130mm Midrange
25mm voice coil

SYSTEM COMPONENTS: (cont'd)

- DC Resistance: 5,5 ohm
- * Tweeter: 050TI 25mm
Titanium Dome Tweeter
- DC Resistance: 3,8 ohm
- * Crossover Network: NL40 (270736)

PHYSICAL SPECIFICATIONS:

- * Enclosure Dimensions (H.W.D): 25,6x11,8x13 in. D
(650x300x330mm D)
- * Shipping Weight: 48 lbs. (22 kg.)

WARRANTY INFORMATION:

- * Refer to the Warranty Statement packed with each product

PACKAGE

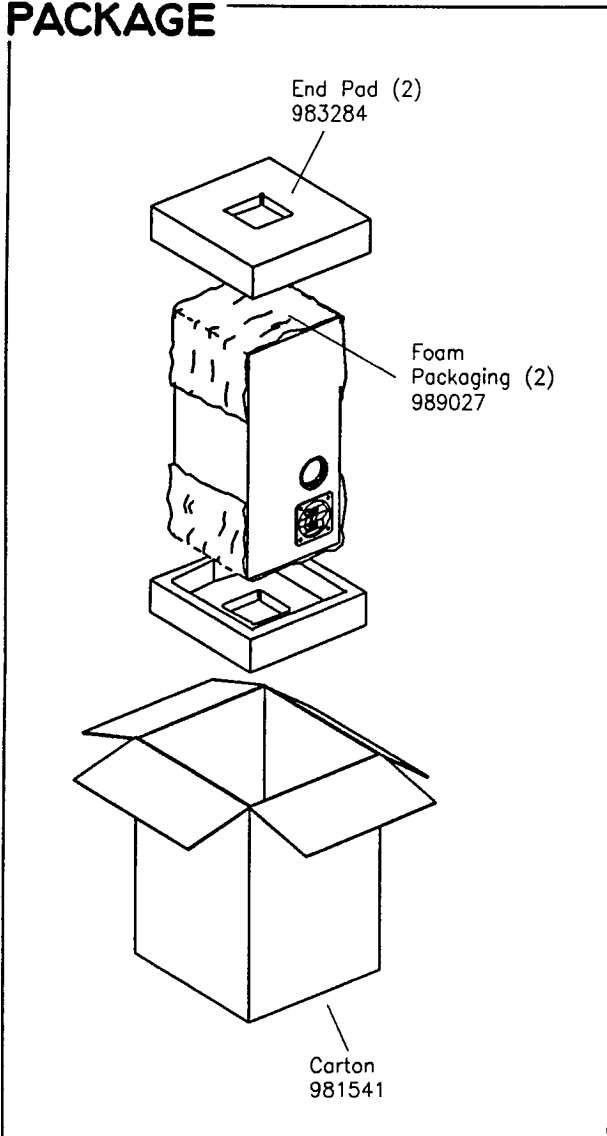

WIRING DIAGRAM

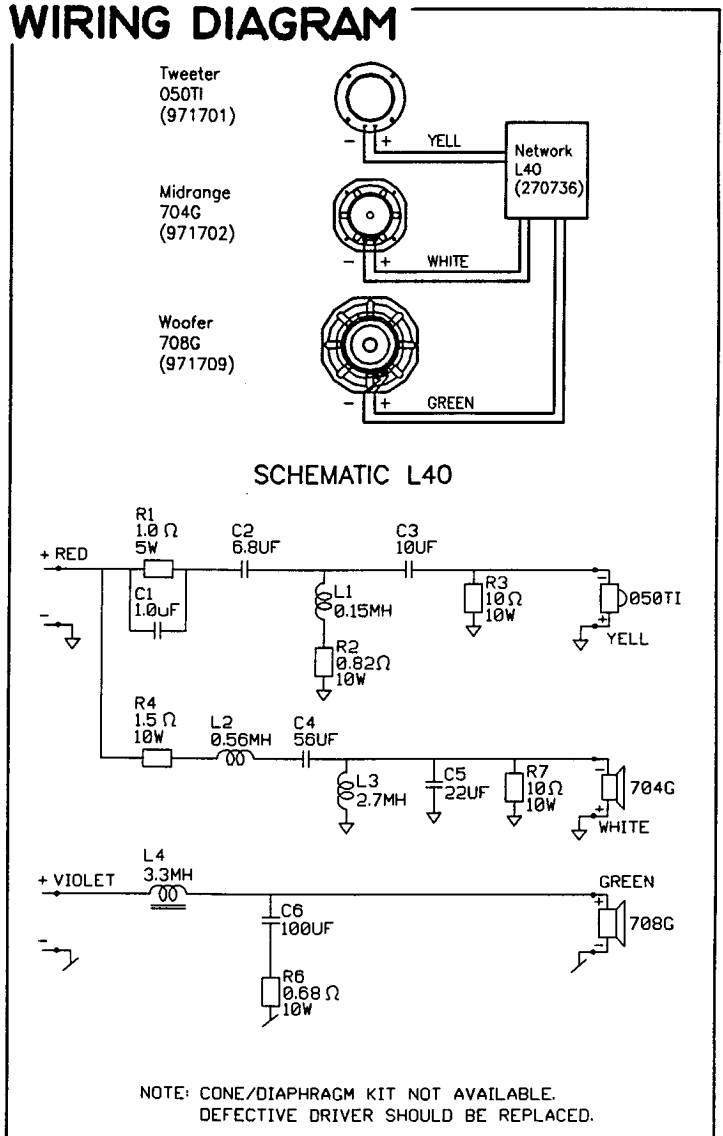

COMPONENT EXPLODED VIEW

