



# HP-8B

## SPECIFICATIONS

### ACOUSTIC & ELECTRICAL SPECIFICATIONS:

- Nominal Impedance: 8 ohm
- Max Amp Power: 200W
- Frequency Range: 46 Hz – 22 kHz (-6 dB)
- Sensitivity: 91 dB SPL, 1 Watt @ 1 Meter.
- Crossover Frequencies: 850 Hz, 3000Hz

### SYSTEM COMPONENTS:

- Cabinet: 330995-001
- Grille: 330241-001
- Low Frequency Transducer: HP8 325757-001  
DC Resistance: 5.8 ohm ±10% Copper Wire
- Mid Range Transducer: HP5 325781-001  
DC Resistance: 4.6 ohm ±10% Copper Wire
- High Frequency Transducer: HP027Ti 325792-001  
DC Resistance: 3.6 ohm ±10% Copper Wire

### SYSTEM COMPONENTS: (cont'd)

- Crossover Network: 330999-002

### AURAL SWEEP TEST SPECIFICATIONS:

- A. System Aural Sweep Test: 6.0V Input, 20 Hz to 20 kHz
- B. L.F. Aural Sweep Test: 6.0V Input, 20 Hz to 2.7 kHz
- C. M.F. Aural Sweep Test: 6.0V Input, 700 Hz to 5 kHz
- D. H.F. Aural Sweep Test: 2.83V Input, 2kHz to 20 kHz

### PHYSICAL SPECIFICATIONS:

- Enclosure Dimensions: 23.12 x 11.5 x 10.0 in.D  
(584mm x 292mm x 254mm D)

### SHIPPING WEIGHT:

36.5 lbs. (16.6 kg.)

### WARRANTY INFORMATION:

- Refer to Warranty Statement packed with each product.

## PACKAGE

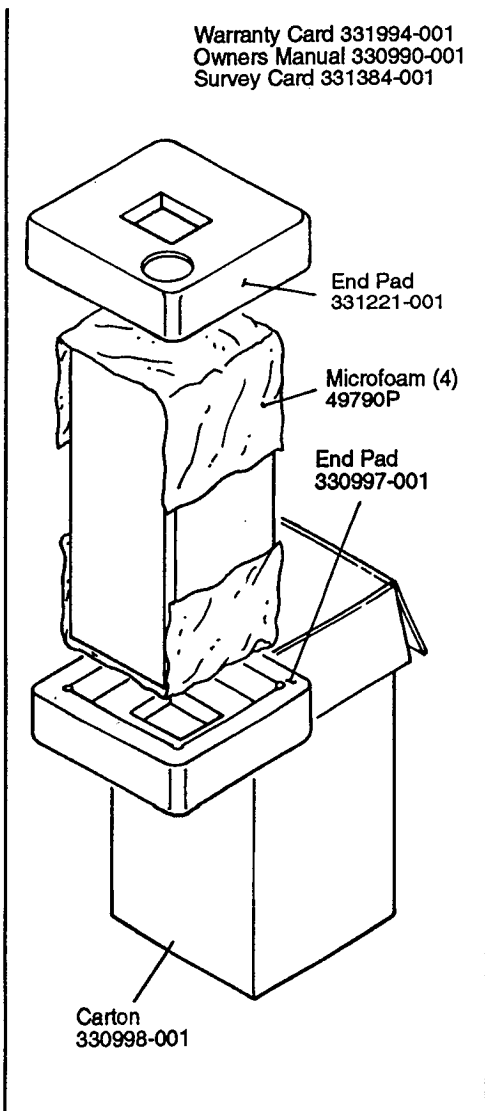

## WIRING DIAGRAM

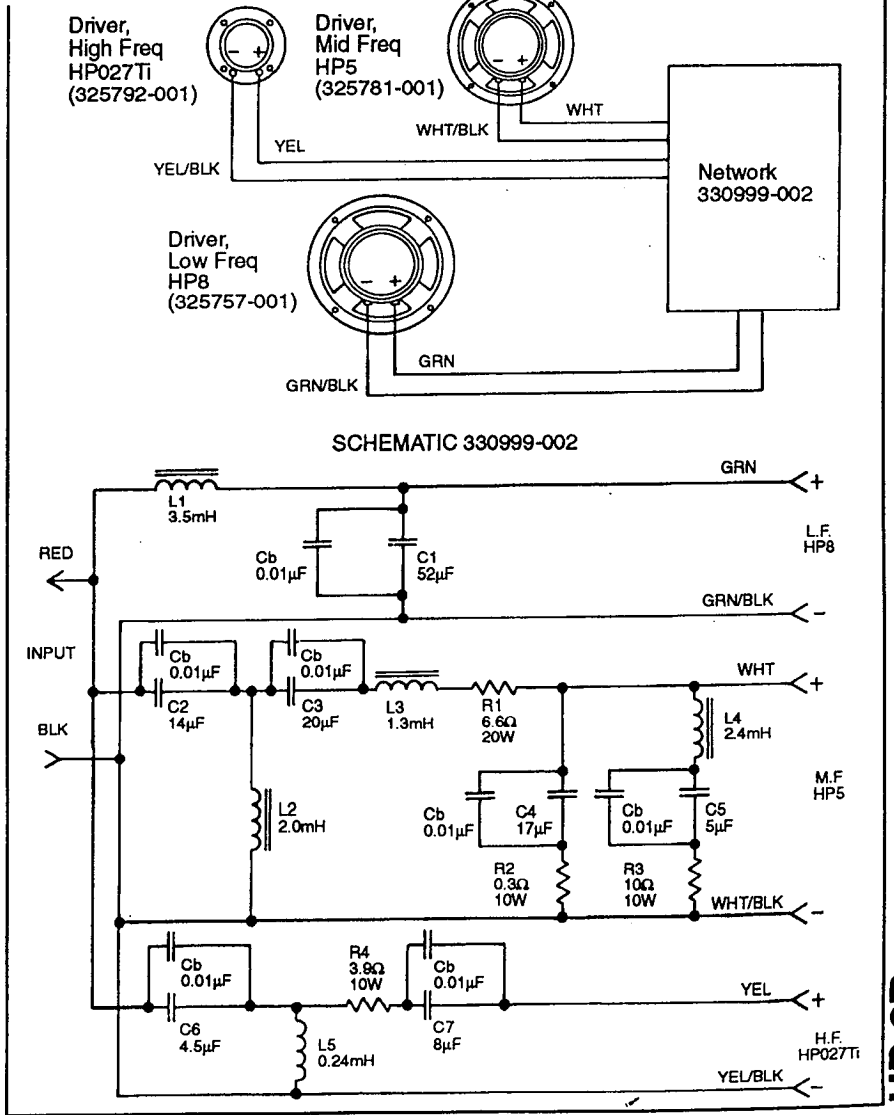

### SCHEMATIC 330999-002

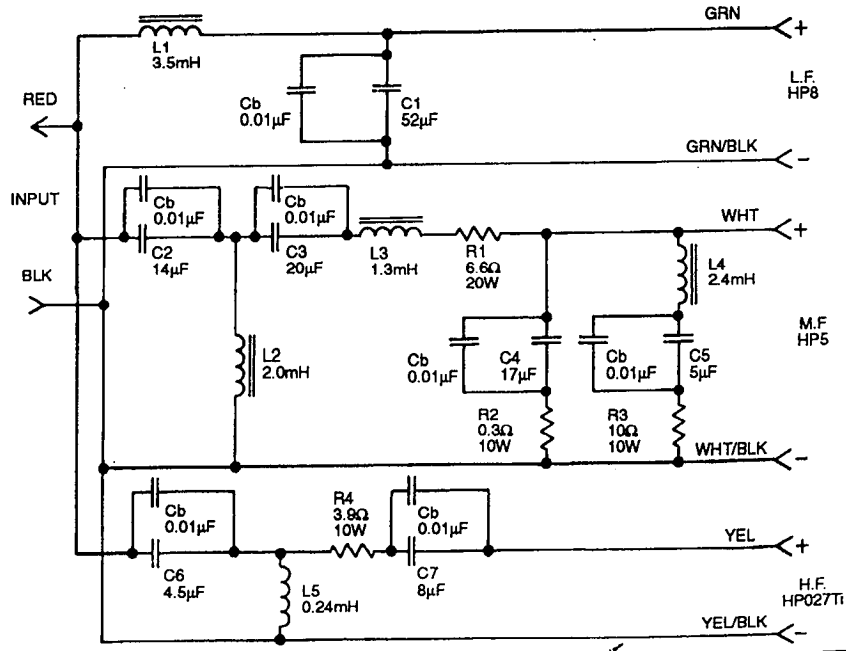

HP-8B

# HP-8B

## COMPONENT EXPLODED VIEW

