

Technical Manual



JBL8305P2

SPECIFICATIONS

ACOUSTIC & ELECTRICAL SPECIFICATIONS:

- Nominal Impedance: 8 ohm
- Power Rating: Continuous Pink Noise: 40W
- Frequency Response: 90 Hz to 19 kHz
- Sensitivity: 89 dB SPL*
- Crossover Frequencies: 7.0 kHz

SYSTEM COMPONENTS:

- Cabinet: N/A
- Grille: G8305P2 (70196)
- Low Frequency Transducer: 134mm (5.25 in.) High Polymer Laminate (305G-3A)
- DC Resistance: 4.0 ohm $\pm 5\%$ — Copper Wire

*1 Watt (2.83 V RMS) @ 1 Meter

SYSTEM COMPONENTS: (cont'd)

- High Frequency Transducer: 25mm (1 in.) Pure Titanium Dome (029Ti)
- DC Resistance: 3.5 to 4.2 ohm — Copper Wire
- Crossover Network: N8305P2, 2 Way System (70547)

AURAL SWEEP TEST SPECIFICATIONS:

- A. System Aural Sweep Test: 6.0V Input, 50 Hz to 20 kHz
- B. L.F. Aural Sweep Test: 4.0V Input, 50 Hz to 1.2 kHz
- C. H.F. Aural Sweep Test: 2.0V Input, 2.0 kHz to 20 kHz

PHYSICAL SPECIFICATIONS:

- Enclosure Dimensions: N/A
- Shipping Weight: 10 lbs./Pair (4.5 kg)

WARRANTY INFORMATION:

- Refer to the Warranty Statement packed with each product.

PACKAGE

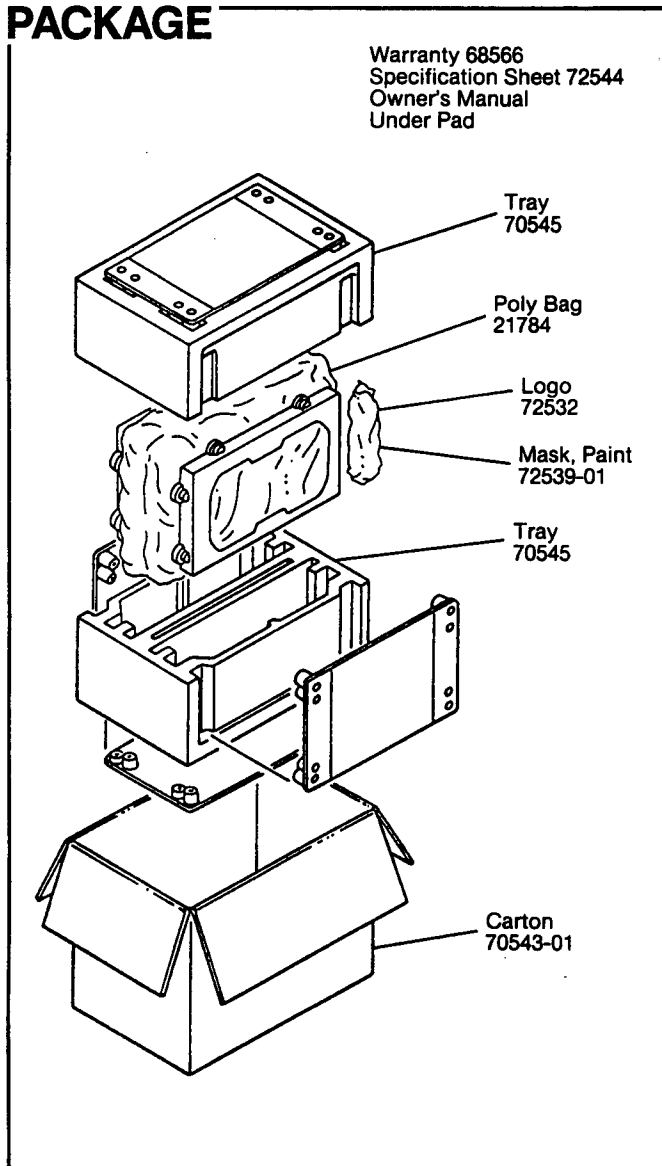

WIRING DIAGRAM

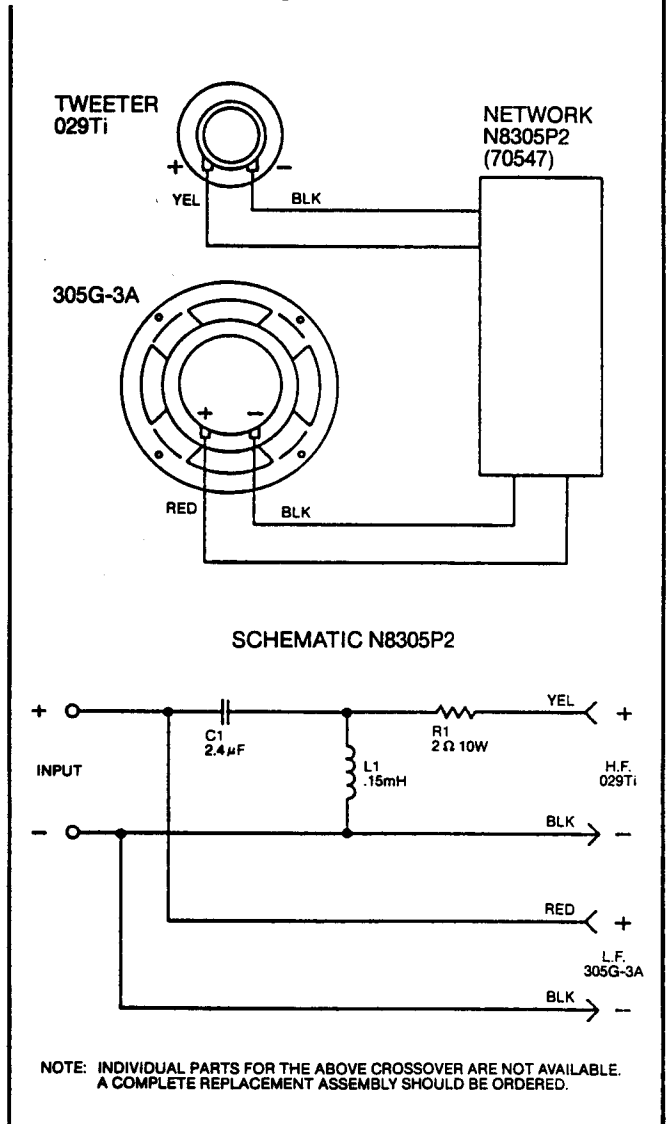

JBL8305P2 REV B

JBL8305P2

COMPONENT EXPLODED VIEW

