

The Harman Kardon Model PM665

Manual 86A

STEREO INTEGRATED AMPLIFIER

Technical Manual

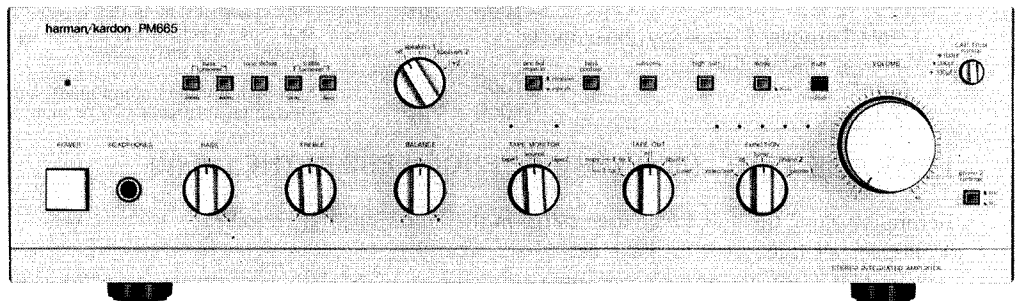

harman/kardon

240 Crossways Park West, Woodbury, N.Y. 11797
1112-H15286A0 P-088503 1850 Printed in Japan

SPECIFICATIONS

	Nominal	Limit
RMS Output Power		
8Ω, 20Hz ~ 20kHz, THD 0.08%	110W	≥ 100W
4Ω, 1kHz, THD 1.0%	187W	≥ 180W
High Instantaneous Current Capability (HCC)	74A	≥ 60A
Harf Power Bandwidth	10Hz	~ 100kHz
Frequency Response at -3dB	0.18Hz	~ 177kHz
Input Sensitivity		
Video/CD	135mV	± 25mV
Phono (MM)	2.2mV	± 0.2mV*
Phono (MC)	120μV	± 20μV*
Signal to Noise Ratio		
Video/CD	78.4dB	≥ 76dB
Phono (MM)	77.5dB	≥ 75dB
Phono (MC)	76dB	≥ 74dB
Channel Separation at 10kHz		
Video/CD	53.7dB	≥ 45dB
Phono (MM)	56dB	≥ 45dB
Phono (MC)	51dB	≥ 44dB
IM Distortion Ratio	0.06%	≤ 0.1%
Damping Factor at 1kHz	88	≥ 60
Tone Control Characteristics		
Bass Turnover Frequency (200Hz/400Hz)		
Bass at 50Hz/100Hz		
Boost	10dB	± 2dB
Cut	-10dB	± 2dB
Treble Turnover Frequency (2kHz/6kHz)		
Treble at 10kHz/30kHz		
Boost	10dB	± 2dB
Cut	-10dB	± 2dB

	Nominal	Limit
Filters		
Subsonic	15Hz,	6dB/Octave
High Cut	6kHz,	6dB/Octave
Bass Contour		
Boost at 50Hz	+10dB	
DC Output Voltage		
L channel	0mV	± 60mV
R channel	0mV	± 60mV
RIAA Equalization at Tape Out (20Hz/20kHz) (No load)	0.1dB	± 0.5dB/0.1dB ± 0.5dB
Phono Overload (No load)		
Phono (MM)	198mV	≥ 180mV
Phono (MC)	10.9mV	≥ 8mV
Dimensions (W x H x D)	17-1/2" x 5-5/16" x 15-11/16"	(443 x 134 x 398 mm)
Weight	29 lbs.	12 oz. (13.5 kg)
Power Supplies		
U.S.A. and Canada models	AC 120V,	60Hz
General and German models	AC 220/240V,	50/60Hz
Power Consumption		
U.S.A. and Canada models	550W	(600VA)
General and German models	485W	

*Input Sensitivity for German model are 2.4mV ± 0.2mV (MM) and 145μV ± 20μV (MC).

This specification is the target of servicing. But, there is a case that the specification is not applicable to the measurement condition and instrument.

Specifications and components subject to change without notice. Overall performance will be maintained or improved.

LEAKAGE TEST (FOR SERVICE ENGINEERS IN THE U.S.A.)

Before returning the unit to the user, perform the following safety checks:

1. Inspect all lead dress to make certain that leads are not pinched or that hardware is not lodged between the chassis and other metal parts in the unit.
2. Be sure that any protective devices such as nonmetallic control knobs, insulating fishpapers, cabinet backs, adjustment and compartment covers or shields, isolation resistor-capacity networks, mechanical insulators, etc. which were removed for servicing are properly reinstalled.
3. Be sure that no shock hazard exists; check for leakage current using Simpson Model 229 Leakage Tester, standard equipment item No. 21641, RCA Model WT540A or use alternate method as follows:
 Plug the power cord directly into a 120-volt AC receptacle (do not use an Isolation Transformer for this test). Using two clip leads, connect a 1500 Ohm, 10-watt resistor paralleled by a 0.15μF capacitor, in series with all exposed metal cabinet parts and a known earth ground, such as a water pipe or conduit. Use a VTVM or VOM with 1000 Ohms per volt, or higher, sensitivity to measure the AC voltage drop across the resistor. (See Diagram.) Move the resistor connection to each exposed metal part having a return path to the chassis (antenna, metal, cabinet, screw heads, knobs and control shafts, escutcheon, etc.) and measure the AC voltage drop across the resistor. (This test should be performed with the power switch in both the On and Off positions.)

A reading of 0.35 volt RMS or more is excessive and indicates a potential shock hazard which must be corrected before returning the unit to the owner.

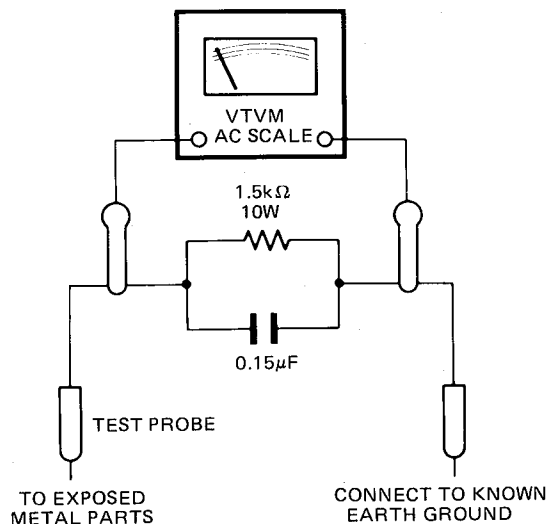
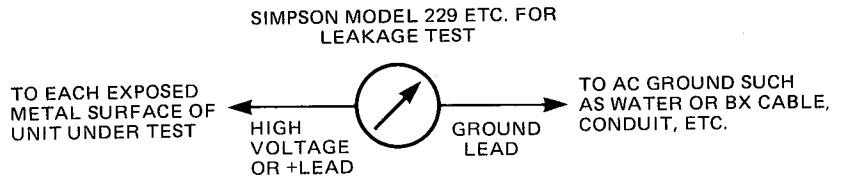

ALIGNMENT PROCEDURES (REFER TO PAGES 12 AND 13)

- **Conditions:**
 - Set the Function selector to the "video/aux" position.
 - Set the Volume control to minimum.
 - Set the Speaker selector to "off" position.
 - Make the adjustment at a room temperature of 77°F (25°C).
 - After the Power switch is pushed on, wait for 30 minutes before measuring to be sure of the most stable operation.

■ DC BALANCE ADJUSTMENT

Step	Connection Equipments	Adjustment	For
1	Connect the Digital Volt Meter to TP1 and TP2.	VR401	0 ± 10mV
2	Connect the Digital Volt Meter to TP3 and TP2.	VR402	0 ± 10mV

■ IDLING CURRENT ADJUSTMENT

Step	Connection Equipments	Adjustment	For
1	Connect the Digital Volt Meter to TP4 and TP5.	VR403	50mV
2	Connect the Digital Volt Meter to TP6 and TP7.	VR404	50mV

■ IDLING CURRENT CONFIRMATION

Step	Connection Equipments	For
1	Connect the Digital Volt Meter to TP8 and TP9.	50mV ± 5mV
2	Connect the Digital Volt Meter to TP10 and TP11.	50mV ± 5mV
3	Connect the Digital Volt Meter to TP12 and TP13.	50mV ± 5mV
4	Connect the Digital Volt Meter to TP14 and TP15.	50mV ± 5mV

BLOCK DIAGRAM

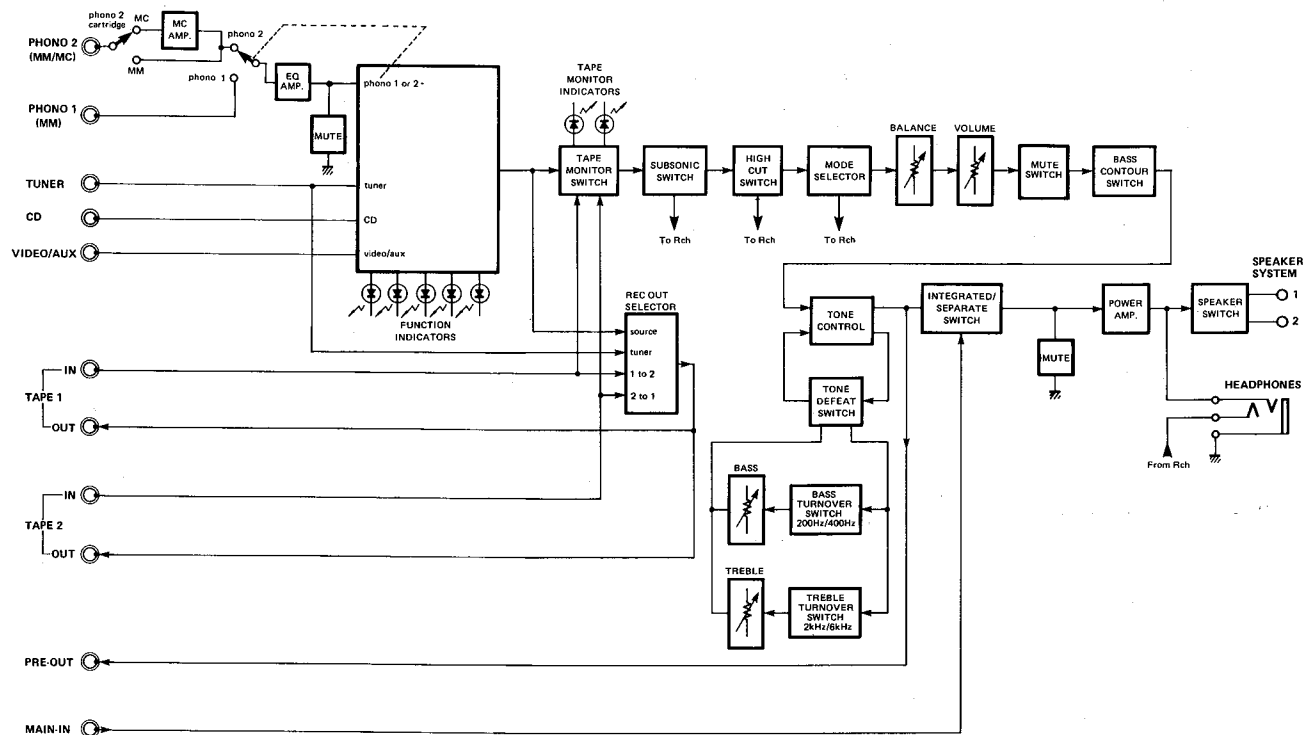

DISASSEMBLY PROCEDURES (REFER TO PAGES 5, 6 AND 13)

1 CABINET TOP (132) REMOVAL

Remove 8 screws (A) and remove the Cabinet Top (132).

2 FRONT PANEL ASSEMBLY (101) REMOVAL

1. Remove the Cabinet Top (132). (Refer to step 1.)
2. Remove 5 screws (B) and remove the Front Panel Assembly (101).

3 MAIN P.C. BOARD (PCB-1) REMOVAL

1. Remove 10 screws (C) and remove the Cabinet Bottom (133).
2. Remove the Front Panel Assembly (101). (Refer to step 2.)
3. Loosen 4 hexagon-socket-head screws (D) and pull out the Shaft (196) with the Speaker Selector Knob Assembly (102).
4. Remove 24 screws (E) and snap-in-fastener (F), then remove the Cabinet Back (134). If necessary, unsolder the lead wires from the Power Transformer (T1 and T2).
5. Open the lid of connectors (CN101 and CN102) on the Main P.C. Board (PCB-1) and then disconnect the lead wires.
6. Remove 4 screws (G) and remove the Main P.C. Board (PCB-1) with Heat Sinks (179). At this time, unsolder the lead wires connected to the Main P.C. Board (PCB-1).

4 POWER SWITCH P.C. BOARD (PCB-6) REMOVAL

1. Remove the Front Panel Assembly (101). (Refer to step 2.)
2. Pull out the Power Push Button Assembly (105) and Shaft (192).
3. Remove 3 screws (H) and remove the Power Switch P.C. Board (PCB-6). If necessary, unsolder the lead wires.

5 DRIVER P.C. BOARD (PCB-3) REMOVAL

1. Remove the Main P.C. Board (PCB-1). (Refer to step 3.)
2. Remove 2 screws (I) and remove the Driver P.C. Board (PCB-3). If necessary, unsolder the lead wires.

6 EQUALIZER P.C. BOARD (PCB-2) REMOVAL

1. Remove the Cabinet Back (134). (Refer to step 3 -1 through 4.)
2. Remove screw (J) and snap-in-fastener (K), then remove the Equalizer P.C. Board (PCB-2). If necessary, unsolder the lead wires.

7 TONE CONTROL P.C. BOARD (PCB-4) REMOVAL

1. Remove the Cabinet Bottom (133). (Refer to step 3 -1.)
2. Pull out the Cap. Trim Knob (148) and remove hexagon nut (L), then remove the Capacitance Trim P.C. Board (PCB-9).
3. Pull out the Volume Knob Assembly (103) and remove hexagon nut (M), then remove the Volume Control P.C. Board (PCB-8).
4. Remove 2 screws (N) and remove the Push Switch (SW701A, Phono 2 Cartridge).
5. Straighten the catches fixing the Power Indicator P.C. Board (PCB-10) and remove the Power Indicator P.C. Board (PCB-10).
6. Remove the metal fixture (O) fixing the Headphones P.C. Board (PCB-12) and remove the Headphones P.C. Board (PCB-12).
7. Pull out the Power Push Button Assembly (105) and Shaft (192).
8. Pull out the 6 Knob Assemblies (102).
9. Loosen 4 hexagon-socket-head screws (D) and pull out the Shaft (196) with the Speaker Selector Knob Assembly (102).
10. Remove 8 screws (P) and remove the Chassis Assembly (106) with the Tone Control and Push Switches P.C. Boards (PCB-4 and PCB-5).
11. Remove 4 screws (Q) and remove the Push Switches P.C. Board (PCB-5). If necessary, unsolder the lead wires.
12. Remove 6 hexagon nuts (R) and remove the Tone Control P.C. Board (PCB-4). If necessary, unsolder the lead wires.

POWER CORD REPLACEMENT (FOR SERVICE ENGINEERS OTHER THAN NORTH AMERICA)

In order to prevent fire or shock hazard when replacing the power cord, follow the procedure below to replace the parts with the standard supply parts.

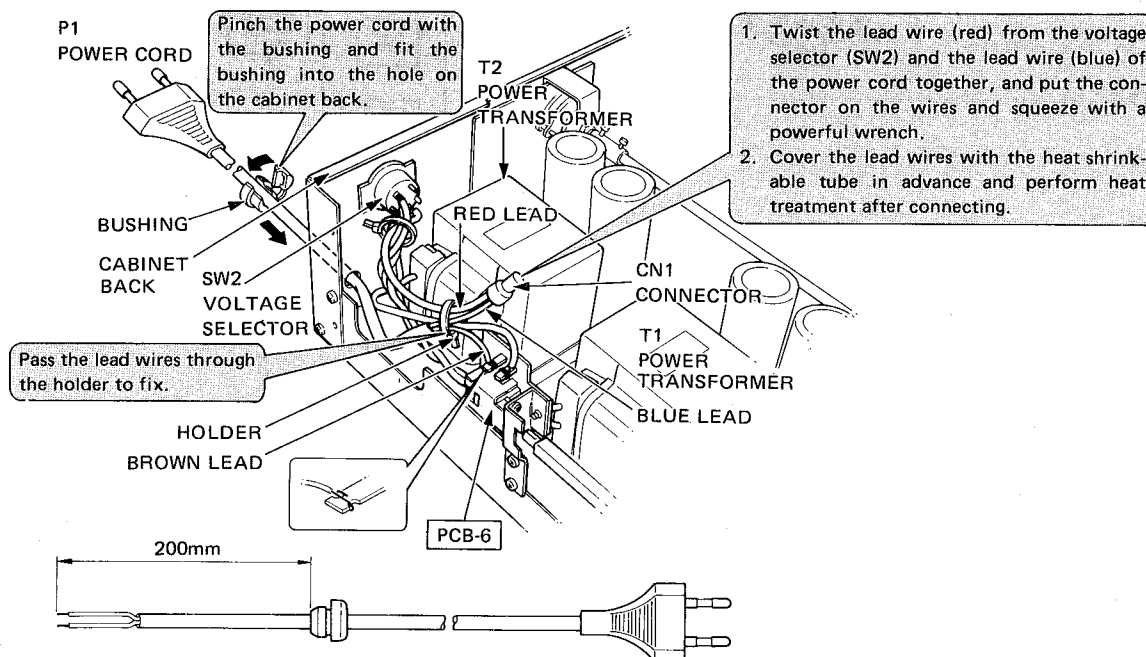

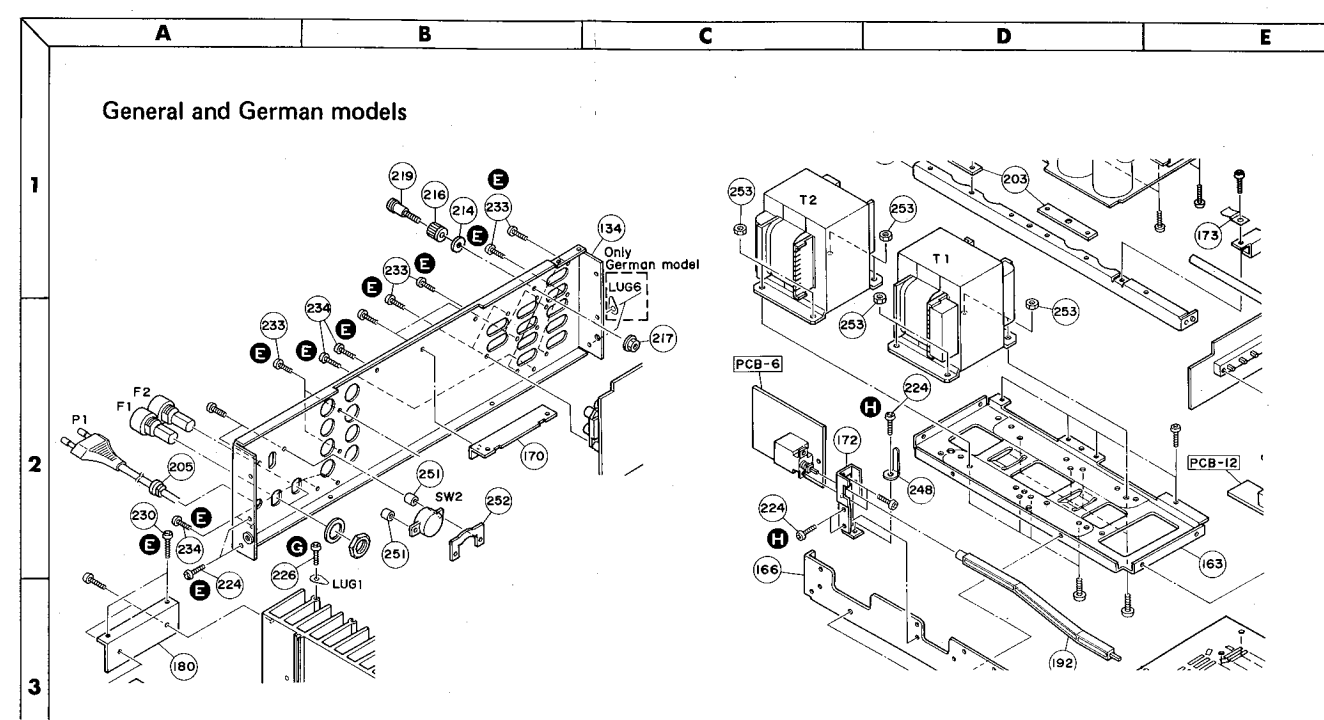
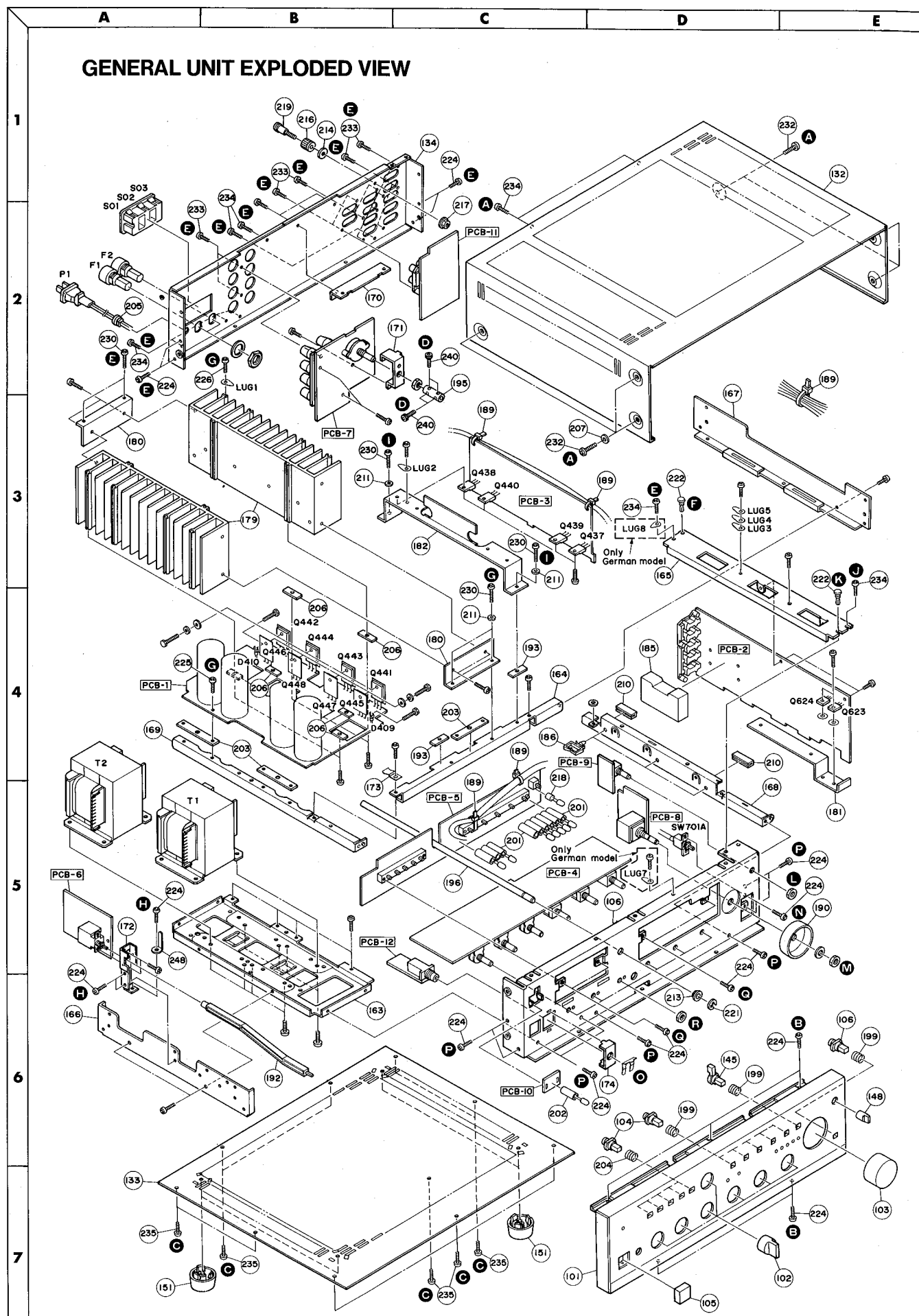

GENERAL UNIT PARTS LIST

Ref. No.	Part No.	Description
101	A443-PM665A	Front Panel Assembly
102	A630-PM665A	Knob Assembly, Bass, Treble, Balance, Tape Monitor, Tape Out, Function, Speaker System Selector
103	A630-PM665B	Knob Assembly, Volume
104	A662-PM665A	Push Button Assembly, Bass Turnover, Tone Defeat, Treble Turnover, Pre-out Main-in, Bass Contour, Subsonic, High Cut, Mode, Cartridge
105	A660-PM665A	Push Button Assembly, Power
106	B211-PM665A	Chassis Assembly
132	1414-05501	Cabinet Top
133	1423-02201	Cabinet Bottom
134	1424-14801	Cabinet Back (for U.S.A. and Canada models)
"	1424-14901	Cabinet Back (for General and German models)
145	1662-18101	Push Button, Mute
148	1634-04501	Knob, Cap. Trim
151	1319-0139	Foot
163	2219-8036	Bracket
164	2219-8037	Bracket
165	2219-8009	Bracket
166	2219-8010	Bracket
167	2219-8011	Bracket
168	2219-8038	Bracket
169	2219-8013	Bracket
170	2219-8040	Bracket
171	2219-8039	Bracket
172	2219-8034	Bracket
173	2219-8044	Bracket
174	2219-7879	Bracket
179	2222-7180	Heat Sink (for U.S.A. and Canada models)
"	2222-7187	Heat Sink (for General and German models)
180	2222-7182	Heat Sink
181	2222-7183	Heat Sink
182	2222-7181	Heat Sink

GENERAL UNIT EXPLODED VIEW

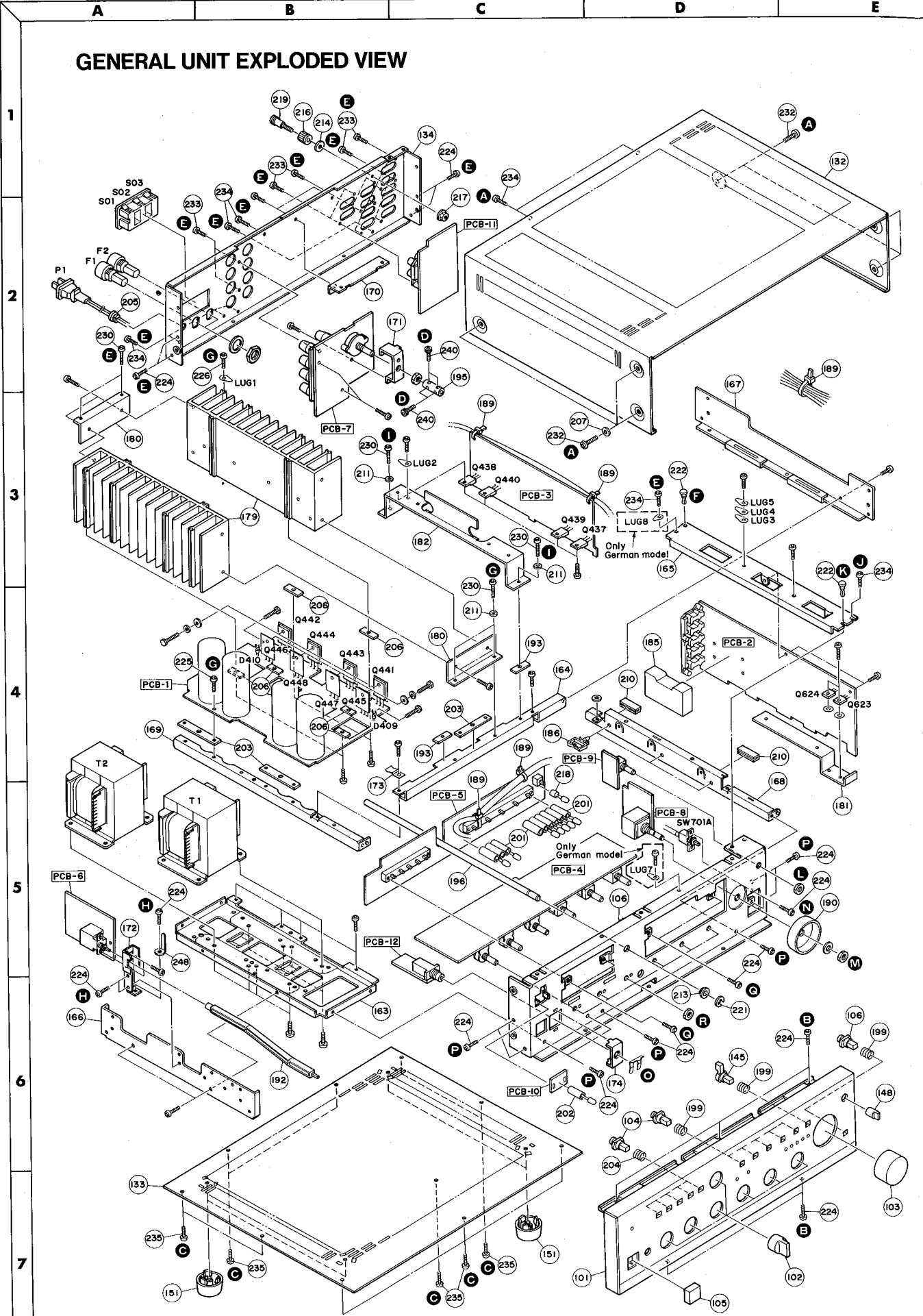

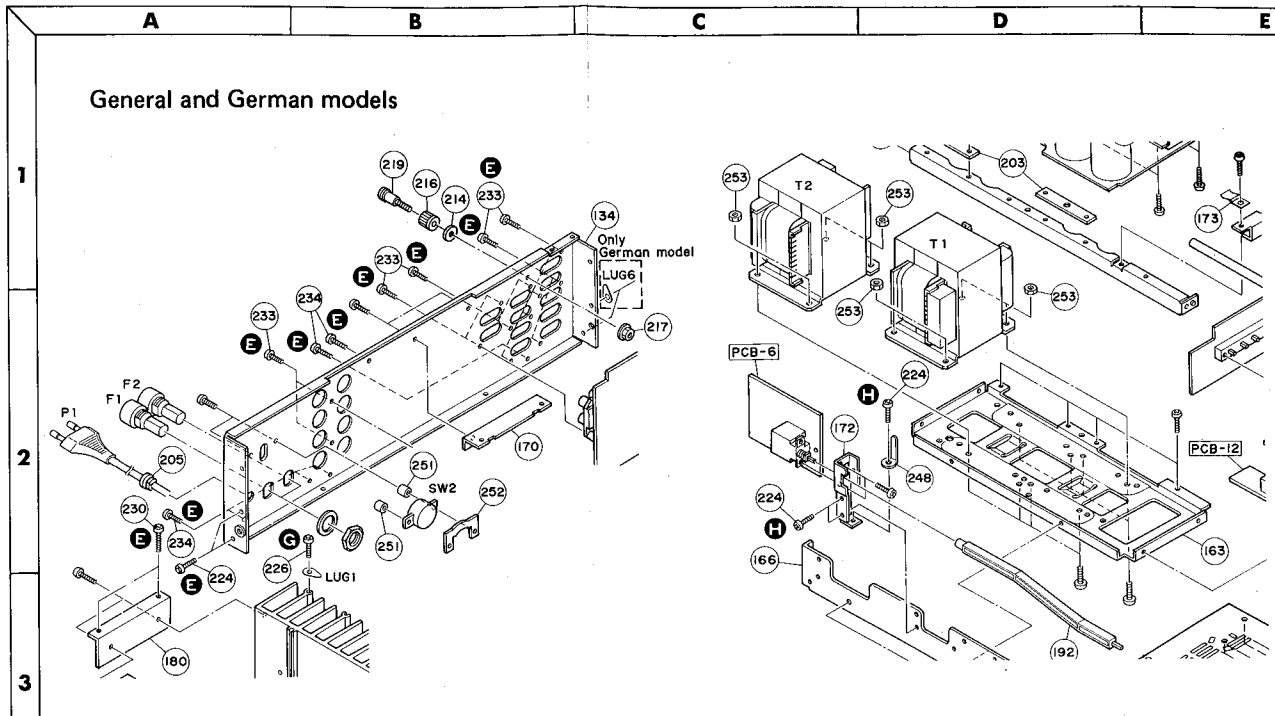

GENERAL UNIT PARTS LIST

Ref. No.	Part No.	Description
101	A443-PM665A	Front Panel Assembly
102	A630-PM665A	Knob Assembly, Bass, Treble, Balance, Tape Monitor, Tape Out, Function, Speaker System Selector
103	A630-PM665B	Knob Assembly, Volume
104	A662-PM665A	Push Button Assembly, Bass Turnover, Tone Defeat, Treble Turnover, Pre-out Main-in, Bass Contour, Subsonic, High Cut, Mode, Cartridge
105	A660-PM665A	Push Button Assembly, Power
106	B211-PM665A	Chassis Assembly
132	1414-05501	Cabinet Top
133	1423-02201	Cabinet Bottom
134	1424-14801	Cabinet Back (for U.S.A. and Canada models)
"	1424-14901	Cabinet Back (for General and German models)
145	1662-18101	Push Button, Mute
148	1634-04501	Knob, Cap. Trim
151	1319-0139	Foot
163	2219-8036	Bracket
164	2219-8037	Bracket
165	2219-8009	Bracket
166	2219-8010	Bracket
167	2219-8011	Bracket
168	2219-8038	Bracket
169	2219-8013	Bracket
170	2219-8040	Bracket
171	2219-8039	Bracket
172	2219-8034	Bracket
173	2219-8044	Bracket
174	2219-7879	Bracket
179	2222-7180	Heat Sink (for U.S.A. and Canada models)
"	2222-7187	Heat Sink (for General and German models)
180	2222-7182	Heat Sink
181	2222-7183	Heat Sink
182	2222-7181	Heat Sink

Ref. No.	Part No.	Description
185	2240-7183	Protector
186	2240-7239	Holder
189	2240-7120	Holder
190	2240-7240	Holder
192	2601-7150	Shaft
193	2224-7101	Insulator
195	2601-7153	Shaft
196	2601-7151	Shaft
199	2651-210189	Spring
201	2132-7126	Spacer
202	2132-7135	Spacer
203	2224-7100	Insulator
204	2651-2101710	Spring
205	2114-415027	Bushing
206	2224-7101	Insulator
207	2132-7137	Spacer
210	1568-00301	Frame
211	2132-7136	Spacer
213	2410-100	Special Washer
214	2410-7005	Special Washer
216	2440-7011	Special Nut
217	2440-7016	Special Nut
218	2132-01702	Spacer
219	2310-7015	Special Screw
221	2461-501	E-Stop Ring
222	2459-3003511	Snap-in-fastener
224	2347-300627	Self-tapping Screw (+) (3 x 6mm)
230	2347-301047	Self-tapping Screw (+) (3 x 10mm)
232	2347-400847	Self-tapping Screw (+) (4 x 8 mm)
234	2347-300647	Self-tapping Screw (+) (3 x 6mm)
235	2347-300827	Self-tapping Screw (+) (3 x 8mm)
240	2396-300549	Hexagon-socket-head Screw (3 x 5mm)
248	2218-20	Bracket
251	2132-7116	Spacer (only General and German models)
252	2440-7017	Special Nut (only General and German models)
253	2440-60	Special Nut (only General and German models)
	1111-J30199	Owner Guide (for U.S.A. model)
	1111-J30200	Owner Guide (for Canada, General and German models)
	1221-787143	Packing Box
	1222-7225	Packing Cushion, Right
	1222-7226	Packing Cushion, Left

ELECTRICAL PARTS LIST

Ref. No.	Part No.	Description
CHASSIS MISCELLANEOUS		
△ P1	4161-71151	Power Cord (for U.S.A. and Canada models)
△ "	4161-7256	Power Cord (for General and German models)
△ T1, 2	5584-701492	Power Transformer (for U.S.A. and Canada models)
△ "	5584-701493	Power Transformer (for General and German models)
△ F1, 2	5732-502029	Fuse, 5A, 125V (for U.S.A. and Canada models)
△ "	5732-252030	Fuse, T2.5A, 250V (for General and German models)
△ CN1	4443-712	Connector, Power Cord (only General and German models)
△ SO1/2/3	4474-156	AC Outlet, Unswitched, Switched (only U.S.A. and Canada models)
△ SW2	4411-102729	Rotary Switch, Voltage Selector (only General and German models)
SW701A	4423-04570110	Remote Switch, Phono 2 Cartridge
LUG1, 2, 3, 4, 5	4211-5005	Lug Terminal
LUG6, 7, 8	4211-4	Lug Terminal (only German model)
△	4472-014	Fuse Holder (for U.S.A. and Canada models)
△	4472-7118	Fuse Holder (for General and German models)
	4442-14	Pin Plug (for Phono Input Jacks) (Accessory)

Ref. No.	Part No.	Description
PCB-1 MAIN P.C. BOARD		
RESISTORS		
△ R1, 3	5102-8204713	82Ω, ±2%, 1/4W, Fuse
△ R25	5102-6804713	68Ω, ±2%, 1/4W, Fuse
R483, 484, 485, 486	5275-R33671	0.33Ω, ±10%, 5W x 2, Cement (Special Dual)
R487, 488, 489, 490	5173-5R6571	5.6Ω, ±5%, 2W, Metal
R491, 492	5171-220572	22Ω, ±5%, 1W, Metal
CAPACITORS		
C11	5345-336B0951	33μF, ±20%, 10V, Electrolytic
C16	5345-476F041	47μF, ±20%, 50V, Electrolytic
C27	5345-475F0952	4.7μF, ±20%, 50V, Electrolytic
C28	5345-107C041	100μF, ±20%, 16V, Electrolytic
C29	5345-476C041	47μF, ±20%, 16V, Electrolytic
C60, 61	5352-1040962	0.1μF, ±20%, 400V, Metalized Polyester (only German model)
TRANSISTORS		
Q1, 3	5613-2603(E)	2SC2603(E) or 2SC2603(F)
Q2, 4, 7	5611-1115(E)	2SA1115(E) or 2SA1115(F)
Q8	5613-1845(E)	2SC1845(E) or 2SC1845(F)
Q9, 10	5611-992(E)	2SA992(E) or 2SA992(F)
Q13	5611-965(O)	2SA965(O) or 2SA965(Y)
Q441, 442, 445, 446	5613-3281(O)	2SC3281(O) or 2SC3281(R)
Q443, 444, 447, 448	5611-1302(O)	2SA1302(O) or 2SA1302(R)
DIODES		
D3, 4	5632-DS135E	DS135E
D5	5635-HZ6A-2L	Zener, HZ6A-2L
D6, 8	5631-1S2473	1S2473
D7	5635-HZ15-2L	Zener, HZ15-2L
D405, 406, 407, 408	5632-10DF2	10DF2
D409, 410	5641-MV12YM	Varistor, MV12YM
COILS		
L401, 402, 403, 404	5597-45502	Ferrite Bead
L405, 406	5991-7165	
MISCELLANEOUS		
CN101, 102	4443-030185	Connector, 3 Pos.

Ref. No.	Part No.	Description
PCB-2 EQUALIZER P.C. BOARD		
RESISTORS		
R621, 622, 717, 718, 719, 720	5174-561381	560Ω, ±1%, 1/4W, Metal
R627, 628	5174-102381	1kΩ, ±1%, 1/4W, Metal
R645, 646	5174-Z549338	549kΩ, ±1%, 1/4W, Metal
R647, 648	5174-Z412238	41.2kΩ, ±1%, 1/4W, Metal
△ R657, 658	5102-2704713	27Ω, ±2%, 1/4W, Fuse
R661, 662	5174-Z169338	169kΩ, ±1%, 1/4W, Metal
CAPACITORS		
C601, 602	5345-106D0951	10μF, ±20%, 25V, Electrolytic
C603, 604	5353-680534	68pF, ±5%, 500V, Mica
C605, 606	5359-1015851	100pF, ±5%, 100V, Polypropylene
C607, 608	5345-477B0952	470μF, ±20%, 10V, Electrolytic
C609, 610	5345-226C041	22μF, ±20%, 16V, Electrolytic
C617, 618	5359-2025851	2000pF, ±5%, 100V, Polypropylene
C621, 622, 623, 624	5345-226D0226	22μF, ±20%, 25V, Electrolytic
C625, 626, 627, 628	5345-337D041	330μF, ±20%, 25V, Electrolytic
C651, 652	5359-3315851	330pF, ±5%, 100V, Polypropylene
C681, 682	5353-330534	33pF, ±5%, 500V, Mica (only German model)
C685, 686	5359-2715851	270pF, ±5%, 100V, Polypropylene (only German model)
C703, 704, 705, 706	5345-106F0226	10μF, ±20%, 50V, Electrolytic
C707, 708, 709, 710	5345-337C041	330μF, ±20%, 16V, Electrolytic
C711, 712	5345-476B0951	47μF, ±20%, 10V, Electrolytic

Ref. No.	Part No.	Description
185	2240-7183	Protector
186	2240-7239	Holder
189	2240-7120	Holder
190	2240-7240	Holder
192	2601-7150	Shaft
193	2224-7101	Insulator
195	2601-7153	Shaft
196	2601-7151	Shaft
199	2651-210189	Spring
201	2132-7126	Spacer
202	2132-7135	Spacer
203	2224-7100	Insulator
204	2651-2101710	Spring
205	2114-415027	Bushing
206	2224-7101	Insulator
207	2132-7137	Spacer
210	1568-00301	Frame
211	2132-7136	Spacer
213	2410-100	Special Washer
214	2410-7005	Special Washer
216	2440-7011	Special Nut
217	2440-7016	Special Nut
218	2132-01702	Spacer
219	2310-7015	Special Screw
221	2461-501	E-Stop Ring
222	2459-3003511	Snap-in-fastener
224	2347-300627	Self-tapping Screw (+) (3 x 6mm)
230	2347-301047	Self-tapping Screw (+) (3 x 10mm)
232	2347-400847	Self-tapping Screw (+) (4 x 8 mm)
234	2347-300647	Self-tapping Screw (+) (3 x 6mm)
235	2347-300827	Self-tapping Screw (+) (3 x 8mm)
240	2396-300549	Hexagon-socket-head Screw (3 x 5mm)
248	2218-20	Bracket
251	2132-7116	Spacer (only General and German models)
252	2440-7017	Special Nut (only General and German models)
253	2440-60	Special Nut (only General and German models)
	1111-J30199	Owner Guide (for U.S.A. model)
	1111-J30200	Owner Guide (for Canada, General and German models)
	1221-787143	Packing Box
	1222-7225	Packing Cushion, Right
	1222-7226	Packing Cushion, Left

ELECTRICAL PARTS LIST

Ref. No.	Part No.	Description
CHASSIS MISCELLANEOUS		
△ P1	4161-71151	Power Cord (for U.S.A. and Canada models)
△ "	4161-7256	Power Cord (for General and German models)
△ T1, 2	5584-701492	Power Transformer (for U.S.A. and Canada models)
△ "	5584-701493	Power Transformer (for General and German models)
△ F1, 2	5732-502029	Fuse, 5A, 125V (for U.S.A. and Canada models)
△ "	5732-252030	Fuse, T2.5A, 250V (for General and German models)
△ CN1	4443-712	Connector, Power Cord (only General and German models)
△ SO1/2/3	4474-156	AC Outlet, Unswitched, Switched (only U.S.A. and Canada models)
△ SW2	4411-102729	Rotary Switch, Voltage Selector (only General and German models)
SW701A	4423-04570110	Remote Switch, Phono 2 Cartridge
LUG1, 2, 3, 4, 5	4211-5005	Lug Terminal
LUG6, 7, 8	4211-4	Lug Terminal (only German model)
△	4472-014	Fuse Holder (for U.S.A. and Canada models)
△	4472-7118	Fuse Holder (for General and German models)
	4442-14	Pin Plug (for Phono Input Jacks) (Accessory)

Ref. No.	Part No.	Description
PCB-1 MAIN P.C. BOARD		
RESISTORS		
△ R1, 3	5102-8204713	82Ω, ±2%, 1/4W, Fuse
△ R25	5102-6804713	68Ω, ±2%, 1/4W, Fuse
R483, 484, 485, 486	5275-R33671	0.33Ω, ±10%, 5W x 2, Cement (Special Dual)
R487, 488, 489, 490	5173-5R6571	5.6Ω, ±5%, 2W, Metal
R491, 492	5171-220572	22Ω, ±5%, 1W, Metal
CAPACITORS		
C11	5345-336B0951	33μF, ±20%, 10V, Electrolytic
C16	5345-476F041	47μF, ±20%, 50V, Electrolytic
C27	5345-475F0952	4.7μF, ±20%, 50V, Electrolytic
C28	5345-107C041	100μF, ±20%, 16V, Electrolytic
C29	5345-476C041	47μF, ±20%, 16V, Electrolytic
C60, 61	5352-1040962	0.1μF, ±20%, 400V, Metalized Polyester (only German model)
TRANSISTORS		
Q1, 3	5613-2603(E)	2SC2603(E) or 2SC2603(F)
Q2, 4, 7	5611-1115(E)	2SA1115(E) or 2SA1115(F)
Q8	5613-1845(E)	2SC1845(E) or 2SC1845(F)
Q9, 10	5611-992(E)	2SA992(E) or 2SA992(F)
Q13	5611-965(O)	2SA965(O) or 2SA965(Y)
Q441, 442, 445, 446	5613-3281(O)	2SC3281(O) or 2SC3281(R)
Q443, 444, 447, 448	5611-1302(O)	2SA1302(O) or 2SA1302(R)
DIODES		
D3, 4	5632-DS135E	DS135E
D5	5635-HZ6A-2L	Zener, HZ6A-2L
D6, 8	5631-1S2473	1S2473
D7	5635-HZ15-2L	Zener, HZ15-2L
D405, 406, 407, 408	5632-10DF2	10DF2
D409, 410	5641-MV12YM	Varistor, MV12YM
COILS		
L401, 402, 403, 404	5597-45502	Ferrite Bead
L405, 406	5991-7165	
MISCELLANEOUS		
CN101, 102	4443-030185	Connector, 3 Pos.

PCB-2 EQUALIZER P.C. BOARD		
RESISTORS		
R621, 622, 717, 718, 719, 720	5174-561381	560Ω, ±1%, 1/4W, Metal
R627, 628	5174-102381	1kΩ, ±1%, 1/4W, Metal
R645, 646	5174-Z549338	549kΩ, ±1%, 1/4W, Metal
R647, 648	5174-Z412238	41.2kΩ, ±1%, 1/4W, Metal
△ R657, 658	5102-2704713	27Ω, ±2%, 1/4W, Fuse
R661, 662	5174-Z169338	169kΩ, ±1%, 1/4W, Metal
CAPACITORS		
C601, 602	5345-106D0951	10μF, ±20%, 25V, Electrolytic
C603, 604	5353-680534	68pF, ±5%, 500V, Mica
C605, 606	5359-1015851	100pF, ±5%, 100V, Polypropylene
C607, 608	5345-477B0952	470μF, ±20%, 10V, Electrolytic
C609, 610	5345-226C041	22μF, ±20%, 16V, Electrolytic
C617, 618	5359-2025851	2000pF, ±5%, 100V, Polypropylene
C621, 622, 623, 624	5345-226D0226	22μF, ±20%, 25V, Electrolytic
C625, 626, 627, 628	5345-337D041	330μF, ±20%, 25V, Electrolytic
C651, 652	5359-3315851	330pF, ±5%, 100V, Polypropylene
C681, 682	5353-330534	33pF, ±5%, 500V, Mica (only German model)
C685, 686	5359-2715851	270pF, ±5%, 100V, Polypropylene (only German model)
C703, 704, 705, 706	5345-106F0226	10μF, ±20%, 50V, Electrolytic
C707, 708, 709, 710	5345-337C041	330μF, ±20%, 16V, Electrolytic
C711, 712	5345-476B0951	47μF, ±20%, 10V, Electrolytic

Ref. No.	Part No.	Description
TRANSISTORS		
Q601, 602, 603, 604	5613-2240(BL)	2SC2240(BL)
Q605, 606, 607, 608, 709, 712	5613-2603(E)	2SC2603(E) or 2SC2603(F)
Q609, 610, 613, 614	5611-999L(F)	2SA999L(F)
Q611, 612	5613-2320L(F)	2SC2320L(F)
Q615, 616	5612-646(C)	2SB646(C)
Q617, 618	5614-666(C)	2SD666(C)
Q619, 620	5614-667(C)	2SD667(C)
Q621, 622	5612-647(C)	2SB647(C)
Q623	5614-669(C)	2SD669(C)
Q624	5612-649(C)	2SB649(C)
Q701, 702, 707, 708	5611-1190(E)	2SA1190(E)
Q703, 704, 705, 706	5613-2855(D)	2SC2855(D)
Q710, 711	5611-1115(E)	2SA1115(E) or 2SA1115(F)
Q713, 714	5616-2SK373GR	F.E.T., 2SK373(GR)
Q803, 804	5611-1115(E)	2SA1115(E)
Q805, 806	5616-2SK364(V)	F.E.T., 2SK364(V) or 2SK364(BL)
DIODES		
D601, 602	5631-1S2473	1S2473
D603, 604	5641-MV103	Varistor, MV103
D605, 606	5635-HZ24-2L	Zener, HZ24-2L
D701, 702	5635-HZ15-2L	Zener, HZ15-2L
COILS		
L701, 702, 703, 704	5597-3	Ferrite Bead (only German model)
MISCELLANEOUS		
SW701B	4422-70211	Remote Switch, Phono 2 Cartridge
J501/502/503/504/505/ 506	4486-9	6-Pin Jack, Tuner, CD, Video/Aux
J601/602/603/604	4484-31	4-Pin Jack, Phono 1 (MM), Phono 2 (MM/MC)
CN304	4443-070185	Connector, 7 Pos.
CN501, 507, 515	4443-030185	Connector, 3 Pos.
PCB-3 DRIVER P.C. BOARD		
RESISTORS		
△ R407, 408, 409, 410	5102-1824713	1.8k Ω , \pm 2%, 1/4W, Fuse
R423, 424	5174-511381	510 Ω , \pm 1%, 1/4W, Metal
R425, 426	5174-270381	27 Ω , \pm 1%, 1/4W, Metal
△ R427, 428, 429, 430	5102-1224713	1.2k Ω , \pm 2%, 1/4W, Fuse
R433, 434	5174-243381	24k Ω , \pm 1%, 1/4W, Metal
R439, 440, 441, 442	5174-222381	2.2k Ω , \pm 1%, 1/4W, Metal
△ R443, 444, 445, 446, 451, 452, 453, 454	5102-2214713	220 Ω , \pm 2%, 1/4W, Fuse
R447, 448, 449, 450	5174-153381	15k Ω , \pm 1%, 1/4W, Metal
△ R461, 462, 463, 464	5102-1005711	10 Ω , \pm 5%, 1W, Fuse
△ R465, 466, 467, 468	5102-1014713	100 Ω , \pm 2%, 1/4W, Fuse
△ R469, 470, 471, 472	5102-3R3579	3.3 Ω , \pm 5%, 1/4W, Fuse
△ R481, 482	5102-8204713	82 Ω , \pm 2%, 1/4W, Fuse
CONTROLS		
VR401, 402	5101-6838875	68k Ω
VR403, 404	5101-4717675	470 Ω
CAPACITORS		
C3, 4, 5, 6	5352-1041957	0.1 μ F, \pm 10%, 250V, Metalized Polyester
△ C7, 8, 9, 10	5341-109G0958	10000 μ F, \pm 20%, 63V, Electrolytic
C401, 402	5345-107B0951	100 μ F, \pm 20%, 10V, Electrolytic
C403, 404	5359-2715851	270pF, \pm 5%, 100V, Polypropylene
C405, 406	5345-107D041	100 μ F, \pm 20%, 25V, Electrolytic
C407, 408	5353-040934	4pF, \pm 0.5pF, 500V, Mica
C409, 410	5353-680534	68pF, \pm 5%, 500V, Mica
C411, 412, 417, 418	5345-106C0951	10 μ F, \pm 20%, 16V, Electrolytic
△ C413, 414, 415, 416	5345-477G0962	470 μ F, \pm 20%, 63V, Electrolytic
C423, 424, 425, 426	5352-1041960	0.1 μ F, \pm 10%, 100V, Metalized Polyester

Ref. No.	Part No.	Description
	TRANSISTORS	
Q401, 402	5616-2SK364(V)	F.E.T., 2SK364(V) or 2SK364(BL)
Q403, 404, 405, 406	5613-2240(BL)	2SC2240(BL)
Q407, 408, 409, 410, 419, 420, 429, 430	5613-1845(E)	2SC1845(E) or 2SC1845(F)
Q411, 412	5611-1145(O)	2SA1145(O) or 2SA1145(Y)
Q413, 414	5613-2320L(F)	2SC2320L(F)
Q415, 416	5611-999L(F)	2SA999L(F)
Q417, 418	5611-992(E)	2SA992(E)
Q421, 422, 425, 426	5611-1285(F)	2SA1285(F)
Q423, 424, 427, 428	5613-3245(F)	2SC3245(F)
Q433, 434	5613-2235(O)	2SC2235(O) or 2SC2235(Y)
Q435, 436	5611-965(O)	2SA965(O) or 2SA965(Y)
Q437, 438	5611-968(O)	2SA968(O) or 2SA968(Y)
Q439, 440	5613-2238(O)	2SC2238(O) or 2SC2238(Y)
	DIODES	
△ D13, 14	5685-D5FB20F1	Bridge Silicon, D5FB20F1
D401, 402	5631-1S2473	1S2473
D403, 404	5635-HZ15-2L	Zener, HZ15-2L
	MISCELLANEOUS	
CN103	4443-030185	Connector, 3 Pos.
PCB-4 TONE CONTROL P.C. BOARD		
	RESISTORS	
△ R49, 50	5102-1214713	120Ω, ±2%, 1/4W, Fuse
△ R61, 62	5102-2714713	270Ω, ±2%, 1/4W, Fuse
	CONTROLS	
VR501, 502	5113-50396122	50kΩMN, Balance (w/Hexagon Nut)
VR505, 506	5113-50373148	50kΩC, Treble (w/Hexagon Nut)
VR507, 508	5113-10474148	100kΩC, Bass (w/Hexagon Nut)
	CAPACITORS	
C17, 18, 905, 906	5345-107D041	100μF, ±20%, 25V, Electrolytic
C21, 22, 63, 64, 543, 544, 911, 912	5345-227D041	220μF, ±20%, 25V, Electrolytic
C61, 62	5345-107C041	100μF, ±20%, 16V, Electrolytic
C501, 502	5359-1815851	180pF, ±5%, 100V, Polypropylene
C507, 508	5345-106C0951	10μF, ±20%, 16V, Electrolytic
C513, 514	5345-226D0951	22μF, ±20%, 25V, Electrolytic
C519, 520	5345-476C0951	47μF, ±20%, 16V, Electrolytic
C901, 902	5345-104F0951	0.1μF, ±20%, 50V, Electrolytic
C909, 910	5345-224F0951	0.22μF, ±20%, 50V, Electrolytic
	TRANSISTORS	
Q5, 11	5613-2235(O)	2SC2235(O) or 2SC2235(Y)
Q6, 12	5611-965(O)	2SA965(O) or 2SA965(Y)
Q73, 505, 506, 507, 508, 511, 512	5613-2603(E)	2SC2603(E) or 2SC2603(F)
Q74, 509, 510, 513, 514	5611-1115(E)	2SA1115(E) or 2SA1115(F)
Q501, 502, 503, 504	5613-2320L(F)	2SC2320L(F)
Q515, 516	5612-992(E)	2SB992(E)
Q517, 518	5614-1845(E)	2SD1845(E)
Q901, 902, 905, 906, Q903, 904	5613-2603(F) 5611-1115(F)	2SC2603(F) or 2SC2603(E) 2SA1115(F) or 2SA1115(E)
	DIODES	
D9, 10	5635-HZ24-2L	Zener, HZ24-2L
D11, 12	5635-HZ15-2L	Zener, HZ15-2L
D503, 504	5631-1S2473	1S2473
	MISCELLANEOUS	
SW101	4611-057016	Rotary Slide Switch, Function (w/Hexagon Nut)
SW102	4412-045752	Rotary Slide Switch, Tape Out (w/Hexagon Nut)
SW103	4412-043742	Rotary Slide Switch, Tape Monitor (w/Hexagon Nut)

Ref. No.	Part No.	Description
PCB-5 PUSH-SWITCHES P.C. BOARD		
CAPACITORS		
C71	5345-226C041	22 μ F, \pm 20%, 16V, Electrolytic
C75, 76	5345-106C0951	10 μ F, \pm 20%, 16V, Electrolytic
C511, 512	5353-010934	1pF, \pm 0.5pF, 500V, Mica
C515, 516, 517, 518	5353-330534	33pF, \pm 5%, 500V, Mica
C539, 540	5359-2025851	2000pF, \pm 5%, 100V, Polypropylene
TRANSISTORS		
Q71, 75, 76	5611-1115(E)	2SA1115(E) or 2SA1115(F)
Q72	5613-2603(E)	2SC2603(E) or 2SC2603(F)
Q77, 78	5616-2SK363(V)	F.E.T., 2SK363(V) or 2SK363(BL)
DIODES		
D52, 53, 54, 55, 56, 57, 58	5637-GL5HD10	L.E.D., GL5HD10, Red, Phono 1, Phono 2, Tuner, CD, Video/Aux, Tape 2, Tape 1
D59	5637-5NG510(C)	L.E.D., GL5NG510(C) or GL5NG510(D), Green, Mute
D71	5631-1S2473	1S2473
MISCELLANEOUS		
SW501	4431-A027161	Push Switch, Mute
SW502/503/504/505/506	4431-05127159	Push Switch, Mode, High Cut, Subsonic, Bass Contour, Pre-out/Main-in
SW507/508/509/510/511	4431-05127259	Push Switch, Treble Turnover, Tone Defeat, Bass Turnover
PCB-6 POWER SWITCH P.C. BOARD		
Δ R101	5135-335J50P	Resistor, 3.3M Ω , \pm 5%, 1/2W, Carbon (only General and German models)
Δ C1	5352-1030959	Capacitor, 0.01 μ F, \pm 20%, AC125V, Metalized Polyester (for U.S.A. and Canada models)
Δ "	5352-1030958	Capacitor, 0.01 μ F, \pm 20%, AC250V, Metalized Polyester (for General and German models)
Δ SW1	4431-A027160	Push Switch, Power
PCB-7 SPEAKERS P.C. BOARD		
SW401	4411-204715	Rotary Switch, Speaker System Selector (w/Hexagon Nut)
TE401	4214-156	Terminal, Speaker System 1/2
PCB-8 VOLUME CONTROL P.C. BOARD		
VR503, 504	5113-10472147	Control, 100k Ω B, Volume (w/Hexagon Nut)
CN514	4443-030185	Connector, 3 Pos.
PCB-9 CAPACITANCE TRIM P.C. BOARD		
CAPACITORS		
C653, 654	5359-1515851	150pF, \pm 5%, 100V, Polypropylene
C655, 656	5359-5115851	510pF, \pm 5%, 100V, Polypropylene
MISCELLANEOUS		
SW651	4411-204714	Rotary Switch, Cap. Trim (w/Hexagon Nut)
PCB-10 POWER INDICATOR P.C. BOARD		
C35, 74	5345-106C0951	Capacitor, 10 μ F, \pm 20%, 16V, Electrolytic
D51	5637-GL5HD10	L.E.D., GL5HD10, Red, Power Indicator
PCB-11 INPUT/OUTPUT JACKS P.C. BOARD		
J507/508/509/510, 511/512/513/514, 515/516/517/518	4484-27	4-Pin Jack, Tape 1 In/Out, Tape 2 In/Out, Pre-out, Main-in
PCB-12 HEADPHONES P.C. BOARD		
J401	4451-00159	Jack, Headphones

 SAFETY RELATED COMPONENT. USE ONLY EXACT REPLACEMENT PART AS SPECIFIED.

SCHEMATIC DIAGRAM

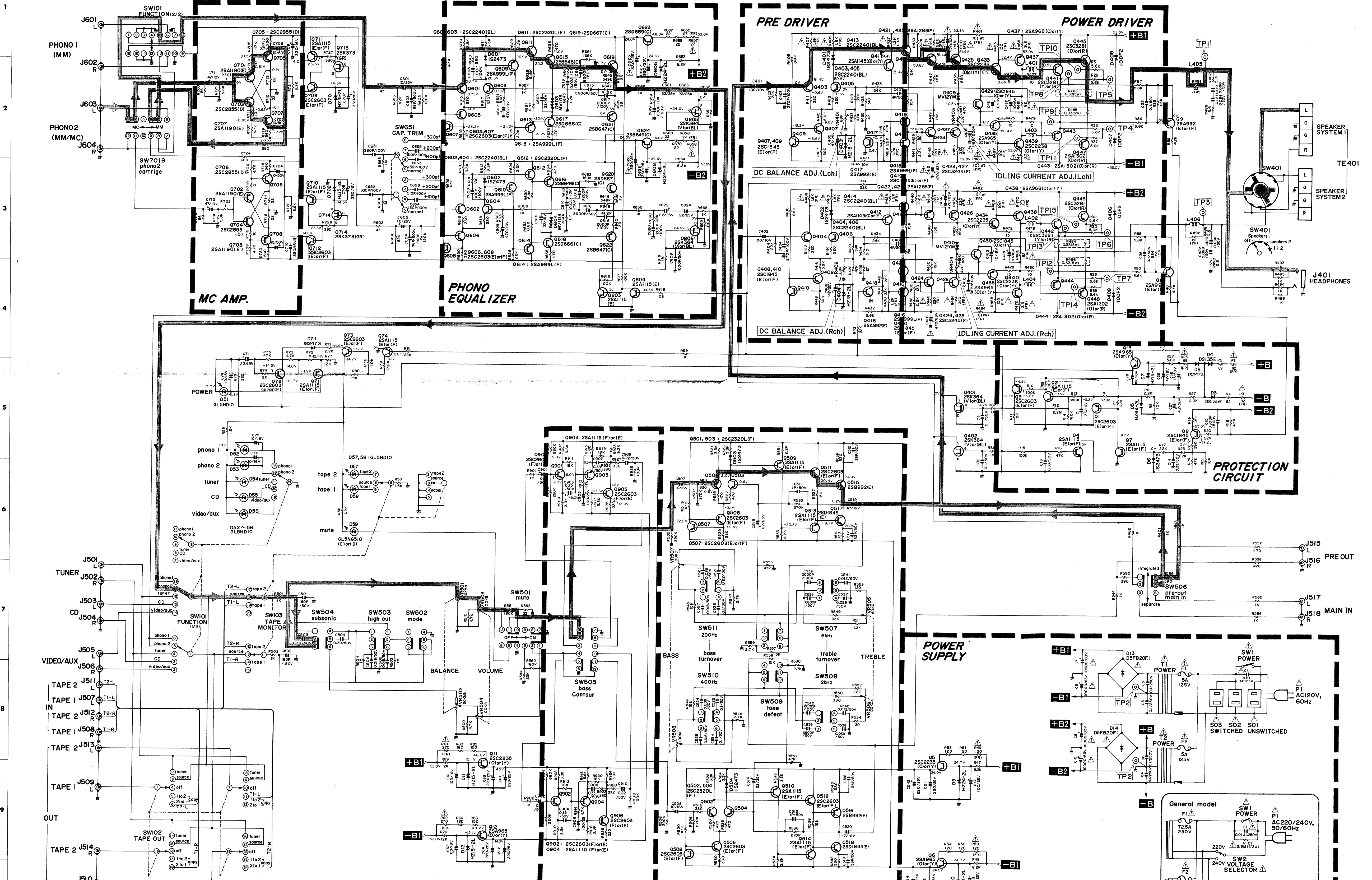

1. ALL RESISTANCES VALUES ARE IN Ω.
KΩ=1000Ω, MΩ=1000KΩ.
2. THE WATTAGE OF RESISTORS IS 1/4W UNLESS OTHERWISE NOTED.
3. ALL CAPACITANCES VALUES ARE IN μF UNLESS OTHERWISE NOTED. P=μF
4. . . . V : DC VOLTAGE AT NO SIGNAL
5. SAFETY-REQUIREMENTS COMPONENTS IN ACCORDANCE WITH PRESENT SAFETY REGULATIONS, THESE COMPONENTS MUST ONLY BE REPLACED BY ORIGINAL PARTS.

A **F** **C** **D**

SCHEMATIC DIAGRAM

1
2
3
4
5
6

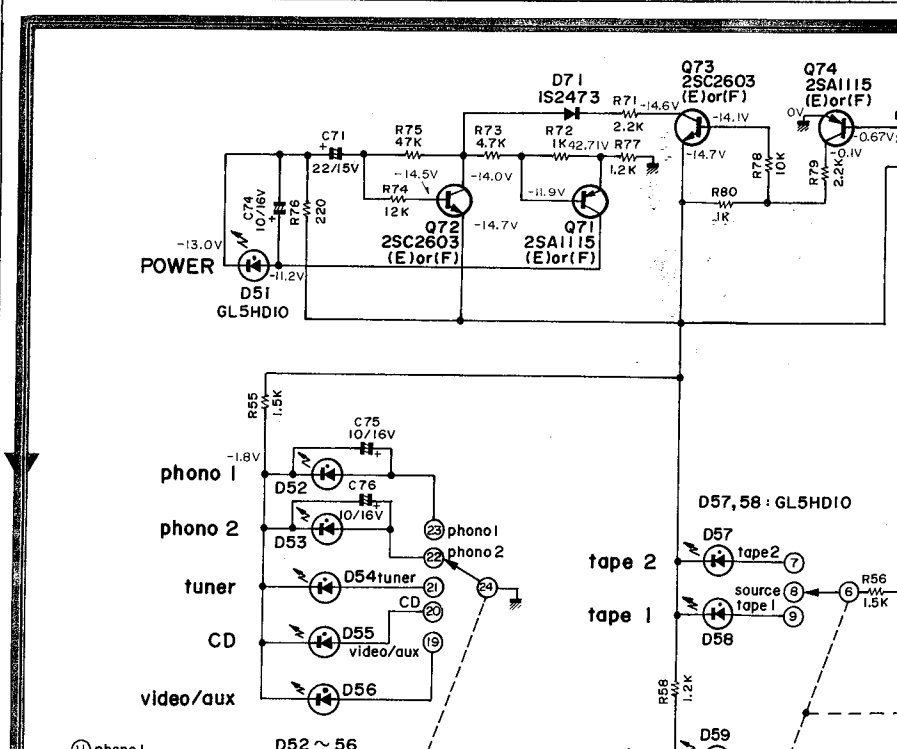
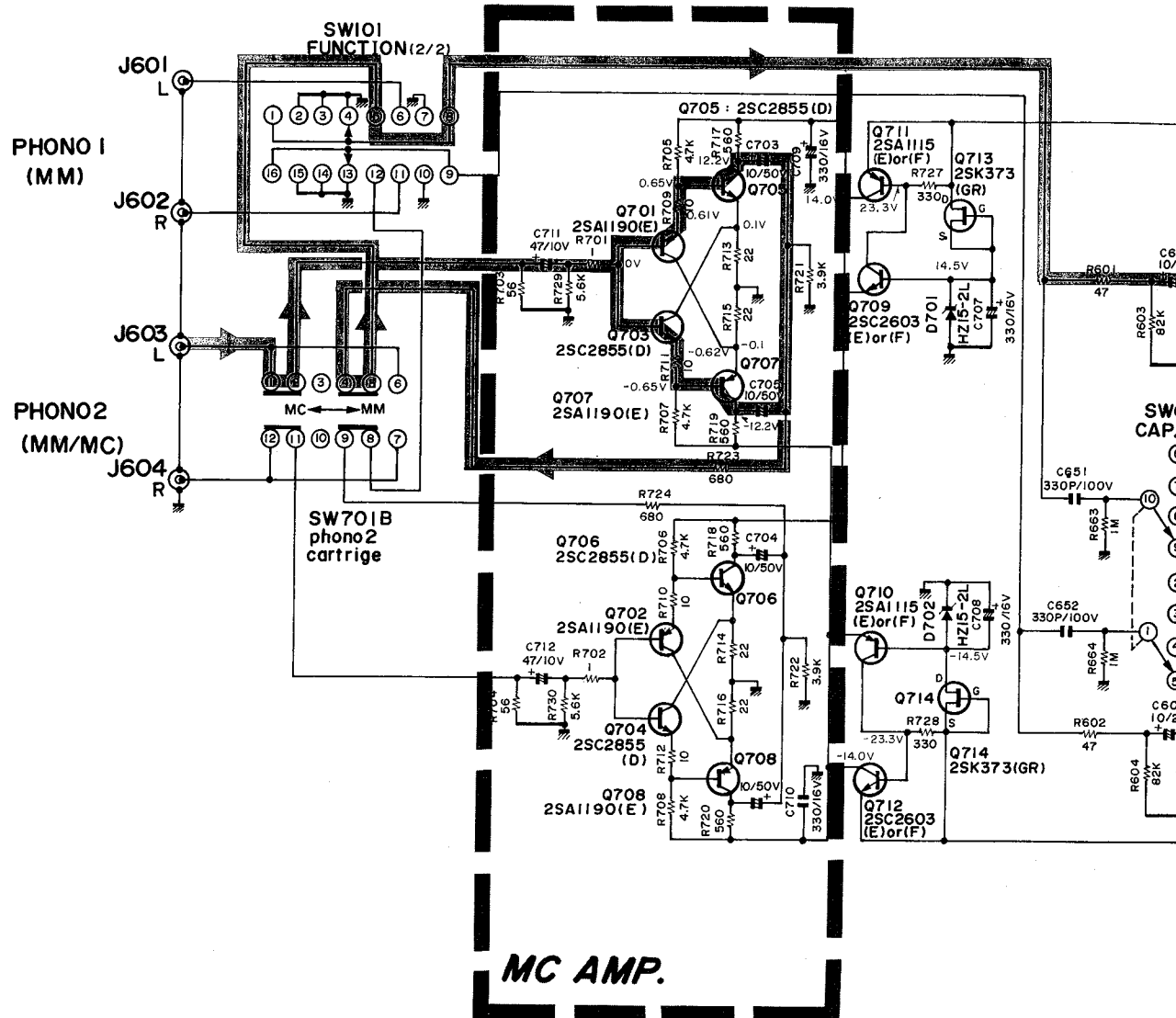

Ⓜ phono 1

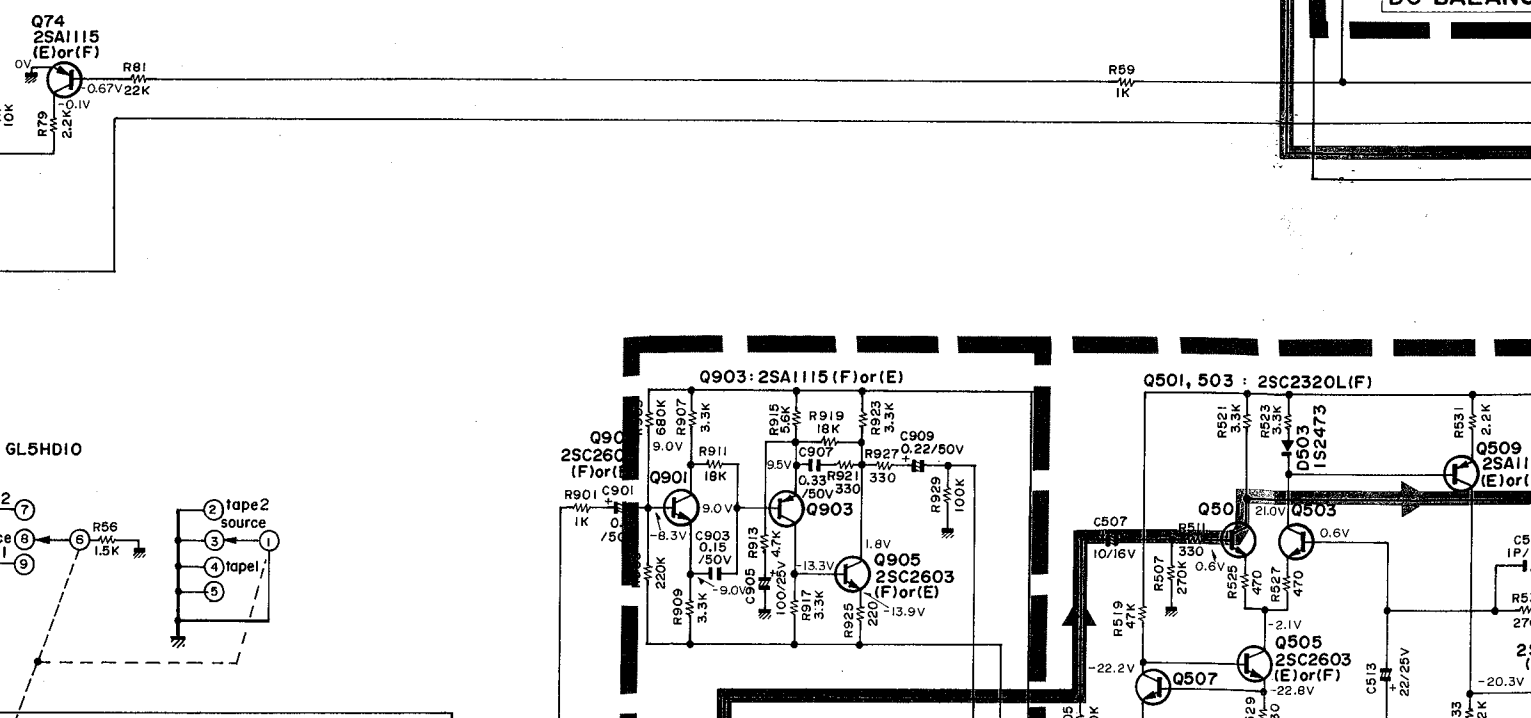
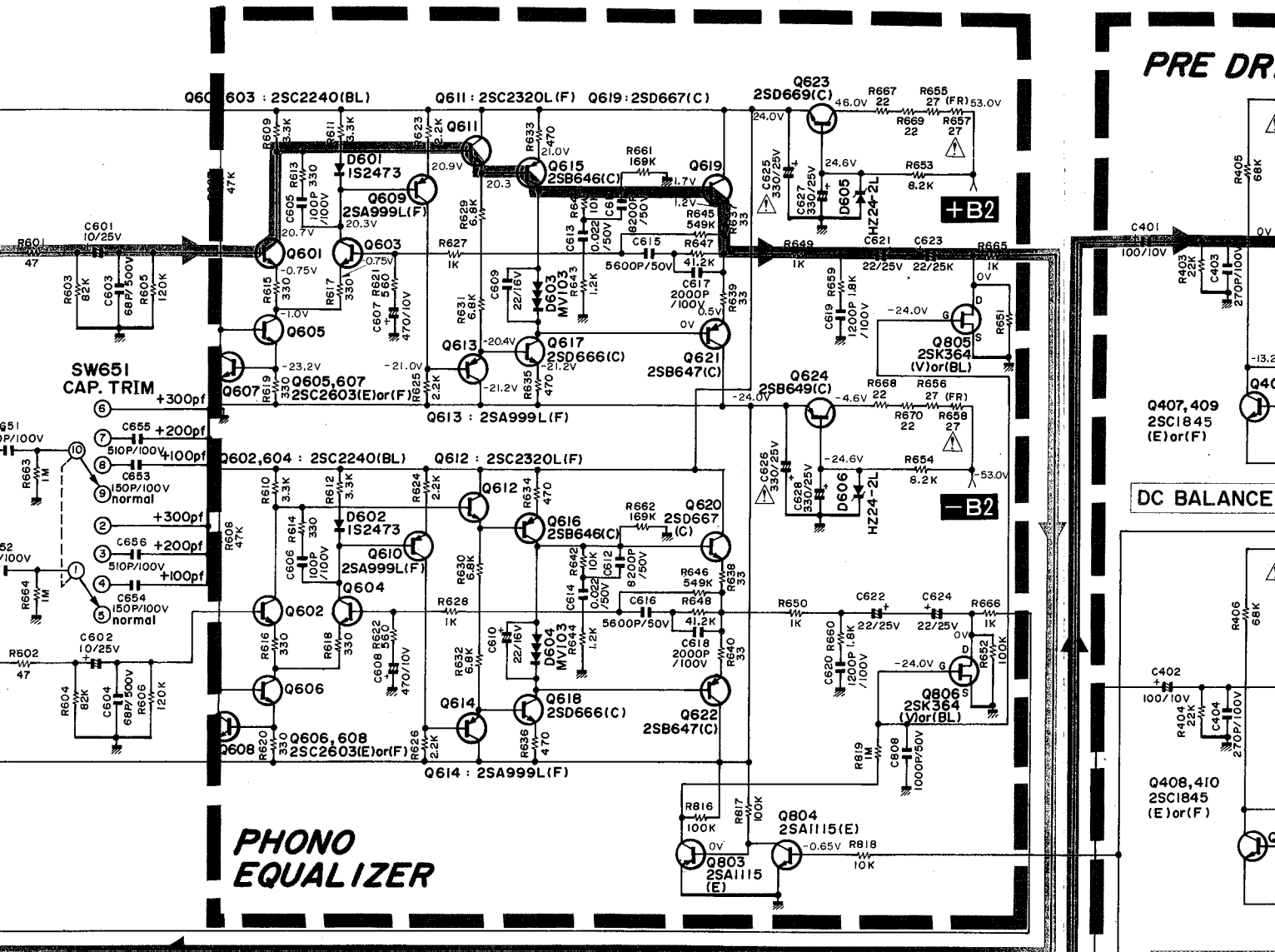

POWER DRIVER

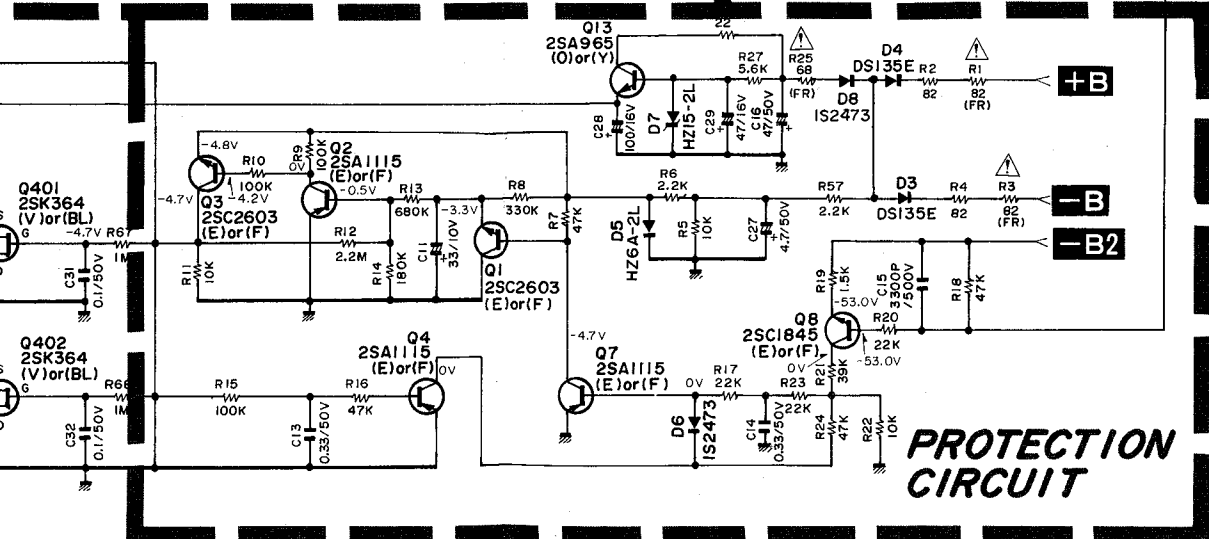
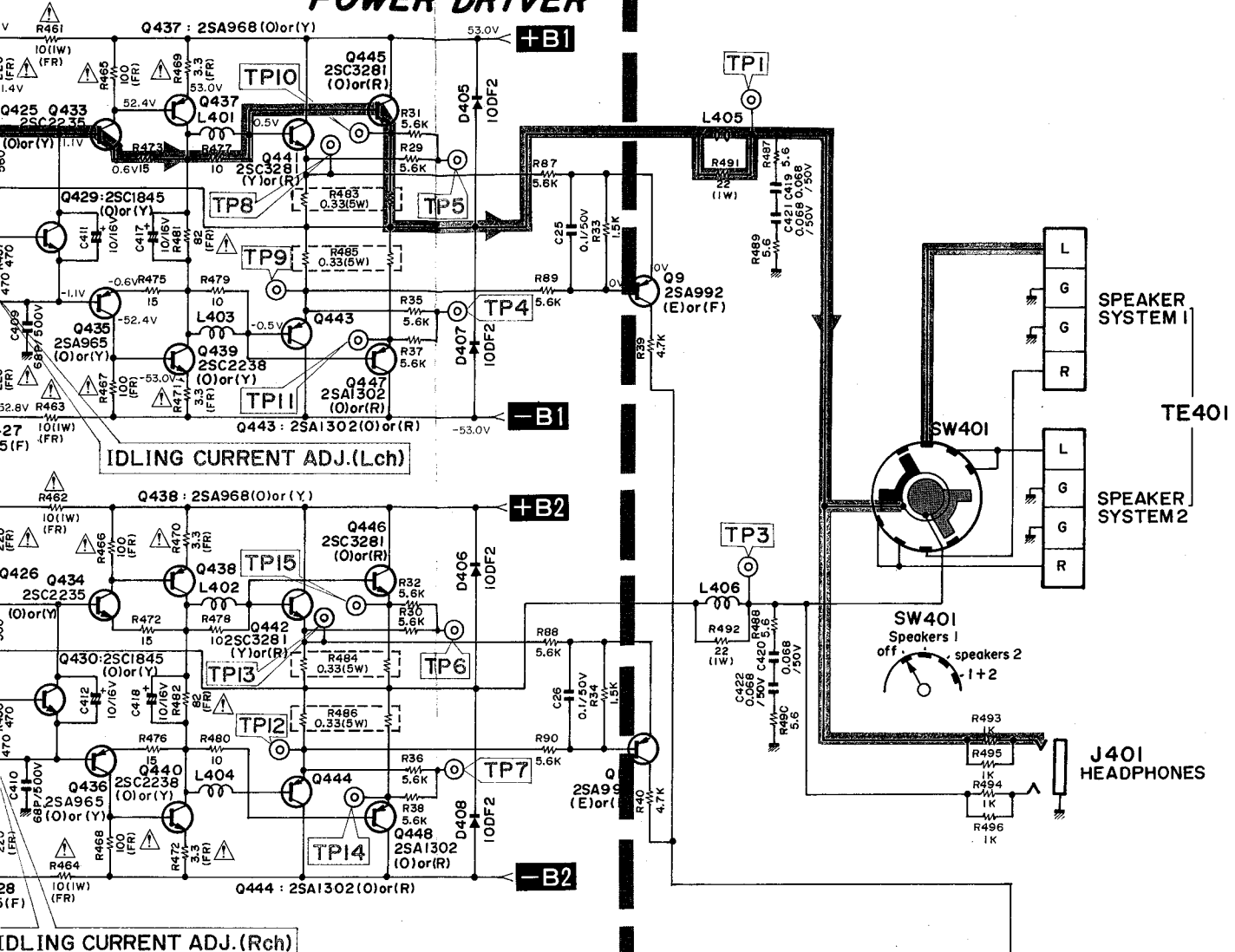

5

6

7

8

9

10

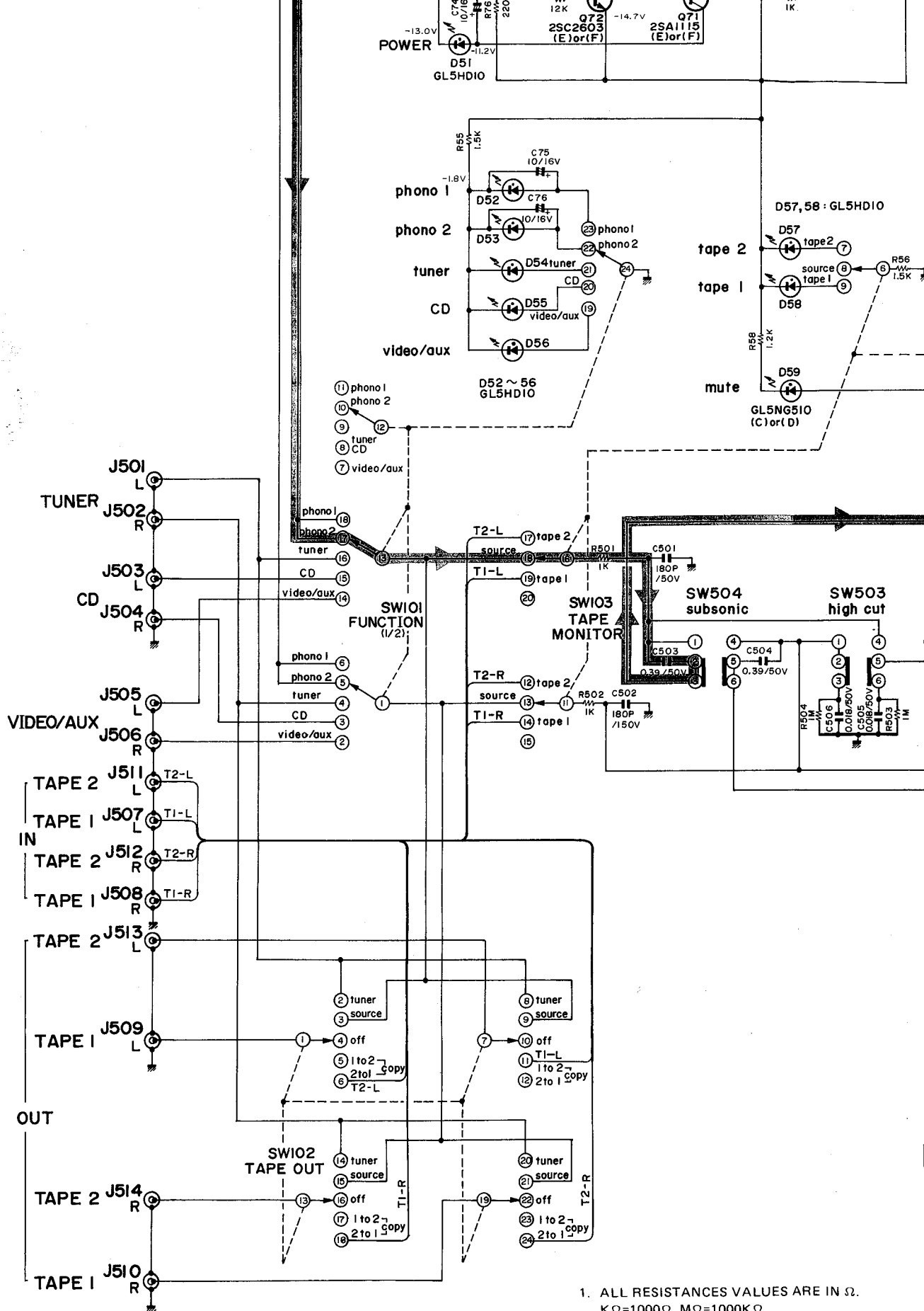

1. ALL RESISTANCES VALUES ARE IN Ω .
K Ω =1000 Ω , M Ω =1000K Ω .
2. THE WATTAGE OF RESISTORS IS 1/4W UNLESS OTHERWISE SPECIFIED.
3. ALL CAPACITANCES VALUES ARE IN μ F UNLESS OTHERWISE SPECIFIED.
4. ... V : DC VOLTAGE AT NO SIGNAL
5. SAFETY-REQUIREMENTS COMPONENTS IN THIS CIRCUIT. IN ACCORDANCE WITH SAFETY REGULATIONS, THESE COMPONENTS MUST BE REPLACED BY THE MANUFACTURER'S RECOMMENDED PARTS.

D57,58 : GL5HD10

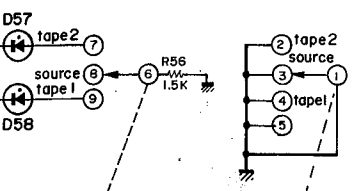

D59 : NG510 (D)

D59 : NG510 (D)

D59 : NG510 (D)

D59 : NG510 (D)

D59 : NG510 (D)

D59 : NG510 (D)

D59 : NG510 (D)

D59 : NG510 (D)

D59 : NG510 (D)

D59 : NG510 (D)

D59 : NG510 (D)

D59 : NG510 (D)

D59 : NG510 (D)

D59 : NG510 (D)

D59 : NG510 (D)

D59 : NG510 (D)

D59 : NG510 (D)

D59 : NG510 (D)

D59 : NG510 (D)

D59 : NG510 (D)

D59 : NG510 (D)

D59 : NG510 (D)

D59 : NG510 (D)

D59 : NG510 (D)

D59 : NG510 (D)

D59 : NG510 (D)

D59 : NG510 (D)

D59 : NG510 (D)

D59 : NG510 (D)

D59 : NG510 (D)

D59 : NG510 (D)

D59 : NG510 (D)

D59 : NG510 (D)

D59 : NG510 (D)

D59 : NG510 (D)

D59 : NG510 (D)

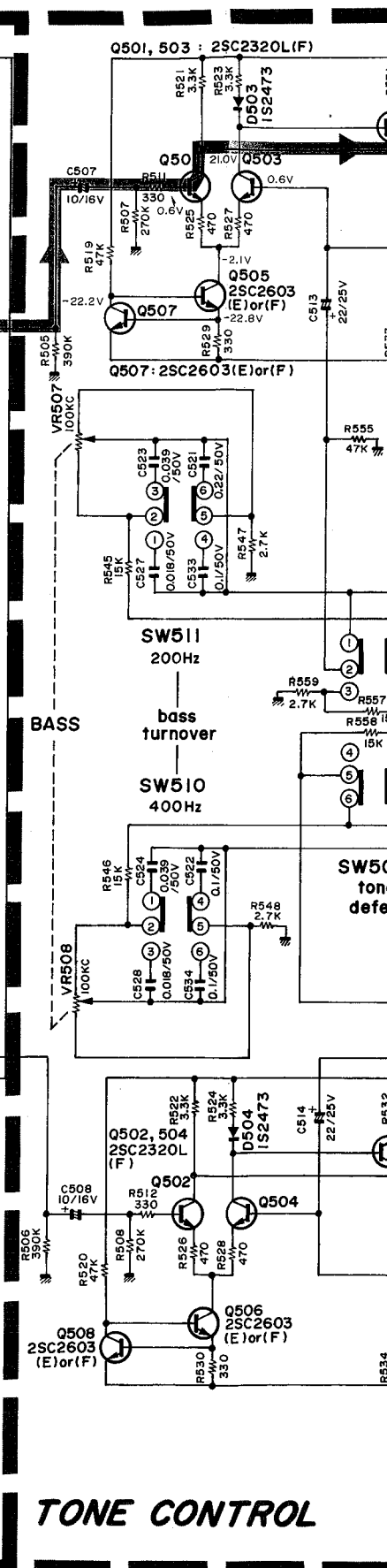
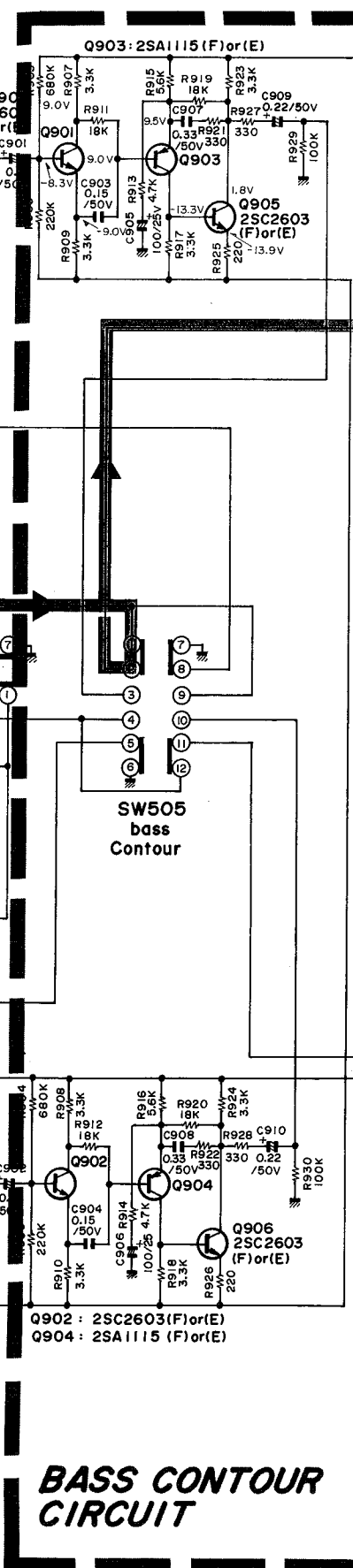

RESISTORS ARE IN Ω .

RESISTOR POWER IS 1/4W UNLESS OTHERWISE NOTED.

RESISTOR VALUES ARE IN μF UNLESS OTHERWISE NOTED. P= μF

RESISTOR VALUES ARE IN μF UNLESS OTHERWISE NOTED.

RESISTOR VALUES ARE IN μF UNLESS OTHERWISE NOTED.

RESISTOR VALUES ARE IN μF UNLESS OTHERWISE NOTED.

BASS CONTOUR CIRCUIT

TONE CONTROL

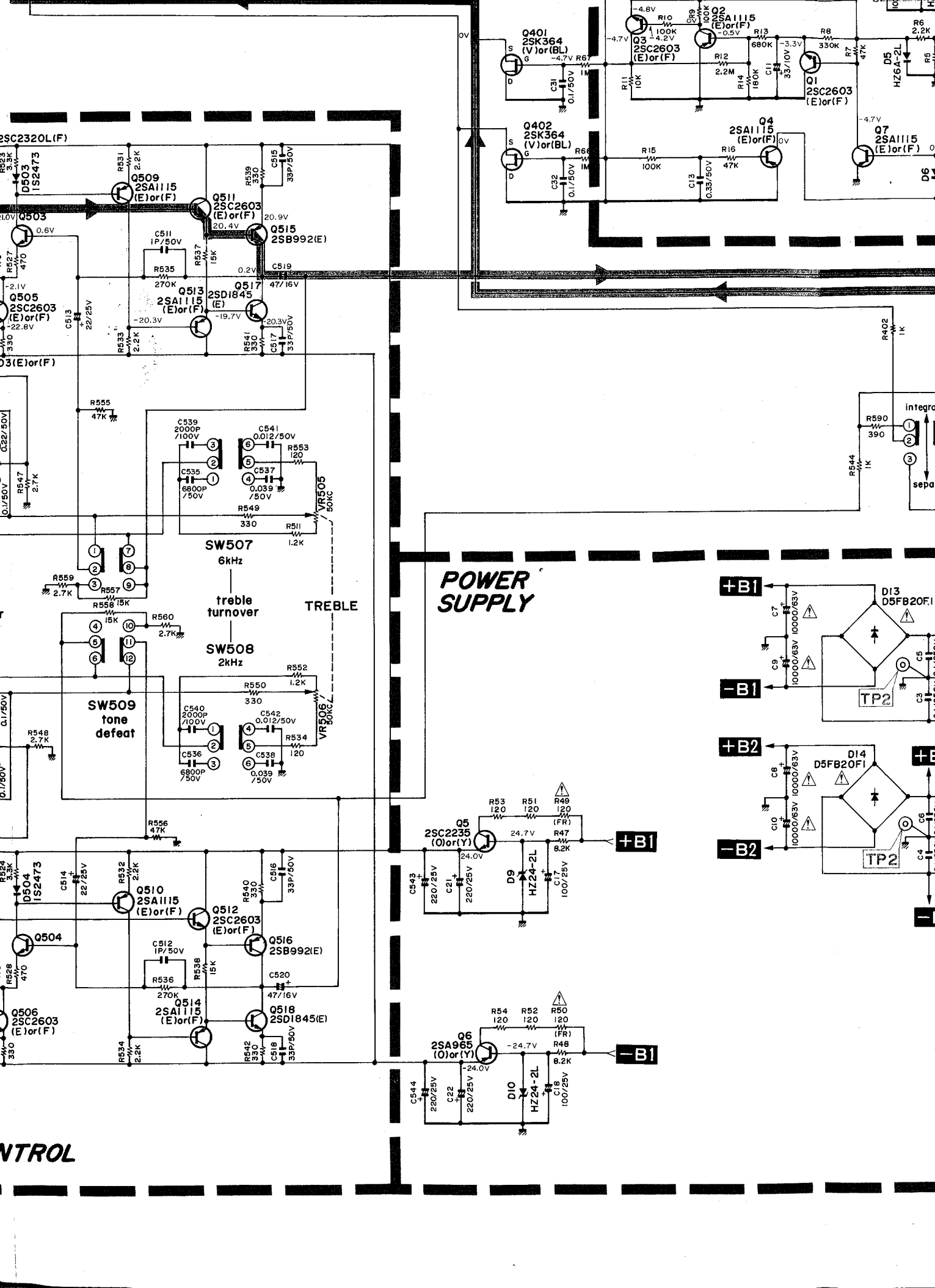

CONTROL

POWER SUPPLY

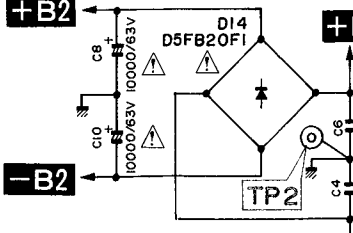
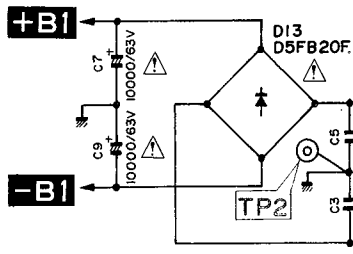

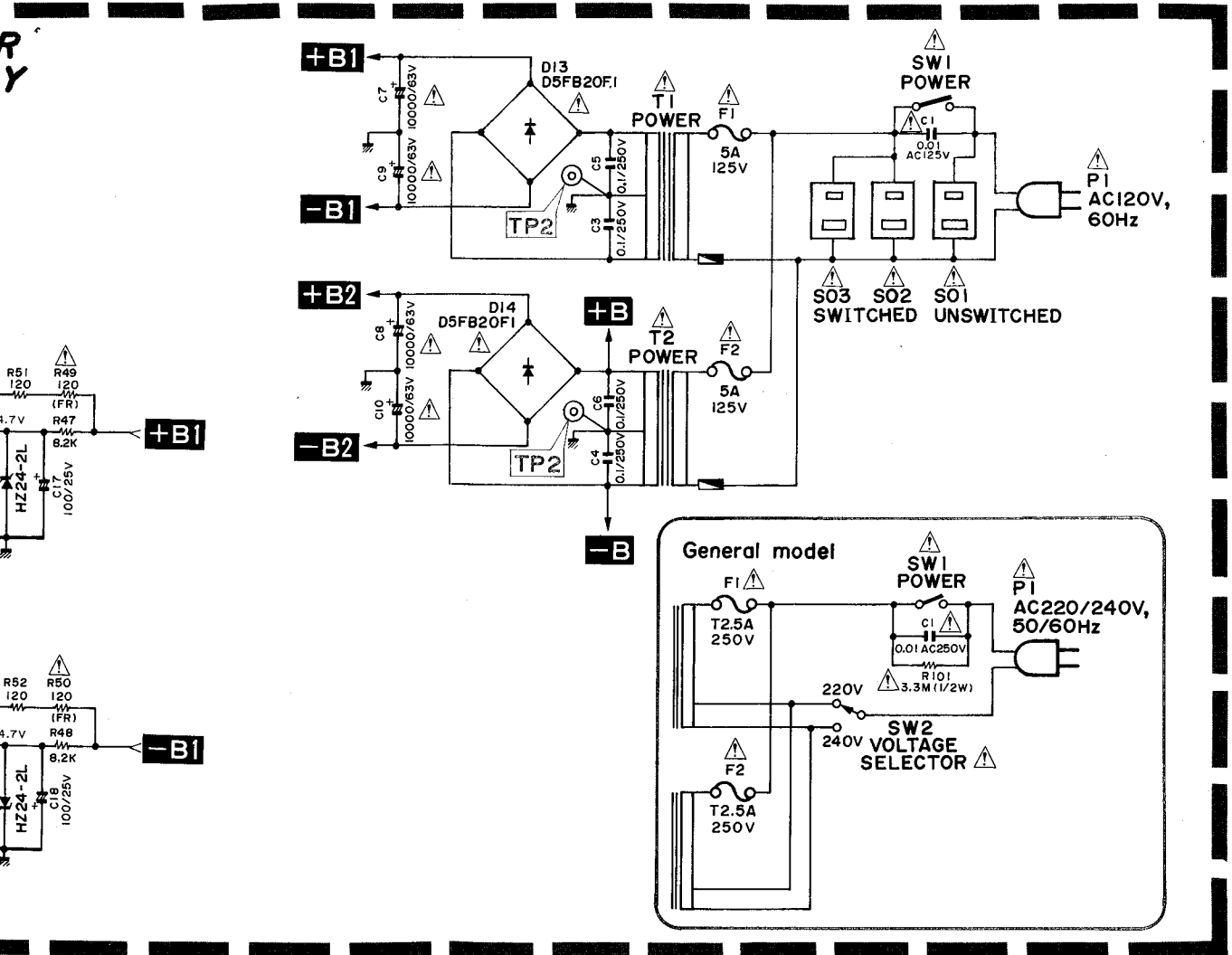
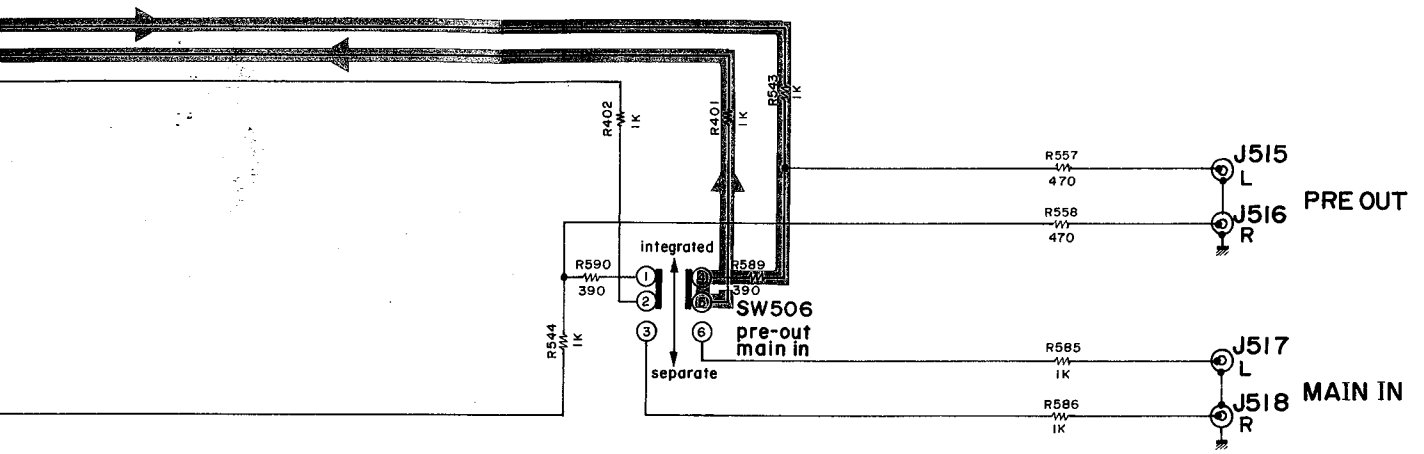
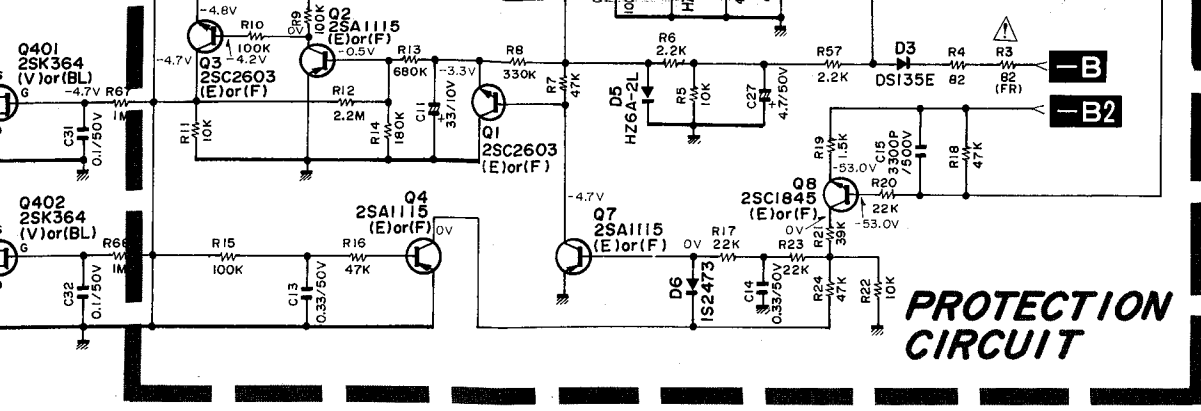

WIRING DIAGRAM

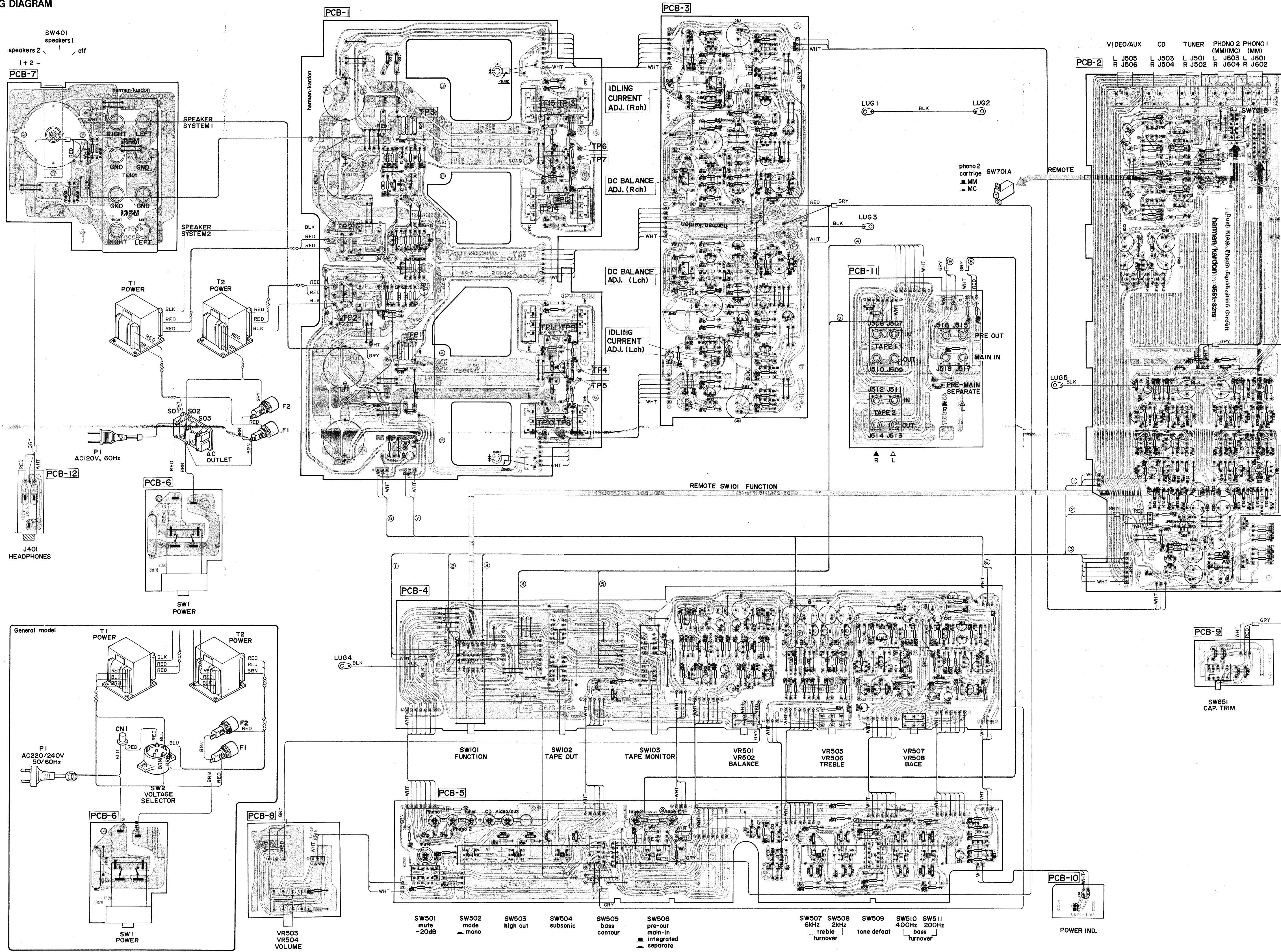

PIN CONNECTION DIAGRAM OF TRANSISTORS AND DIODES

2SC1845 2SA992 2SC2240 2SA999L 2SC2320L 2SA1190 2SC2855 2SB992 2SD1845	2SC2603 2SA1115	2SA965 2SC2235 2SB646 2SA965 2SD666 2SD667 2SB647 2SA1145 2SA1285 2SC3245	2SA968 2SC2238	2SC3281 2SA1302	2SD669 2SB649	2SK373 2SK363	2SK364	DS135E	HZ6A-2L 1S2473 HZ15-2L 10DF2 HZ24-2L	MV12YM	GLEHD10 GLENG510	D5FB20F1	MV103

● WIRE COLOR ABBREVIATIONS
 RED : Red
 ORG : Orange
 BLU : Blue
 WHT : White
 GRN : Green
 BLK : Black
 YEL : Yellow
 PUR : Purple
 PUK : Pink

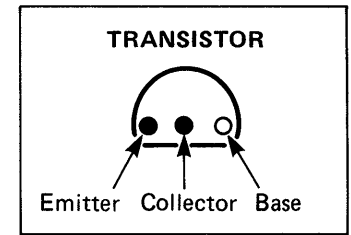

WIRING DIAGRAM

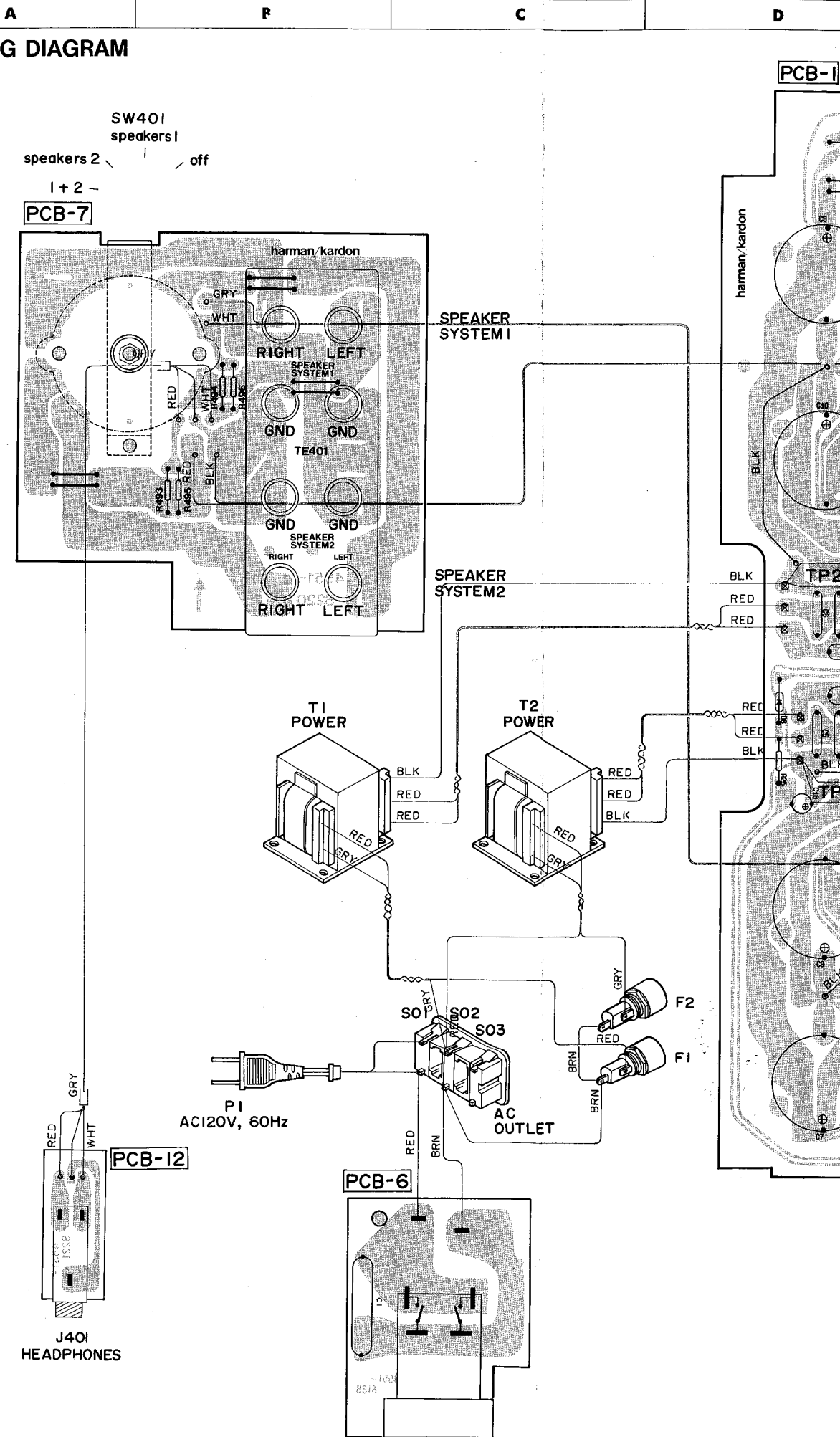

PCB-1

PCB-3

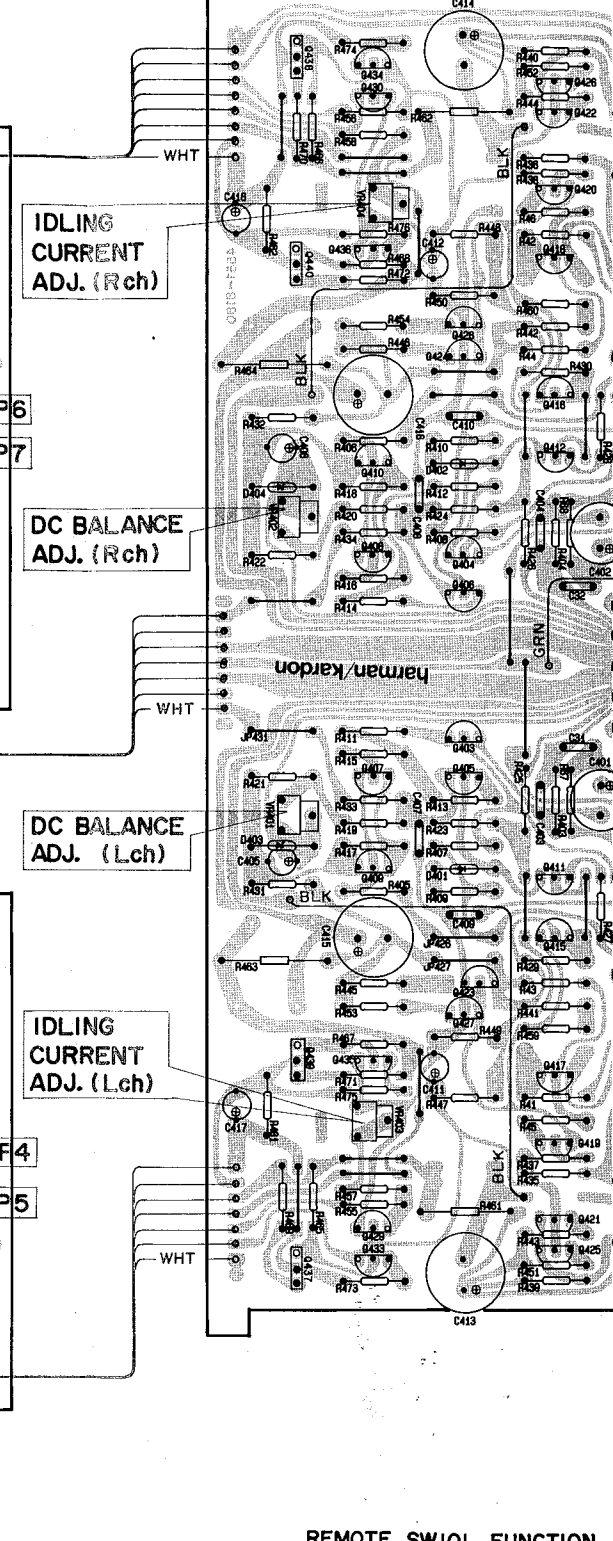
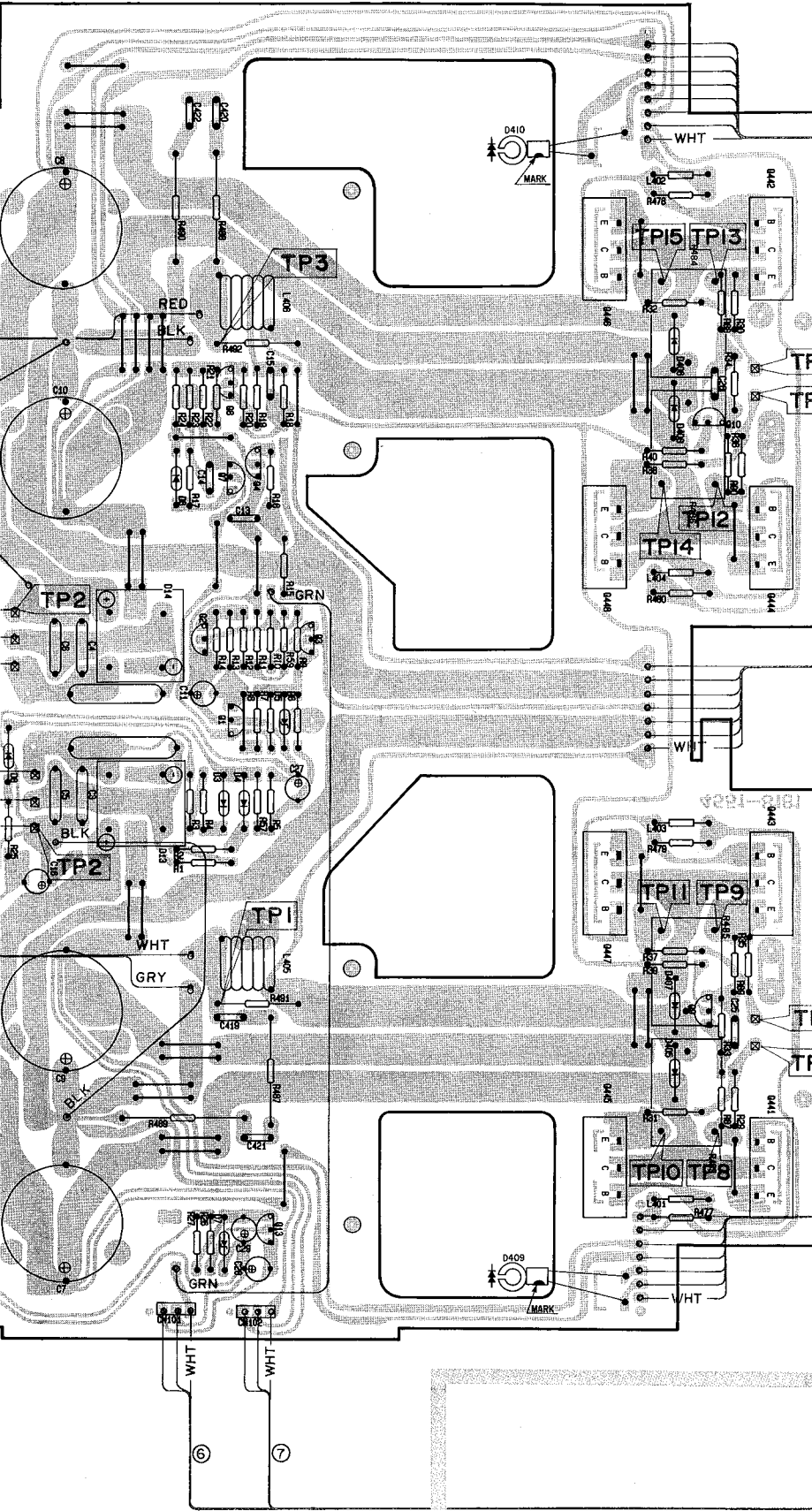

REMOTE SWI0I FUNCTION

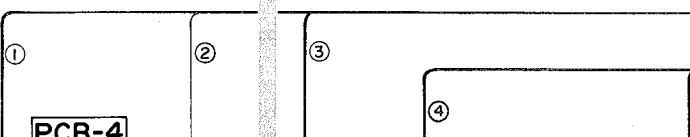

PCB-4

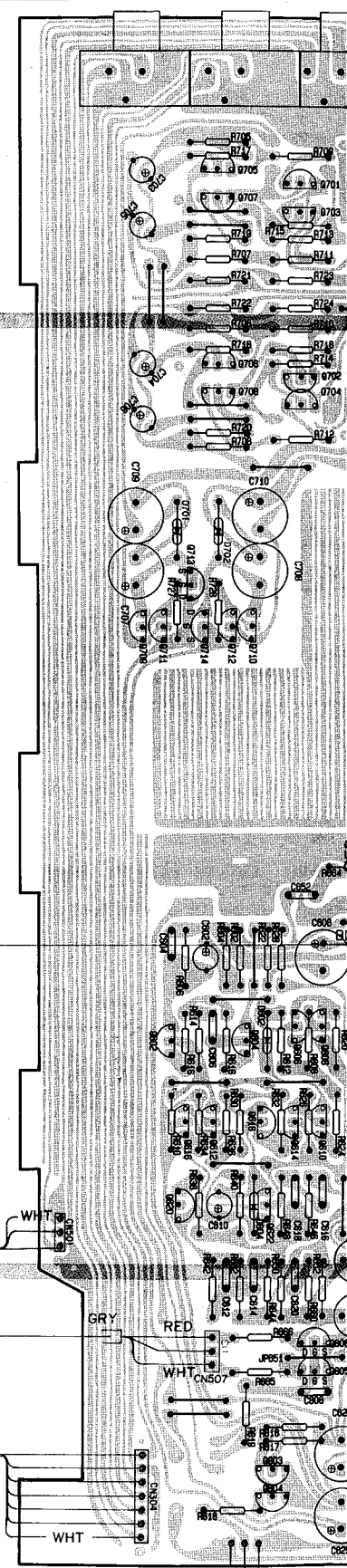
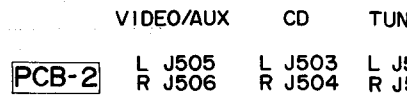
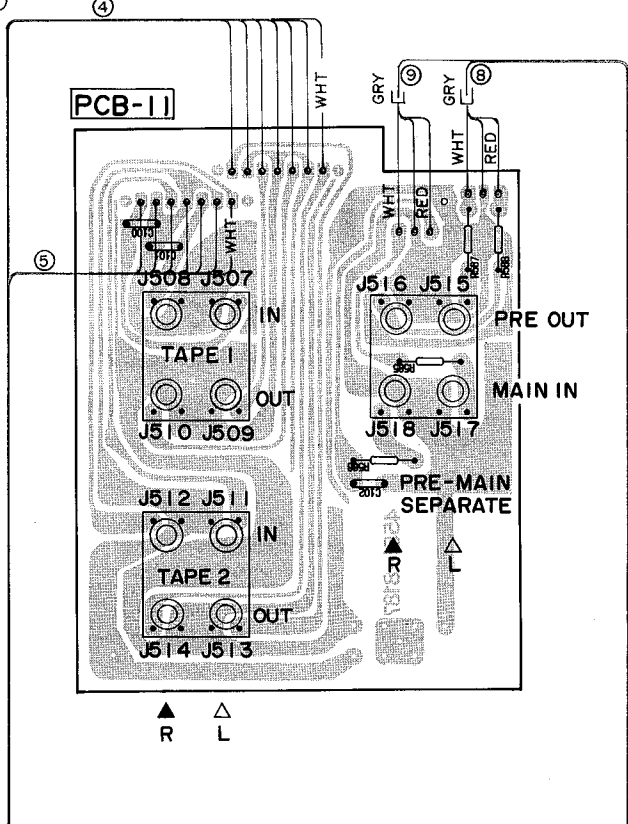
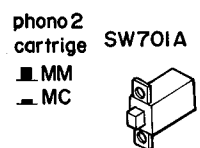
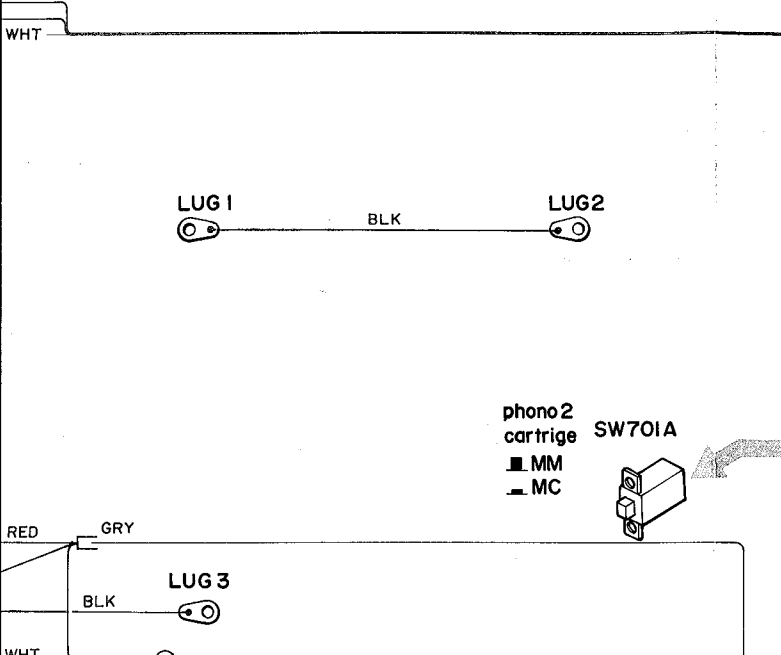
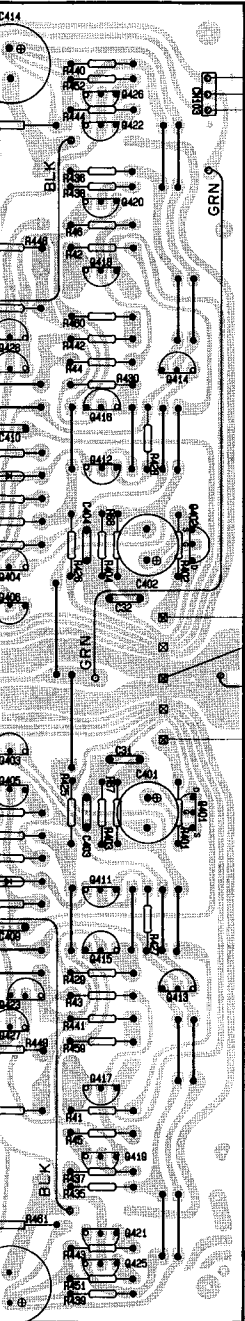

REMOTE

LUG 5 BLK

DI FUNCTION

- ①
- ②
- ③

⑥

VIDEO/AUX CD TUNER PHONO 2 PHONO 1
 (MM)(MC) (MM)

PCB-2 L J505 L J503 L J501 L J603 L J601
 R J506 R J504 R J502 R J604 R J602

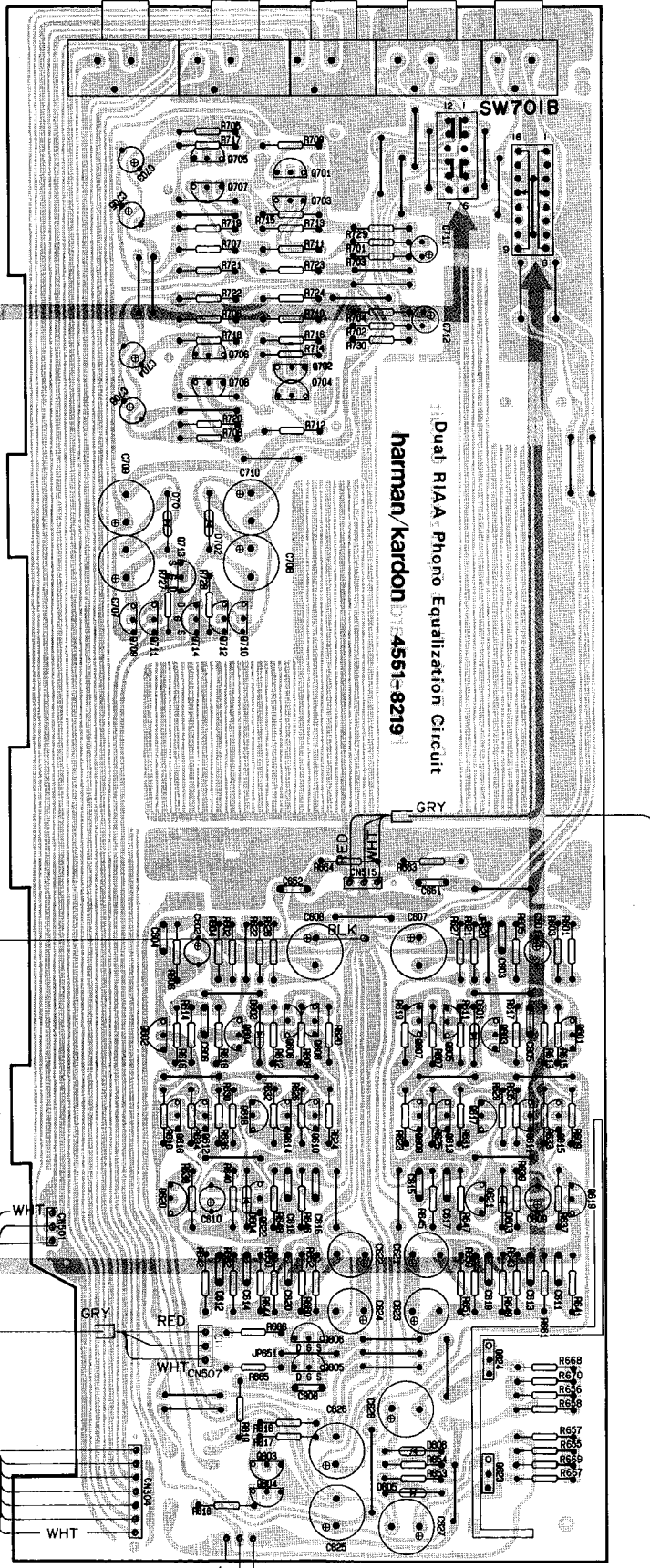
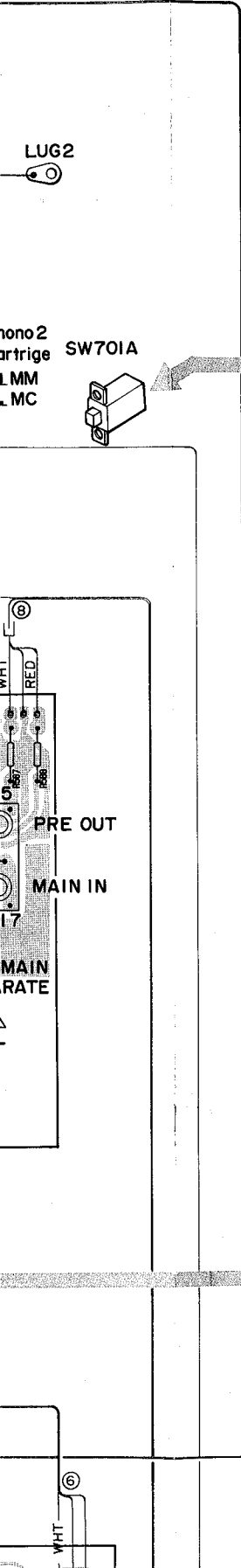

5

6

7

8

9

10

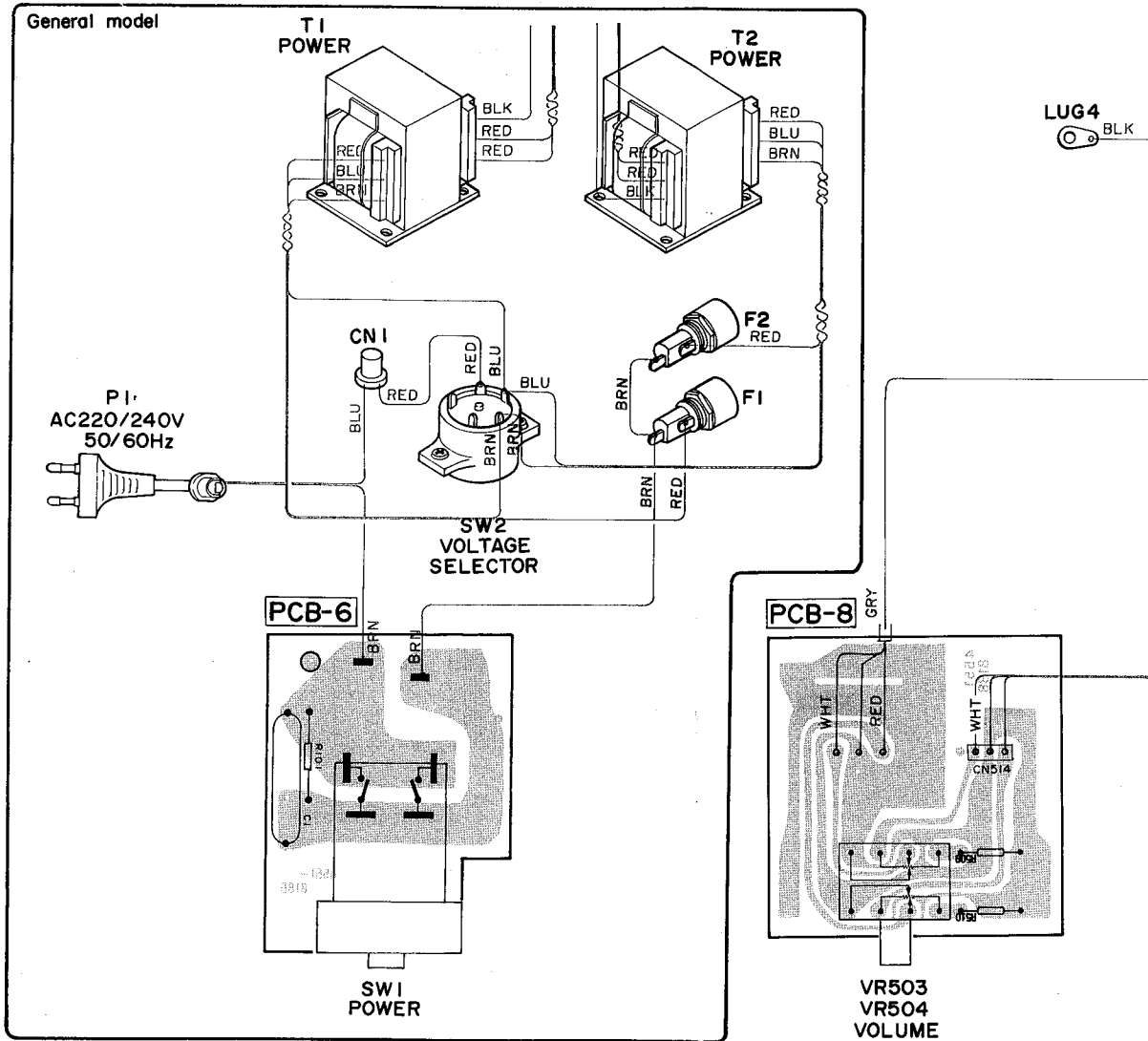
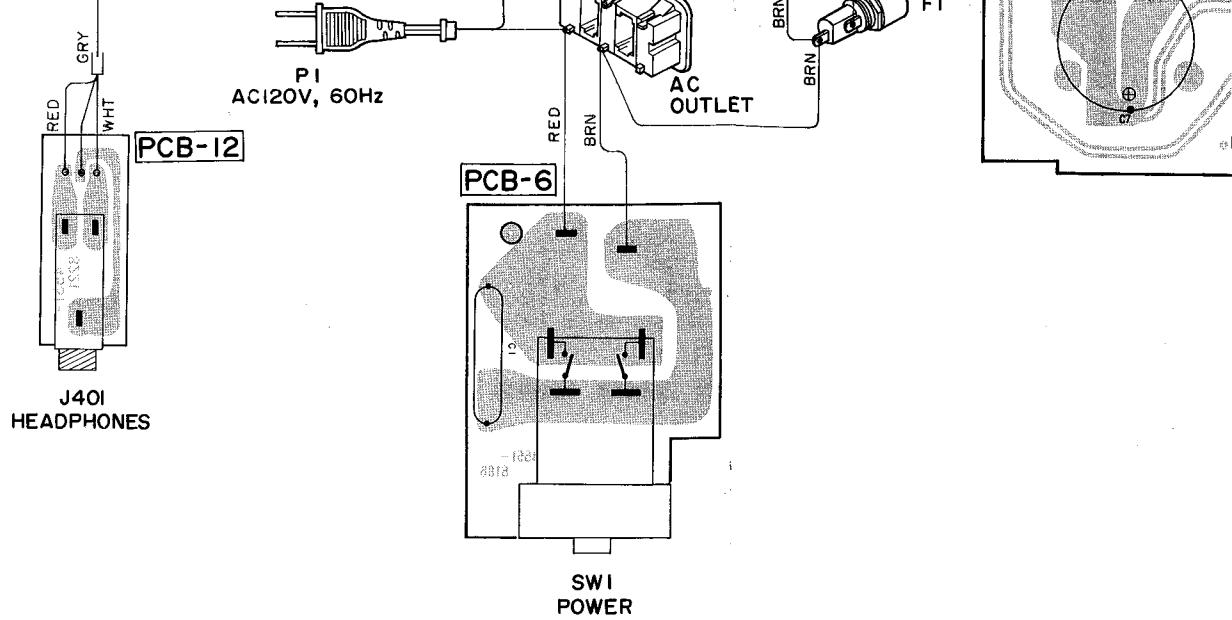

PIN CONNECTION DIAGRAM OF TRANSIS

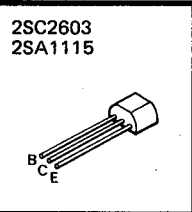
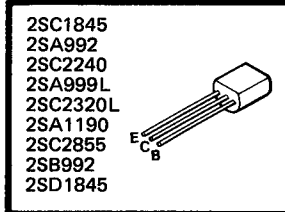

REMOTE SWIOI FUNCTION

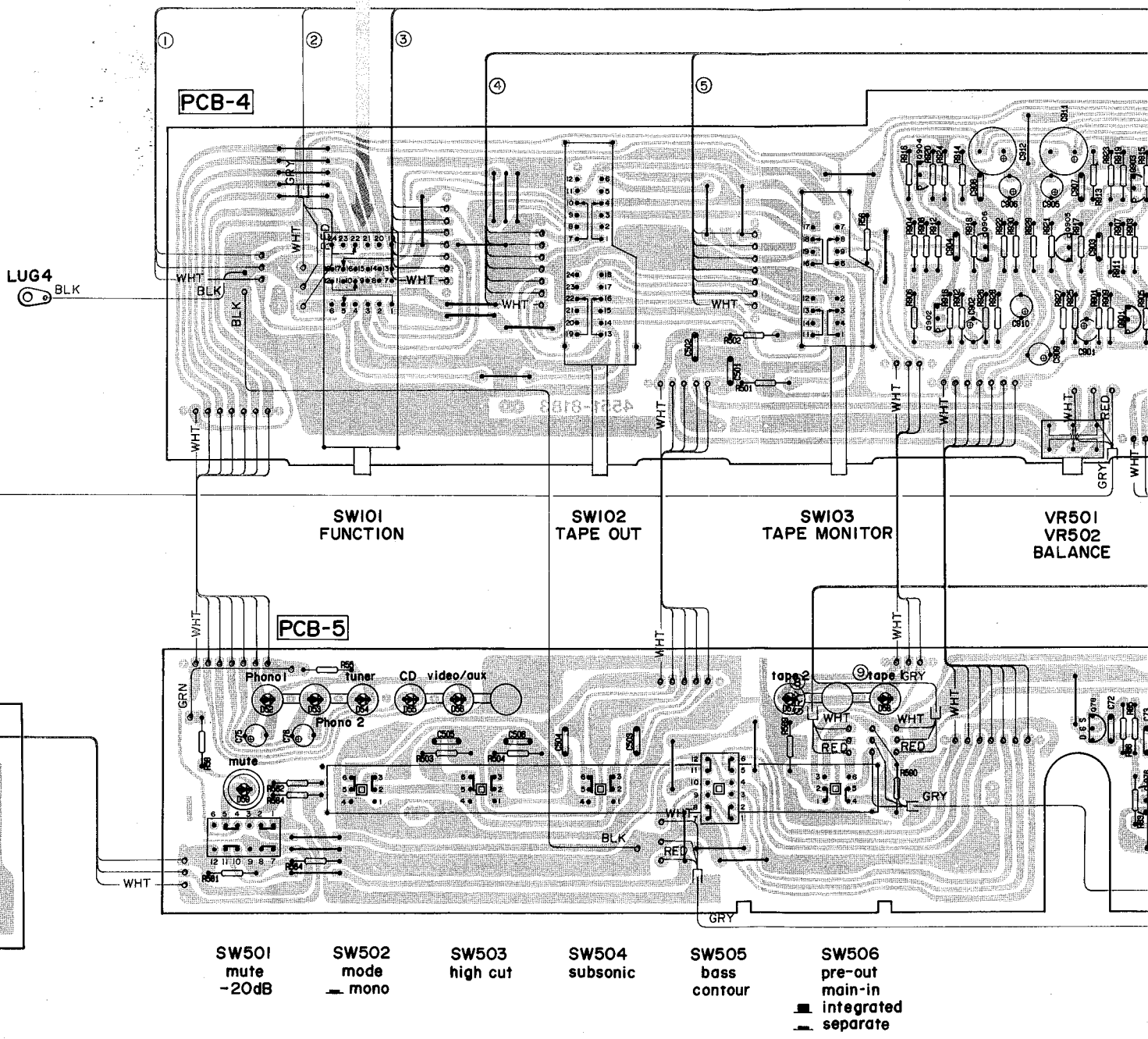

GRAM OF TRANSISTORS AND DIODES

2SC2603
2SA1115

2SA965 2SC2235
2SB646 2SA965
2SD666
2SD667
2SB647
2SA1145
2SA1285
2SC3245

2SA968
2SC2238

2SC3281
2SA1302

2SD669
2SB649

2SK373
2SK363

2SK364

DS135E

J514 J513

▲
R
△
L

REMOTE SW/OI FUNCTION

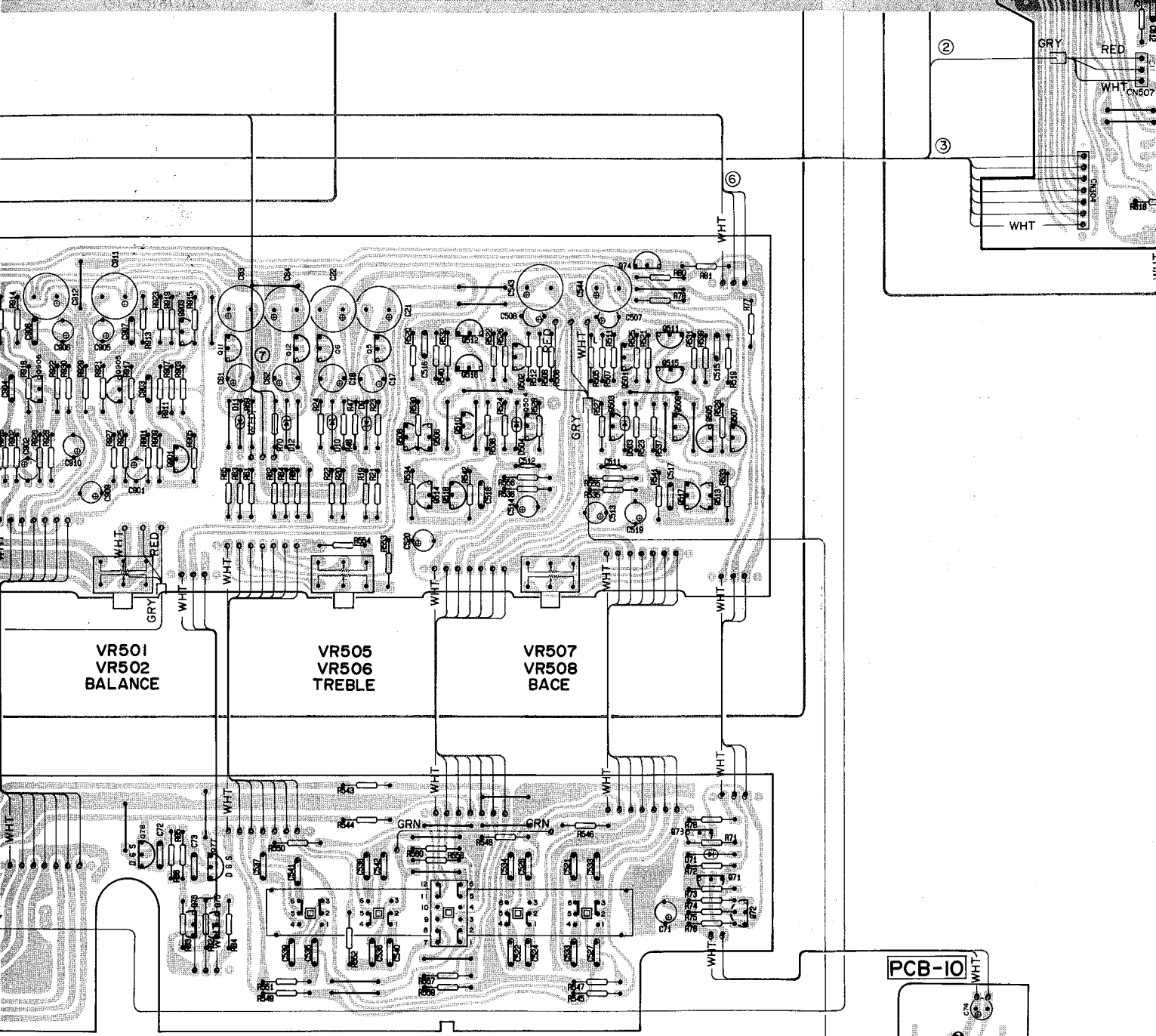

SW507 SW508 6kHz 2kHz
treble turnover

SW509 tone defeat

SW510 SW511 400Hz 200Hz
bass turnover

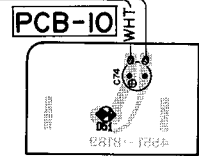

POWER IND.

<p>54</p>	<p>DS135E</p>	<p>HZ6A-2L 1S2473 HZ15-2L 10DF2 HZ24-2L</p> <p>DIODE</p>	<p>MV12YM</p> <p>MARK</p>	<p>GL5HD10 GL5NG510</p> <p>Cathode Anode</p>	<p>D5FB20F1</p>	<p>MV103</p> <p>Anode Cathode</p>
-----------	---------------	--------------------------------------------------------------------------	---------------------------	--------------------------------------------------	-----------------	-----------------------------------

- WIRE COLOR AB
- RED : Red
 - ORG : Orange
 - BLU : Blue
 - WHT : White
 - GRN : Green
 - BLK : Black
 - YEL : Yellow
 - PUP : Purple
 - PIK : Pink

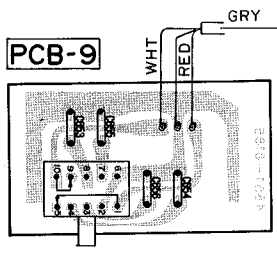
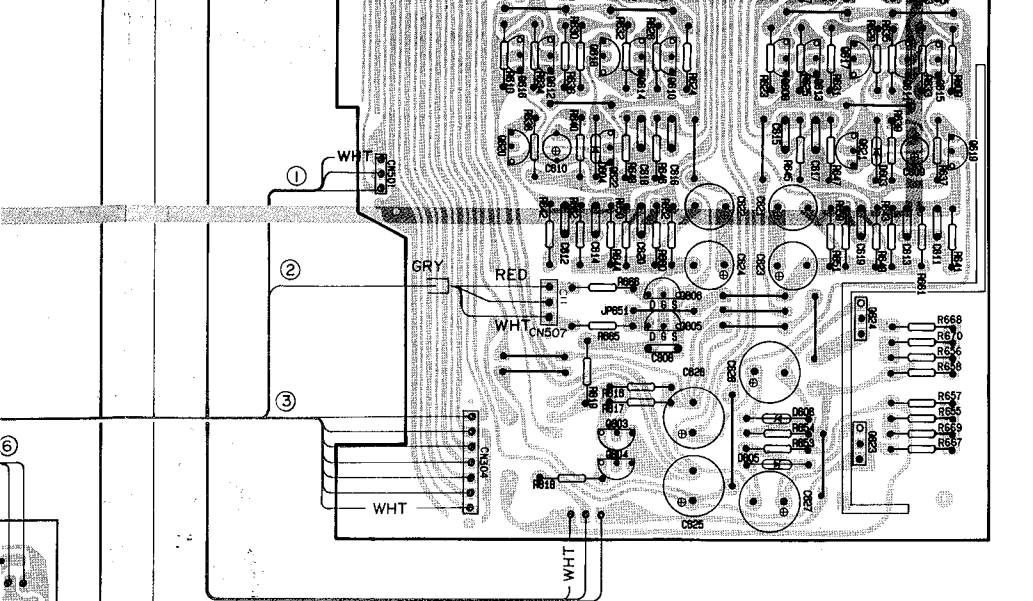

SW651
CAP. TRIM

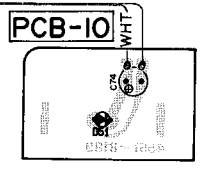

POWER IND.

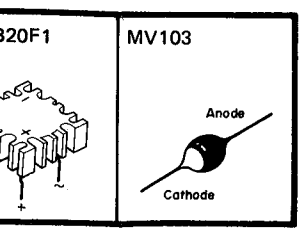

- WIRE COLOR ABBREVIATIONS
- RED : Red
 - ORG : Orange
 - BLU : Blue
 - WHT : White
 - GRN : Green
 - BLK : Black
 - YEL : Yellow
 - PUP : Purple
 - PIK : Pink

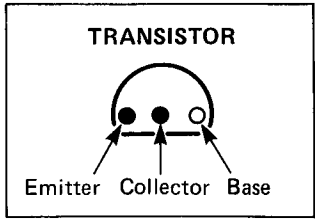

SCHEMATIC DIAGRAM (only German model)

For the German model, the circuit is partially modified as shown below. As the rest of the circuit remains the same as the General model circuit, refer to the schematic diagram on page 12.

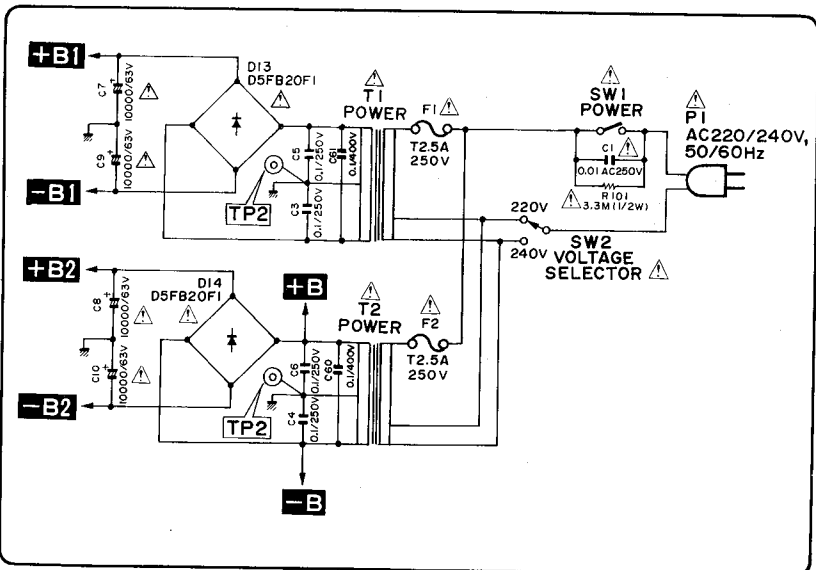
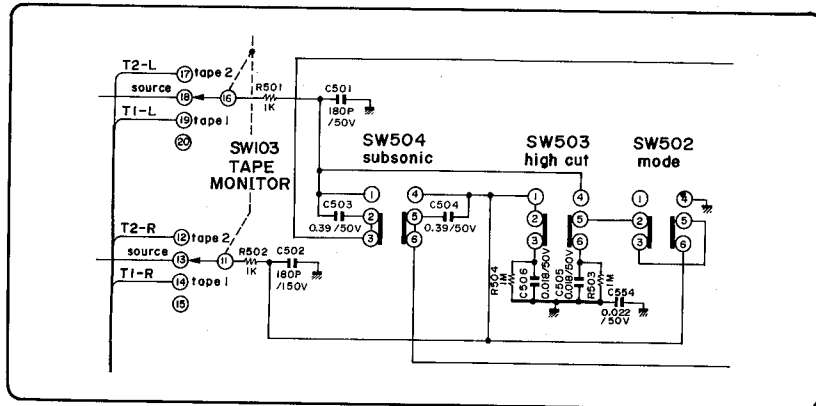
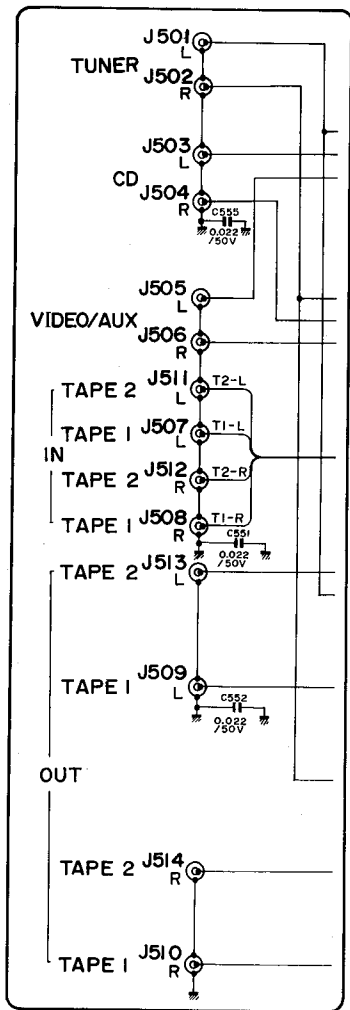
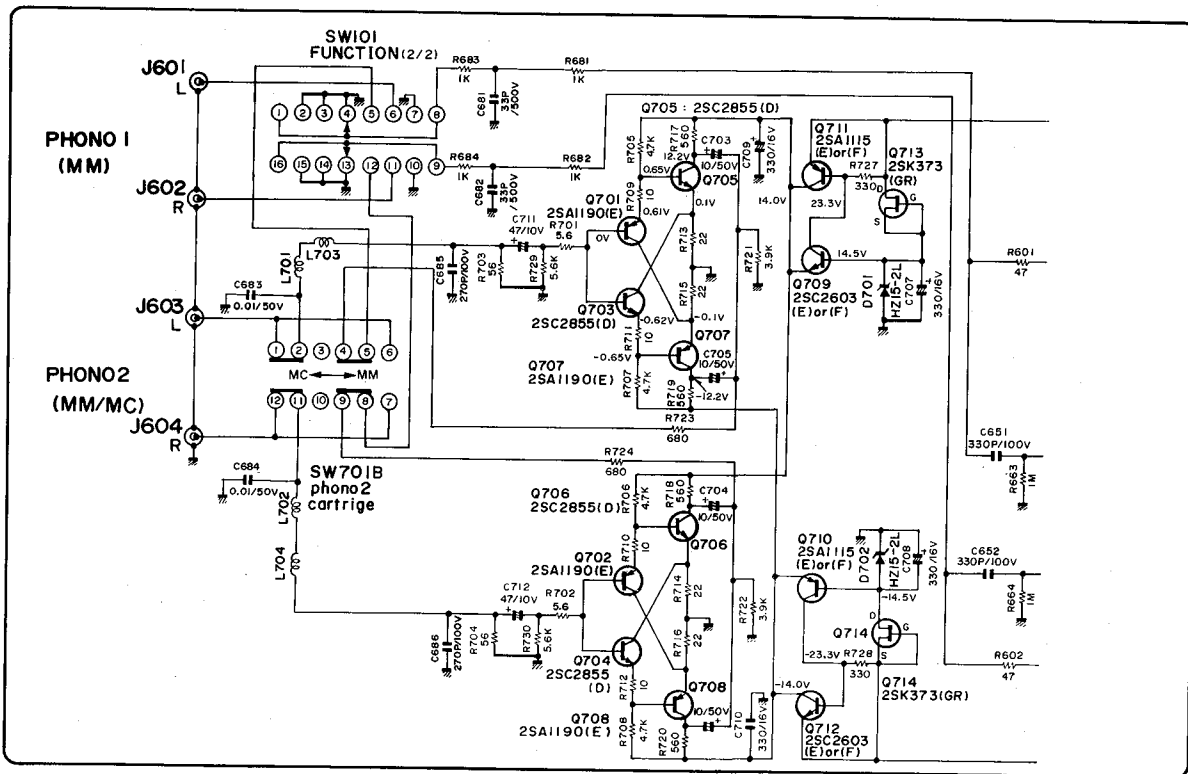

WIRING DIAGRAM (only German model)

For the German model, the circuit is partially modified as shown below. As the rest of the circuit remains the same as the General model circuit, refer to the wiring diagram on page 13.

