

# The Harman Kardon Model HK640/HK660 INTEGRATED AMPLIFIER

Manual 198A

## Technical Manual

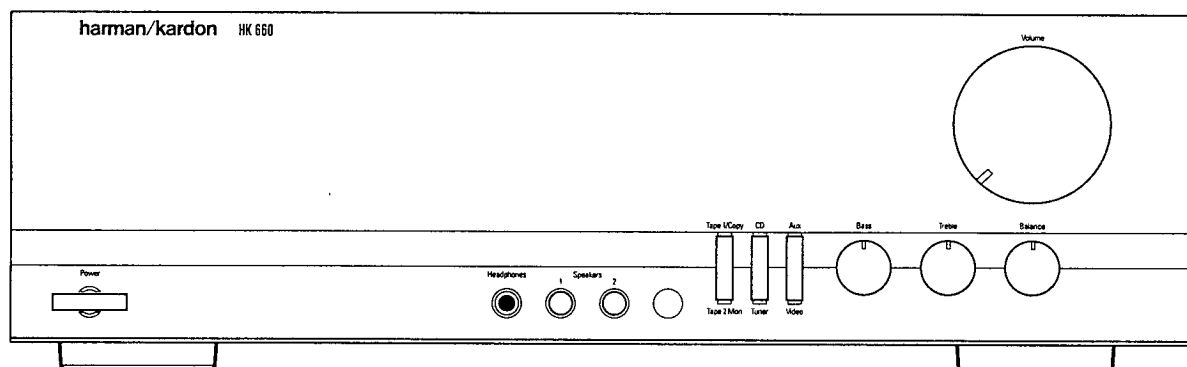

The following marks found in the parts list of this manual identify the models as follows:

HK640/HK660 **IB** : International model Black version

HK640/HK660 **I** : International model

HK640 **WB** : Asia/Oceania model Black version

### CONTENTS

SPECIFICATIONS .....	2	IC BLOCK DIAGRAM .....	14
DISASSEMBLY PROCEDURES .....	2	WIRING DIAGRAM .....	15
CONTROLS AND FUNCTIONS .....	3	SCHEMATIC DIAGRAM .....	15
POWER CORD REPLACEMENT .....	3	<b>PH600 PHONO P.C. BOARD OPTION</b>	
ALIGNMENT PROCEDURES .....	3	HOW TO INSTALL .....	19
BLOCK DIAGRAM .....	3	GENERAL UNIT PARTS LIST .....	19
GENERAL UNIT EXPLODED VIEW .....	4	P.C. BOARD .....	20
GENERAL UNIT PARTS LIST .....	5	WIRING DIAGRAM .....	20
P.C. BOARDS .....	5	SCHEMATIC DIAGRAM .....	21
ELECTRICAL PARTS LIST .....	7	ELECTRICAL PARTS LIST .....	22
IC TERMINAL FUNCTION .....	13		

**harman/kardon**

Parts and Service Office  
80 Crossways Park West, Woodbury, N.Y. 11797  
1112-HK640-A A9502 300 Printed in Japan



# CONTROLS AND FUNCTIONS

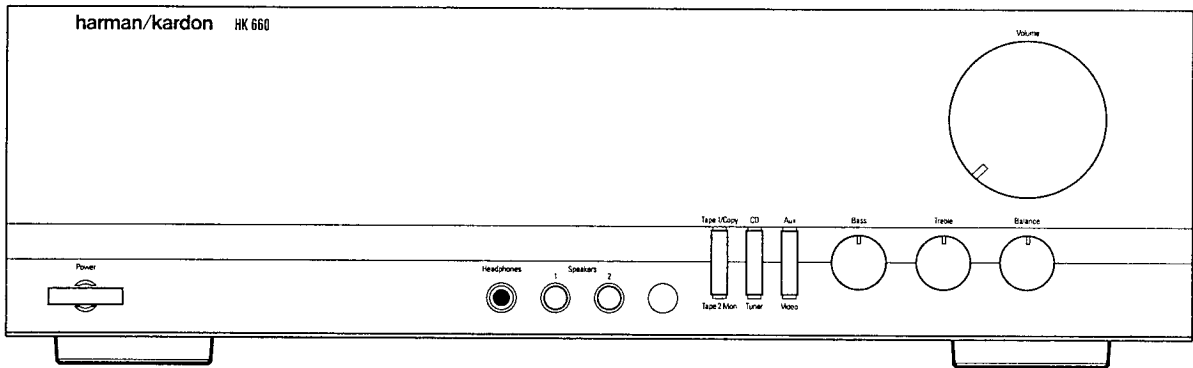

### Power Switch

Press to turn the unit on and off.

### Headphone Jack

Plug in headphones if desired. (With both Speakers 1 and 2 switches in Off position, output is supplied only to headphones.)

### Speakers Switches

Push in to select either of two sets of speakers, or both, or neither (headphone output only).

### Function Selector Buttons

Select desired input source by pressing the corresponding button.

### Bass Control

Turn to increase or decrease the proportion of low frequency sound.

### Treble Control

Turn to increase or decrease the proportion of high frequency sound.

### Balance Control

Turn to adjust relative output level of left and right speakers.

### Volume Control

Turn to raise or lower output volume.

## POWER CORD REPLACEMENT

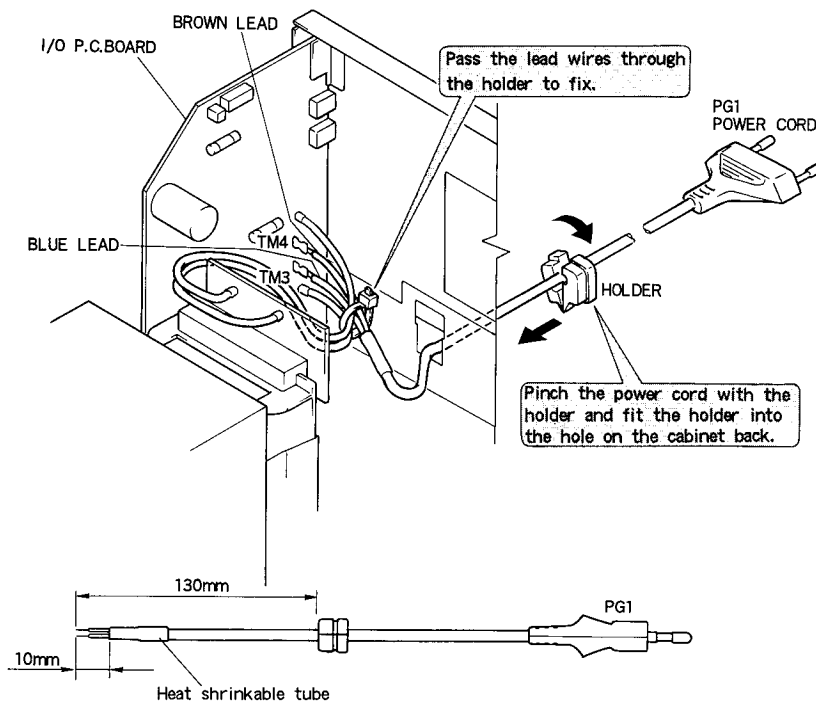

## ALIGNMENT PROCEDURES (REFER TO PAGES 6,7AND18)

- **Conditions :**
- Set the Function selector to the "CD" position.
  - Set the Volume control to minimum.
  - Make the adjustment at a room temperature of 77°F (25°C).

### ■ DC BALANCE CONFIRMATION

Step	Connection Equipments	Adjustment	For
1	Connect the Digital Volt Meter to Speaker output (L ch).		$0 \pm 60\text{mV}$
2	Connect the Digital Volt Meter to Speaker output (R ch).		$0 \pm 60\text{mV}$

### ■ IDLING CURRENT ADJUSTMENT

Step	Connection Equipments	Adjustment	For
1	Connect the Digital Volt Meter to TP401 and TP403.	VR401	$33\text{mV} \pm 2\text{mV}$
2	Connect the Digital Volt Meter to TP402 and TP404.	VR402	$33\text{mV} \pm 2\text{mV}$

- After the above adjustment, leave the unit with its power on for longer than 15 minutes and then repeat the same adjustment.

## BLOCK DIAGRAM

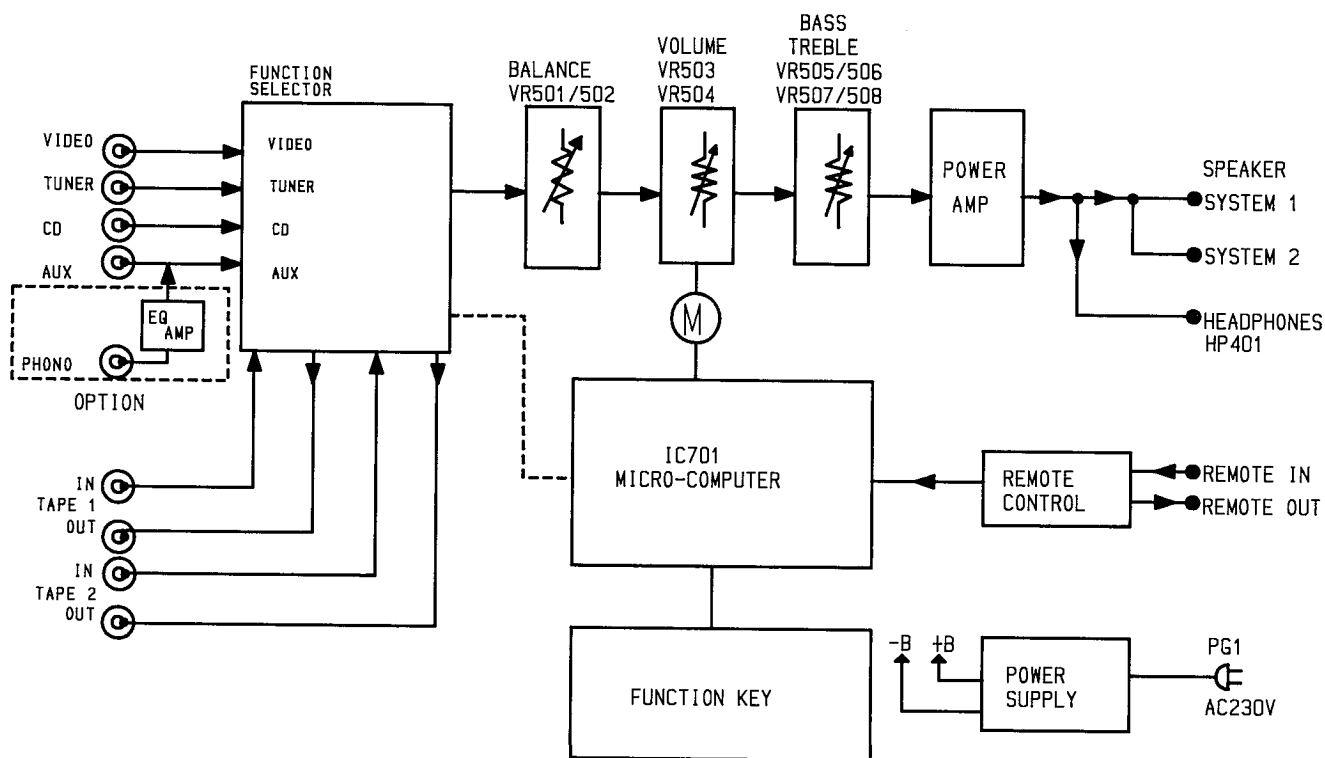



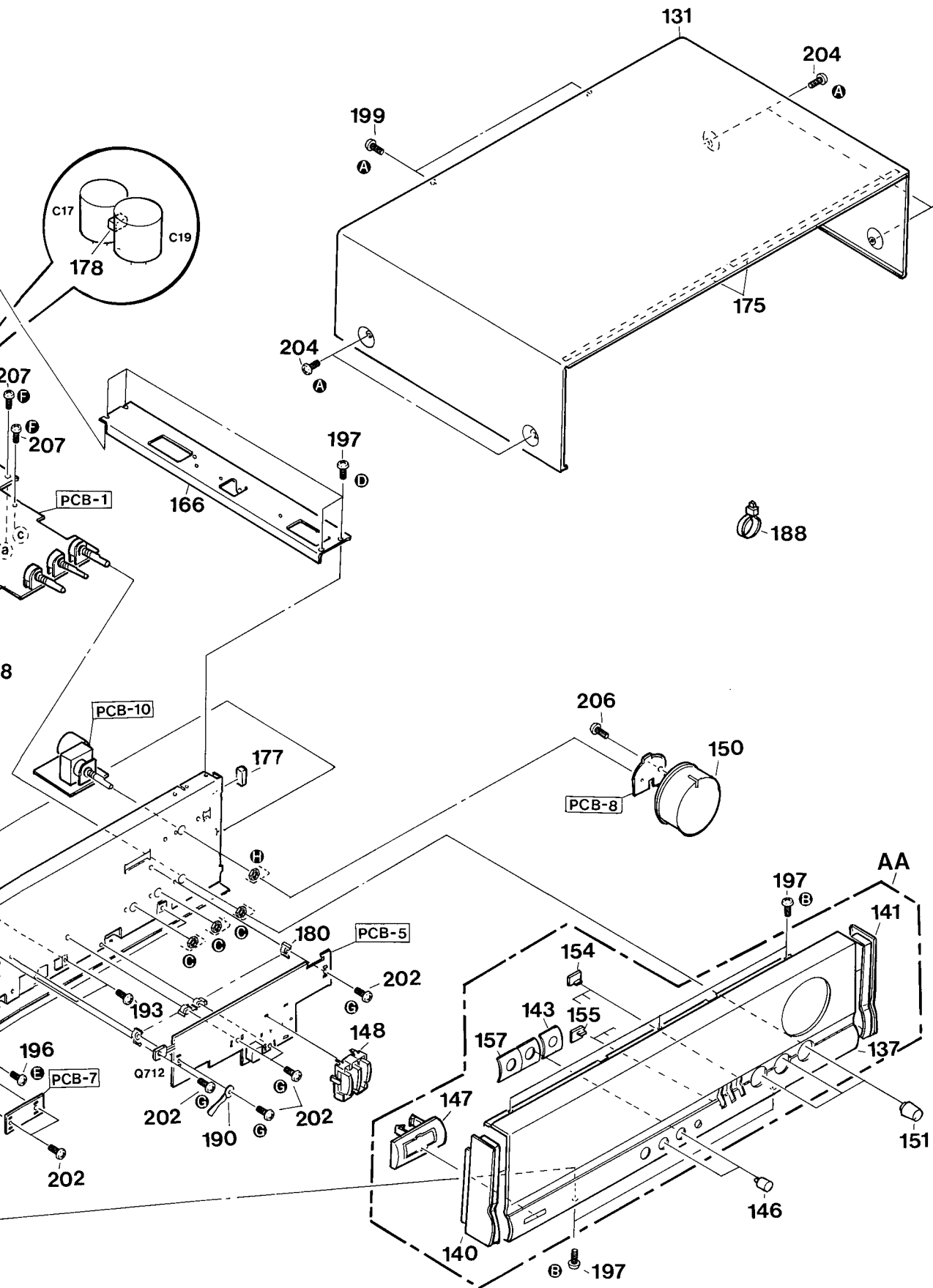

## GENERAL UNIT PARTS LIST

Ref. No.	Part No.	Description	Ref. No.	Part No.	Description
AA	A443-HK6440A	FRONT PANEL ASSEMBLY (Model: HK640) <b>IB</b> <b>WB</b>	176	2224-7134	INSULATOR, POWER Tr (x4) (Model: HK640)
AA	A443-HK6440B	FRONT PANEL ASSEMBLY (Model: HK640) <b>I</b>	176	2224-7148	INSULATOR, POWER Tr (x4) (Model: HK660)
AA	A443-HK6660A	FRONT PANEL ASSEMBLY (Model: HK660) <b>IB</b>	177	2112-11809	SPONGE, CHASSIS SIDE (x2)
AA	A443-HK6660B	FRONT PANEL ASSEMBLY (Model: HK660) <b>I</b>	178	2112-11806	SPONGE, MAIN PCB C17, C19
AB	A319-HK6440A	LEG ASSEMBLY	179	2360-7017	BOSS, SPE, PCB (x4)
131	1414-17601	CABINET TOP	180	2360-7026	BOSS, SPE (x6)
133	1424-38201	CABINET BACK, BOTTOM	182	1756-R01TL101	LABEL, FUSE LABEL (Model: HK660)
135	1424-38301	CABINET BACK, REAR (Model: HK640) <b>IB</b> <b>I</b>	184	2402-0374	WASHER, PLASTIC (x2) (Model: HK640)
135	1424-38302	CABINET BACK, REAR (Model: HK640) <b>WB</b>	184	2402-0374	WASHER, PLASTIC (x3) (Model: HK660)
135	1424-38401	CABINET BACK, REAR (Model: HK660)	185	2459-3003511	RIVET, PLASTIC
137	1443-15001	FRONT PANEL (Model: HK640) <b>IB</b> <b>WB</b>	187	2240-364	HOLDER, AC CORD
137	1443-15002	FRONT PANEL (Model: HK640) <b>I</b>	188	2240-R0101	HOLDER, WIRING (x18)
137	1443-15003	FRONT PANEL (Model: HK660) <b>IB</b>	189	2218-7011	BRACKET, FIX (Model: HK660)
137	1443-15004	FRONT PANEL (Model: HK660) <b>I</b>	190	2218-R0130	BRACKET, FIX (x2)
140	1562-09602	FRAME, L (Model: HK640) <b>IB</b> <b>WB</b> (Model: HK660) <b>IB</b>	191	2459-3004511	RIVET, PLASTIC (x8)
140	1562-09601	FRAME, L (Model: HK640/660) <b>I</b>	193	2327-R0130062	SCREW, BND+ (3x6 mm) (x2)
141	1562-09702	FRAME, R (Model: HK640) <b>IB</b> <b>WB</b> (Model: HK660) <b>IB</b>	196	2347-R0130062	SCREW, BND T+ (3x6 mm) (x11)
141	1562-09701	FRAME, R (Model: HK640/660) <b>I</b>	197	2347-R0130062	SCREW, BND T+ (3x6 mm) (x10)
143	1532-22801	WINDOW, REMOTE SENSOR	198	2347-R0130062	SCREW, BND T+ (3x6 mm) (x7)
144	1511-23601	PLATE, EQ	199	2347-R0130084	SCREW, BND T+ (3x8 mm) (x19) (Model: HK640)
146	1662-67202	PUSH BUTTON, SPEAKERS (x2) (Model: HK640) <b>IB</b> <b>WB</b> (Model: HK660) <b>IB</b>	199	2347-R0130084	SCREW, BND T+ (3x8 mm) (x21) (Model: HK660)
146	1662-67201	PUSH BUTTON, SPEAKERS (x2) (Model: HK640/660) <b>I</b>	202	2347-R0130102	SCREW, BND T+ (3x10 mm) (x7)
147	1660-02302	PUSH BUTTON, POWER BUTTON/INDICATOR (Model: HK640) <b>IB</b> <b>WB</b> (Model: HK660) <b>IB</b>	203	2347-401027	SCREW, BND T+ (4x10 mm) (x4)
147	1660-02301	PUSH BUTTON, POWER BUTTON/INDICATOR (Model: HK640/660) <b>I</b>	204	2347-R0140064	SCREW, BND T+ (4x6 mm) (x4)
148	1662-71902	PUSH BUTTON, TAPE 1/COPY/TAPE 2 MON/CD/TUNER/AUX/VIDEO (Model: HK640) <b>IB</b> <b>WB</b> (Model: HK660) <b>IB</b>	206	2347-R0126082	SCREW, BND T+ (2.6x8 mm)
148	1662-71901	PUSH BUTTON, TAPE 1/COPY/TAPE 2 MON/CD/TUNER/AUX/VIDEO (Model: HK640/660) <b>I</b>	207	2347-R0130162	SCREW, BND T+ (3x16 mm) (x4)
150	1630-05002	ROTARY KNOB, VOLUME (Model: HK640) <b>IB</b> <b>WB</b> (Model: HK660) <b>IB</b>	210	2557-F301426	SCREW, B SPW+ (3x14 mm) (x9) (Model: HK640)
150	1630-05001	ROTARY KNOB, VOLUME (Model: HK640/660) <b>I</b>	210	2557-F301426	SCREW, B SPW+ (3x14 mm) (x10) (Model: HK660)
151	1632-20702	ROTARY KNOB, BASS, TREBLE, BALANCE (x3) (Model: HK640) <b>IB</b> <b>WB</b> (Model: HK660) <b>IB</b>	213	2412-4022	WASHER, SPRG (x4)
151	1632-20701	ROTARY KNOB, BASS, TREBLE, BALANCE (x3) (Model: HK640/660) <b>I</b>	214	2401-0472	WASHER, METAL (x4)
154	1732-09801	INDICATOR, TAPE1/COPY, CD, AUX (x3)			
155	1732-09901	INDICATOR, TAPE2 MON, TUNER, VIDEO (x3)			
157	1742-09402	ORNAMENT, SPEAKERS 1/2 BUTTON (Model: HK640) <b>IB</b> <b>WB</b> (Model: HK660) <b>IB</b>			
157	1742-09401	ORNAMENT, SPEAKERS 1/2 BUTTON (Model: HK640/660) <b>I</b>			
159	1319-04303	LEG (x4)			
160	1319-04601	LEG, SPONGE (x4)			
161	2211-7330	CHASSIS			
164	2219-8422	METAL FITTG, HEAT SINK			
166	2219-8424	METAL FITTG, R SIDE TOP			
168	2219-8349	METAL FITTG, POWER IN SIDE			
169	2219-8390	METAL FITTG, POWER IN			
170	2216-7210	SHIELD PLATE			
173	2222-7342	HEAT SINK (Model: HK640)			
173	2222-7341	HEAT SINK (Model: HK660)			
175	2224-146	INSULATOR, TOP COVER (x2)			

P.C. BOARDS

1  
2  
3  
4  
5  
6  
7

PCB-5 CPU P.C.BOARD

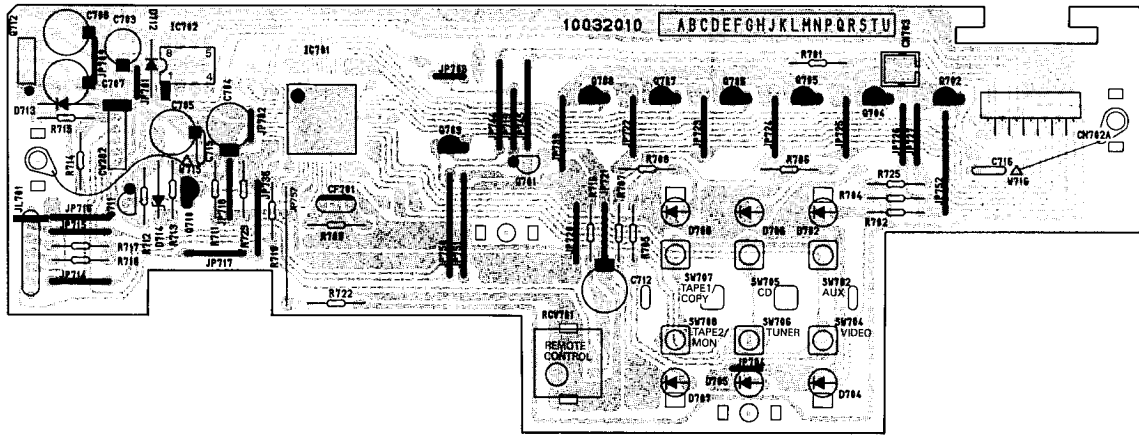

PCB-6 I/O P.C.BOARD (MODEL: HK640)

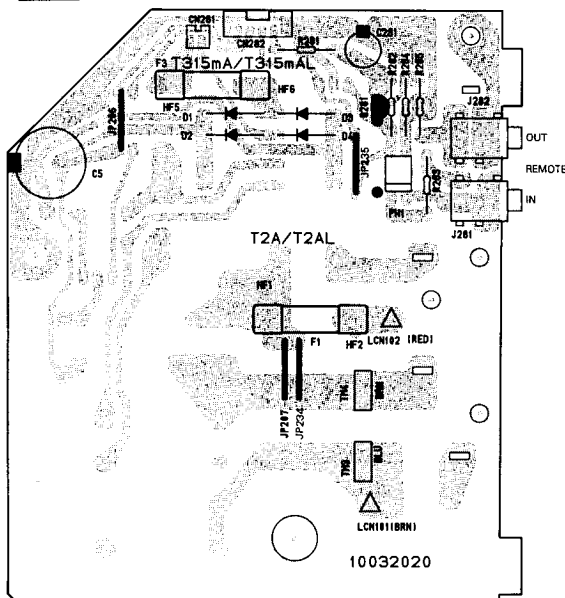

PCB-6 I/O P.C.BOARD (MODEL: HK660)

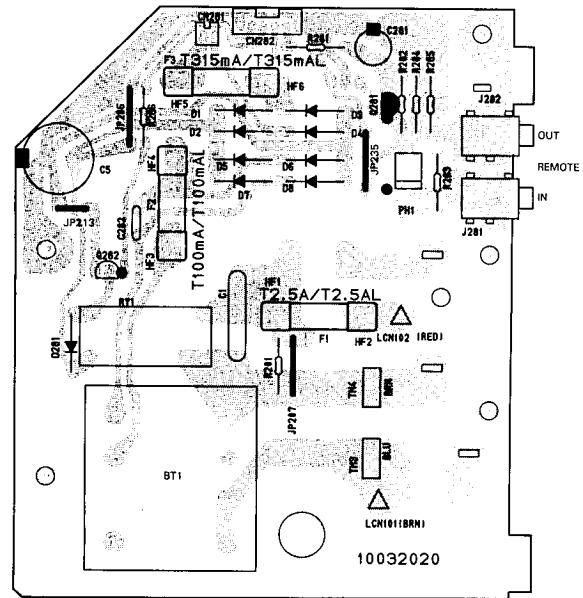

PCB-4 SP TERMINAL P.C.BOARD (MODEL: HK660)

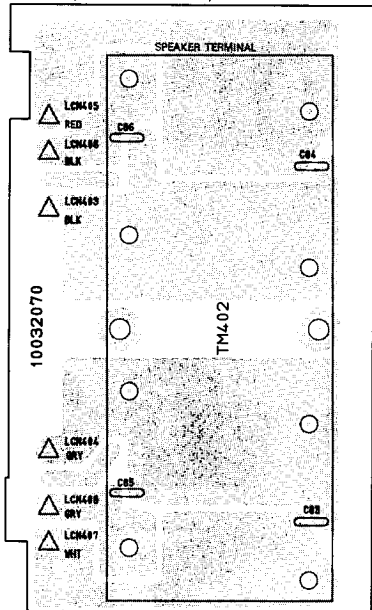

PCB-7 POWER INDICATOR P.C.BOARD

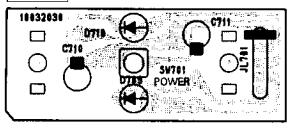

PCB-9 POWER TRANS P.C.BOARD(MODEL: HK640)

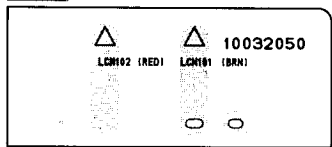

PCB-8 VOLUME INDICATOR P.C.BOARD

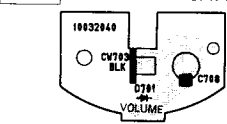

PCB-10 VOLUME P.C.BOARD

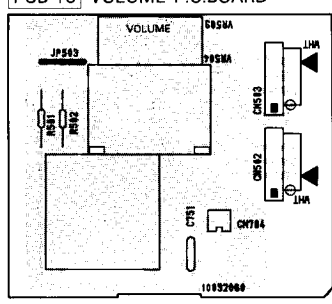





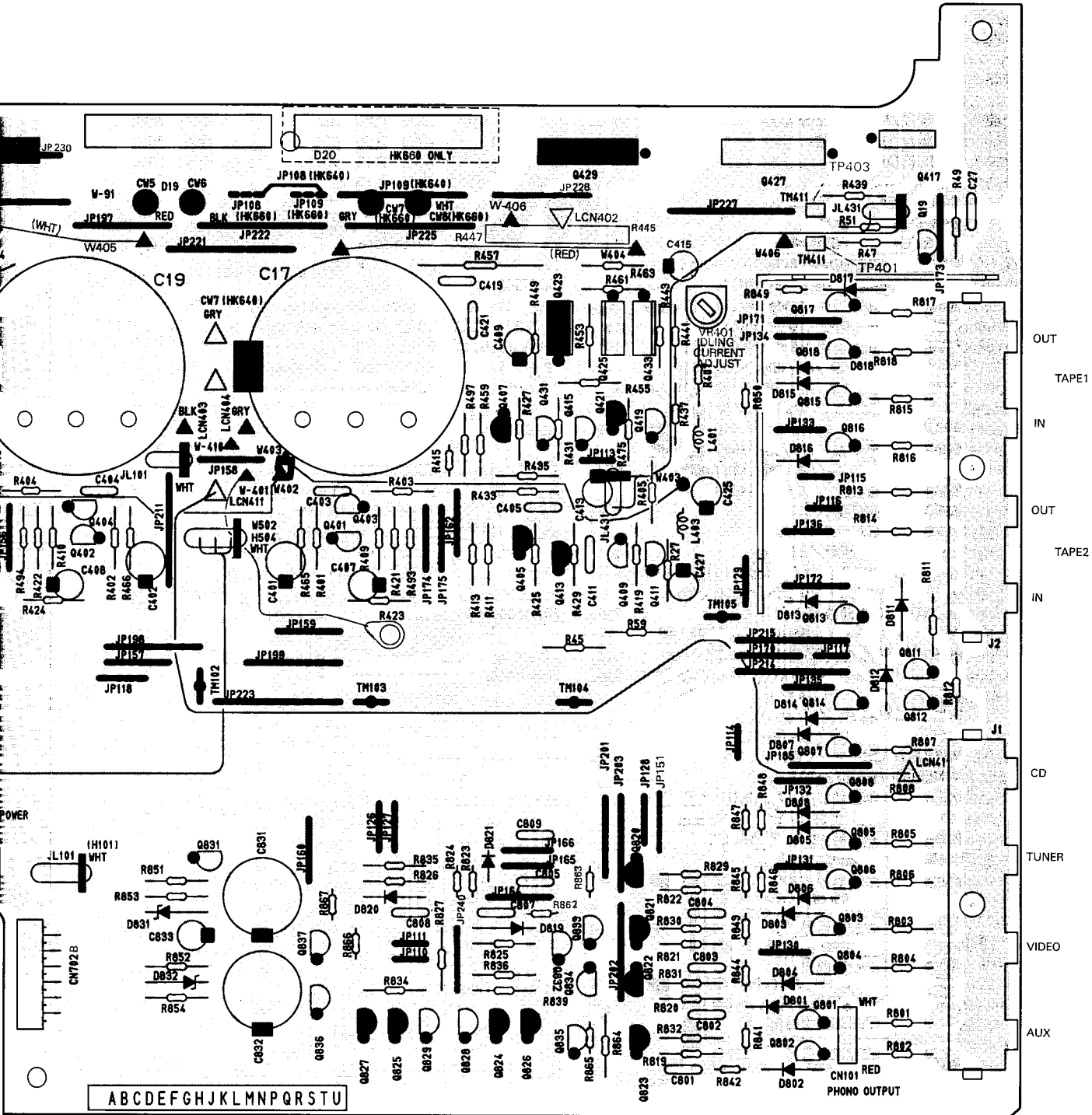

OUT TAPE1  
IN TAPE1  
OUT TAPE2  
IN TAPE2  
CD  
TUNER  
VIDEO  
AUX

PCB-4 SP TERMINAL P.C. BOARD (MODEL: HK640)

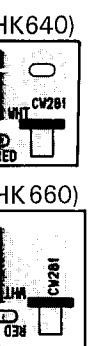
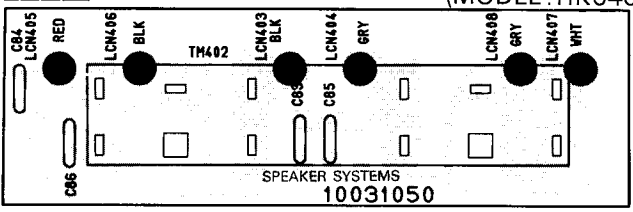

# ELECTRICAL PARTS LIST

Ser. No.	Ref. No.	Part No.	Description	Ser. No.	Ref. No.	Part No.	Description
<b>PCB - MAIN P.C. BOARD</b>							
<b>CAPACITORS</b>							
724	△ C17	5341-S45GM159	CAP, ELE 15000U/63V (Model: HK640)	709	R45	5130-R030J682	RES, CBN 1/2P 6.8K
724	△ C17	5341-S45GM189	CAP, ELE 18000U/63V (Model: HK660)	709	R46	5130-R030J682	RES, CBN 1/2P 6.8K
724	△ C19	5341-S45GM159	CAP, ELE 15000U/63V (Model: HK640)	710	R47	5130-R030J222	RES, CBN 1/2P 2.2K (Model: HK640)
724	△ C19	5341-S45GM189	CAP, ELE 18000U/63V (Model: HK660)	710	R47	5130-R030J272	RES, CBN 1/2P 2.7K (Model: HK660)
691	C24	5354-104593	CAP, MYL .1U	710	R48	5130-R030J222	RES, CBN 1/2P 2.2K (Model: HK640)
693	C26	5354-104593	CAP, MYL .1U	710	R48	5130-R030J272	RES, CBN 1/2P 2.7K (Model: HK660)
692	C27	5354-124593	CAP, MYL .12U	711	R49	5130-R030J821	RES, CBN 1/2P 820
692	C28	5354-124593	CAP, MYL .12U	711	R50	5130-R030J821	RES, CBN 1/2P 820
701	C61	5359-S010J332	CAP, PPP 3300P	710	R51	5130-R030J222	RES, CBN 1/2P 2.2K (Model: HK640)
694	C92	5345-476F041	CAP, MINI ELE 47U/50V	710	R51	5130-R030J272	RES, CBN 1/2P 2.7K (Model: HK660)
601	C401	5345-S29AM227	CAP, MINI ELE 220U/6.3V	710	R52	5130-R030J222	RES, CBN 1/2P 2.2K (Model: HK640)
601	C402	5345-S29AM227	CAP, MINI ELE 220U/6.3V	710	R52	5130-R030J272	RES, CBN 1/2P 2.7K (Model: HK660)
610	C403	5359-S010K221	CAP, PPP 220P	705	R54	5130-R030J223	RES, CBN 1/2P 22K
610	C404	5359-S010K221	CAP, PPP 220P	712	R59	5130-R030J123	RES, CBN 1/2P 12K
602	C405	5353-020933	CAP, MCA 2P	712	R60	5130-R030J123	RES, CBN 1/2P 12K
602	C406	5353-020933	CAP, MCA 2P	715	R61	5130-R030J152	RES, CBN 1/2P 1.5K
603	C407	5345-S29BM107	CAP, MINI ELE 100U/10V	716	R62	5130-R030J473	RES, CBN 1/2P 47K
603	C408	5345-S29BM107	CAP, MINI ELE 100U/10V	717	R63	5130-R030J223	RES, CBN 1/2P 22K
607	C409	5345-S29FM106	CAP, MINI ELE 10U/50V	718	R64	5130-R030J103	RES, CBN 1/2P 10K
607	C410	5345-S29FM106	CAP, MINI ELE 10U/50V	714	R94	5130-R030J104	RES, CBN 1/2P 100K
606	C411	5353-070933	CAP, MCA 7P	704	R96	5130-R030J472	RES, CBN 1/2P 4.7K
606	C412	5353-070933	CAP, MCA 7P	705	R97	5130-R030J223	RES, CBN 1/2P 22K
604	C413	5345-S29CM106	CAP, MINI ELE 10U/16V	713	R98	5130-R030J333	RES, CBN 1/2P 33K
604	C414	5345-S29CM106	CAP, MINI ELE 10U/16V	631	R401	5130-R030J683	RES, CBN 1/2P 68K
609	C415	5345-S25JM106	CAP, MINI ELE 10U/100V	631	R402	5130-R030J683	RES, CBN 1/2P 68K
609	C416	5345-S25JM106	CAP, MINI ELE 10U/100V	627	R403	5130-R030J562	RES, CBN 1/2P 5.6K
605	C419	5354-224593	CAP, MYL .22U	627	R404	5130-R030J562	RES, CBN 1/2P 5.6K
605	C420	5354-224593	CAP, MYL .22U	643	△ R405	5102-3R35116	RES, FUSE 3.3
605	C421	5354-224593	CAP, MYL .22U	643	△ R406	5102-3R35116	RES, FUSE 3.3
605	C422	5354-224593	CAP, MYL .22U	643	△ R407	5102-3R35116	RES, FUSE 3.3
608	C425	5345-S29GM105	CAP, MINI ELE 1U/63V	643	△ R408	5102-3R35116	RES, FUSE 3.3
608	C426	5345-S29GM105	CAP, MINI ELE 1U/63V	633	R409	5130-R030J473	RES, CBN 1/2P 47K
608	C427	5345-S29GM105	CAP, MINI ELE 1U/63V	633	R410	5130-R030J473	RES, CBN 1/2P 47K
608	C428	5345-S29GM105	CAP, MINI ELE 1U/63V	634	△ R411	5102-1025116	RES, FUSE 1K
670	C501	5359-4715851	CAP, PPP 470P	634	△ R412	5102-1025116	RES, FUSE 1K
670	C502	5359-4715851	CAP, PPP 470P	632	△ R413	5102-1024715	RES, FUSE 1K
661	C581	5345-S29BM476	CAP, MINI ELE 47U/10V	632	△ R414	5102-1024715	RES, FUSE 1K
661	C582	5345-S29BM476	CAP, MINI ELE 47U/10V	629	△ R415	5102-S081J470	RES, FUSE 47
669	C585	5354-823593	CAP, MYL .082U	629	△ R416	5102-S081J470	RES, FUSE 47
669	C586	5354-823593	CAP, MYL .082U	635	R419	5130-R030J271	RES, CBN 1/2P 270
663	C587	5354-334593	CAP, MYL .33U	635	R420	5130-R030J271	RES, CBN 1/2P 270
663	C588	5354-334593	CAP, MYL .33U	636	R421	5130-R030J224	RES, CBN 1/2P 220K
664	C589	5345-S29AM227	CAP, MINI ELE 220U/6.3V	636	R422	5130-R030J224	RES, CBN 1/2P 220K
664	C590	5345-S29AM227	CAP, MINI ELE 220U/6.3V	637	R423	5130-R030J121	RES, CBN 1/2P 120 (Model: HK640)
666	C591	5359-8225851	CAP, PPP 8200P	637	R423	5130-R030J111	RES, CBN 1/2P 110 (Model: HK660)
666	C592	5359-8225851	CAP, PPP 8200P	637	R424	5130-R030J121	RES, CBN 1/2P 120 (Model: HK640)
668	C593	5354-563593	CAP, MYL .056U	637	R424	5130-R030J111	RES, CBN 1/2P 110 (Model: HK660)
668	C594	5354-563593	CAP, MYL .056U	645	△ R425	5102-8205116	RES, FUSE 82
877	C801	5352-S110J104	CAP, MTL .1U	645	△ R426	5102-8205116	RES, FUSE 82
877	C802	5352-S110J104	CAP, MTL .1U	648	△ R427	5102-6805116	RES, FUSE 68
877	C803	5352-S110J104	CAP, MTL .1U	648	△ R428	5102-6805116	RES, FUSE 68
877	C804	5352-S110J104	CAP, MTL .1U	645	△ R429	5102-8205116	RES, FUSE 82
879	C805	5352-S110J224	CAP, MTL .22U	645	△ R430	5102-8205116	RES, FUSE 82
879	C807	5352-S110J224	CAP, MTL .22U	645	△ R431	5102-8205116	RES, FUSE 82
879	C808	5352-S110J224	CAP, MTL .22U	645	△ R432	5102-8205116	RES, FUSE 82
877	C809	5352-S110J104	CAP, MTL .1U	638	R433	5130-R030J183	RES, CBN 1/2P 18K
880	C831	5345-S25GM337	CAP, MINI ELE 330U/63V	638	R434	5130-R030J183	RES, CBN 1/2P 18K
880	C832	5345-S25GM337	CAP, MINI ELE 330U/63V	638	R435	5130-R030J183	RES, CBN 1/2P 18K
878	C833	5345-107D041	CAP, MINI ELE 100U/25V	638	R436	5130-R030J183	RES, CBN 1/2P 18K
<b>RESISTORS</b>							
702	R27	5130-R030J104	RES, CBN 1/2P 100K	656	R437	5130-R030J182	RES, CBN 1/2P 1.8K
702	R28	5130-R030J104	RES, CBN 1/2P 100K	656	R438	5130-R030J182	RES, CBN 1/2P 1.8K
706	R30	5130-R030J683	RES, CBN 1/2P 68K	640	R439	5130-R030J681	RES, CBN 1/2P 680
702	R33	5130-R030J104	RES, CBN 1/2P 100K	640	R440	5130-R030J681	RES, CBN 1/2P 680
704	R34	5130-R030J472	RES, CBN 1/2P 4.7K	639	R441	5130-R030J122	RES, CBN 1/2P 1.2K
705	R35	5130-R030J223	RES, CBN 1/2P 22K	639	R442	5130-R030J122	RES, CBN 1/2P 1.2K
705	R36	5130-R030J223	RES, CBN 1/2P 22K	655	R443	5130-R030J122	RES, CBN 1/2P 1.2K
706	R38	5130-R030J683	RES, CBN 1/2P 68K	655	R444	5130-R030J122	RES, CBN 1/2P 1.2K
				650	R445	5275-S040JR22	RES, CEM 5P .22
				650	R446	5275-S040JR22	RES, CEM 5P .22
				650	R447	5275-S040JR22	RES, CEM 5P .22
				650	R448	5275-S040JR22	RES, CEM 5P .22
				646	△ R449	5102-2214715	RES, FUSE 220
				646	△ R450	5102-2214715	RES, FUSE 220

Ser. No.	Ref. No.	Part No.	Description	Ser. No.	Ref. No.	Part No.	Description
644	△ R453	5102-1014715	RES, FUSE 100	903	△ R851	5102-2205116	RES, FUSE 22
644	△ R454	5102-1014715	RES, FUSE 100	906	R852	5130-R030J392	RES, CBN 1/2P 3.9K (Model: HK640)
644	△ R455	5102-1014715	RES, FUSE 100	906	R852	5130-R030J472	RES, CBN 1/2P 4.7K (Model: HK660)
644	△ R456	5102-1014715	RES, FUSE 100	904	R853	5130-R030J103	RES, CBN 1/2P 10K
652	R457	5173-3R3583	RES, MTL 2P 3.3	905	R854	5130-R030J222	RES, CBN 1/2P 2.2K
652	R458	5173-3R3583	RES, MTL 2P 3.3	895	R862	5130-R010J102	RES, CBN 1/6P 1K
641	R459	5130-R030J332	RES, CBN 1/2P 3.3K	895	R863	5130-R010J102	RES, CBN 1/6P 1K
641	R460	5130-R030J332	RES, CBN 1/2P 3.3K	894	R864	5130-R030J102	RES, CBN 1/2P 1K
649	△ R461	5102-4R75116	RES, FUSE 4.7	895	R865	5130-R010J102	RES, CBN 1/6P 1K
649	△ R462	5102-4R75116	RES, FUSE 4.7	895	R866	5130-R010J102	RES, CBN 1/6P 1K
649	△ R463	5102-4R75116	RES, FUSE 4.7	895	R867	5130-R010J102	RES, CBN 1/6P 1K
649	△ R464	5102-4R75116	RES, FUSE 4.7				
642	R465	5130-R030J331	RES, CBN 1/2P 330			<b>TRANSISTORS</b>	
642	R466	5130-R030J331	RES, CBN 1/2P 330	696	Q14	5613-1740S(S)	XISTOR, NPN R
647	△ R475	5102-3914715	RES, FUSE 390	696	Q15	5613-1740S(S)	XISTOR, NPN R
647	△ R476	5102-3914715	RES, FUSE 390	697	Q16	5611-933S(S)	XISTOR, PNP R
642	R493	5130-R030J331	RES, CBN 1/2P 330	696	Q17	5613-1740S(S)	XISTOR, NPN R
642	R494	5130-R030J331	RES, CBN 1/2P 330	698	Q19	5613-2240(BL)	XISTOR, NPN R
633	R497	5130-R030J473	RES, CBN 1/2P 47K	698	Q20	5613-2240(BL)	XISTOR, NPN R
633	R498	5130-R030J473	RES, CBN 1/2P 47K	699	Q61	5611-970(BL)	XISTOR, PNP R
671	R503	5130-R030J102	RES, CBN 1/2P 1K	697	Q91	5611-933S(S)	XISTOR, PNP R
671	R504	5130-R030J102	RES, CBN 1/2P 1K	613	Q401	5613-1775(F)	XISTOR, NPN R
672	R581	5130-R030J822	RES, CBN 1/2P 8.2K	613	Q402	5613-1775(F)	XISTOR, NPN R
672	R582	5130-R030J822	RES, CBN 1/2P 8.2K	613	Q403	5613-1775(F)	XISTOR, NPN R
673	R583	5130-R030J152	RES, CBN 1/2P 1.5K	613	Q404	5613-1775(F)	XISTOR, NPN R
673	R584	5130-R030J152	RES, CBN 1/2P 1.5K	614	Q405	5612-646A(C)	XISTOR, PNP A
674	R587	5130-R030J271	RES, CBN 1/2P 270	614	Q406	5612-646A(C)	XISTOR, PNP A
674	R588	5130-R030J271	RES, CBN 1/2P 270	614	Q407	5612-646A(C)	XISTOR, PNP A
675	R589	5130-R030J335	RES, CBN 1/2P 3.3M	614	Q408	5612-646A(C)	XISTOR, PNP A
675	R590	5130-R030J335	RES, CBN 1/2P 3.3M	615	Q409	5613-2240(BL)	XISTOR, NPN R
676	R591	5130-R030J122	RES, CBN 1/2P 1.2K	615	Q410	5613-2240(BL)	XISTOR, NPN R
676	R592	5130-R030J122	RES, CBN 1/2P 1.2K	615	Q411	5613-2240(BL)	XISTOR, NPN R
896	R801	5130-R030J102	RES, CBN 1/2P 1K	615	Q412	5613-2240(BL)	XISTOR, NPN R
896	R802	5130-R030J102	RES, CBN 1/2P 1K	614	Q413	5612-646A(C)	XISTOR, PNP A
896	R803	5130-R030J102	RES, CBN 1/2P 1K	614	Q414	5612-646A(C)	XISTOR, PNP A
896	R804	5130-R030J102	RES, CBN 1/2P 1K	616	Q415	5614-666A(C)	XISTOR, NPN A
896	R805	5130-R030J102	RES, CBN 1/2P 1K	616	Q416	5614-666A(C)	XISTOR, NPN A
896	R806	5130-R030J102	RES, CBN 1/2P 1K	617	Q417	5613-3423(Y)	XISTOR, NPN R
896	R807	5130-R030J102	RES, CBN 1/2P 1K	617	Q418	5613-3423(Y)	XISTOR, NPN R
896	R808	5130-R030J102	RES, CBN 1/2P 1K	618	Q419	5614-667A(C)	XISTOR, NPN A
896	R811	5130-R030J102	RES, CBN 1/2P 1K	618	Q420	5614-667A(C)	XISTOR, NPN A
896	R812	5130-R030J102	RES, CBN 1/2P 1K	619	Q421	5612-647A(C)	XISTOR, PNP A
896	R813	5130-R030J102	RES, CBN 1/2P 1K	619	Q422	5612-647A(C)	XISTOR, PNP A
897	R814	5130-R030J102	RES, CBN 1/2P 1K	620	Q423	5611-1837(Y)	XISTOR, PNP R
897	R815	5130-R030J102	RES, CBN 1/2P 1K	620	Q424	5611-1837(Y)	XISTOR, PNP R
897	R816	5130-R030J102	RES, CBN 1/2P 1K	621	Q425	5613-4793(Y)	XISTOR, NPN R
897	R817	5130-R030J102	RES, CBN 1/2P 1K	621	Q426	5613-4793(Y)	XISTOR, NPN R
897	R818	5130-R030J102	RES, CBN 1/2P 1K	623	Q427	5613-3907(O)	XISTOR, NPN R
901	R819	5130-R030J225	RES, CBN 1/2P 2.2M	623	Q427	5613-3281(O)	XISTOR, NPN R
901	R820	5130-R030J225	RES, CBN 1/2P 2.2M	623	Q428	5613-3907(O)	XISTOR, NPN R
901	R821	5130-R030J225	RES, CBN 1/2P 2.2M	623	Q428	5613-3281(O)	XISTOR, NPN R
901	R822	5130-R030J225	RES, CBN 1/2P 2.2M	624	Q429	5611-1516(O)	XISTOR, PNP R
893	R823	5130-R010J225	RES, CBN 1/6P 2.2M	624	Q429	5611-1302(O)	XISTOR, PNP R
898	R824	5130-R010J225	RES, CBN 1/6P 2.2M	624	Q430	5611-1516(O)	XISTOR, PNP R
899	R825	5130-R030J155	RES, CBN 1/2P 1.5M	624	Q430	5611-1302(O)	XISTOR, PNP R
899	R826	5130-R030J155	RES, CBN 1/2P 1.5M	612	Q431	5613-1775(F)	XISTOR, NPN R
901	R827	5130-R030J225	RES, CBN 1/2P 2.2M	612	Q432	5613-1775(F)	XISTOR, NPN R
900	R829	5130-R030J104	RES, CBN 1/2P 100K	617	Q433	5613-3423(Y)	XISTOR, NPN R
900	R830	5130-R030J104	RES, CBN 1/2P 100K	617	Q434	5613-3423(Y)	XISTOR, NPN R
900	R831	5130-R030J104	RES, CBN 1/2P 100K	887	Q801	5616-2SK364BL	FET, N-CH
900	R832	5130-R030J104	RES, CBN 1/2P 100K	887	Q802	5616-2SK364BL	FET, N-CH
900	R834	5130-R030J104	RES, CBN 1/2P 100K	887	Q803	5616-2SK364BL	FET, N-CH
900	R835	5130-R030J104	RES, CBN 1/2P 100K	887	Q804	5616-2SK364BL	FET, N-CH
900	R836	5130-R030J104	RES, CBN 1/2P 100K	887	Q805	5616-2SK364BL	FET, N-CH
900	R839	5130-R030J104	RES, CBN 1/2P 100K	887	Q806	5616-2SK364BL	FET, N-CH
902	R841	5130-R010J225	RES, CBN 1/6P 2.2M	887	Q807	5616-2SK364BL	FET, N-CH
902	R842	5130-R010J225	RES, CBN 1/6P 2.2M	887	Q808	5616-2SK364BL	FET, N-CH
902	R843	5130-R010J225	RES, CBN 1/6P 2.2M	887	Q811	5616-2SK364BL	FET, N-CH
902	R844	5130-R010J225	RES, CBN 1/6P 2.2M	887	Q812	5616-2SK364BL	FET, N-CH
902	R845	5130-R010J225	RES, CBN 1/6P 2.2M	889	Q813	5616-2SK364(V)	FET, N-CH
902	R846	5130-R010J225	RES, CBN 1/6P 2.2M	889	Q814	5616-2SK364(V)	FET, N-CH
902	R847	5130-R010J225	RES, CBN 1/6P 2.2M	887	Q815	5616-2SK364BL	FET, N-CH
902	R848	5130-R010J225	RES, CBN 1/6P 2.2M	888	Q816	5616-2SK364BL	FET, N-CH
902	R849	5130-R010J225	RES, CBN 1/6P 2.2M	888	Q817	5616-2SK364BL	FET, N-CH
902	R850	5130-R010J225	RES, CBN 1/6P 2.2M	888	Q818	5616-2SK364BL	FET, N-CH

(Model: HK640)  
(Model: HK660)  
(Model: HK640)  
(Model: HK660)  
(Model: HK640)  
(Model: HK660)  
(Model: HK640)  
(Model: HK660)



Ser. No.	Ref. No.	Part No.	Description
<b>PCB-3 SECOND P.C. BOARD</b>			
<b>CAPACITORS</b>			
721	C2	5352-S060K104	CAP, MTL .1U
721	C3	5352-S060K104	CAP, MTL .1U
722	C4	5354-104593	CAP, MYL .1U

Ser. No.	Ref. No.	Part No.	Description
<b>MISCELLANEOUS</b>			
790	CW281	4163-S0202301	CONNECTOR W/W, 2 PIN

Ser. No.	Ref. No.	Part No.	Description
<b>PCB-4 SP TERMINAL P.C. BOARD</b>			
<b>CAPACITORS</b>			
657	C83	5359-S010K151	CAP, PPP 150P
657	C84	5359-S010K151	CAP, PPP 150P
657	C85	5359-S010K151	CAP, PPP 150P
657	C86	5359-S010K151	CAP, PPP 150P

Ser. No.	Ref. No.	Part No.	Description
<b>MISCELLANEOUS</b>			
812	TM402	4214-239	TERMINAL, SPEAKER SYSTEM 1/2 (Model: HK640)
812	TM402	4214-221	TERMINAL, SPEAKER SYSTEM 1/2 (Model: HK660)

Ser. No.	Ref. No.	Part No.	Description
<b>PCB-5 CPU P.C. BOARD</b>			
<b>CAPACITORS</b>			
841	C703	5345-S35BM107	CAP, MINI ELE 100U/10V
842	C704	5345-S35BM107	CAP, MINI ELE 100U/10V
841	C705	5345-S35BM107	CAP, MINI ELE 100U/10V
844	C706	5345-S35BM227	CAP, MINI ELE 220U/10V
844	C707	5345-S35BM227	CAP, MINI ELE 220U/10V
842	C712	5345-S35BM107	CAP, MINI ELE 100U/10V
845	C715	5354-104593	CAP, MYL .1U
845	C716	5354-104593	CAP, MYL .1U

Ser. No.	Ref. No.	Part No.	Description
<b>RESISTORS</b>			
861	R701	5130-R030J331	RES, CBN 1/2P 330
862	R702	5130-R030J471	RES, CBN 1/2P 470
862	R704	5130-R030J471	RES, CBN 1/2P 470
862	R705	5130-R030J471	RES, CBN 1/2P 470
862	R706	5130-R030J471	RES, CBN 1/2P 470
863	R707	5130-R030J561	RES, CBN 1/2P 560
862	R708	5130-R030J471	RES, CBN 1/2P 470
864	R709	5130-R030J105	RES, CBN 1/2P 1M
866	R711	5130-R030J103	RES, CBN 1/2P 10K
862	R712	5130-R030J471	RES, CBN 1/2P 470
867	R713	5130-R030J102	RES, CBN 1/2P 1K
868	R714	5102-4R75116	RES, FUSE 4.7
869	R715	5130-R030J392	RES, CBN 1/2P 3.9K
865	R716	5130-R030J101	RES, CBN 1/2P 100
862	R717	5130-R030J471	RES, CBN 1/2P 470
862	R718	5130-R030J471	RES, CBN 1/2P 470
867	R719	5130-R030J102	RES, CBN 1/2P 1K
849	R722	5130-R030J103	RES, CBN 1/2P 10K
866	R723	5130-R030J103	RES, CBN 1/2P 10K
847	R725	5130-R030J104	RES, CBN 1/2P 100K

Ser. No.	Ref. No.	Part No.	Description
<b>INTEGRATED CIRCUITS</b>			
855	IC701	5654-T7C2BF-1	IC, DIGITAL
856	IC702	5653-LB1639	IC, LINEAR

Ser. No.	Ref. No.	Part No.	Description
<b>TRANSISTORS</b>			
850	Q701	5613-R01D1000	XISTOR, NPN R, RN1211 or DTC114TS or UN4215
857	Q702	5611-R01D0505	XISTOR, PNP R, RN2201 or DTA143ES or UN411L
857	Q704	5611-R01D0505	XISTOR, PNP R, RN2201 or DTA143ES or UN411L

Ser. No.	Ref. No.	Part No.	Description
857	Q705	5611-R01D0505	XISTOR, PNP R, RN2201 or DTA143ES or UN411L
857	Q706	5611-R01D0505	XISTOR, PNP R, RN2201 or DTA143ES or UN411L
857	Q707	5611-R01D0505	XISTOR, PNP R, RN2201 or DTA143ES or UN411L
857	Q708	5611-R01D0505	XISTOR, PNP R, RN2201 or DTA143ES or UN411L
857	Q709	5611-R01D0505	XISTOR, PNP R, RN2201 or DTA143ES or UN411L
858	Q710	5611-R01D1010	XISTOR, PNP R, RN2202 or DTA114ES or UN4111
859	Q711	5613-1740S(S)	XISTOR, NPN R
860	Q712	5614-2012	XISTOR, NPN A

Ser. No.	Ref. No.	Part No.	Description
<b>DIODES</b>			
832	D702	5637-S2410E6A	LED, AUX
831	D704	5637-S2410E1A	LED, VIDEO
831	D705	5637-S2410E1A	LED, TUNER
832	D706	5637-S2410E6A	LED, CD
833	D707	5637-S2210S1	LED, TAPE 2 MON
832	D708	5637-S2410E6A	LED, TAPE 1/COPY
852	D712	5631-1S2473	DIODE, DET
853	D713	5635-HZ6A2L	DIODE, ZENER
854	D714	5635-HZ3B2	DIODE, ZENER

Ser. No.	Ref. No.	Part No.	Description
<b>MISCELLANEOUS</b>			
846	CF701	5693-FC4004A4	OSC, CER
808	CN702A	4443-05401013	CONNECTOR, 13 PIN
807	CN703	4443-0201140	CONNECTOR, 2 PIN
791	CW282	4163-S0206451	CONNECTOR W/W, 6 PIN
802	JL701	4242-R0505141	JUMPER LEAD, 5 WIRE
870	RCV701	6143-00804	RECEIVER UNIT, REMOTE SENSOR
818	SW702	4437-01301	SWITCH, PU-TC, AUX
818	SW704	4437-01301	SWITCH, PU-TC, VIDEO
818	SW705	4437-01301	SWITCH, PU-TC, CD
818	SW706	4437-01301	SWITCH, PU-TC, TUNER
818	SW707	4437-01301	SWITCH, PU-TC, TAPE 1/COPY
818	SW708	4437-01301	SWITCH, PU-TC, TAPE 1 MON
851	W715	4122-00220550	WIRE, LUG (Model: HK640)
851	W715	4122-00270550	WIRE, LUG (Model: HK660)
851	W716	4122-00220550	WIRE, LUG (Model: HK640)
851	W716	4122-00270550	WIRE, LUG (Model: HK660)
840		4211-4	LUG, (W715, 716) (x2)
871		2240-Z052	HOLDER, H701

**PCB-6 I/O P.C. BOARD (MODEL: HK640)**

Ser. No.	Ref. No.	Part No.	Description
<b>CAPACITORS</b>			
733	C5	5345-S25DM108	CAP, MINI ELE 1000U/25V
739	C281	5345-476D041	CAP, MINI ELE 47U/25V
<b>RESISTORS</b>			
747	R281	5130-R030J470	RES, CBN 1/2P 47
748	R282	5130-R030J392	RES, CBN 1/2P 3.9K
749	R283	5130-R030J271	RES, CBN 1/2P 270
750	R284	5130-R030J473	RES, CBN 1/2P 47K
747	R285	5130-R030J470	RES, CBN 1/2P 47

Ser. No.	Ref. No.	Part No.	Description
<b>TRANSISTOR</b>			
744	Q281	5611-R01D0505	XISTOR, PNP R, RN2201 or DTA143ES or UN411L

Ser. No.	Ref. No.	Part No.	Description
<b>DIODES</b>			
734	△ D1	5632-S5566B	DIODE, RECT
734	△ D2	5632-S5566B	DIODE, RECT
734	△ D3	5632-S5566B	DIODE, RECT
734	△ D4	5632-S5566B	DIODE, RECT

Ser. No.	Ref. No.	Part No.	Description
<b>MISCELLANEOUS</b>			
803	CN281	4443-0201140	CONNECTOR, 2 PIN
804	CN282	4443-0601140	CONNECTOR, 6 PIN
727	△ F1	5732-01601202	FUSE, T2A/T2AL 250V

Ser. No.	Ref. No.	Part No.	Description
728	△ F3	5732-01601311	FUSE, T315mA/T315mAL 250V
729	△ HF1	4472-04901	HOLDER, FUSE, F1
729	△ HF2	4472-04901	HOLDER, FUSE, F1
729	△ HF5	4472-04901	HOLDER, FUSE, F3
729	△ HF6	4472-04901	HOLDER, FUSE, F3
814	J281	4451-00184	JACK, 1P, REMOTE IN
814	J282	4451-00184	JACK, 1P, REMOTE OUT
788	LCN101	4163-S5101150	CONNECTOR W/W, 1 PIN
789	LCN102	4163-S5201150	CONNECTOR W/W, 1 PIN
743	PH1	5624-PC817	PHOTO COUPLR
785	△ TM3	4214-245	TERMINAL
785	△ TM4	4214-245	TERMINAL

**PCB-6 I/O P.C. BOARD (MODEL: HK660)**

Ser. No.	Ref. No.	Part No.	Description
<b>CAPACITORS</b>			
730	△ C1	5352-1030958	CAP, MTL .01U
733	C5	5345-S25DM108	CAP, MINI ELE 1000U/25V
739	C281	5345-476D041	CAP, MINI ELE 47U/25V
740	C282	5354-104593	CAP, MYL .1U
<b>RESISTORS</b>			
732	△ R201	5130-R030J335	RES, CBN 1/2P 3.3M
747	R281	5130-R030J470	RES, CBN 1/2P 47
748	R282	5130-R030J392	RES, CBN 1/2P 3.9K
749	R283	5130-R030J271	RES, CBN 1/2P 270
750	R284	5130-R030J473	RES, CBN 1/2P 47K
747	R285	5130-R030J470	RES, CBN 1/2P 47
751	R286	5130-R030J102	RES, CBN 1/2P 1K
<b>TRANSISTORS</b>			
744	Q281	5611-R01D0505	XISTOR, PNP R, RN2201 or DTA143ES or UN4215
745	Q282	5613-3246(H)	XISTOR, NPN R
<b>DIODES</b>			
734	△ D1	5632-S5566B	DIODE, RECT
734	△ D2	5632-S5566B	DIODE, RECT
734	△ D3	5632-S5566B	DIODE, RECT
734	△ D4	5632-S5566B	DIODE, RECT
734	△ D5	5632-S5566B	DIODE, RECT
734	△ D6	5632-S5566B	DIODE, RECT
734	△ D7	5632-S5566B	DIODE, RECT
734	△ D8	5632-S5566B	DIODE, RECT
741	D281	5631-1S2473	DIODE, DET
<b>MISCELLANEOUS</b>			
736	△ BT1	5584-T1101	XFORMER, SUB POWER
803	CN281	4443-0201140	CONNECTOR, 2 PIN
804	CN282	4443-0601140	CONNECTOR, 6 PIN
727	△ F1	5732-01601252	FUSE, T2.5A/T2.5AL 250V
726	△ F2	5732-01601101	FUSE, T100mA/T100mAL 250V
728	△ F3	5732-01601311	FUSE, T315mA/T315mAL 250V
729	△ HF1	4472-04901	HOLDER, FUSE, F1
729	△ HF2	4472-04901	HOLDER, FUSE, F1
729	△ HF3	4472-04901	HOLDER, FUSE, F2
729	△ HF4	4472-04901	HOLDER, FUSE, F2
729	△ HF5	4472-04901	HOLDER, FUSE, F3
729	△ HF6	4472-04901	HOLDER, FUSE, F3
814	J281	4451-00184	JACK, 1P, REMOTE IN
814	J282	4451-00184	JACK, 1P, REMOTE OUT
788	△ LCN101	4163-S4901170	CONNECTOR W/W, 1 PIN
789	△ LCN102	4163-S5001170	CONNECTOR W/W, 1 PIN
743	PH1	5624-PC817	PHOTO COUPLR
731	△ RY1	4331-02601	RELAY, DC
785	△ TM3	4214-245	TERMINAL
785	△ TM4	4214-245	TERMINAL

Ser. No.	Ref. No.	Part No.	Description
<b>PCB-7 POWER IND P.C. BOARD</b>			
<b>CAPACITORS</b>			
848	C710	5345-S35CM106	CAP, MINI ELE 10U/16V
848	C711	5345-S35CM106	CAP, MINI ELE 10U/16V
<b>DIODES</b>			
837	D709	5637-S2410E1A	LED, POWER
837	D710	5637-S2410E1A	LED, POWER
<b>MISCELLANEOUS</b>			
816	SW701	4437-00704	SWITCH, PU-TC, POWER

**PCB-8 VR IND P.C. BOARD**

Ser. No.	Ref. No.	Part No.	Description
<b>CAPACITOR</b>			
843	C708	5345-S35CM106	CAP, MINI ELE 10U/16V
<b>DIODE</b>			
835	D701	5637-SLR33MC3	LED, VOLUME
<b>MISCELLANEOUS</b>			
786	CW703	4163-01524002	CONNECTOR W/W, 2 PIN

**PCB-10 VR P.C. BOARD**

Ser. No.	Ref. No.	Part No.	Description
<b>CAPACITOR</b>			
828	C751	5354-104593	CAP, MYL .1U
<b>RESISTORS</b>			
830	R501	5130-R030J152	RES, CBN 1/2P 1.5K
830	R502	5130-R030J152	RES, CBN 1/2P 1.5K
<b>CONTROLS</b>			
826	VR503/504	6161-00902	VR BLOCK, 30K, VOLUME (MOTOR DRIVER)
<b>MISCELLANEOUS</b>			
778	CN502	4443-030185	CONNECTOR, 3 PIN
778	CN503	4443-030185	CONNECTOR, 3 PIN
797	CN704	4443-0201140	CONNECTOR, 2 PIN

**CHASSIS MISCELLANEOUS**

Ser. No.	Ref. No.	Part No.	Description
<b>MISCELLANEOUS</b>			
801	JL702	4242-S0313251	JUMPER LEAD, 13 WIRE
811	△ PG1	4161-09801192	CORD W/PLUG
723	△ PT1	5584-T4403	XFORMER, POWER (Model: HK640)
723	△ PT1	5584-T4504	XFORMER, POWER (Model: HK660)
924	PCB-9	4551-10032050	P.C. BOARD, PR

**PACKING PARTS LIST**

021	1756-23601	LABEL, (CH) LABEL, CARTON BOX
108	1111-1620J152	OWNER GUIDE
116	1756-03108	LABEL, (I) LABEL, CARTON
116	1756-03101	LABEL, (W) LABEL, CARTON
120	1241-R0160601	POLYETHY BAG, SET
121	1241-R0123351	POLYETHY BAG, IB
124	1221-867167	CARTON BOX (Model: HK640)
124	1221-857167	CARTON BOX (Model: HK660)
126	1222-7331	CUSHION, L
127	1222-7332	CUSHION, R
128	1223-R0420055	SOFT SHEET, SET
909	6142-08101	CONT BLOCK, REMOTE CONTROL
910	4191-0355	BATTERY, DRY
911	4161-08201102	CORD W/PLUG, REMOTE IN/OUT (x3)

**ABBREVIATIONS IN PARTS LIST**

**CAPACITORS**

CAP, MINI ELE : Electrolytic  
CAP, CER : Ceramic  
CAP, PPP : Polypropylene  
CAP, MYL : Mylar  
CAP, MCA : Mica  
CAP, MINI BP : Bipolar  
CAP, ELE BP : Electrolytic Bipolar  
470U : 470 $\mu$ F  
6800P : 6800pF  
.047U : 0.047 $\mu$ F

**RESISTORS**

RES, CBN 1/6P : Carbon 1/6W  
RES, FUSE : Fuse  
RES, CEM 5P : Cement 5W  
RES, MTL 1P : Metal 1W  
2.2k : 2.2k $\Omega$   
220 : 220 $\Omega$

**TRANSISTORS**

XISTOR : Transistor  
FET : Field Effect Transistor

**CONTROLS**

RES, V CBN : Variable Carbon Resistor  
RES, SEMI FIX : Semi-fixed Resistor

**NOTE**



**SAFETY RELATED COMPONENT. USE ONLY EXACT REPLACEMENT PART AS SPECIFIED.**



## IC TERMINAL FUNCTION

## IC701: TMP47C200BF

Pin No.	Pin Name	I/O	Function
1	R51	I/O	4-bit w/latch input/output port
2	R52	I/O	4-bit w/latch input/output port
3	R53	I/O	4-bit w/latch input/output port
4	R60	I/O	4-bit w/latch input/output port
5	R61	I/O	4-bit w/latch input/output port
6	R62	I/O	4-bit w/latch input/output port
7	R63	I/O	4-bit w/latch input/output port
8	R70	I/O	4-bit w/latch input/output port
9	R71	I/O	4-bit w/latch input/output port
10	R72	I/O	4-bit w/latch input/output port
11	R73	I/O	4-bit w/latch input/output port
12	P10	O	4-bit w/latch output port
13	P11	O	4-bit w/latch output port
14	P12	O	4-bit w/latch output port
15	P13	O	4-bit w/latch output port
16	VSS	I	0V (GND)
17	N.C.	-	Non connect
18	P20	O	4-bit w/latch output port
19	P21	O	4-bit w/latch output port
20	P22	O	4-bit w/latch output port
21	P23	O	4-bit w/latch output port
22	K00	I	4-bit input port
23	K01	I	4-bit input port
24	K02	I	4-bit input port
25	K03	I	4-bit input port
26	TEST	I	Test point terminal
27	XIN	I	Crystal oscillator input
28	XOUT	O	Crystal oscillator output
29	RESET	I	Reset signal input
30	HOLD(KEO)	I	Sens input
31	R80(INT2)	I/O	External interruption 2 input
32	R81(T2)	I/O	Timer/counter 2 input
33	R82(INT1)	I/O	External interruption 1 input
34	R83(T1)	I/O	4-bit w/latch input/output, timer/counter input
35	R90(SI)	I	Serial data input
36	R91(SO)	O	Serial data output
37	R92(SCK)	I/O	Serial clock input/output
38	N.C.	-	Non connect
39	VDD	I	+5V Power supply
40	R40	I/O	4-bit input/output port
41	R41	I/O	4-bit input/output port
42	R42	I/O	4-bit input/output port
43	R43	I/O	4-bit input/output port
44	R50	I/O	4-bit input/output port

IC BLOCK DIAGRAM

IC701: TMP47C200BF

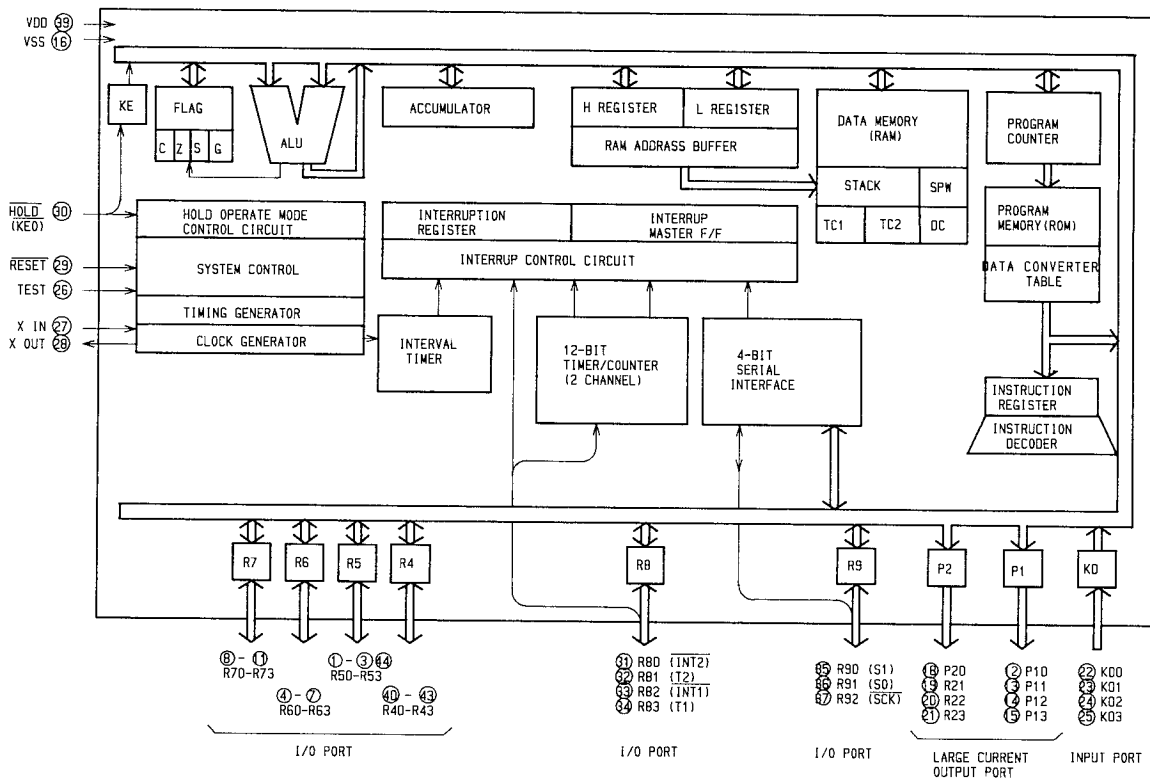

INFRA-RED REMOTE CONTROL SCHEMATIC DIAGRAM

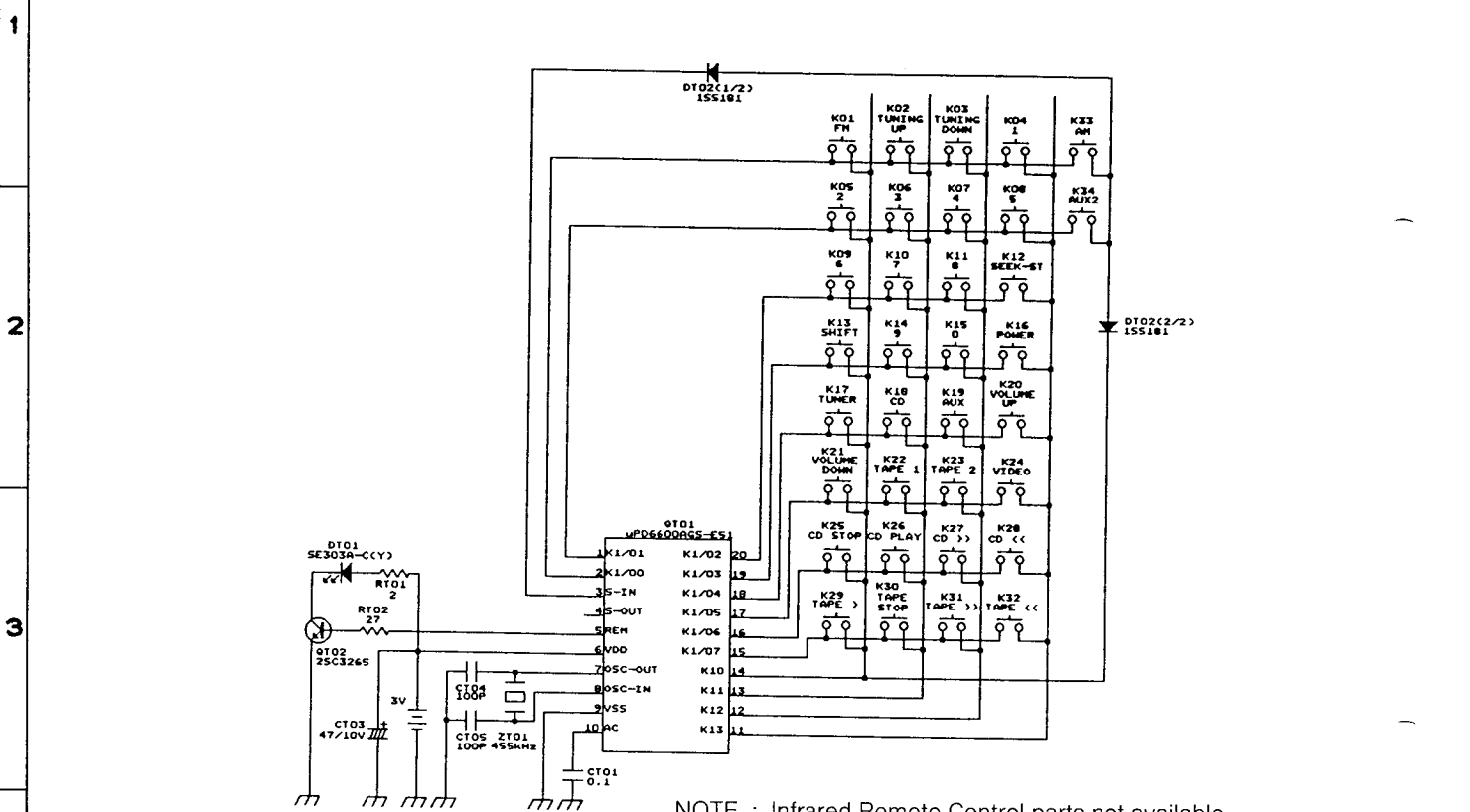

NOTE : Infrared Remote Control parts not available.  
Schematic diagram is supplied for reference only.

# WIRING DIAGRAM

1  
2  
3  
4  
5  
6  
7

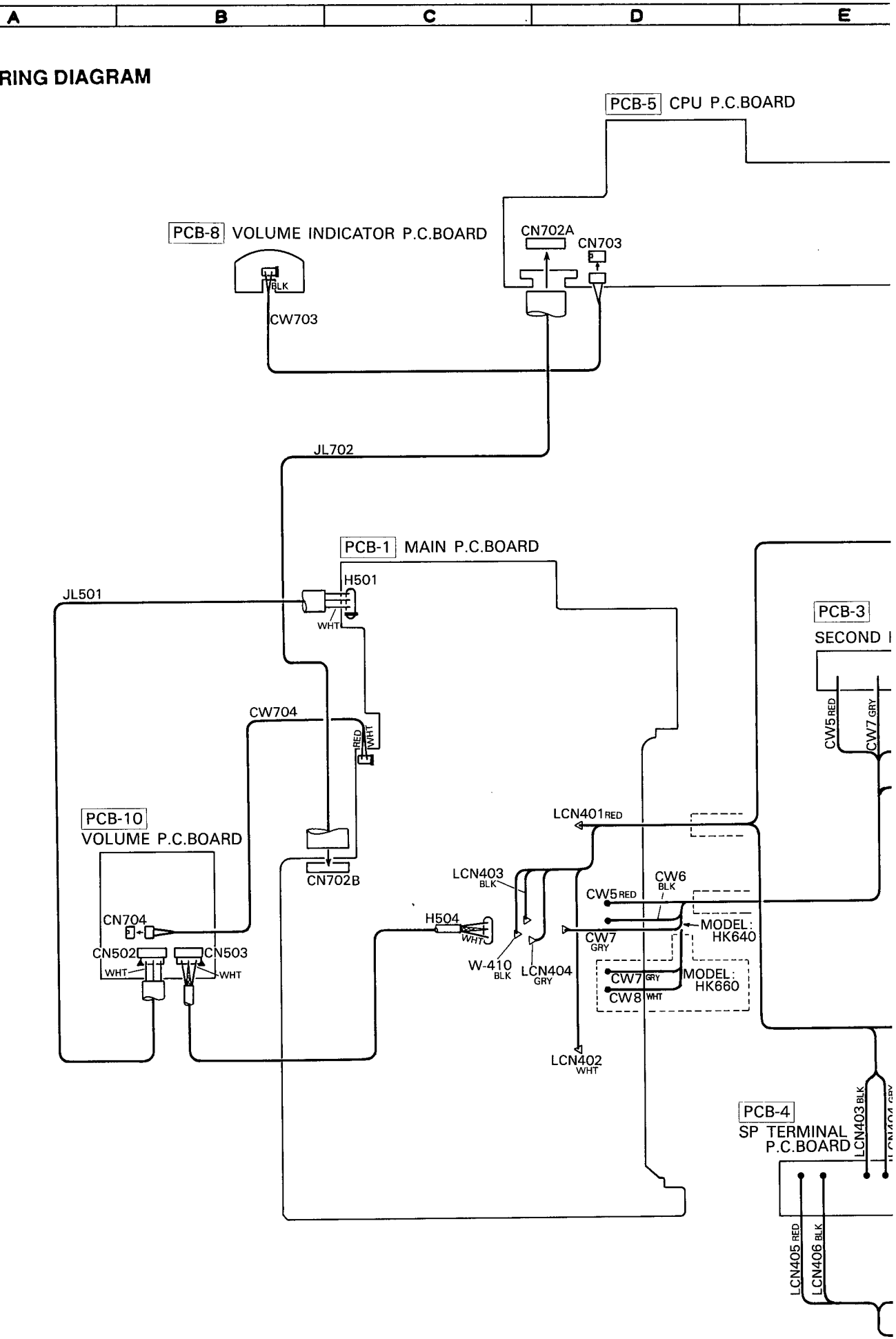

F

G

H

I

J

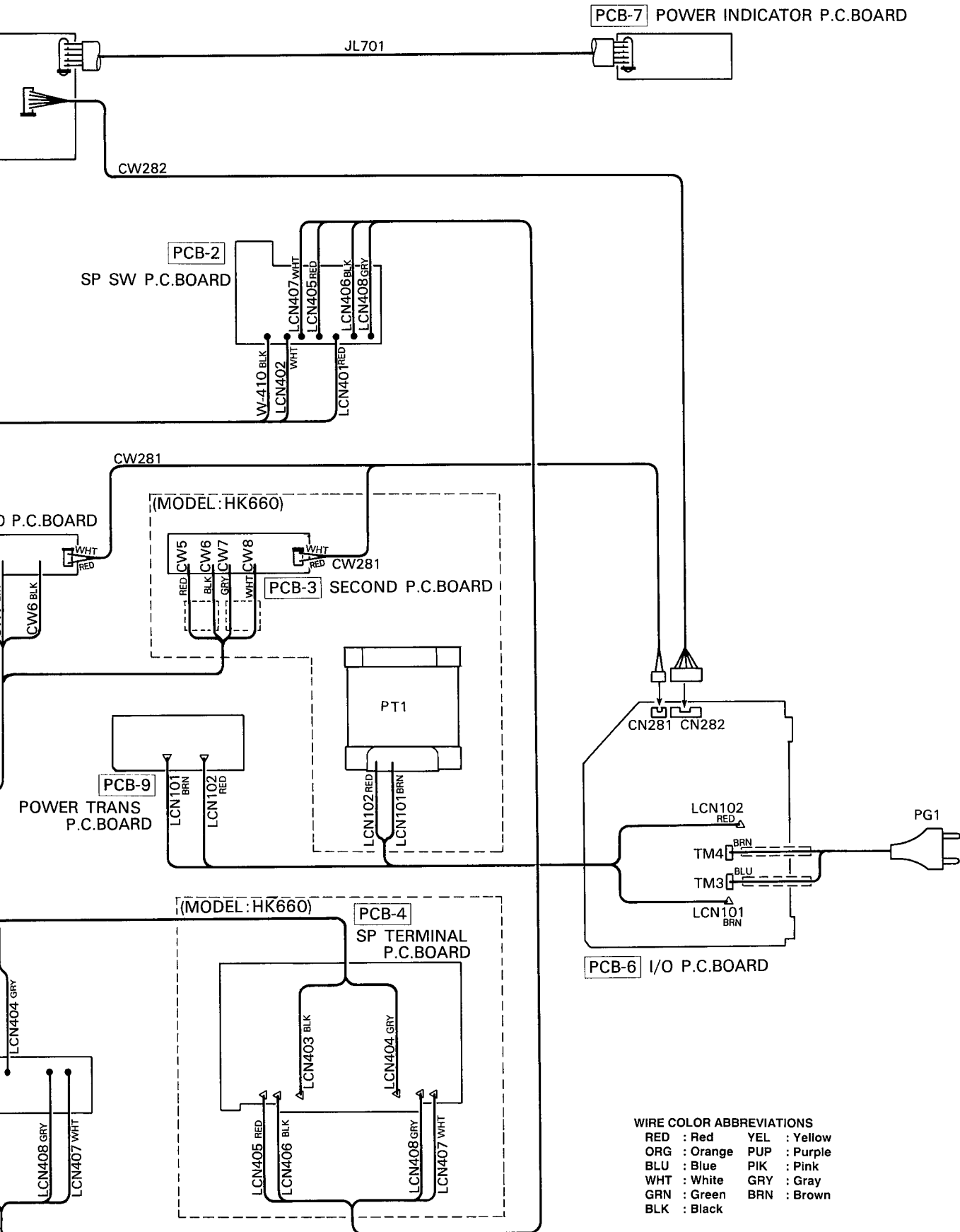

### PH600 Phono PCB Option:

When this option is installed, MM or MC turntables can be connected to the RCA jacks on the Phono PCB. To use the Phono input, the function selector switch on the front panel must be set to the AUX position. Please note that when the Phono PCB option is installed, signal wires shall not be connected to the AUX RCA connectors. Signal applied to the AUX input with the Phono option installed, will be attenuated and may be distorted. Installation of Optional Phono PCB (PH600):

(Please re-print the information from information sheet you already prepared.)

#### HOW TO INSTALL

- ① Remove 6 screws and then remove the Top Cover.
- ② Remove a screw and a rivet and then remove the plate.

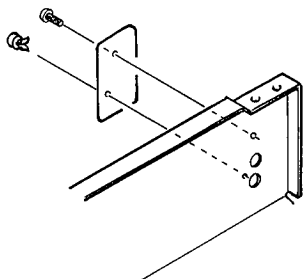

- ③ Secure PH600 with a rivet removed from the plate.

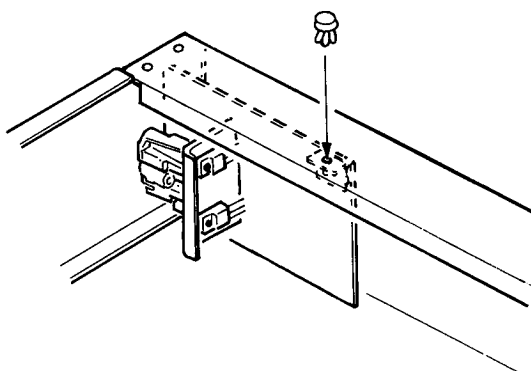

- ④ Secure the screw removed from the plate and the ground terminal screw (included).

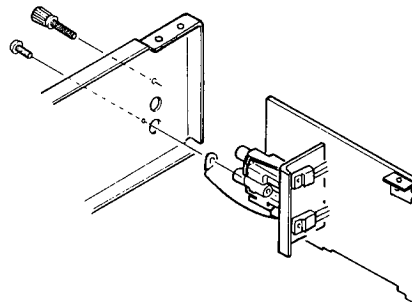

- ⑤ Connect the 2 cables precisely as shown in the illustration.

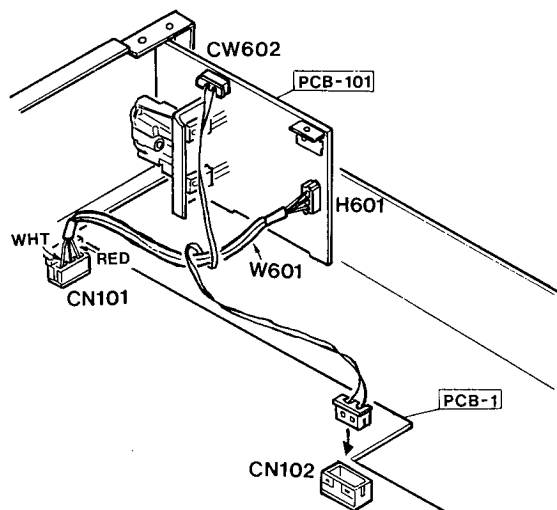

#### GENERAL UNIT

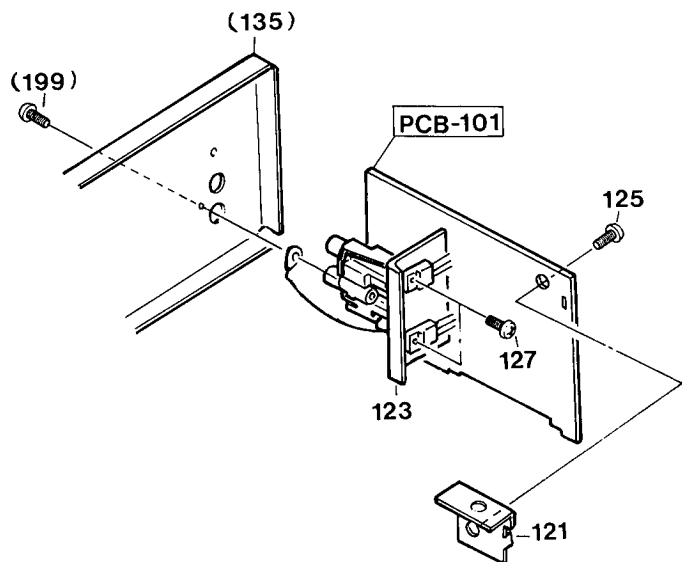

#### GENERAL UNIT PARTS LIST

Ser. No.	Ref. No.	Part No.	Description
121	2219-8350		METAL FITTING
123	2222-7179		HEAT SINK
125	2347-R0130062		SCREW, BND T+ (3×6 mm)
127	2347-R0130082		SCREW, BND T+ (3×8 mm) (×2)

## P.C. BOARD

The PH600 is set at the factory as a high gain MC EQ amplifier. It can easily be converted to a MM EQ amplifier by making these changes:

1. Remove L701 and L702 (bare wires with ferrite beads),
2. Remove C701 and C702 (0.022 $\mu$ F capacitors, marked 223J),
3. Remove R715 and R716 (1k $\Omega$  resistors), and
4. Add 2 jumper wires (JP) along the dotted lines on the circuit board (near the location of R715 and R716).

PCB-101 MC VERSION (Factory setting)

PCB-101 MM VERSION

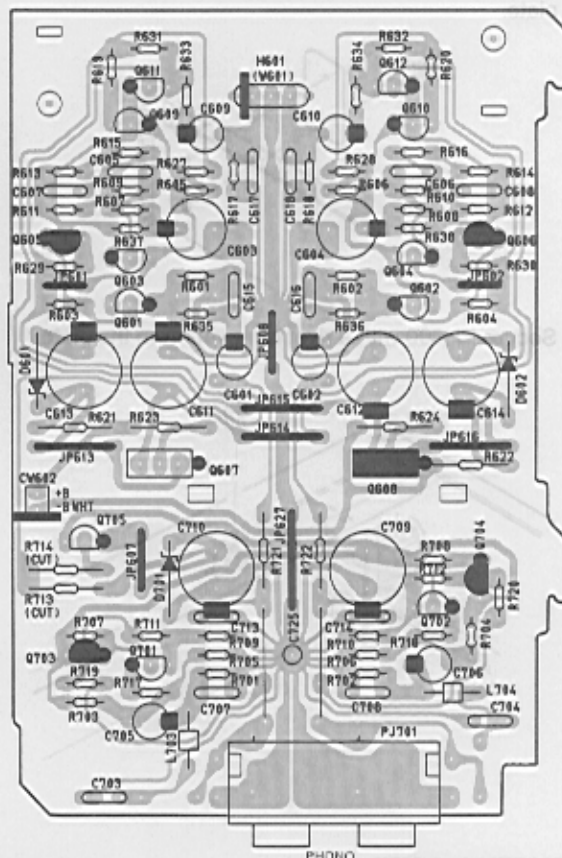
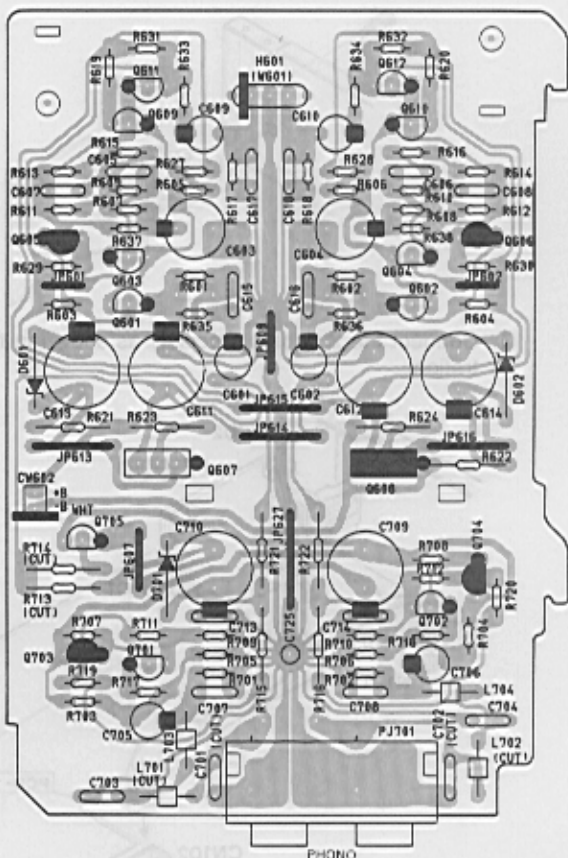

L701, L702 → Delete

C701, C702 → Delete

R715, R716 → Delete

Add 2 jumper wires (JP) along dotted lines

## WIRING DIAGRAM

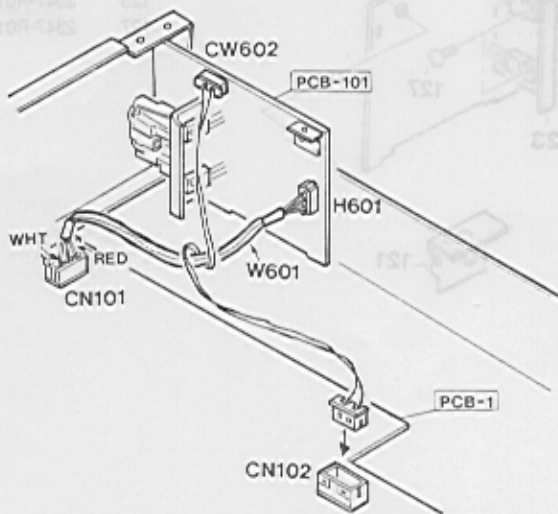

SCHEMATIC DIAGRAM

MODEL: HK610 36.9V  
 HK620 38.4V  
 HK640 43.5V  
 HK660 46.5V  
 HK680 51.7V  
 CW602

MODEL: HK610 -36.9V  
 HK620 -38.4V  
 HK640 -43.5V  
 HK660 -46.5V  
 HK680 -51.7V

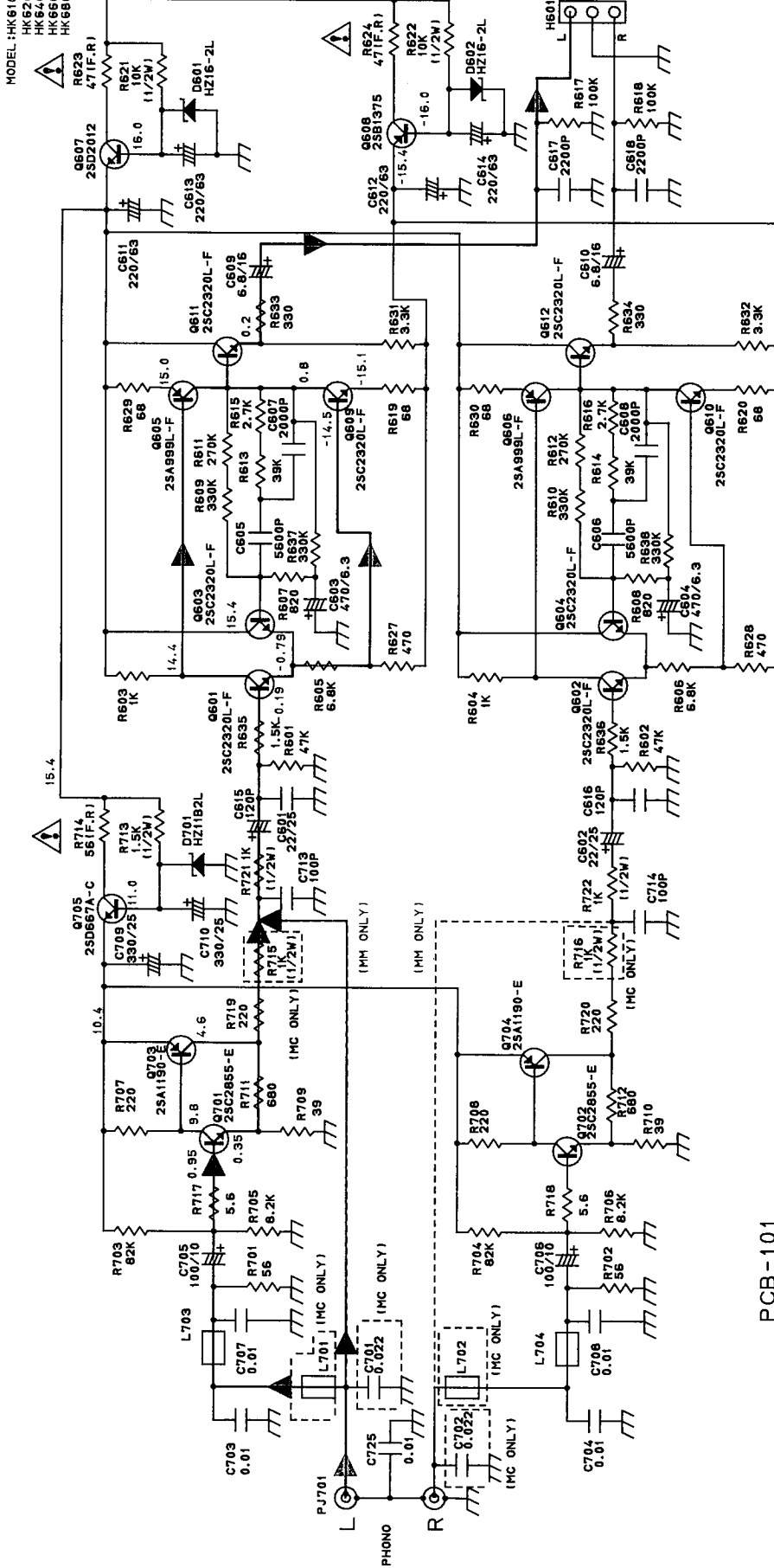

Page 17  
 and 18

Page 17  
 and 18

PCB-101  
 PHONO P.C. BOARD

## ELECTRICAL PARTS LIST

Ser. No.	Ref. No.	Part No.	Description	Ser. No.	Ref. No.	Part No.	Description
<b>PCB-101 PHONO P.C. BOARD</b>							
<b>CAPACITORS</b>							
400	C601	5345-S29DM226	CAP, MINI ELE 22U/25V	417	R638	5178-334381	RES, MTL 1/6P 330K
400	C602	5345-S29DM226	CAP, MINI ELE 22U/25V	450	R701	5130-R010J560	RES, CBN 1/6P 56
401	C603	5345-S29AD477	CAP, MINI ELE 470U/6.3V	450	R702	5130-R010J560	RES, CBN 1/6P 56
401	C604	5345-S29AD477	CAP, MINI ELE 470U/6.3V	456	R703	5130-R010J823	RES, CBN 1/6P 82K
402	C605	5359-5625851	CAP, PPP 5600P	456	R704	5130-R010J823	RES, CBN 1/6P 82K
402	C606	5359-5625851	CAP, PPP 5600P	451	R705	5130-R010J822	RES, CBN 1/6P 8.2K
403	C607	5359-2025851	CAP, PPP 2000P	451	R706	5130-R010J822	RES, CBN 1/6P 8.2K
403	C608	5359-2025851	CAP, PPP 2000P	458	R707	5130-R010J221	RES, CBN 1/6P 220
404	C609	5345-685C0951	CAP, MINI ELE 6.8U/16V	458	R708	5130-R010J221	RES, CBN 1/6P 220
404	C610	5345-685C0951	CAP, MINI ELE 6.8U/16V	452	R709	5178-390381	RES, MTL 1/6P 39
405	C611	5345-S25GM227	CAP, MINI ELE 220U/63V	452	R710	5178-390381	RES, MTL 1/6P 39
405	C612	5345-S25GM227	CAP, MINI ELE 220U/63V	453	R711	5178-681381	RES, MTL 1/6P 680
405	C613	5345-S25GM227	CAP, MINI ELE 220U/63V	453	R712	5178-681381	RES, MTL 1/6P 680
405	C614	5345-S25GM227	CAP, MINI ELE 220U/63V	454	R713	5130-R030J152	RES, CBN 1/2P 1.5K
406	C615	5359-1215851	CAP, PPP 120P	457	△ R714	5102-5604713	RES, FUSE 56
406	C616	5359-1215851	CAP, PPP 120P	459	R715	5130-R030J102	RES, CBN 1/2P 1K
430	C617	5359-2225851	CAP, PPP 2200P	459	R716	5130-R030J102	RES, CBN 1/2P 1K
430	C618	5359-2225851	CAP, PPP 2200P	440	R717	5130-R010J5R6	RES, CBN 1/6P 5.6
441	C701	5359-S010J223	CAP, PPP .022U	440	R718	5130-R010J5R6	RES, CBN 1/6P 5.6
441	C702	5359-S010J223	CAP, PPP .022U	458	R719	5130-R010J221	RES, CBN 1/6P 220
442	C703	5359-S010J103	CAP, PPP .01U	458	R720	5130-R010J221	RES, CBN 1/6P 220
442	C704	5359-S010J103	CAP, PPP .01U	459	R721	5130-R030J102	RES, CBN 1/2P 1K
443	C705	5345-S29BM107	CAP, MINI ELE 100U/10V	459	R722	5130-R030J102	RES, CBN 1/2P 1K
443	C706	5345-S29BM107	CAP, MINI ELE 100U/10V	<b>TRANSISTORS</b>			
442	C707	5359-S010J103	CAP, PPP .01U	409	Q601	5613-2320L(F)	XISTOR, NPN R
442	C708	5359-S010J103	CAP, PPP .01U	409	Q602	5613-2320L(F)	XISTOR, NPN R
444	C709	5345-S25DM337	CAP, MINI ELE 330U/25V	409	Q603	5613-2320L(F)	XISTOR, NPN R
444	C710	5345-S25DM337	CAP, MINI ELE 330U/25V	409	Q604	5613-2320L(F)	XISTOR, NPN R
438	C713	5359-S010K101	CAP, PPP 100P	410	Q605	5611-999L(F)	XISTOR, PNP R
438	C714	5359-S010K101	CAP, PPP 100P	410	Q606	5611-999L(F)	XISTOR, PNP R
439	C725	5359-S010J103	CAP, PPP .01U	411	Q607	5614-2012	XISTOR, NPN A
<b>RESISTORS</b>							
413	R601	5130-R010J473	RES, CBN 1/6P 47K	412	Q608	5612-1375	XISTOR, PNP A
413	R602	5130-R010J473	RES, CBN 1/6P 47K	426	Q609	5613-2320L(F)	XISTOR, NPN R
414	R603	5130-R010J102	RES, CBN 1/6P 1K	426	Q610	5613-2320L(F)	XISTOR, NPN R
414	R604	5130-R010J102	RES, CBN 1/6P 1K	426	Q611	5613-2320L(F)	XISTOR, NPN R
415	R605	5130-R010J682	RES, CBN 1/6P 6.8K	426	Q612	5613-2320L(F)	XISTOR, NPN R
415	R606	5130-R010J682	RES, CBN 1/6P 6.8K	447	Q701	5613-2855(E)	XISTOR, NPN R
416	R607	5178-821381	RES, MTL 1/6P 820	447	Q702	5613-2855(E)	XISTOR, NPN R
416	R608	5178-821381	RES, MTL 1/6P 820	448	Q703	5611-1190(E)	XISTOR, PNP R
417	R609	5178-334381	RES, MTL 1/6P 330K	448	Q704	5611-1190(E)	XISTOR, PNP R
417	R610	5178-334381	RES, MTL 1/6P 330K	449	Q705	5614-667A(C)	XISTOR, NPN A
418	R611	5178-274381	RES, MTL 1/6P 270K	<b>DIODES</b>			
418	R612	5178-274381	RES, MTL 1/6P 270K	408	D601	5635-HZ16-2L	DIODE, ZENER
419	R613	5178-393381	RES, MTL 1/6P 39K	408	D602	5635-HZ16-2L	DIODE, ZENER
419	R614	5178-393381	RES, MTL 1/6P 39K	445	D701	5635-HZ11B2L	DIODE, ZENER
420	R615	5178-272381	RES, MTL 1/6P 2.7K	<b>MISCELLANEOUS</b>			
420	R616	5178-272381	RES, MTL 1/6P 2.7K	407	CW602	4163-S0202201	CONNECTOR W/W, 2 PIN
421	R617	5130-R010J104	RES, CBN 1/6P 100K	446	PJ701	4489-04006002	PIN JACK, MLT, PHONO
421	R618	5130-R010J104	RES, CBN 1/6P 100K	455	L701	5597-3	CORE, BEADS
428	R619	5130-R010J680	RES, CBN 1/6P 68	455	L702	5597-3	CORE, BEADS
428	R620	5130-R010J680	RES, CBN 1/6P 68	455	L703	5597-3	CORE, BEADS
422	R621	5130-R030J103	RES, CBN 1/2P 10K	455	L704	5597-3	CORE, BEADS
422	R622	5130-R030J103	RES, CBN 1/2P 10K	431	W601	4142-00151241	SHLD WIRE, 2C
423	△ R623	5102-4705116	RES, FUSE 47	437		4211-4	LUG, C725
423	△ R624	5102-4705116	RES, FUSE 47	432		2240-Z031	HOLDER, H601(W601)
429	R627	5130-R010J471	RES, CBN 1/6P 470	<b>GRASSIS MISCELLANEOUS</b>			
429	R628	5130-R010J471	RES, CBN 1/6P 470	<b>MISCELLANEOUS</b>			
428	R629	5130-R010J680	RES, CBN 1/6P 68	460		4214-168	TERMINAL, GND
428	R630	5130-R010J680	RES, CBN 1/6P 68	<b>PACKING UNIT PARTS LIST</b>			
427	R631	5130-R010J332	RES, CBN 1/6P 3.3K	<b>MISCELLANEOUS</b>			
427	R632	5130-R010J332	RES, CBN 1/6P 3.3K	107		1111-1780J152	OWNER GUIDE
424	R633	5130-R010J331	RES, CBN 1/6P 330	109		1231-00401	GIFT BOX
424	R634	5130-R010J331	RES, CBN 1/6P 330	113		1241-00501	POLYETHY BAG, SET
433	R635	5130-R010J152	RES, CBN 1/6P 1.5K	115		1756-00307	LABEL, OPTIONAL PHONO BOARD
433	R636	5130-R010J152	RES, CBN 1/6P 1.5K				
417	R637	5178-334381	RES, MTL 1/6P 330K				



# SCHEMATIC DIAGRAM (1)

PCB-5 CPU P.C. BOARD

CN'

Page 17  
and 18



PCB-7  
POWER IND  
P.C. BOARD

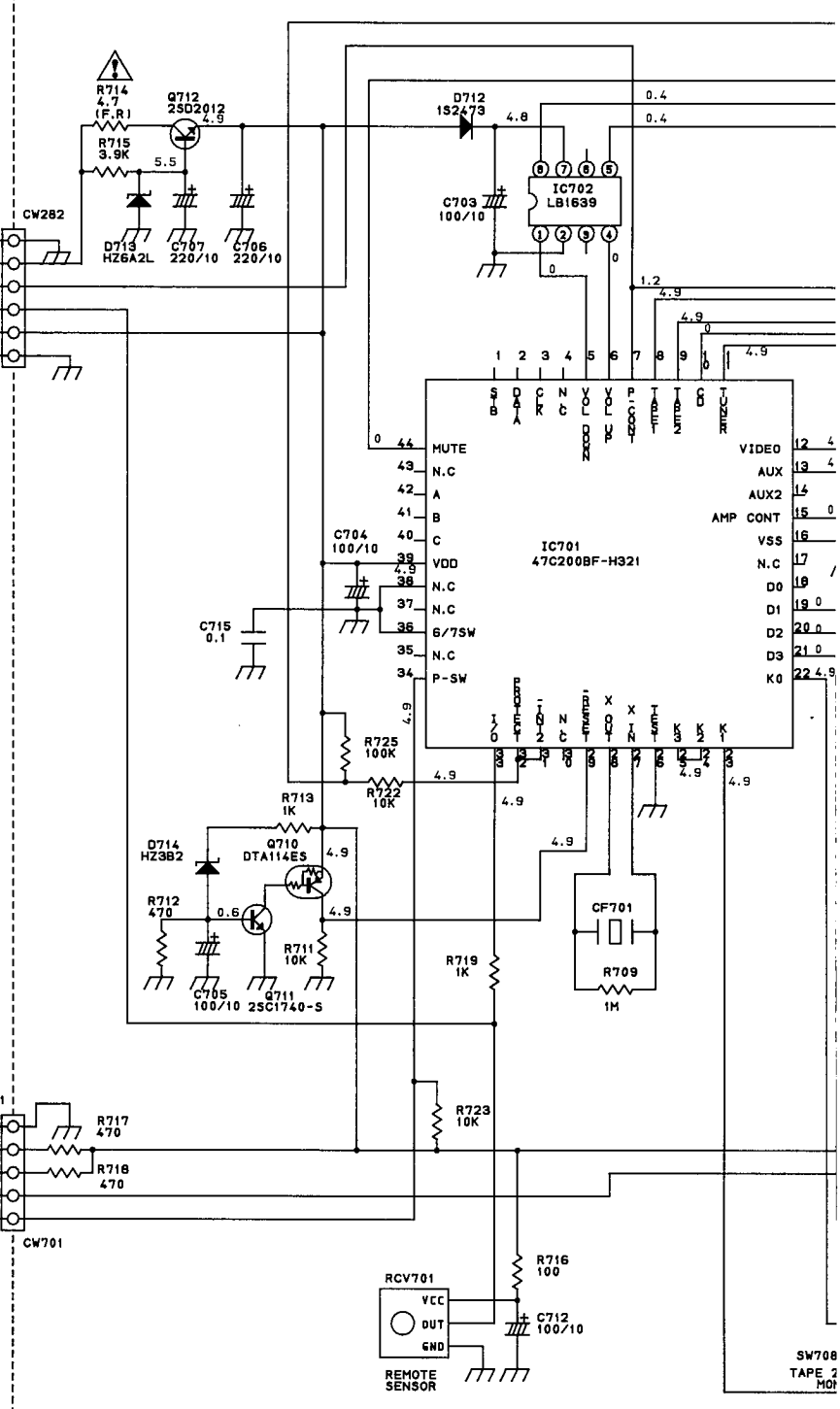
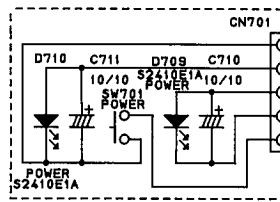

SW708  
TAPE 2  
MOT

Page 17 and 18

J  
9  
E

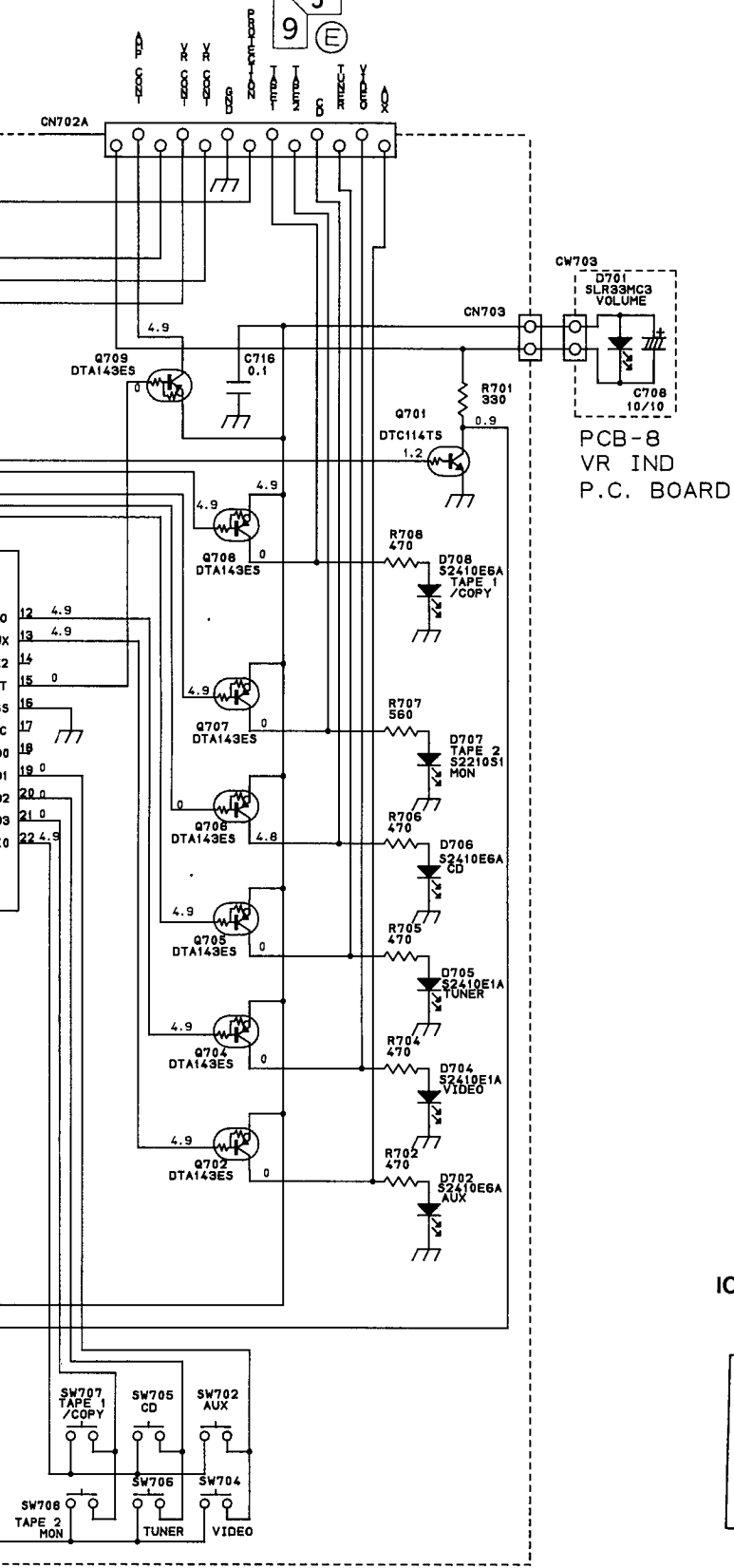

IC702: LB1639 Volume Motor Driver

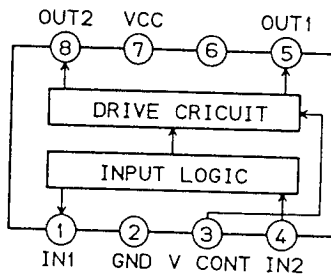

SCHEMATIC DIAGRAM (2)

MODEL:HK640

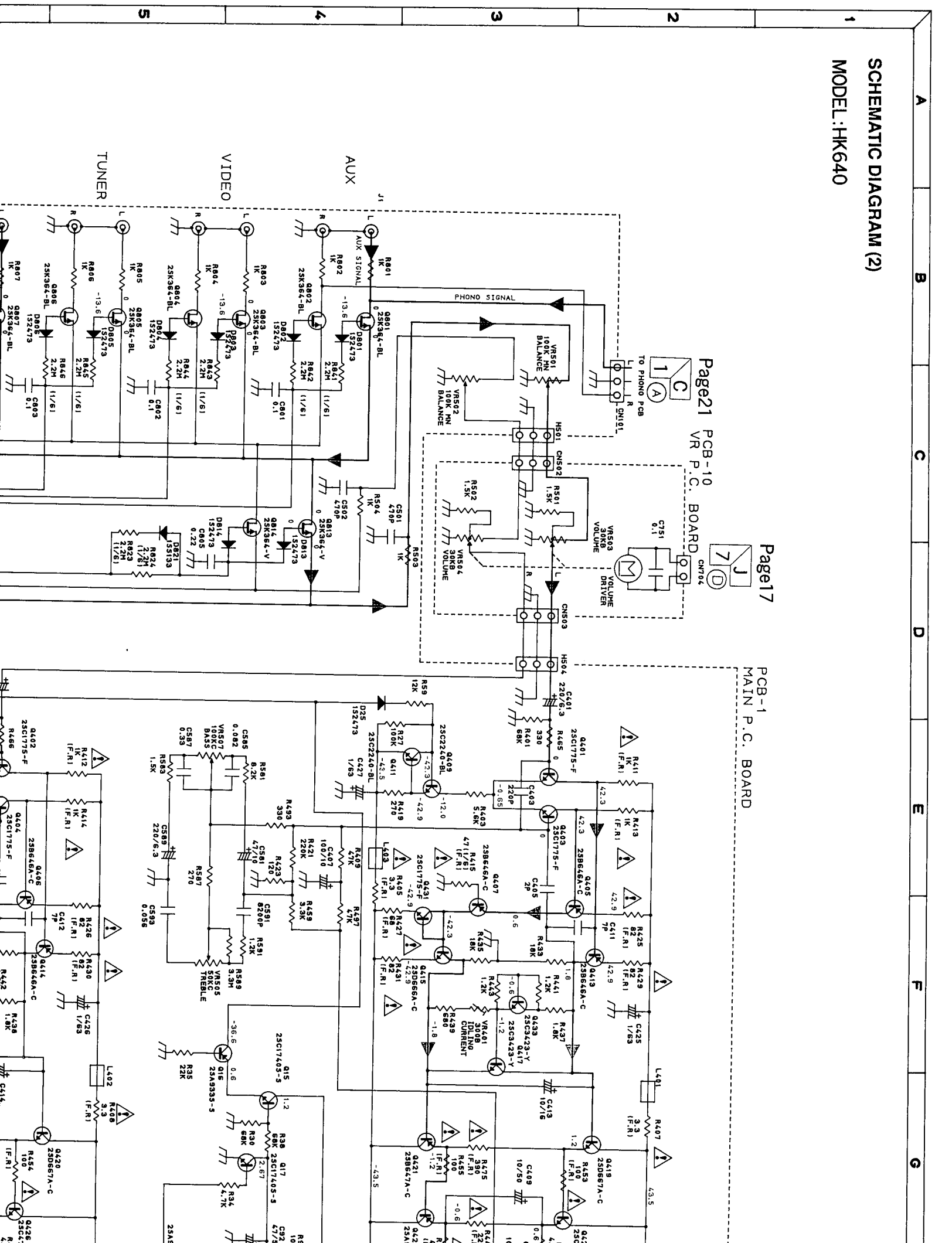

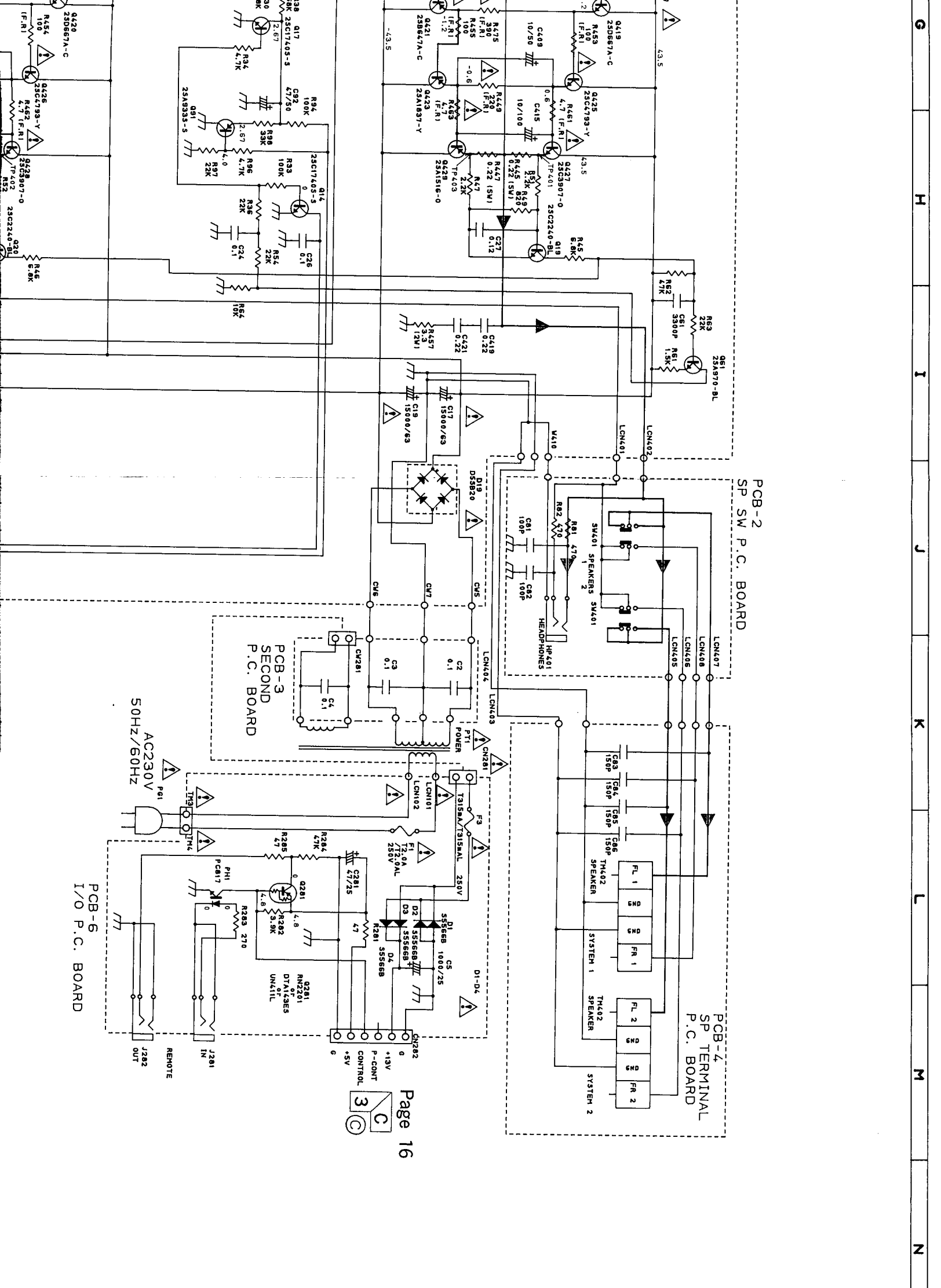

PCB-2  
SP SW P.C. BOARD

PCB-4  
SP TERMINAL  
P.C. BOARD

PCB-3  
SECOND  
P.C. BOARD

PCB-6  
I/O P.C. BOARD

AC230V  
50Hz/60Hz

