

The Harman Kardon Model HD7450 COMPACT DISC PLAYER

Manual 160A

Technical Manual

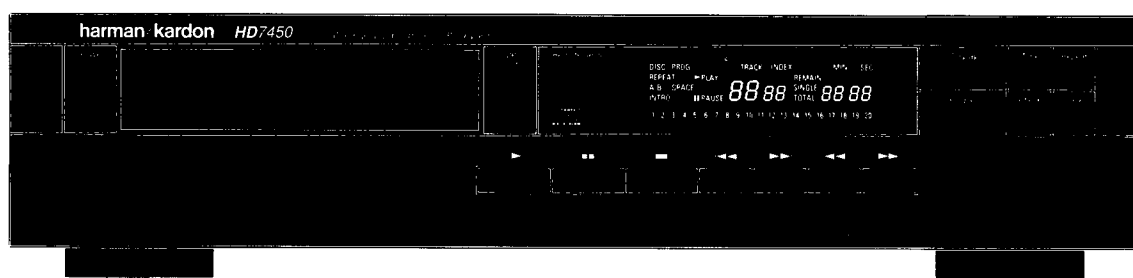

The following marks found in the parts list of this manual identify the models as follows.

- BK : North America area model Black version
- I : International model
- IB : International model Black version
- BB : Australia model Black version
- WB : Asia / Oceania model Black version

harman/kardon

240 Crossways Park West, Woodbury, N. Y. 11797
1112-3152160A3 P-089008 2000 Printed in Japan

CLASS 1 LASER PRODUCT

Product complies with DHHS rules CFR subchapter J part 1040:10 at date of manufacture.

DANGER—invisible laser radiation when open and interlock failed or defeated. Avoid direct exposure to the beam.

CAUTION—use of all controls, adjustments or performance of procedures other than those specified herein may result in hazardous radiation exposure.

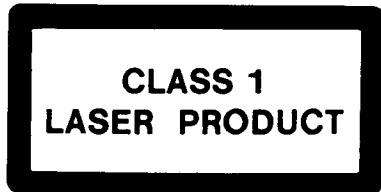
**Be Careful of the Laser Pickup**

Although you cannot see it from the outside, a laser pickup is located under the disc tray and a precision lens is built in it.

Since the laser pickup, including the lens element, is especially sensitive to dust, keep the disc tray closed when not in use. Also do not put your hand inside the unit.

ADVARSEL:

Usynlig laserstråling ved åbning når sikkerhedsafbrydere er ude af funktion. Undgå udsættelse for stråling.

VAROITUS!

Laite sisältää laserdiodin, joka lähettää näkymätöntä silmille vaarallista lasersäteilyä.

SPECIFICATION

| | |
|---------------------------------|----------------------------------------------------------------------------------|
| System | : Compact Disc Digital Audio |
| D/A Converter | : Linear, Pulse Width Modulated Bit Stream, Clock Rate: 33.8688MHz (33,868.8KHz) |
| Signal Detection | : 3-Beam Semiconductor Optical Laser Pickup |
| Error Correction | : CIRC System |
| Low Level Linearity | : +/-1.0dB @-90dB |
| Frequency Response | : 4Hz to 20kHz +0dB/-1.5dB |
| Total Harmonic Distortion (THD) | : 0.003% |
| Dynamic Range | : 97dB |
| Signal to Noise Ratio | : 103dB |
| Channel Separation | : 93dB |
| Line Output Level/Impedance | : 2.0V @ 10kΩ |

Power Supply

| | |
|--------------------------|------------------------------------------------|
| U.S.A. and Canada models | : AC120V, 60Hz |
| International model | : AC220/240V, 50/60Hz |
| Japan model | : AC100V, 50/60Hz |
| Power Consumption | : 15Watts |
| Dimensions | : 17-3/8" x 4" x 14" 443mm x 103mm x 356 mm |
| Weight | : 11.5lbs./5.2kg |

Specifications and components subject to change without notice. Overall performance will be maintained or improved.

Adjustment of this unit requires following measuring instruments and jigs.

- Oscilloscope (3 or more modes, 100MHz, input Select DC range) 1740A
- Test Disc: EIAJ CD-1

SAFETY PRECAUTIONS

Before returning an instrument to the customer, always make a safety check of the entire instrument, including, but not limited to, the following items:

- a. Be sure that no built-in protective devices are defective and/or have been defeated during servicing.
- (1) Protective shields are provided to protect both the technician and the customer. Correctly replace all missing protective shields, including any removed for servicing convenience.
 - (2) When reinstalling the chassis and/or other assembly in the cabinet, be sure to put back in place all protective devices, including, but not limited to, nonmetallic control knobs, insulating fishpapers, adjustment and compartment covers/shields, and isolation resistor/capacitor networks.

Do not operate this instrument or permit it to be operated without all protective devices correctly installed and functioning.

- b. Be sure that there are no cabinet openings through which an adult or child might be able to insert their fingers and contact a hazardous voltage. Such openings include, both are not limited to, excessively wide cabinet ventilation slots, and an improperly fitted and/or incorrectly secured cabinet back over.

- c. **Leakage Current Hot Check** — With the instrument completely reassembled, plug the AC line cord directly into a 120V AC outlet. (Do not use an isolation transformer during this test.) Use a leakage current tester or a metering system that complies with American National Standards Institute (ANSI) C101.1 "Leakage Current for Appliances" and Underwriters Laboratories (UL) 1270, (34.6). With the instrument AC switch first in the ON position and then in the OFF position, measure from a known earth ground (metal waterpipe, conduit, etc.) to all exposed metal parts of the instrument (antennas, handle bracket, metal cabinet, screwheads, metallic overlays, control shafts, etc.), especially any exposed metal parts that offer an electrical return path to the chassis. Any current measured must not exceed 0.5 milliamp. Reverse the instrument power cord plug in the outlet and repeat test. **ANY MEASUREMENTS NOT WITHIN THE LIMITS SPECIFIED HEREIN INDICATE A POTENTIAL SHOCK HAZARD THAT MUST BE ELIMINATED BEFORE RETURNING THE INSTRUMENT TO THE CUSTOMER.**

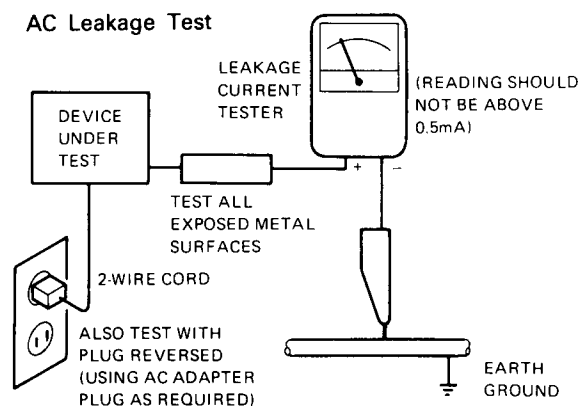

d. Insulation Resistance Test

- (1) Unplug the power supply cord and connect a jumper wire between the two prongs of the plug.
- (2) Turn on the power switch of the instrument.
- (3) Measure the resistance with an ohmmeter between the jumpered AC plug and each **exposed metallic** cabinet part on the instrument, such as screwheads, antenna, control shafts, handle brackets, etc. The reading should be as shown below. If it is not within the limits specified, there is the possibility of a shock hazard, and the instrument must be repaired and rechecked before it is returned to the customer.

e. Insulation Resistance Test Cold Check

- (1) Unplug the power supply cord and connect a jumper wire between the two prongs of the plug.
- (2) Turn on the power switch of the instrument.
- (3) Measure the resistance with an ohmmeter between the jumpered AC plug and each **exposed metallic** cabinet part on the instrument, such as screwheads, antenna, control shafts, handle brackets, etc. When the exposed metallic part has a return path to the chassis, the reading should be between 1 and 5.2 Megohm. When there is no return path to the chassis, the reading must be "infinite". If it is not within the limits specified, there is the possibility of a shock hazard, and the instrument must be repaired and rechecked before it is returned to the customer.

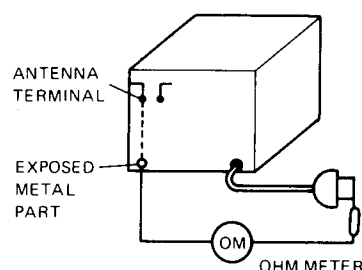

PRODUCT SAFETY NOTICE

Some electrical and mechanical parts have special safety related characteristics which are often not evident from visual inspection, nor can the protection they give necessarily be obtained by replacing them with components rated for higher voltage, wattage, etc. Parts that have special safety characteristics are identified by shading, by (▲) on schematics and parts listed. Use of a substitute replacement that does not have the same safety characteristics as the recommended replacement part might create shock, fire, and/or other hazards. Products Safety is under review continuously and new instructions are issued whenever appropriate.

SERVICING PRECAUTIONS

CAUTION: Before servicing instruments covered by this manual and its supplements, read and follow the SAFETY PRECAUTIONS on this page.

NOTE: If unforeseen circumstances created conflict between the following servicing precautions and any of the safety precautions, **always follow the safety precautions.** Remember: Safety First.

General Servicing Precautions

- a. Always unplug the instrument AC power cord from the AC power source before:
 - (1) Removing or reinstalling any component, circuit board, module, or any other instrument assembly.
 - (2) Disconnecting or reconnecting any instrument electrical plug or other electrical connection.
 - (3) Connecting a test substitute in parallel with an electrolytic capacitor in the instrument.
Caution: A wrong part substitution or incorrect polarity installation of electrolytic capacitors may result in an explosion hazard.
- b. Do **not** defeat any plug/socket B+ voltage interlocks with which instruments covered by this manual might be equipped.
- c. Do **not** apply AC power to this instrument and/or any of its electrical assemblies unless all solid-state device heat sinks are correctly installed.
- d. Always connect a test instrument's ground lead to the instrument chassis ground before connecting the test instrument positive lead. Always remove the test instrument ground lead last.

NOTE: Refer to Safety Precautions on Page 3.

- (1) The service precautions are indicated or printed on the cabinet, chassis or components. When servicing, follow the printed or indicated service precautions and service materials.
- (2) The Components used in the unit has a specified flammability and dielectric strength. When replacing any components, use components which has the same ratings. Components marked (Δ) in the circuit diagram are important for safety or for the characteristics of the unit. Always replace with the appointed components.
- (3) An insulation tube or tape is sometimes used and some components are raised above the printed wiring board for safety. The internal wiring is sometimes clamped to prevent contact with heating components. Install them as they were.
- (4) After servicing, always check that the removed screws, components and wiring have been installed correctly and that the portion around the service part have not been damaged and so on. Further check the insulation between the blades of attachment plug and accessible conductive parts.

Insulation Checking Procedure

Disconnect the attachment plug from the AC outlet and turn the power on. Connect the insulation resistance meter (500V) to the blades of the attachment plug. The insulation resistance between the each blade of the attachment plug and accessible conductive parts (Note 1) should be more than 1M-ohm.

Note 1: Accessible Conductive Parts including Metal panels, Output jacks, etc.

ELECTROSTATICALLY SENSITIVE (ES) DEVICES

Some semiconductor (solid state) devices can be damaged easily by static electricity. Such components commonly are called Electrostatically Sensitive (ES) Devices. Examples of typical ES devices are integrated circuits and some fieleffect transistors and semiconductor "chip" components. The following techniques should be used to help reduce the incidence of component damage caused by static electricity.

1. Immediately before handling any semiconductor component or semiconductor-equipped assembly, drain off any electrostatic charge on your body by touching a known earth ground. Alternatively, obtain and wear a commercially available discharging wrist strap device, which should be removed for potential shock reasons prior to applying power to the unit under test.
2. After removing an electrical assembly equipped with ES devices, place the assembly on a conductive surface such as aluminum foil, to prevent electrostatic charge buildup or exposure of the assembly.
3. Use only a grounded-tip soldering iron to solder or unsolder ES devices.
4. Use only an anti-static solder removal device. Some solder removal devices not classified as "anti-static" can generate electrical charges sufficient to damage ES devices.
5. Do not use freon-propelled chemicals. These can generate electrical charge sufficient to damage ES devices.
6. Do not remove a replacement ES device from its protective package until immediately before you are ready to install it. (Most replacement ES devices are packaged with leads electrically shorted together by conductive foam, aluminum foil or comparable conductive material).
7. Immediately before removing the protective material from the leads of a replacement ES device, touch the protective material to the chassis or circuit assembly into which the device will be installed.
CAUTION: Be sure no power is applied to the chassis or circuit, and observe all other safety precautions.
8. Minimize bodily motions when handling unpackaged replacement ES devices. (Otherwise harmless motion such as the brushing together of your clothes fabric or the lifting of your foot from a carpeted floor can generate static electricity sufficient to damage an ES device).

CONTROLS AND FUNCTIONS

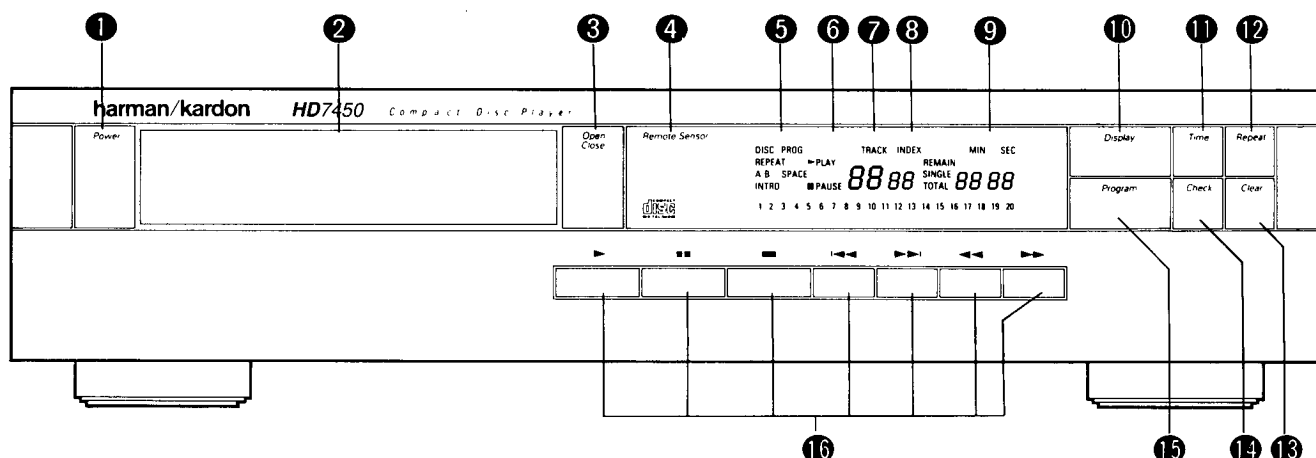
**1 POWER switch**

The POWER switch turns the unit on and off.

2 Compact disc drawer

Load a disc (full-size or 3-inch) into your compact disc player by placing it in this drawer with the label side up. Open and close the drawer using the OPEN/CLOSE button (3).

3 OPEN/CLOSE button

Press this button to open or close the compact disc drawer. The drawer will also close if you press the play button or push the drawer gently toward the chassis of the player; however, we recommend that you do not push the drawer.

4 REMOTE SENSOR

This area receives the signal from the remote control unit. Make sure this area of the front panel is kept free from dirt or other obstructions that might prevent proper reception of the infrared signal from the remote control.

5 FUNCTION indicator

DISC - This indicator lights when the disc drawer is open, and when a disc is loaded. It does not light when there is no disc inside.

REPEAT - When this indicator is lit, the unit is in REPEAT mode and will continuously repeat either the entire disc or the programmed sequence.

A-B - When this indicator is lit steadily, the unit is set to repeat a specified section of the disc (from A to B). When repeat indicator is lit, you have already programmed the starting point (point A) of a section, and the unit is waiting for you to program the ending point of the section (point B).

INTRO - When this indicator is lit, the unit is in INTRO SCAN mode and will play only the first 15 seconds of each selection on the disc or in the selected program.

PROG - When this indicator is lit, the unit is in PROGRAM mode, in which you can program a sequence of tracks in the order you'd like to hear them, then play back your programmed sequence.

SPACE - When this indicator is lit, the unit is in SPACE mode and will insert 4 seconds of space between tracks.

6 PLAYBACK mode

PLAY - This indicator is lit when the unit is playing a track.

PAUSE - This indicator is lit when the unit is in PAUSE mode (i.e., you have pressed PAUSE to temporarily stop playback).

7 TRACK indicator

When a disc is loaded but not playing, the TRACK indicator displays the total number of tracks on that disc. During playback, the indicator displays the number of the track currently being played. During programming, it displays the number of the track most recently selected.

8 INDEX indicator

Some discs that contain very long tracks may have those tracks subdivided into shorter sections. For example, a long classical piece may be divided into movements, each of which may have an index number. The INDEX indicator displays the number of the subdivision of a track currently being played. If the track has no subdivisions, the INDEX indicator will display a 1 during playback. During programming, the INDEX light goes out and the indicator displays the total number of tracks selected in the programmed sequence.

9 TIME indicator

When a disc is loaded but not playing, the TIME indicator displays the total amount of playback time on that disc. During playback, depending on the state of the TIME button (9), the indicator displays one of the following

- The time that has elapsed since the beginning of the current track.
- The time that remains on the currently selected track. The words REMAIN SINGLE will be displayed if the indicator is in this mode.
- The time that remains on either the entire disc or on the programmed selections. The words REMAIN TOTAL will be displayed if the indicator is in this mode. Note that if you have programmed more than 99 minutes in your selection, only dashes will appear in this mode.

10 DISPLAY button

This button turns the display on and off. When you turn the display off in PLAY mode, the entire display goes off. In PAUSE mode, most of the display goes off, but the track number is still displayed. In STOP mode, most of the display goes off, but the total number of tracks on the disc is still displayed. In some systems, turning the fluorescent display off may provide the purest possible sound quality during playback.

11 TIME button

During playback or programming, this button cycles through the three TIME display modes

- The time that has elapsed since the beginning of the current track.
- The time that remains on the currently selected track.
- The time that remains on either the entire disc or the programmed sequence.

12 REPEAT button

This button puts your compact disc player in and out of REPEAT mode. In REPEAT mode, the unit will continually play back either the entire disc or the programmed sequence of tracks. Press the button once to turn on REPEAT mode; press again to turn off REPEAT mode. When the unit is in REPEAT mode, the FUNCTION indicator (5) will display the word REPEAT.

13 CLEAR button

The CLEAR button removes tracks from your programmed sequence one by one starting with the last track entered. Each time you clear a track from the programmed sequence, that track's time is deleted from the total time displayed. This button is used only in PROGRAM mode.

14 CHECK button

When a disc is loaded but not playing (STOP mode), you can press the CHECK button to see the playback time of each track on the disc. Each time you press the CHECK button, the next track is displayed along with its playback time. When you have stepped sequentially through all the tracks on the disc, another press of the CHECK button displays the total playback time of the entire disc. In PROGRAM mode, the CHECK button displays the cumulative time of the tracks in the programmed sequence. That is, the first press displays the time of the first programmed track, the second press displays the cumulative playback time of the first and second tracks, and so on.

15 PROGRAM button

This button puts your compact disc player in and out of PROGRAM mode. Press the button once to turn on PROGRAM mode; press again to turn it off. In PROGRAM mode, you can program a set of tracks to play in any sequence. (For instructions on programming a sequence of tracks, see the Operations section of this manual.) When the unit is in PROGRAM mode, the FUNCTION indicator (5) will display the word PROG in red.

16 Playback controls

PLAY - ► The PLAY button starts playback of a track.
PAUSE - ■■ Pressing the PAUSE button temporarily stops playback. Pressing the PAUSE button again, or pressing PLAY, resumes playback at the precise point where playback left off.
STOP - ■■ The STOP button stops playback. When you press PLAY, playback will start either at the beginning of the disc or programmed sequence, or at any track you select.
SKIP BACK - ◀ Pressing this button once skips back to the beginning of the present track. If you are in PLAY mode, playback will resume. Holding the button down skips backward to the beginning of each preceding track until the first track on the disc is reached.
SKIP FORWARD - ▶ Pressing this button once skips forward to the beginning of the next track. If you are in PLAY mode, playback will resume. Holding the button down skips forward to the beginning of each subsequent track until the last track on the disc is reached.
SEARCH BACK - ◀◀ Holding down this button during playback reverses rapidly through the disc. This function is similar to the "Rewind" function on a tape deck.
SEARCH FORWARD - ▶▶ Holding down this button during playback speeds rapidly forward through the disc. This function is similar to the "Fast forward" function on a tape deck.

HD7450 Remote control

The remote control for the HD7450 provides the same functions found on the front panel of the compact disc player itself. In addition, the remote control provides some functions that are not found on the front panel.

The functions found on the remote control that are not found on the front panel are INTRO, A-B, INDEX, SPACE and the 1-10 and +10 keys. These five functions are described below (for other functions, see the descriptions above).

17 A-B button

This button puts your compact disc player in and out of A-B mode. In A-B mode, the unit will continually play back a "phrase" or section of your disc beginning at point A and ending at point B. (For instructions on repeating a section of a disc, see the Operations section of this manual.) When the unit is in A-B mode, the FUNCTION indicator (5) will display REPEAT A-B.

18 INTRO button

This button puts your compact disc player in and out of INTRO SCAN mode. When INTRO SCAN is on and you press PLAY, the unit plays only the first 15 seconds of each track before moving on to the next. Press the button once to turn on INTRO SCAN mode; press again to turn it off and stop the scanning. When the unit is in INTRO SCAN mode, the FUNCTION indicator (5) will display the word INTRO.

19 SPACE button

This button puts your compact disc player in and out of SPACE mode. Press the button once to turn on SPACE mode; press again to turn it off. In SPACE mode, the unit inserts 4 seconds of blank space between tracks. This is particularly useful if you are recording music from a compact disc onto a tape. Tape decks with a Music Search feature will be able to use the 4 seconds of space to correctly identify the beginning of each selection on the tape. When the unit is in SPACE mode, the FUNCTION indicator (5) will display the word SPACE.

20 INDEX buttons

Some discs contain long selections that may be subdivided into shorter sections (for example, operas). Just as the tracks are marked by the track number, these shorter sections may be marked by index numbers. When you have started playback of the desired track, you can use the INDEX UP and INDEX DOWN buttons to jump to a desired index selection. Each time you press an INDEX button, the INDEX indicator displays the next higher or lower index number. If you continue pressing the button until the indicated index number is higher than the actual number of index selections on the disc, playback will start from the nearest index selection.

21 Track selection buttons

This set of buttons (numbered 1 through 10 and +10) enables you to directly select the track you want to play. To select a track with a number higher than 10, press the +10 button, then press the button that will add up to the number of the track you want. For example, to select track 14, press +10, then press 4. If you select a track number that does not exist on your disc, the TRACK indicator will continue to display the number of the last track on the disc. When PROGRAM mode is off, pressing a track button plays the track you select. When PROGRAM mode is on, pressing a track button programs that track into your sequence.

REMOTE CONTROL

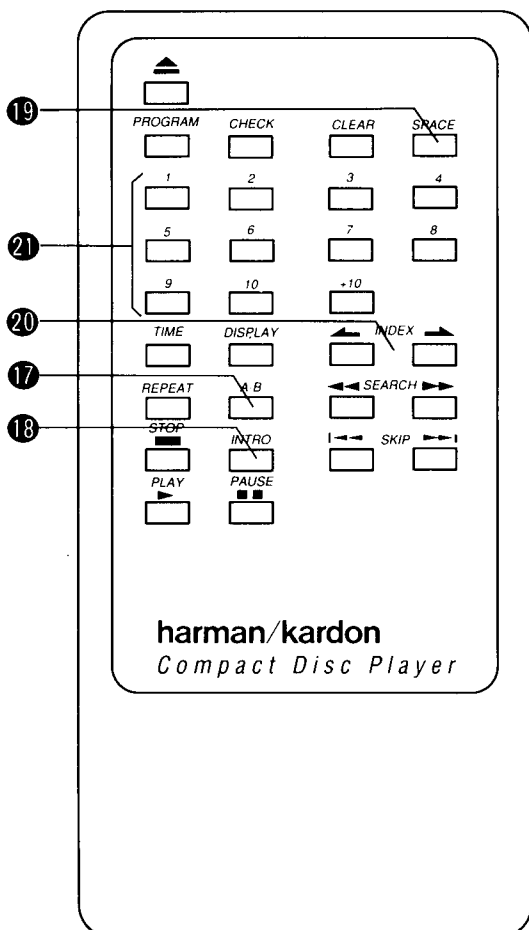

The remote control operates within a 30° angle of the remote sensor on the front panel of the unit. Make sure that the remote's front projection "lens" as well as the REMOTE SENSOR area on the front panel of the unit are kept free from dirt to ensure proper transmission and reception of the infrared beam. Also make sure that no objects (e.g., stereo cabinet doors, end tables) block the path from the remote control to the REMOTE SENSOR area.

Avoid using the remote control near fluorescent lamps, as they may shorten its operating range.

DISASSEMBLY PROCEDURES (REFER TO PAGES 36, 38 AND 39)

[1] CABINET TOP (123) REMOVAL

Remove 7 screws (A) and then remove the Cabinet Top (123).

[2] FRONT PANEL ASS'Y (AA) REMOVAL

1. Remove the Cabinet Top (123), referring to the previous step [1].
2. Disconnect the connectors with lead wires (LCN110, LCN111, LCN112, LCN116, LCN122 and LCN120) from connectors (CN109, CN110, CN111, CN112, CN116, CN122 and CN120) on the Main P. C. Board (PCB-1).
3. Remove 6 screws (B) and then remove the Front Panel Ass'y (AA) with the Front P. C. Board (PCB-2).
4. Remove 7 screws (C) and then remove the Front P. C. Board (PCB-2) from the Front Panel Ass'y (AA).

[3] MAIN P. C. BOARD (PCB-1) REMOVAL

1. Remove the Cabinet Top (123), referring to the previous step [1].
2. Disconnect the connector with lead wires (LCN110, LCN111, LCN112, LCN113, LCN114, LCN115, LCN116, LCN117, LCN120 and LCN122) from connectors (CN110, CN111, CN112, CN113, CN114, CN115, CN116, CN117, CN120 and CN122) on the Main P. C. Board (PCB-1).
3. Open the lid of connector (CN118) on the Main P. C. Board (PCB-1), then disconnect the jumper leads (JL1 and CN122).
4. Remove 8 screws (D) and then remove the Main P. C. Board (PCB-1).

[4] CD PLAYER MECHANICAL ASSEMBLY (120) REMOVAL

1. Remove the Cabinet Top (123), referring to the previous step [1].
2. Disconnect the connector with lead wires (LCN115, LCN114, LCN113 and LCN117) from connectors (CN115, CN114, CN113 and CN117) on the Main P. C. Board (PCB-1).
3. Remove 3 screws (E) and then remove the CD Player Mechanical Assembly (120) backward.

DISASSEMBLING THE CD PLAYER MECHANICAL ASSEMBLY

[5] DISC TRAY (16) REMOVAL

1. Remove the Cabinet Top (123), referring to the previous step [1].
2. Connect the Power cord and turn on the power by pressing the Power switch.
3. Open the Disc Tray (16) by pressing the Open/Close button.
4. With the Disc Tray (16) opened as it is, pull out the power plug.
5. Push the Disc Tray (16) by hand to slide it in once.
6. Loosen the 2 screws (F) and then slide out the Disc Tray (16) by hand.

[6] OPTICAL PICK-UP (52) REMOVAL

1. Remove the CD Player Mechanical Assembly (120), referring to the previous step [4].
2. Remove 4 screws (G) and then remove the Disc Motor Ass'y (63) with Pick-up, Slide Motor and etc.
3. Remove 2 screws (H) and then remove the Gears (59 and 60).
4. Remove the 2 screws (I) and then remove the Shaft Clamps (62), then remove the Pick-up (52) with shaft.

[7] SLIDE MOTOR (57) REMOVAL

1. Remove the Gears (59 and 60), referring to the previous step [6]-3.
2. Unsolder the terminal of Disc and Slide Motors, then remove the Motor P. C. Board (65).
3. Remove 2 screws (J) and then remove the Slide Motor (57).

POWER CORD REPLACEMENT (FOR SERVICE ENGINEERS OTHER THAN NORTH AMERICA)

In order to prevent fire or shock hazard when replacing the power cord, follow the procedure below to replace the part with the standard supply parts.

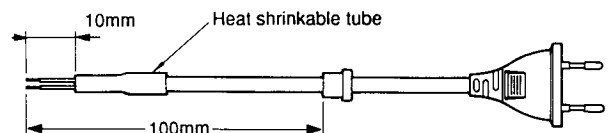
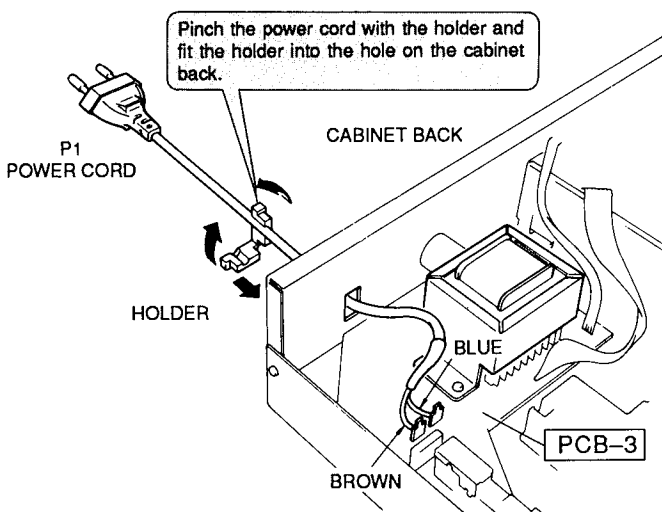

ADJUSTMENT PROCEDURE

1. Instruments required

- DC voltmeter
- Oscilloscope (3 or more modes, 100 MHz, input select DC range)
- Jitter meter
- Test disc: EIAJ CD-1

2. Adjustment points

- 2-1 Adjusting screw layout for CD player mechanical assembly.

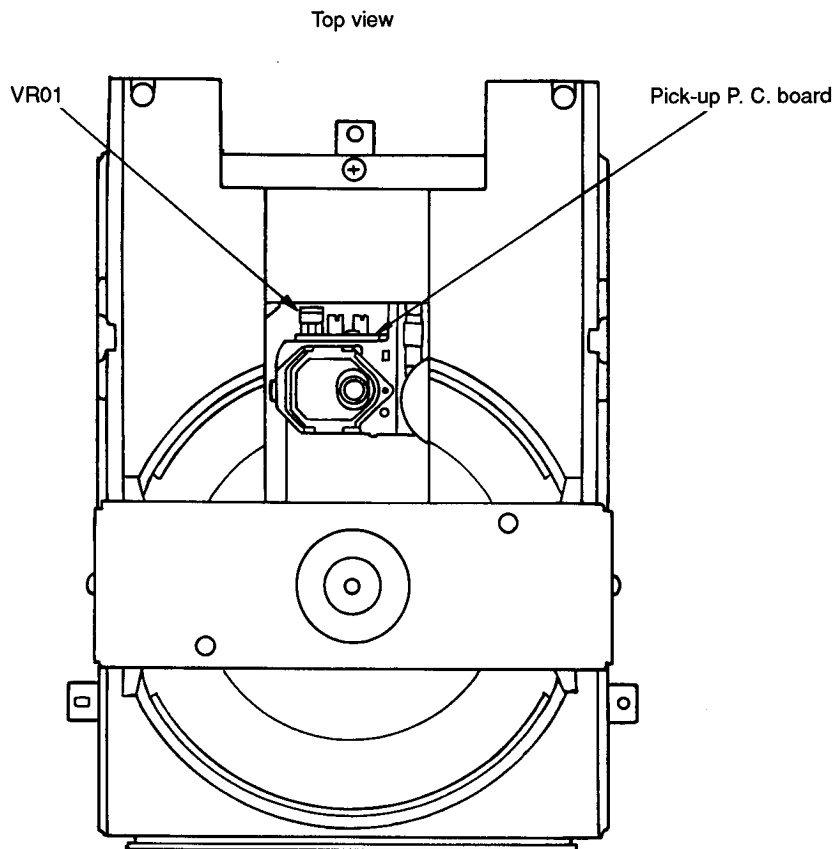

2-2 VR and test point layout for main P.C. board.

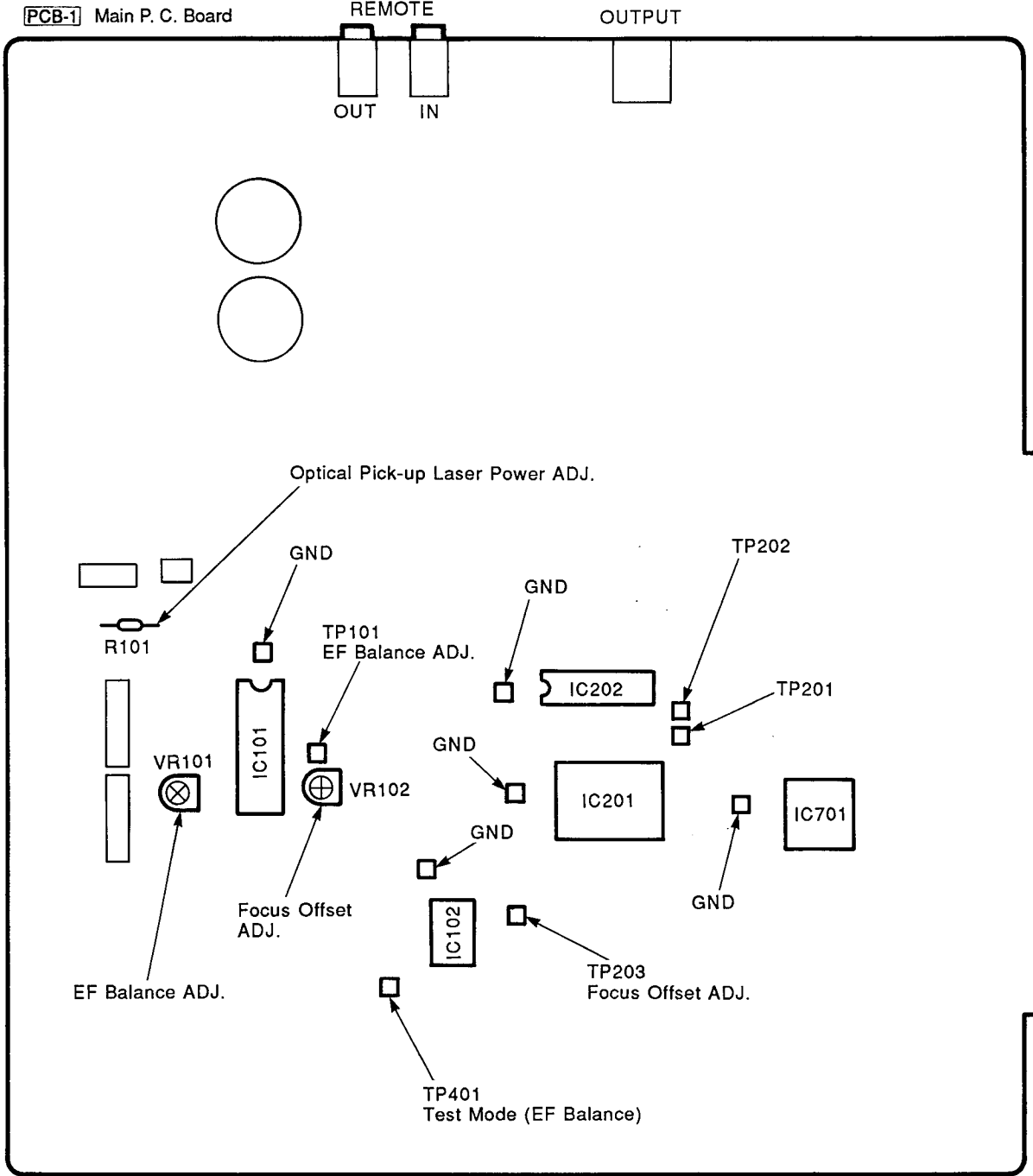

3. Optical Pick-up Laser Power Adjustment

The specified value for adjustment varies with the type of the pick-up in use. Obtain the voltage value according to the following procedure.

- (a) Read the current value on the label of the pick-up P.C.board.
- (b) Using the amperage of the current and the following equation, calculate the voltage value.

When the current is 44.1mA: $V=0.0441A \times 22=0.9702V$

- (1) Connect the DC voltmeter to both ends of R101.
- (2) Insert EIAJ CD-1 test disc and place the unit in the Play mode.
- (3) Adjust VR01 in the pick-up P.C.board to the voltage obtained in step (b) above.

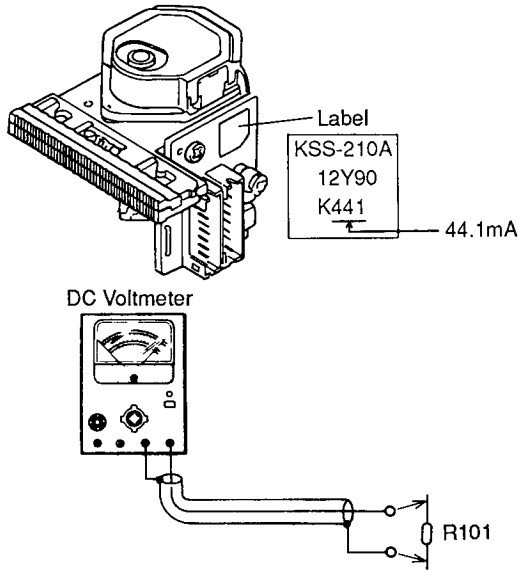

4. EF Balance Adjustment

- (1) Connect the oscilloscope (0.5V/div, 5 msec./div, DC mode) to TP101 and GND. Short-circuit TP401 and GND.
- (2) Insert EIAJ CD-1 test disc and place the unit in the Play mode.
- (3) Adjust VR101 so that the amplitude above and below the zero DC line becomes equal. (Amplitude A = Amplitude B)

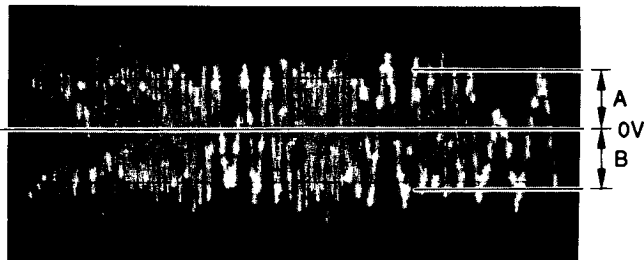
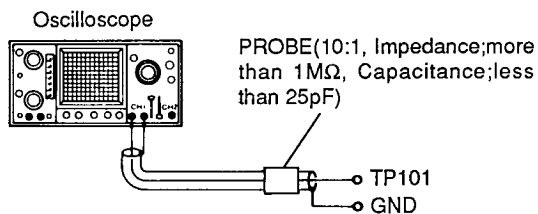

A=B

(approx. 1.5Vp-p)

5. Focus Offset Adjustment

- (1) Connect the Jitter meter to TP203 and GND.
- (2) Insert EIAJ CD-1 test disc and place the unit in the play mode.
- (3) Adjust VR102 until the jitter for optimum sensitivity.

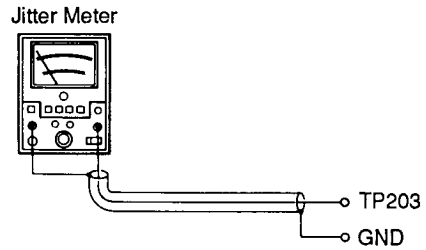

6. Jitter Inclination Confirmation

- (1) Connect the Jitter meter (sigma range) to TP203 and GND.
- (2) Insert EIAJ CD-1 test disc and place the unit in the Play mode.
- (3) Confirm the jitter meter reading is less than 30ns.

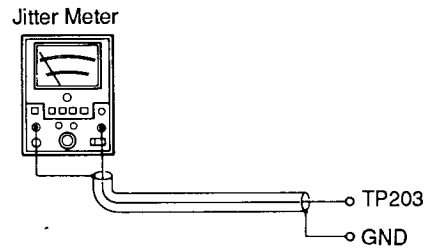

TROUBLE SHOOTING

When a trouble has occurred, first check the pick-up lens for dirt and each connector for tight and secure connection. If the problem persists after checking both of these items, use the following check procedures.

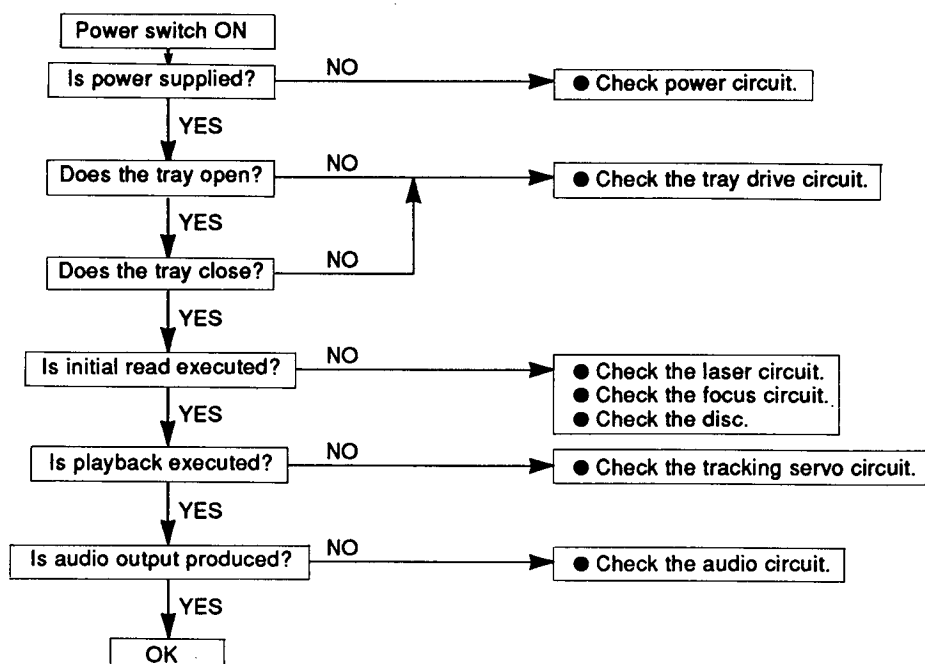

(1) When Multi Display fails to light properly

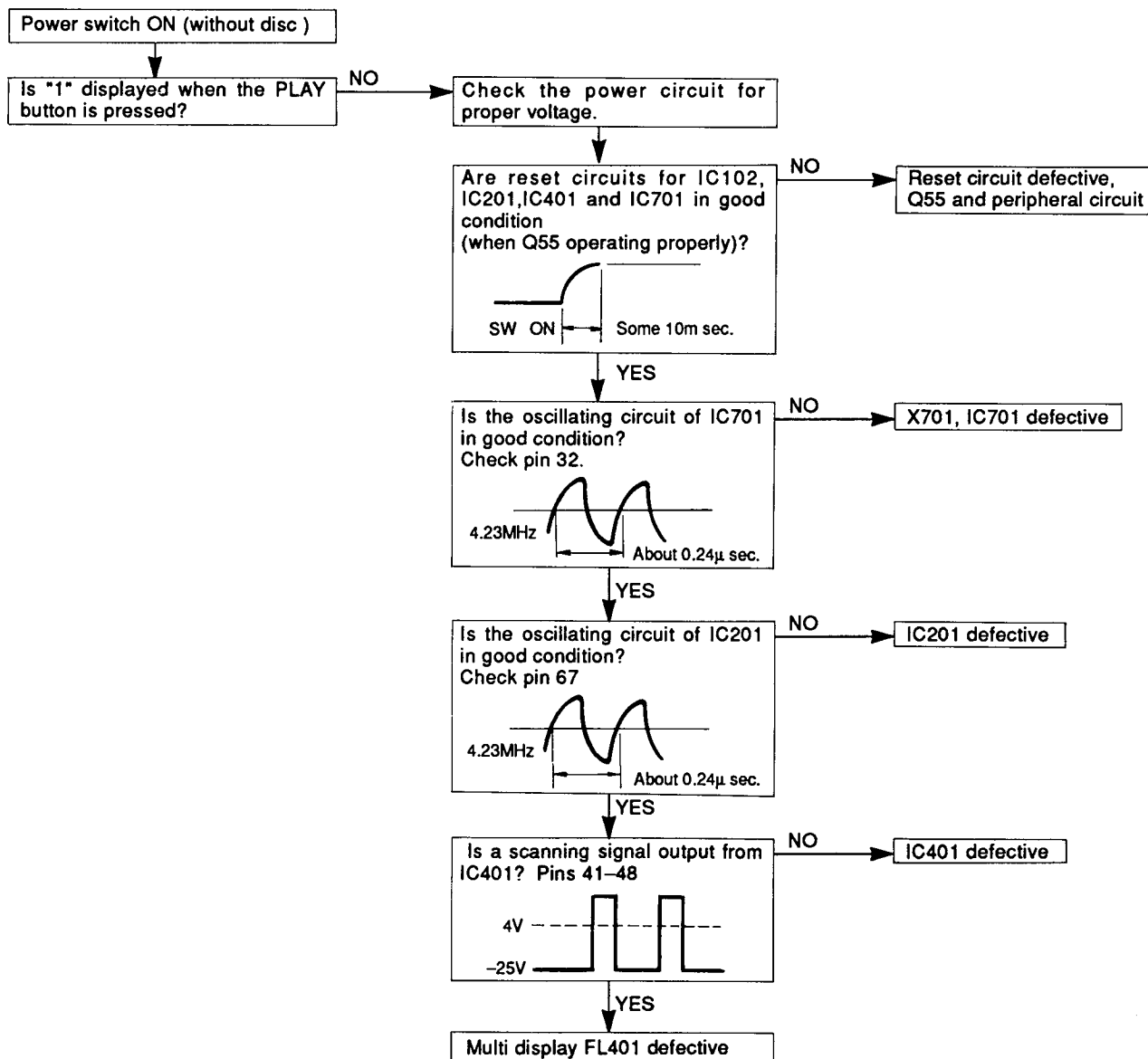

(2) When the tray fails to operate properly

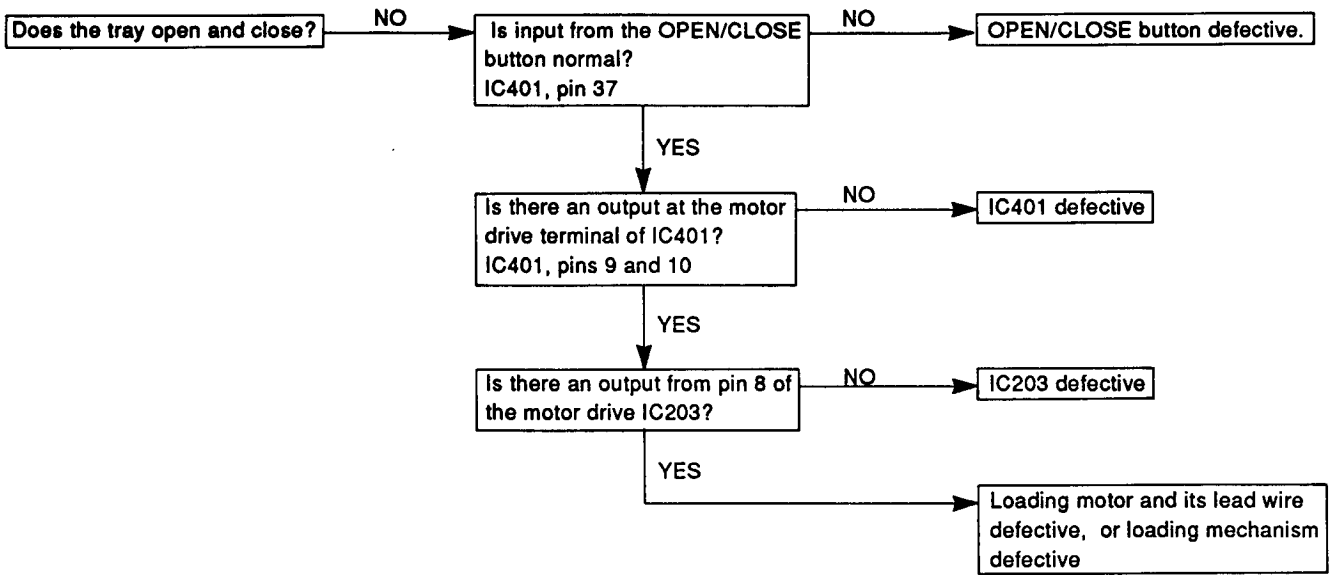

(3) When initial read cannot be executed

The following checks can be done without a disc loaded.

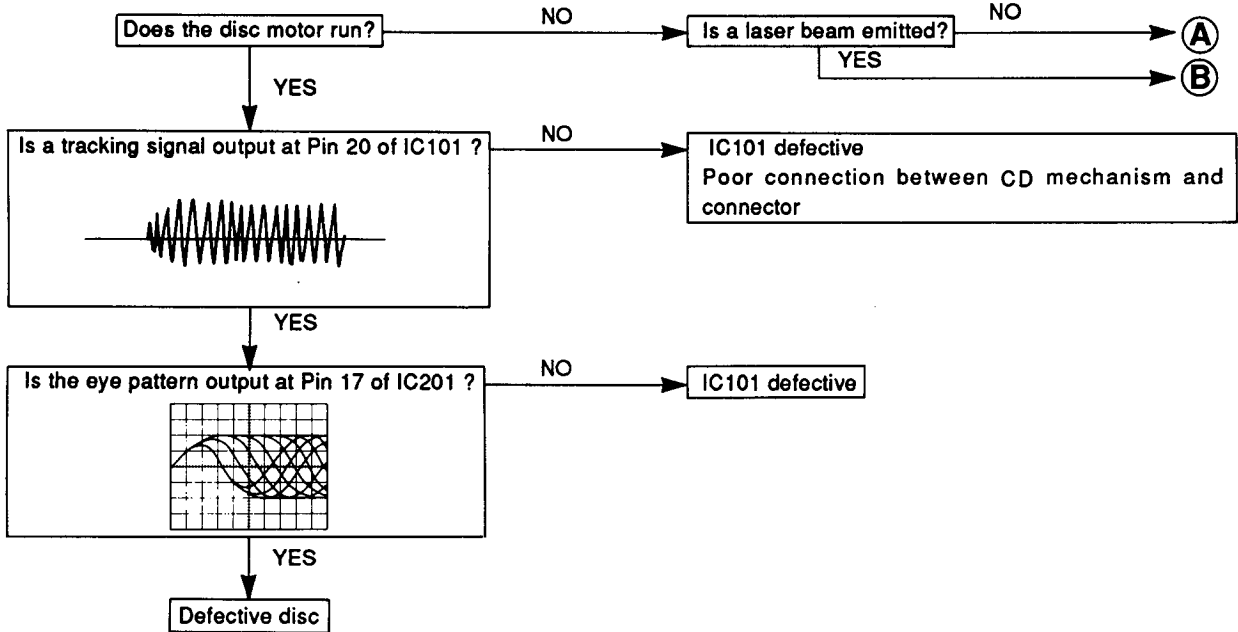

A When laser beam is not emitted

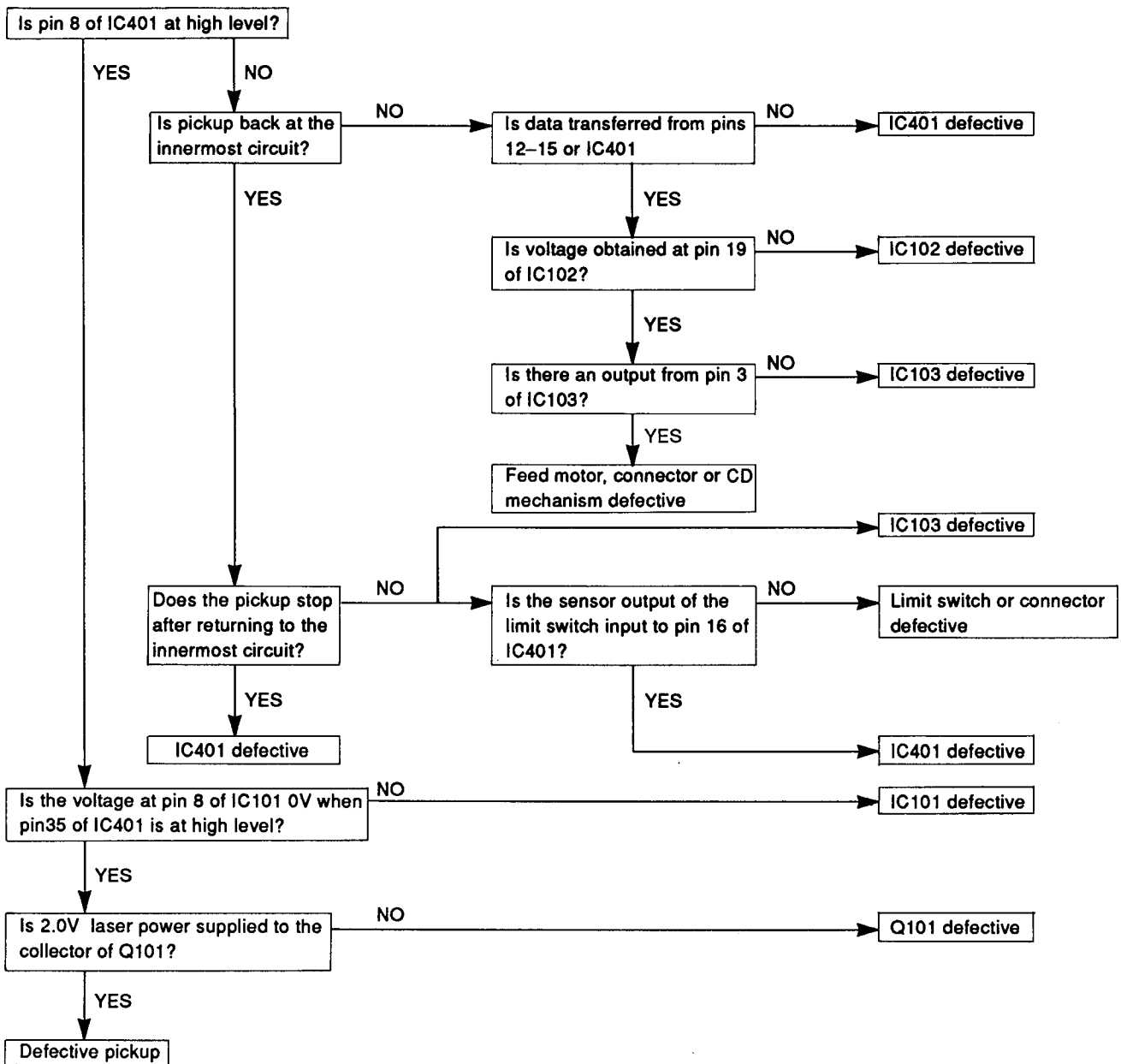

B When laser beam is emitted

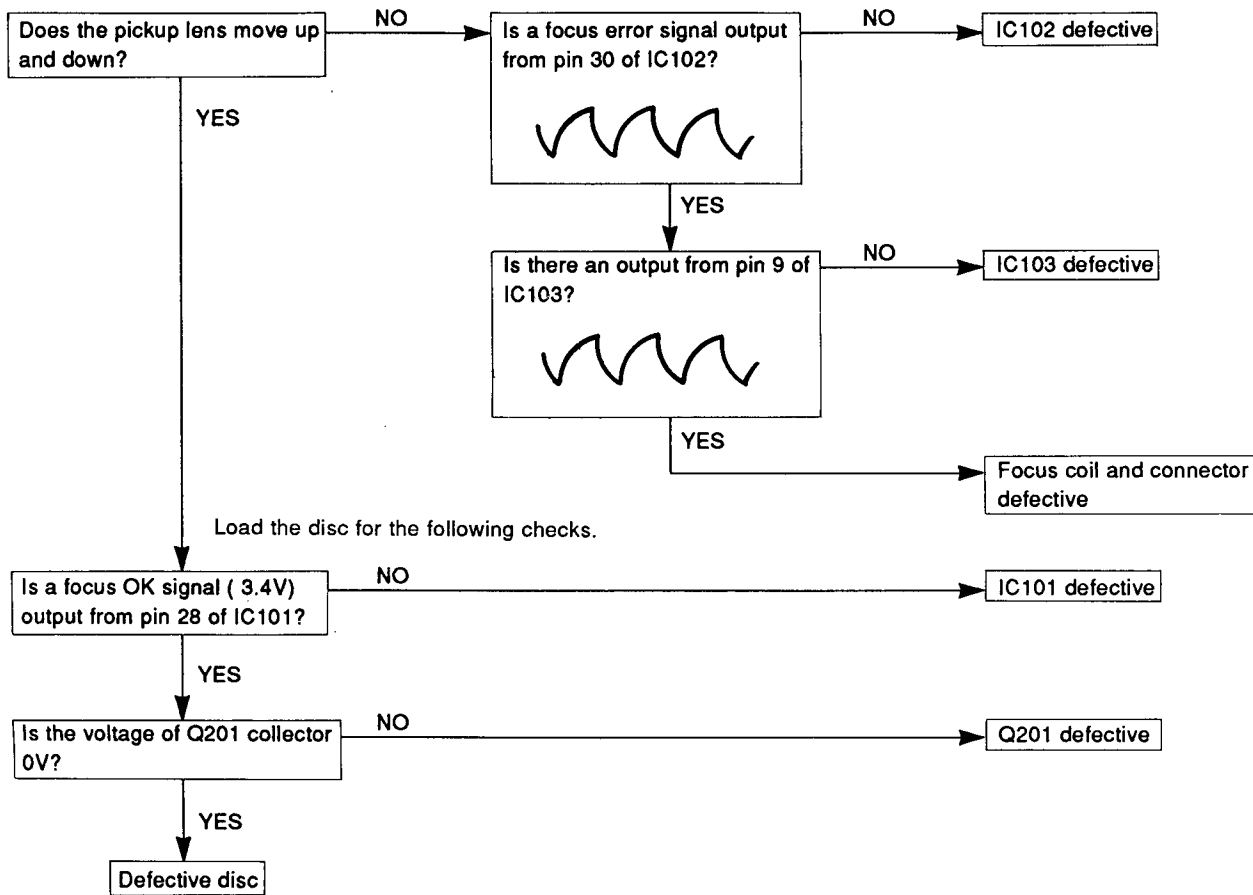

When there is no audio output

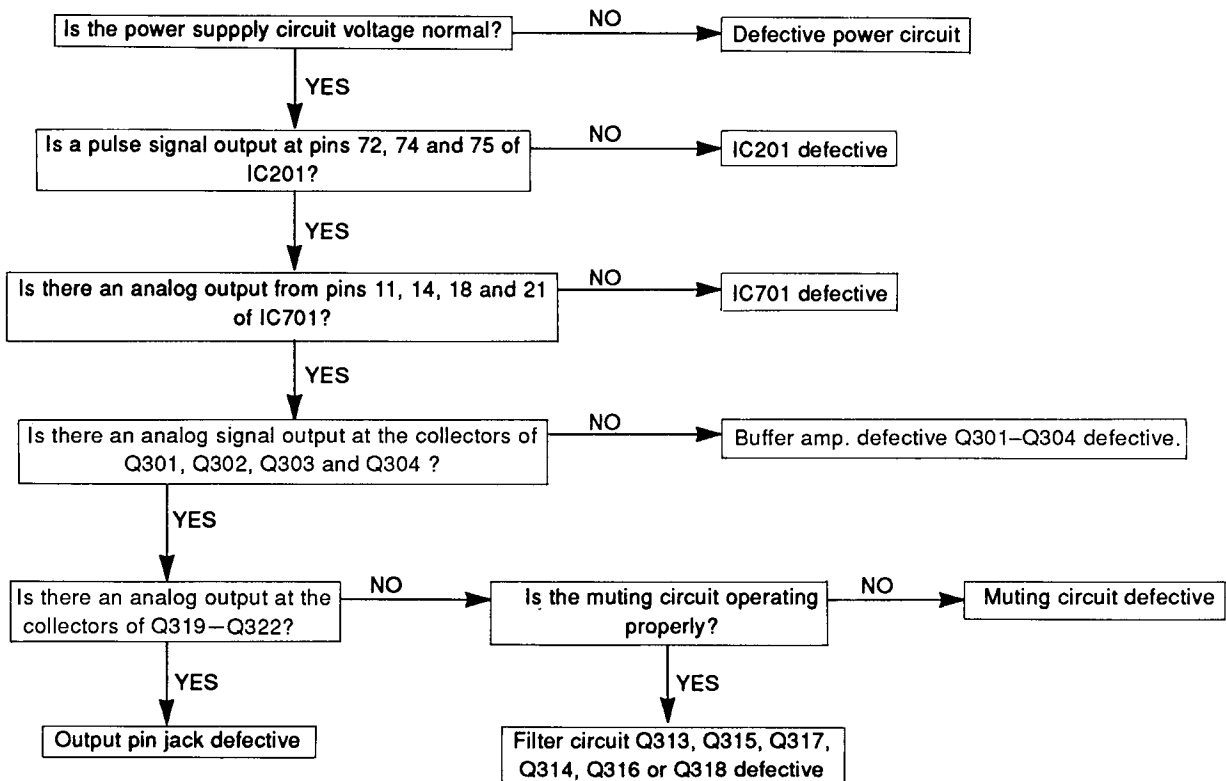

IC TERMINAL FUNCTIONS

| IC number | Terminal number | Port name | Terminal code | I/O | Outline of functions |
|-----------|-----------------|-----------|---------------|-----|-----------------------------------------|
| IC101 | 1 | RFI | | I | RF summing amp. input terminal. |
| | 2 | RFO | | O | RF summing amp. output terminal. |
| | 3 | RF- | | I | RF summing amp. return input terminal. |
| | 4 | P/N | | I | Laser diode P/N select terminal. |
| | 5 | LD | | O | APC LD amp. output terminal. |
| | 6 | PD | | I | APC PD amp. input terminal. |
| | 7 | PD1 | | I | RF I-V amp. (1) invert input terminal. |
| | 8 | PD2 | | I | RF I-V amp. (2) invert input terminal. |
| | 9 | VC | | — | GND terminal. |
| | 10 | F | | I | F I-V amp. invert input terminal. |
| | 11 | E | | I | E I-V amp. invert input terminal. |
| | 12 | EO | | O | E I-V amp. output terminal. |
| | 13 | EI | | I | E I-V amp. return input terminal. |
| | 14 | VR | | O | DC voltage output terminal. |
| | 15 | CC2 | | I | DEFECT signal input terminal. |
| | 16 | CC1 | | O | DEFECT signal output terminal. |
| | 17 | VEE | | — | Negative power terminal. |
| | 18 | FE BIAS | | I | Focus error amp. bias terminal. |
| | 19 | FE | | O | Focus error amp. output terminal. |
| | 20 | TE | | O | Tracking error amp. output terminal. |
| | 21 | DEFECT | | O | DEFECT comparator output terminal. |
| | 22 | MIRR | | O | MIRR comparator output terminal. |
| | 23 | CP | | I | MIRR hold capacitor connect terminal. |
| | 24 | CB | | I | DEFECT hold capacitor connect terminal. |
| | 25 | DGND | | — | GND terminal. |
| | 26 | ASY | | I | Auto asymmetry control input terminal. |
| | 27 | EFM | | O | EFM comparator output terminal. |
| | 28 | FOK | | O | Focus OK comparator output terminal. |
| | 29 | LD ON | | I | Laser diode on/off select terminal. |
| | 30 | Vcc | | — | Positive power terminal. |

| IC number | Terminal number | Port name | Terminal code | I/O | Outline of functions |
|-----------|-----------------|-----------|----------------|-----|-------------------------------------------------------------------------------------------------------------------------------------------|
| IC102 | 1 | TE IN | Pre amp. input | I | Tracking error signal input terminal. |
| | 2 | TC IN | Pre amp. input | I | Track cross signal input terminal. |
| | 3 | SHOCK IN | Pre amp. input | I | Shock detector signal input terminal. |
| | 4 | HF OK | Pre amp. input | I | HF OK signal input terminal. |
| | 5 | MR | Pre amp. input | I | Mirror detected signal input terminal. |
| | 6 | Jump Flag | Mi-com I/O | O | Outputs "H" under jump function. |
| | 7 | HFD | Mi-com I/O | O | "1" indicates that MR input is "1" and track servo loop is off (TS OFF, JF, JR). |
| | 8 | T•HLD | Track servo | I | Direct control terminal for TS1 switch. "1" indicates that TS1 switch is "b". "0" indicates that priority is given to controller command. |
| | 9 | DATA OUT | Mi-com I/O | O | Inner condition output changed by command modes. |
| | 10 | JP1 | Mi-com I/O | I | 1 track jump control signal. Usually "H". |
| | 11 | MSD | Mi-com I/O | I | Serial data input terminal (LSB first, 8-bit data). |
| | 12 | MLA | Mi-com I/O | I | Latch signal of serial data from mi-com to servo IC. |
| | 13 | MCK | Mi-com I/O | I | Clock signal of serial data from mi-com to servo IC. Receives data on leading edge. |
| | 14 | ACLR | Mi-com I/O | I | All clear input. (Clear inner registers and flip-flops by "L" signal.) |
| | 15 | Bias | Power supply | O | Vcc/2 bias power supply output when single-pole power supply is used. |
| | 16 | COM | Power supply | I | Common terminal. Connect to GND when double-pole power supply is used and to BIAS when single-pole power supply is used. |
| | 17 | GND | Power supply | I | GND terminal. |
| | 18 | VEE | Power supply | I | Negative power terminal. Connect to GND when single-pole power supply is used. |
| | 19 | SS OUT | Slide servo | O | Operation amplifier SS output. |
| | 20 | SS - | Slide servo | I | Operation amplifier SS reverse input. |
| | 21 | SS + | Slide servo | I | Operation amplifier SS non-reverse input. |
| | 22 | TS OUT | Track servo | O | Operation amplifier TA output. |

| IC number | Terminal number | Port name | Terminal code | I/O | Outline of functions |
|-----------|-----------------|-----------|---------------|-----|-----------------------------------------------------------------------------------------|
| IC102 | 23 | TS - | Track servo | I | Operation amplifier TA reverse input. |
| | 24 | TG2 | Track servo | - | Track gain select switch TG2 output. Set to open or common level. |
| | 25 | TS + | Track servo | I | Operation amplifier TA non-reverse input. |
| | 26 | TG1 | Track servo | - | Track gain select switch TG1 output. Set to open or common level. |
| | 27 | TE OUT | Track servo | O | Operation amplifier TE output. |
| | 28 | TE - | Track servo | I | Operation amplifier TE reverse input. |
| | 29 | FSR IN | Focus servo | I | Focus search voltage level detector input. |
| | 30 | FS OUT | Focus servo | O | Operation amplifier FA output. |
| | 31 | FS - | Focus servo | I | Operation amplifier FA reverse input. |
| | 32 | FS + | Focus servo | I | Operation amplifier FA non-reverse input. |
| | 33 | FG | Focus servo | - | Focus gain select switch FG output. Set to open or common level. |
| | 34 | C-FSR | Focus servo | - | Connect capacitor which determines time constant of focus search waveform. |
| | 35 | I-Ref | Power supply | I | Terminal for connecting resistor for setting current value of reference current source. |
| | 36 | Vcc | Power supply | I | Positive power terminal. |
| IC103 | 1 | +VIN 1 | | I | Positive input terminal 1 for amp. 1. |
| | 2 | -VIN 1 | | I | Negative input terminal 1 for amp. 1. |
| | 3 | OUT 1 | | O | Output terminal 1. |
| | 4 | OUT 2 | | O | Output terminal 2. |
| | 5 | -VIN 2 | | I | Negative input terminal 2 for amp. 2. |
| | 6 | +VIN 2 | | I | Positive input terminal 2 for amp. 2. |
| | 7 | +VIN 3 | | I | Positive input terminal 3 for amp. 3. |
| | 8 | -VIN 3 | | I | Negative input terminal 3 for amp. 3. |
| | 9 | OUT 3 | | O | Output terminal 3. |
| | 10 | NC | | - | |

| IC number | Terminal number | Port name | Terminal code | I/O | Outline of functions |
|-----------|-----------------|-----------|---------------|-----|------------------------------------------------------------------|
| IC103 | 11 | NC | | — | |
| | 12 | Vcc | | — | Positive power supply. |
| IC201 | 1 | EMP | | O | Emphasis code output. Emphasis = "1" |
| | 2 | PWM1 | | O | Disc motor drive PWM output 1. - |
| | 3 | PWM2 | | O | Disc motor drive PWM output 2. + |
| | 4 | DOTX | | O | Digital output. |
| | 5 | ACRCY | | I | Channel status clock input. |
| | 6 | TEST1 | | I | Test mode select input. |
| | 7 | DOBSEL | | I | Output data bit select. |
| | 8 | DASEL1 | | I | D/A converter interface select input 1. |
| | 9 | DASEL2 | | I | D/A converter interface select input 2. |
| | 10 | DASEL3 | | I | D/A converter interface select input 3. |
| | 11 | DASEL4 | | I | D/A converter interface select input 4. |
| | 12 | MSD | | I | Microcomputer interface serial data input. |
| | 13 | MCK | | I | Microcomputer interface shift clock input. |
| | 14 | MLA | | I | Microcomputer interface data latch clock input |
| | 15 | ACLR | | I | Microcomputer interface register clear input. |
| | 16 | HFD | | I | Play signal absence signal input. |
| | 17 | HF | | I | Play signal input. |
| | 18 | IREF | | I | Detection/PLL circuit reference current input. |
| | 19 | TLC | | O | Slice level control output. |
| | 20 | LPF | | I/O | PLL loop filter connection terminal. |
| | 21 | LOCK/DRD | | O | Synchronous/low disc rotate status output. |
| | 22 | SYCLK | | O | Frame synchronous status output. |
| | 23 | VDD2 | | I | 5V power supply used for Detection/PLL circuit analog area only. |
| | 24 | DRD | | O | Low disc rotate status output. |
| | 25 | EFFK | | O | EFM frame clock output. |
| | 26 | SCINT | | O | Subcode Q interrupted signal output. |
| | 27 | SQRO | | O | Subcode Q register output. |
| | 28 | SQRCK | | I | Subcode Q register data shift clock input. |
| | 29 | SCOR | | O | Subcode synchronous signal output. |

| IC number | Terminal number | Port name | Terminal code | I/O | Outline of functions |
|-----------|-----------------|-----------|---------------|-----------------------------------|------------------------------------------------------|
| IC201 | 30 | CRCF | | O | Subcode Q CRC check result output. |
| | 31 | SCCK | | I | Shift clock input for serial subcode data output. |
| | 32 | Vss2 | | I | GND terminal. |
| | 33 | SCOE2 | | I | Subcode parallel output channel P to S enable input. |
| | 34 | SCOE1 | | I | Subcode parallel output channel T to W enable input. |
| | 35 | SBCW | | O | Subcode channel W output. |
| | 36 | SBCV | | O | Subcode channel V output. |
| | 37 | SBCU | | O | Subcode channel U output. |
| | 38 | SBCT | | O | Subcode channel T output. |
| | 39 | SBCS | | O | Subcode channel S output. |
| | 40 | SBCR | | O | Subcode channel R output. |
| | 41 | SBCQ | | O | Subcode channel Q output. |
| | 42 | SBCP | | O | Subcode channel P output. |
| | 43 | RAS | | O | Row address strobe signal output. |
| | 44 | NC | | — | |
| | 45 | RDB2 | | I/O | External memory data I/O 2. |
| | 46 | NC | | — | |
| | 47 | RDB1 | | I/O | External memory data I/O 1. |
| | 48 | RDB4 | | I/O | External memory data I/O 4. |
| | 49 | CAS | | O | Column address strobe signal output. |
| | 50 | RDB3 | | I/O | External memory data I/O 3. |
| | 51 | WE | | O | Write enable signal output. |
| | 52 | NC | | — | |
| | 53 | RAD1 | | O | External memory address output 1. |
| | 54 | RAD2 | | O | External memory address output 2. |
| | 55 | RAD3 | | O | External memory address output 3. |
| | 56 | RAD7 | | O | External memory address output 7. |
| | 57 | RAD4 | | O | External memory address output 4. |
| | 58 | RAD5 | | O | External memory address output 5. |
| 59 | RAD6 | | O | External memory address output 6. | |

| IC number | Terminal number | Port name | Terminal code | I/O | Outline of functions |
|-----------|-----------------|-----------|---------------|---------------------------------|----------------------------------------|
| IC201 | 60 | RAD0 | | O | External memory address output 0. |
| | 61 | EST2 | | O | Error status 2. |
| | 62 | EST1 | | O | Error status 1. |
| | 63 | VDD1 | | I | 5V power supply. |
| | 64 | DOFK | | O | OSC frame clock output. |
| | 65 | FSCK | | O | Clock output. 44.1kHz |
| | 66 | C846 | | O | Clock output. 8.4672MHz |
| | 67 | C423 | | O | Clock output. 4.2336MHz |
| | 68 | C16MI | | I | 1/2 divider input. |
| | 69 | C8MO | | O | 1/2 divider output. |
| | 70 | XI | | I | Crystal oscillator input. |
| | 71 | XO | | O | Crystal oscillator output. |
| | 72 | DO1 | | O | D/A converter serial data output. |
| | 73 | VSS1 | | I | GND terminal. |
| | 74 | DSCK | | O | D/A converter data shift clock output. |
| | 75 | LRCK | | O | D/A converter left/right clock output. |
| | 76 | DO2 | | O | Dual D/A converter serial data output. |
| | 77 | WDCK | | O | D/A converter word clock. |
| | 78 | DLRCK | | O | D/A converter left/right clock output. |
| | 79 | APTL | | O | D/A converter deglitch clock L. |
| 80 | APTR | | O | D/A converter deglitch clock R. | |
| IC202 | 1 | OE | | I | Output enable input. |
| | 2 | DQ1 | | I/O | Data I/O. |
| | 3 | DQ2 | | I/O | Data I/O. |
| | 4 | W | | I | Write control input. |
| | 5 | RAS | | I | Row address strobe input. |
| | 6 | A6 | | I | Address input. |
| | 7 | A5 | | I | Address input. |
| | 8 | A4 | | I | Address input. |
| | 9 | VCC | | — | Power supply (5V). |
| | 10 | A7 | | I | Address input (row address only). |

| IC number | Terminal number | Port name | Terminal code | I/O | Outline of functions |
|-----------|-----------------|-----------|---------------|-----|-------------------------------------------|
| IC202 | 11 | A3 | | I | Address input. |
| | 12 | A2 | | I | Address input. |
| | 13 | A1 | | I | Address input. |
| | 14 | A0 | | I | Address input (row address only) |
| | 15 | DQ3 | | I/O | Data I/O. |
| | 16 | CAS | | I | Column address strobe input. |
| | 17 | DQ4 | | I/O | Data I/O. |
| | 18 | Vss | | — | Power supply (0V). |
| IC203 | 1 | VSENCE1 | | | |
| | 2 | OUT1 | | O | Output terminal 1. |
| | 3 | -VIN1 | | I | Negative power supply. |
| | 4 | +VIN1 | | I | Positive input 2. |
| | 5 | VEE | | | Negative input 2. |
| | 6 | +VIN2 | | I | Positive power supply. |
| | 7 | -VIN2 | | I | Negative input 2. |
| | 8 | OUT2 | | O | Output terminal 2. |
| | 9 | VSENCE2 | | | |
| | 10 | Vcc | | | Positive power supply. |
| IC401 | 1 | Vcc | | | Positive power supply. |
| | 2 | P65 | | I/O | |
| | 3 | P64 | | I/O | |
| | 4 | P63 | | I/O | |
| | 5 | P62 | | I/O | |
| | 6 | P61 | | I/O | |
| | 7 | P60 | | I/O | |
| | 8 | P27 | I/O port | I/O | Disc tray open direction driving output. |
| | 9 | P26 | I/O port | I/O | Disc tray close direction driving output. |
| | 10 | P25 | I/O port | I/O | |
| | 11 | P24 | I/O port | I/O | Serial data output. |
| | 12 | P23 | I/O port | I/O | Serial data output. |
| | 13 | P22 | I/O port | I/O | Data latch clock output. |

| IC number | Terminal number | Port name | Terminal code | I/O | Outline of functions |
|-----------|-----------------|-----------------|---------------|-----|-----------------------------|
| IC401 | 14 | P2 ₁ | I/O port | I/O | |
| | 15 | P2 ₀ | I/O port | I/O | |
| | 16 | P3 ₇ | OUT PORT | O | Display output i. |
| | 17 | P3 ₆ | OUT PORT | O | Display output g. |
| | 18 | P3 ₅ | OUT PORT | O | Display output f. |
| | 19 | P3 ₄ | OUT PORT | O | Display output e. |
| | 20 | P3 ₃ | OUT PORT | O | Display output d. |
| | 21 | P3 ₂ | OUT PORT | O | Display output c. |
| | 22 | P3 ₁ | OUT PORT | O | Display output b. |
| | 23 | P3 ₀ | OUT PORT | O | Display output a. |
| | 24 | P5 ₃ | | | |
| | 25 | P5 ₂ | | | |
| | 26 | CNVss | | | Usually connected to Vss. |
| | 27 | RESET | | I | Reset input. |
| | 28 | XIN | CLOCK IN | I | Clock input. |
| | 29 | XOUT | CLOCK OUT | O | Clock output. |
| | 30 | XCIN | CLOCK IN | I | Serial data input. |
| | 31 | XCOU | CLOCK OUT | O | Clock output. |
| | 32 | Vss | | | Power Supply. |
| | 33 | ∅ | | O | Timing output. |
| | 34 | P5 ₇ | | | |
| | 35 | P5 ₆ | | | |
| | 36 | P5 ₅ | | | |
| | 37 | P5 ₄ | | | |
| | 38 | VP | | I | Pull down voltage input. |
| | 39 | P5 ₁ | | | |
| | 40 | P5 ₀ | | | |
| | 41 | P1 ₇ | OUT PORT | O | Laser diode control output. |
| | 42 | P1 ₆ | OUT PORT | O | Display output 7. |
| | 43 | P1 ₅ | OUT PORT | O | Display output 6. |
| | 44 | P1 ₄ | OUT PORT | O | Display output 5. |

| IC number | Terminal number | Port name | Terminal code | I/O | Outline of functions |
|-----------|-----------------|-----------|---------------|-----|----------------------------------------------------------------|
| IC401 | 45 | P13 | OUT PORT | O | Display output 4. |
| | 46 | P12 | OUT PORT | O | Display output 3. |
| | 47 | P11 | OUT PORT | O | Display output 2. |
| | 48 | P10 | OUT PORT | O | Display output 1. |
| | 49 | P07 | I/O port | I/O | Serial data input. |
| | 50 | P06 | I/O port | I/O | Frame synchronous state output. |
| | 51 | P05 | I/O port | I/O | Low disc rotate state output. |
| | 52 | P04 | I/O port | I/O | Sub-code synchronous signal output. |
| | 53 | P03 | I/O port | I/O | Sub-code Q check. |
| | 54 | P02 | I/O port | I/O | Sub-code channel Q output. |
| | 55 | P01 | I/O port | I/O | Interrupt input. |
| | 56 | P00 | I/O port | I/O | |
| | 57 | P47 | | | |
| | 58 | P46 | | | |
| | 59 | P45 | | | |
| | 60 | P44 | | | |
| | 61 | P43 | | | |
| | 62 | P42 | | | |
| | 63 | P41 | | | |
| | 64 | P40 | | | |
| IC701 | 1 | MLD | | I | Mi-com command load input terminal. Low level=load |
| | 2 | RSTB | | | Reset terminal. Low level=active |
| | 3 | IE | | I | Low level=LSI format. High level=I2S format. |
| | 4 | TP1 | | O | Digital filter test output terminal 1. |
| | 5 | TP2 | | O | Digital filter test output terminal 2. |
| | 6 | TEST 1 | | I | Digital filter test signal input terminal 1. Nominal=Low level |
| | 7 | TEST 2 | | I | Digital filter test signal input terminal 2. Nominal=Low level |
| | 8 | NC | | | |
| | 9 | NC | | | |
| | 10 | AVDD 4 | | | Analog power supply terminal 4. (+5V) |
| | 11 | OUTL(-) | | O | L ch. negative PWM output terminal. |

| IC number | Terminal number | Port name | Terminal code | I/O | Outline of functions |
|-----------|-----------------|-----------|---------------|-----|-----------------------------------------------------------------|
| IC701 | 12 | AVSS 4 | | | Analog ground terminal 4. |
| | 13 | AVSS 3 | | | Analog ground terminal 3. |
| | 14 | OUTL(+) | | O | L ch. positive PWM output terminal. |
| | 15 | AVDD 3 | | | Analog power supply terminal 3. (+5V) |
| | 16 | NC | | | |
| | 17 | AVDD 2 | | | Analog power supply terminal 2. (+5V) |
| | 18 | OUTR(+) | | O | R ch. positive PWM output terminal. |
| | 19 | AVSS 2 | | | Analog ground terminal 2. |
| | 20 | AVSS 1 | | | Analog ground terminal 1. |
| | 21 | OUTR(-) | | O | R ch. negative PWM output terminal. |
| | 22 | AVDD 1 | | | Analog power supply terminal 1. (+5V) |
| | 23 | DVDD 1 | | | Digital power supply terminal 1 for oscillator. (+5V) |
| | 24 | DVSS 1 | | | Digital ground terminal 1 for oscillator. |
| | 25 | X2 | | | Crystal oscillator. |
| | 26 | X1 | | | Crystal oscillator (external clock input terminal). |
| | 27 | NC | | | |
| | 28 | DVDD 2 | | | Digital power supply terminal 2. (+5V) |
| | 29 | DVSS 2 | | | Digital ground terminal 2. |
| | 30 | NSUB | | | Connect to the D-VDD terminal. |
| | 31 | ZFLGB | | O | Zero signal detect output terminal. |
| | 32 | 192FS | | O | Clock output. 8.4672MHz |
| | 33 | LRPOL | | | Polarity (L ch. and R ch.) select terminal. L level=R H level=L |
| | 34 | LRCLK | | I | LRCLK input terminal. |
| | 35 | BCLK | | I | Serial input bit clock. |
| | 36 | SRDATA | | I | Serial data input terminal. |
| | 37 | DVSS 3 | | | Digital ground terminal 3. |
| | 38 | DVDD | | | Digital power supply terminal. (+5V) |
| | 39 | 384FS | | O | Clock output. 16.9344MHz |
| | 40 | PD | | | Power down terminal. High level=active |
| | 41 | MDATA | | I | Mi-com command data input terminal. |
| | 42 | MCLK | | I | Clock input terminal for mi-com command. |

CIRCUIT DESCRIPTION

1. APC CIRCUIT

A semiconductor laser is used as the light source for the optical pickup. As the output from the semiconductor laser changes radically with changes in temperature, a circuit must be provided to stabilize this output. For this purpose, a monitor diode which detects the optical output of the laser diode is used in the semiconductor laser.

As the laser diode emits light from its bonded surface, light is emitted both in front and behind. The light emitted behind is monitored with the monitor diode installed on its rear surface, and the optical output is thus controlled. The light emitted in front becomes the light source for the pickup.

Fig. 1 shows the APC circuit.

When the temperature rises and the optical output decreases, the monitor diode current (I_S) decreases, the electric potential of IC101 pin 5 rises, the base current of the driving transistor increases, and the laser diode current increases. This causes the reduced optical output to return to its former level.

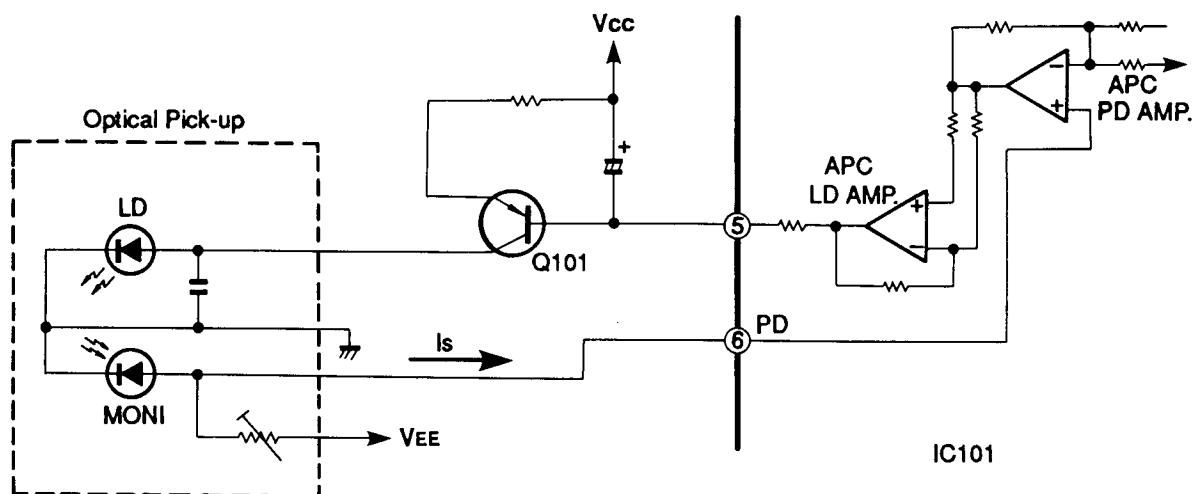

Fig. 1

2. FOCUS SERVO

2-1. Optical pickup

This set employs a three-beam optical pickup comprised of six division photodiodes, A through F as shown in Fig. 2. The four photodiodes (A through D) at the center provide focus error detection by using their property to allow the beam to focus into a round image only at a certain point.

The sums of outputs from diagonal two elements of four division photodiodes (A+C and B+D) are compared by the differential amplifier in IC101 to detect the shape of the beam image.

The remaining two diodes (E and F) provide tracking error detection by means of sub-beam spots.

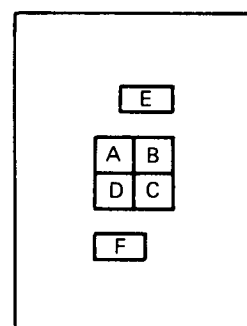

Three spotted (six-division) photo diodes

Fig. 2

2-2. Focus error detecting operation

The reflected laser beam from a disc is polarized 90° with the beam-splitter and sent to the cylindrical lens. The beam passed through this cylindrical lens is then sent to the four division photodiodes and focuses into an image whose shape varies with the distance between the disc and the objective lens. Such change in the beam shape causes the current flowing from the photodiodes to vary.

Shown in Fig. 3 is the principle of the focus error detection.

The currents from the photodiodes (A+C and B+D) are applied to pins 7 and 8 of IC101 and converted to voltage by RF I-V amplifiers (1) and (2) included in IC101.

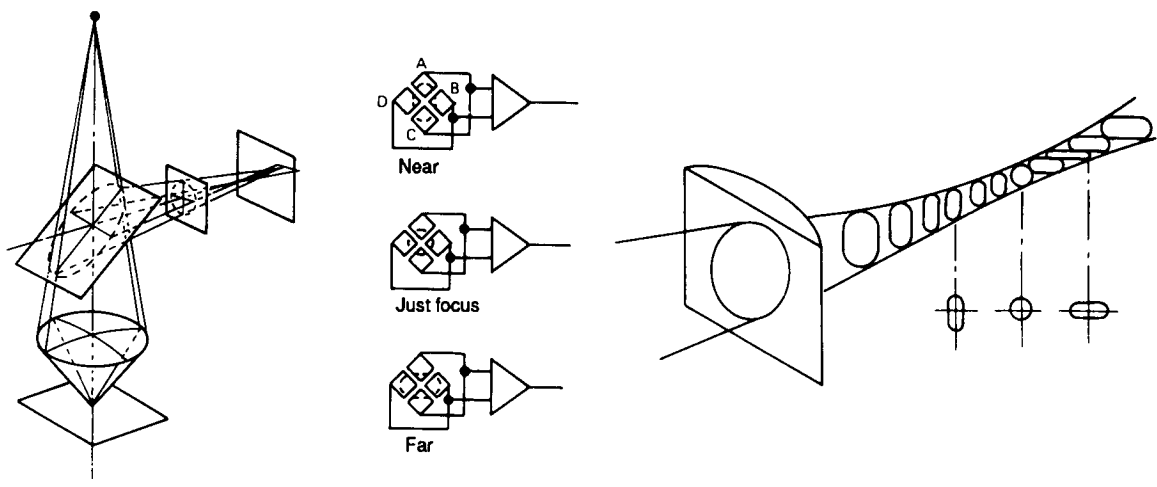

Fig.3

2-3. Focus servo control operation

The focus error signal, after being converted to voltage by the RF I-V amplifier, is transmitted to the operation amplifier in the IC and output from pin 19.

When the disc to objective lens distance is in just focus, the beam forms a true round. In this state, the beams applied to four elements of four division photodiodes become equal and thus the output provided then is 0(zero). When the disc to objective lens distance is too close (near focus), the beam is reflected divergently to form an oval in crosswise direction. In this state, the outputs provided from photodiodes A and C are higher than those from B and D, resulting in negative (-) output voltage. On the other hand, when the distance is too far (far focus), the beam is reflected convergently to form an oval in longitudinal direction. Then the outputs from photodiodes B and D are higher, resulting in positive (+) output.

The output voltage (focus error signal) from pin 19 of IC101 passes through IC102, in from pin 32 and out from pin 30, and IC103, in from pin 7 out from pin 9 as shown in Fig. 4. It is amplified in each IC and fed to the focus coil which then drives the objective lens of the pickup.

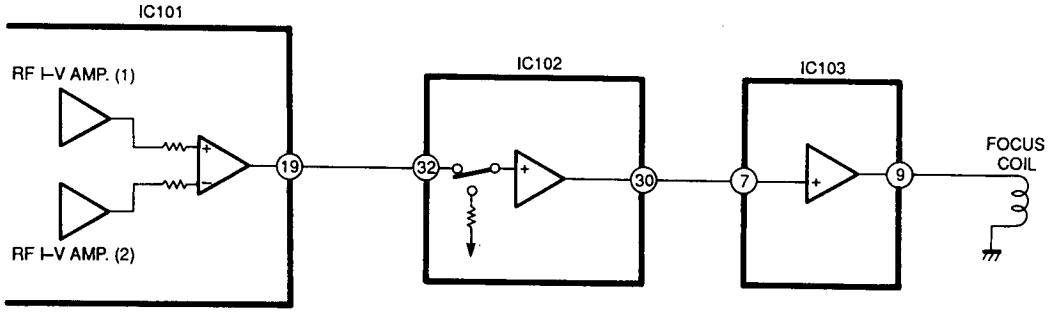

Fig. 4

2-4. Tracking error detection system

Fig. 5 shows the principle of the tracking error detection system which employs the three beam system. The laser beam is divided into the main beam and two sub-beams by diffraction grating and they are arranged on one line. The center line connecting these three beams has a slight offset angle against the main beam. The main beam is received by photodiodes A, B, C and D and two sub-beams by E and F respectively.

Fig. 5-A shows the on-track state. As both auxiliary beams 1 and 2 are slightly on the track in this state, the outputs of photodiodes E and F are equal and the tracking signal is 0(zero). When the track is shifted to the left (Fig. 5-B), the auxiliary beam 1 is off the pit. This allows more light to be received by the photodiode E, resulting in positive (+) tracking signal output. On the other hand, when the track is shifted to the right (Fig. 5-C), the amount of light received by the photodiode F increases, resulting in negative (-) tracking signal output. And these extreme signals are detected as tracking error signals.

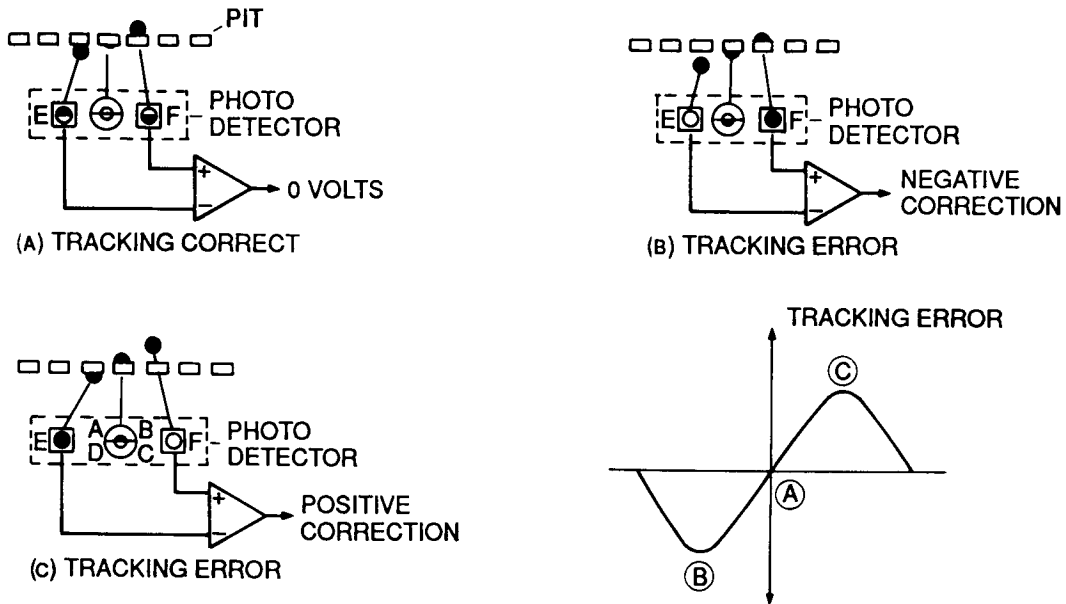

Fig. 5

2-5. Tracking servo control operation

When a tracking error signal is detected by photodiodes E and F, it is fed to pins 11 and 10 of IC101 respectively as shown in Fig. 6. In IC101, the signal is converted into voltage by the E I-V amplifier and F I-V amplifier, transmitted to the tracking error amplifier and output through pin 20. While it passes through IC102, in from pin 1 and out from pin 22, and IC103, in from pin 6 and out from 4, it is amplified in each IC and sent to the tracking coil to adjust pickup so that the amount of track shift is reduced as closely to none as possible.

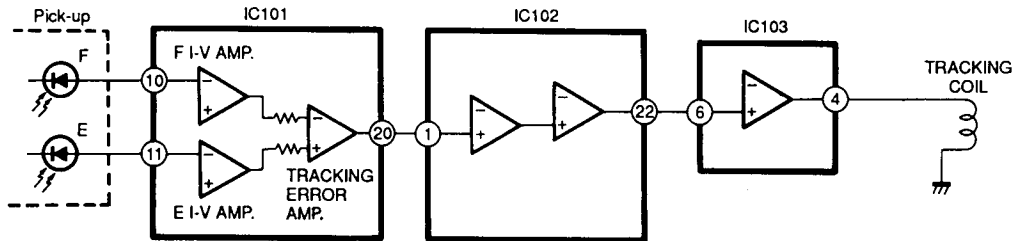

Fig. 6

3. Regenerative Circuit

3-1. RF circuit

The currents from photodiodes (a, b, c and d) are fed to IC101 through pins 7 and 8 and converted to voltage by RF I-V amplifiers (1) and (2) respectively there, added by the RF summing amplifier and output from pin 2 as a signal. As it is sent to pin 7 of IC201, it can be checked at the test point (TP201) provided on its way by means of the eye pattern check.

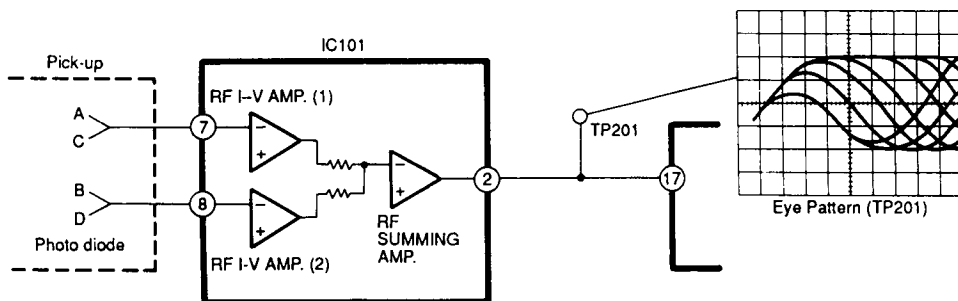

Fig. 7

3-2. EFM demodulation, error correction, serial/parallel conversion

EFM demodulation, error correction and serial/parallel conversion are performed by the internal circuitry of IC201. The eye-pattern signals from pin 2 of IC101 are sent to pin 17 of IC201, then demodulated from 14 bits to 8 bits by EFM readjustment. At the same time any error, if found, is corrected (CIRC) and the signals are sent to the D/A converter interface. After that, they are output as 18-bit digital signals from pins 72, 74 and 75 of IC201 and fed to the D/A converter of IC701.

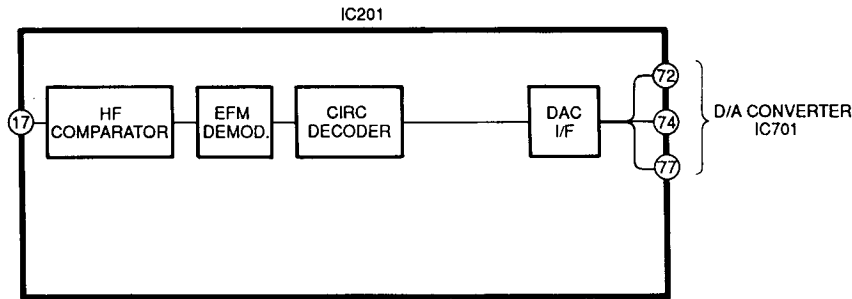

Fig. 8

4. 1-bit D/A Converter

Conventionally, high-precision D/A conversion was mainly carried out using resistor ladder systems. There was, however, one main drawback with these systems, which was that zero cross distortion was likely to be generated. To achieve production of a high-precision D/A converter with a minimum amount of zero cross distortion, it would be necessary to carry out complicated and bothersome processes such as laser trimming processing. In addition, use of such D/A converter would require a sampling-and-hold circuits (or de-glitcher circuit) and an intricate analog filter with special characteristics when mounting it.

To solve these difficulties, we used a 1-bit D/A converter with 3rd order noise shaping technology (IC701: MN 6471M).

4-1. Features and Configuration of MN6471M

- Features
1. No zero cross distortion
 2. No non linear distortion
 3. Built-in 4 times oversampling digital filter
 4. 2 channels (left and right) built in
 5. 4DAC configuration possible
 6. Single 5V power supply operation

The block diagram is shown in Fig. 9. The MN6471M is configured of a digital filter, a 3rd order noise shaping circuit, and a PWM.

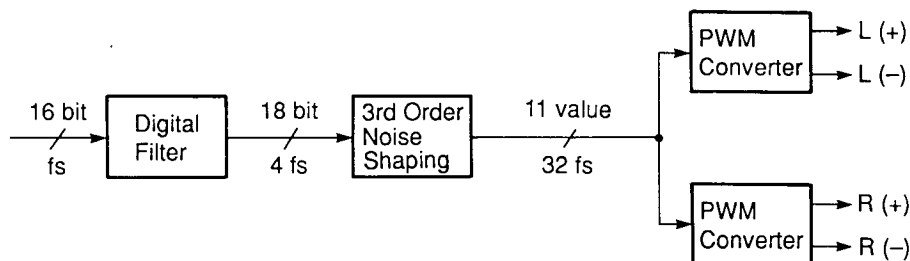

Fig. 9

4-2. Configuration of MN6471M

Fig. 10 shows the configuration of the MN6471M. The sampling frequency of the input data is expressed in f_s , so the 3rd order noise shaping circuit operates at $32f_s$. This means that a 32-times oversampling filter is required. In this LSI, however, oversampling is carried out first at $4f_s$ in the first digital filter, and following that, a 0 order hold takes place in the 3rd order noise shaping circuit. This enables conversion of the $4f_s$ signal to a $32f_s$ signal.

The digital filter, using $384f_s$ as clock signals, and the noise shaping section, uses $64f_s$, carry out time division processing on the data for the left and right channels. The PWM section, using $768f_s$ as a clock signal, carries out signal processing for the left and right channels independently.

In the noise shaping section, the 19-bit $32f_s$ signal is converted to 11 values and pulse width modulation (PWM) is carried out on these signals in the PWM section. D/A conversion is carried out in this way. Following are the descriptions of the various blocks.

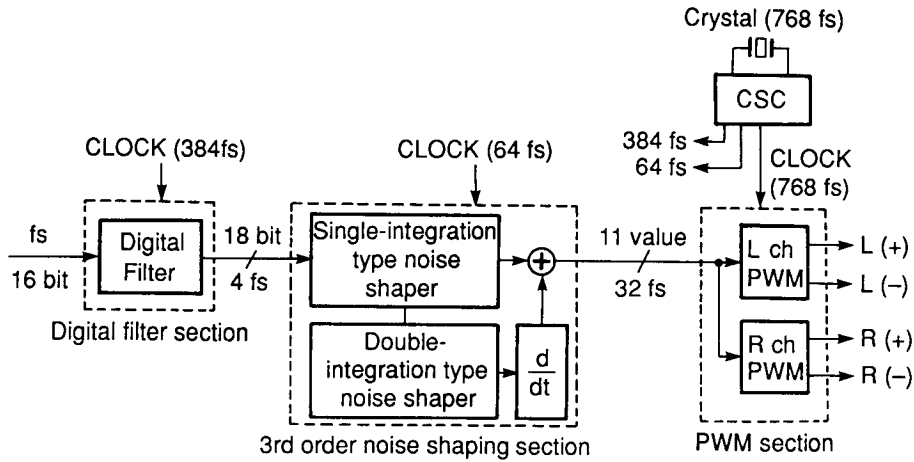

Fig. 10

5. Digital filter

Fig. 11 shows the signal data of an audio signal up to 20kHz that has been digitalized, along with the frequency distribution of the signal data. The graphs show the conditions for a sampling frequency of 44.1kHz, plus its doubled frequency, 88.2kHz, and its quadrupled frequency, 176.4kHz.

As the figure shows, for the same signal up to 20kHz, the noise portion of the digitalized signal component tends to shift toward the higher range of the signal if the sampling frequency is increased. However, at any sampling frequency, the volume of necessary audio signal information remains constant up to 20kHz. This allows certain important results to be derived; that is, if the information represented in section (a) is obtained, then it should be possible to create a signal in the form shown in (b) or (c).

When the noise caused by sampling shifts to the higher frequency range, as shown in (b) or (c), the low pass filter characteristic to eliminate noise during re-conversion to an audio signal need not be steep but can be rather gradual as shown. It is comparatively simple to provide a high audio quality low pass filter of such characteristic with little phase fluctuation or distortion.

The question now becomes how to make a signal sampled at 44.1kHz resemble one sampled at a much higher frequency. Fig. 12 shows the signal sequence sampled at the same 44.1kHz as in Fig. 11 and its frequency distribution.

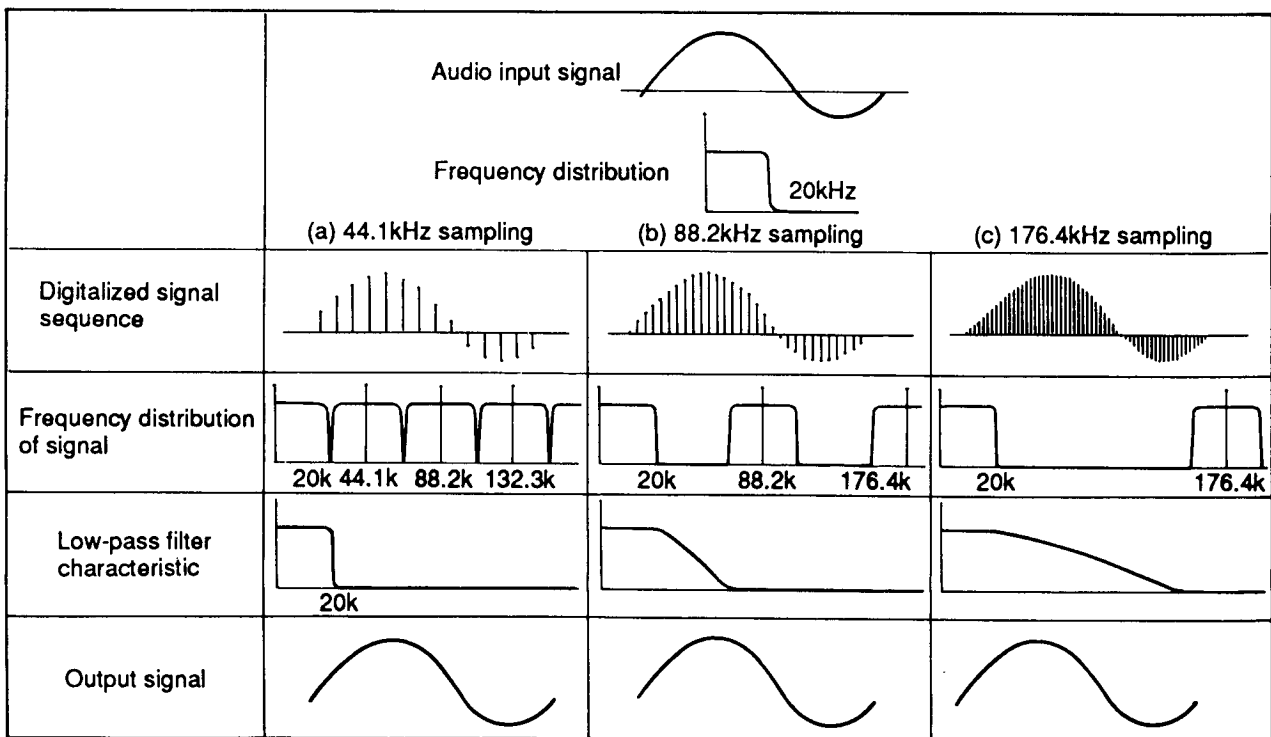

Fig. 11

If the frequency is to be doubled as the first step in increasing the sampling frequency of the signal, zero-level data is added between the data marked with X in Fig. 12(b). In the original signal sequence sampled at 44.1kHz, there are data only at the points of the sampling timing, while the intervals between those points have all been made zero-level. Introducing zero data in these intervals does not change the original data in any way, nor is the frequency distribution altered. Only the sampling frequency is doubled.

Passing this data in its modified form through a digital filter with the characteristic shown in Fig.12(c) causes the portion corresponding to N_1 to be eliminated, resulting in a signal sequence with the frequency distribution shown in (d). This signal sequence possesses exactly the same shape as that obtained for the signal in Fig. 11(b), sampled at 88.2kHz.

In other words, this method enables the sampling frequency to be doubled.

The digital filter used in this unit is a Finite Impulse Response type. Its circuit diagram is shown in Fig. 13.

The sampling frequency of this unit has been quadrupled, and the phase characteristic has been improved by using a softer analog low-pass filter.

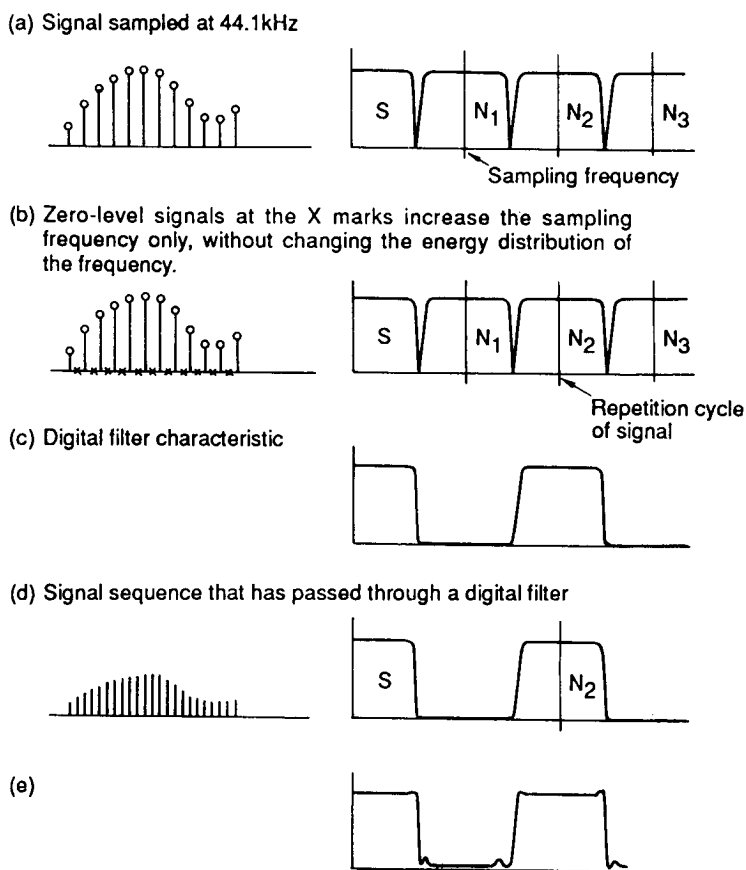

Fig. 12

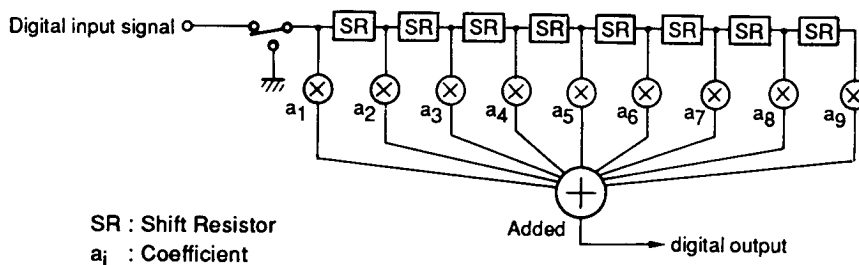

Fig. 13

6. Noise shaper

a) Single-integration noise shaper

The block diagram is shown in Fig. 14.

According to the figure, the relation between input X and output Y is as follows:

$$Y = X + (1 - Z^{-1}) Vq \dots\dots\dots (1)$$

The quantization error Vq is a random value, and (1-Z⁻¹) expresses the differential characteristic. Thus, according to equation (1), the spectrum of the quantization error Vq for the single-integration noise shaper has a characteristic of 6dB/oct, and the lower the frequency is, the greater the attenuation becomes. (This is because the noise distribution can be changed by the noise shaper).

b) Double-integration noise shaper

The block diagram is shown in Fig. 15.

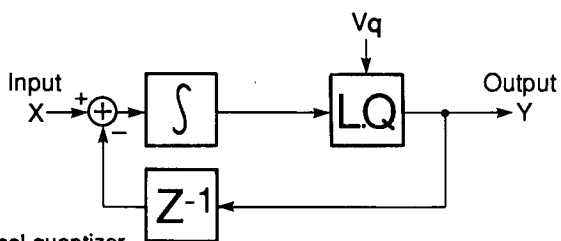

Fig. 14

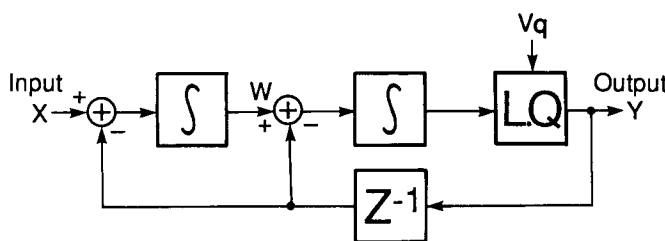

Fig. 15

LQ : Local quantizer
 Z⁻¹ : Delay
 Vq : Quantization error
 ∫ : Integrator

In Fig. 15, the path to the output seen from W has a configuration identical to that of the single-integration noise shaper, so that relation between W and Y is:

$$Y = W + (1 - Z^{-1}) Vq \dots\dots\dots (2)$$

The relation between X and Y is:

$$W = \frac{1}{1 - Z^{-1}} (X - Z^{-1}Y) \dots\dots\dots (3)$$

And the result obtained from above equations (2) and (3) is:

$$Y = X + (1 - Z^{-1})^2 Vq \dots\dots\dots (4)$$

Comparison with equation (1) shows that the term (1 - Z⁻¹) is a square of itself. In other words, with the double-integration noise shaper, the spectrum of the quantization error Vq is attenuated at a slope of 12dB/oct.

Fig. 16 shows the output spectrum of the noise shaper.

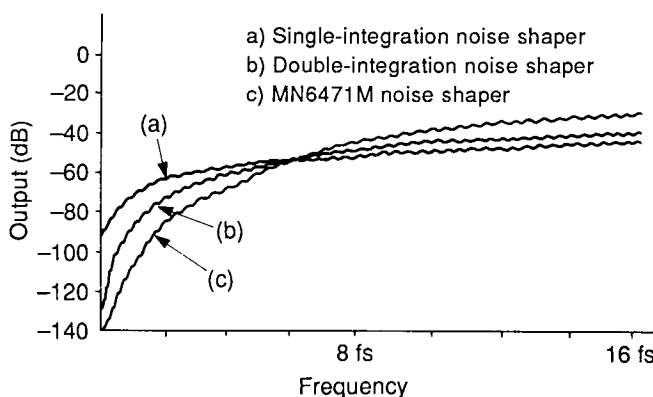

Fig. 16

6-2. 3rd order noise shaper

The block diagram of the 3rd order noise shaper is shown in Fig. 17.

This configuration shows that the first stage uses a single-integration noise shaper and the following stage uses a double-integration noise shaper. The quantization error of the first stage is input at the second stage.

In this configuration, single-integration and double-integration noise shapers are connected at several stages, and the quantization error of the previous stage is quantified again at the following stage, so that the quantization error included in the output of the previous stage is negated. In this way, compensation is carried out.

In this noise shaping circuit, the input is expressed as X, the output as Y, and the re-quantized error as Vq, and their relation for

each order is shown in the following equations.

- (1st order) $Y = X + (1 - Z^{-1}) Vq$
- (2nd order) $Y = X + (1 - Z^{-1})^2 Vq$
- (3rd order) $Y = X + (1 - Z^{-1})^3 Vq$

In noise shaping, as the order of the transfer coefficient called $(1 - Z^{-1})$ becomes larger, the noise in the 1/2 fs audio band moves higher in the frequency range. The result is that, within a narrow audio band, an 18-bit performance can be obtained even from a 1-bit DAC.

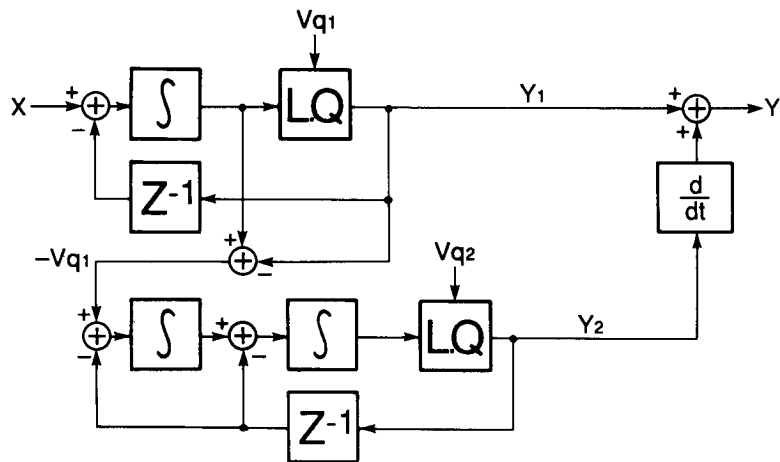

Fig. 17

$Y_1 = X + (1 - Z^{-1}) Vq_1$ (5)

$Y_2 = -Vq_1 + (1 - Z^{-1})^2 Vq_2$ (6)

$Y = Y_1 + (1 - Z^{-1}) Y_2$ (7)

The result obtained from above equations (5) ~ (7) is:

$Y = X + (1 - Z^{-1})^3 Vq_2$ (8)

7. PWM Output Section

In the output from the MN6471M noise shaper, the 11 value data of the 32fs is output. In the PWM section, pulse width modulation (PWM) is carried out on that signal, enabling D/A conversion.

Fig. 18 shows the PWM section of the MN6471M.

The 11 value digital data output from the noise shaper is converted (1-bit data stream) to pulse signal with 11 pulse widths precisely controlled by the crystal OSC and output as an analog signal. In the PWM output section, signals from both left and right channels are output as differential output so that the synchronous-phase noise is eliminated and the 2nd order high-frequency distortion is reduced.

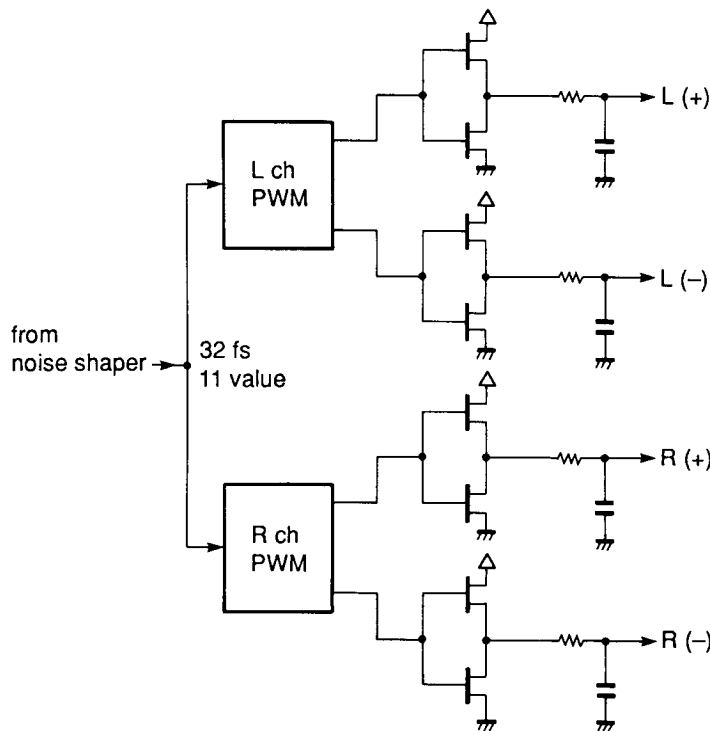

Fig. 18

8. Audio Circuit

Fig. 19 shows a block diagram of the audio circuit.

The outputs from Pin 14 (OUT L (+)) and Pin 11 OUT (-) pass through the 2-step LPF which consists of C601, R601 and R603 for one and C603, and R607 for the other, and the high frequency component of the PWM output from DAC is removed. Then the (+) side component of the PWM is inputted directly, and its (-) side componenty through the inverted darlington circuit consisting of Q301 and Q303 to the discrete circuit amplifier consisting of Q305, Q307, Q309 and Q311, where they are synthesized into an approximately 2V signal voltage which is then output to the LPF circuit of the next stage.

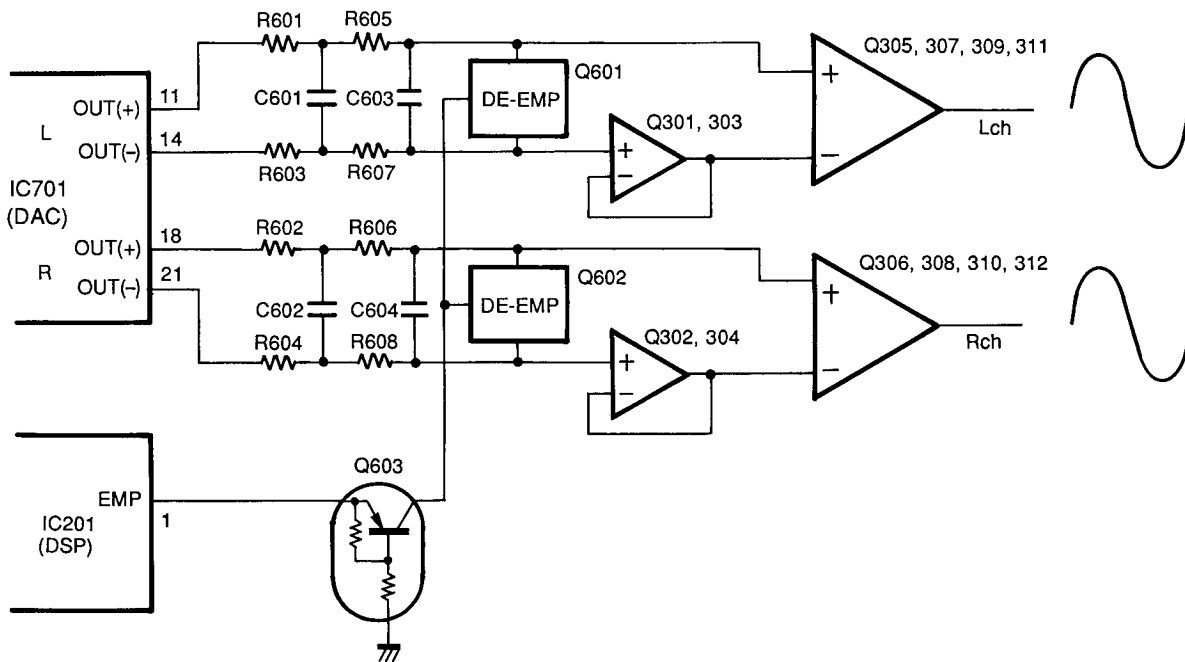

Fig 19

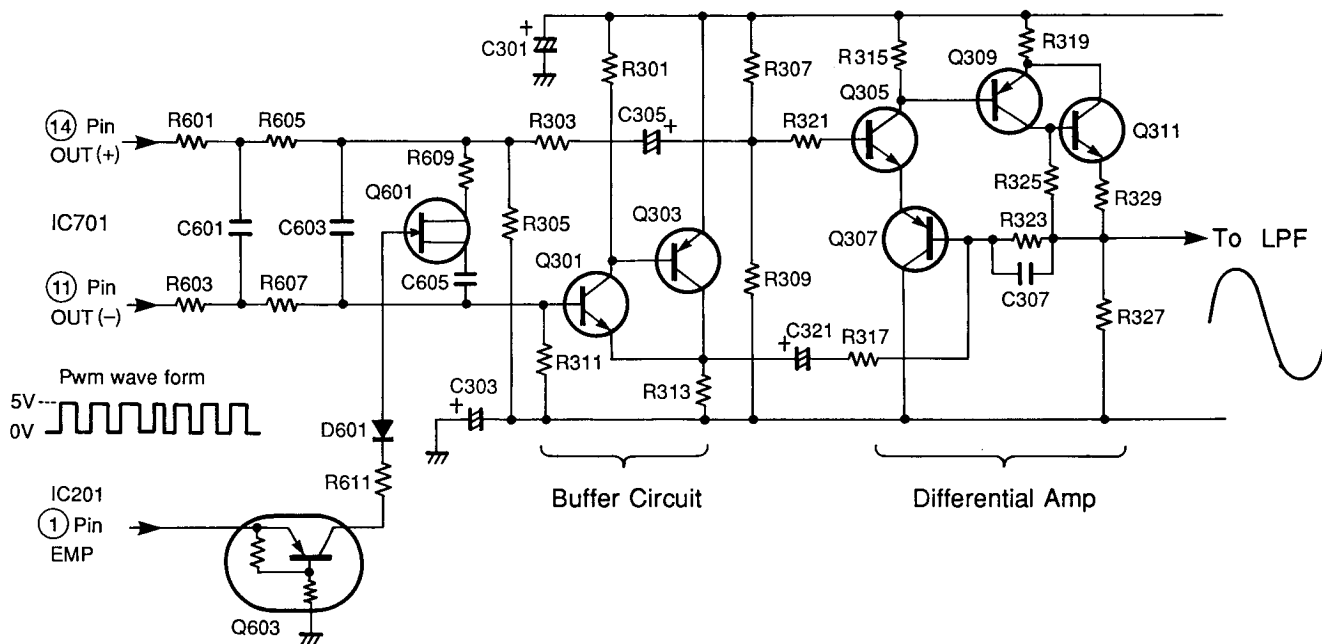

Fig. 20

The emphasis data from the disc is output through the terminal (Pin 1) of IC201. When a disc to which emphasis is applied is play back, this terminal is set high and Q603 turns ON. Following this, Q601 are also turned ON. Then connected C605 and R609 provides the DE-Emphasis characteristics. Fig. 20 shows the buffer circuit and the differential amplifier. (Light channel only)

9. Low-pass filter

Fig. 21 shows a final-stage circuit which includes a low-pass filter and other elements.

The portion of Fig. 21 enclosed by the broken line is 3rd-order active LPF. This LPF causes noise in the high range to be cut. Q313 and Q315 (Left channel) and Q314 and Q316 (Right channel) are buffer circuit of inverted darlington configuration. Q317 and Q318 are FET controlled constant current circuits. Q51, Q319, Q320, Q321 and Q322 are power muting circuit.

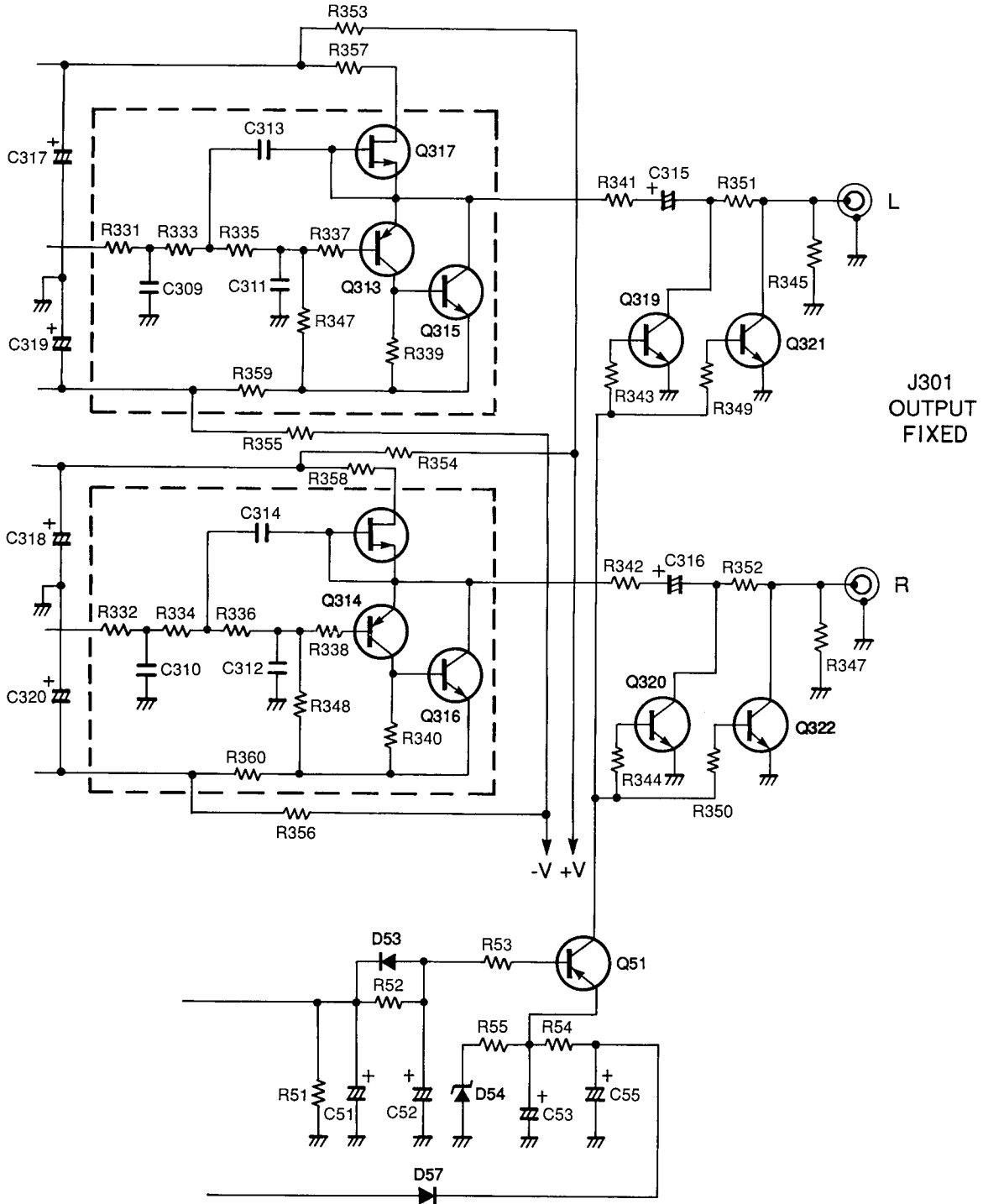
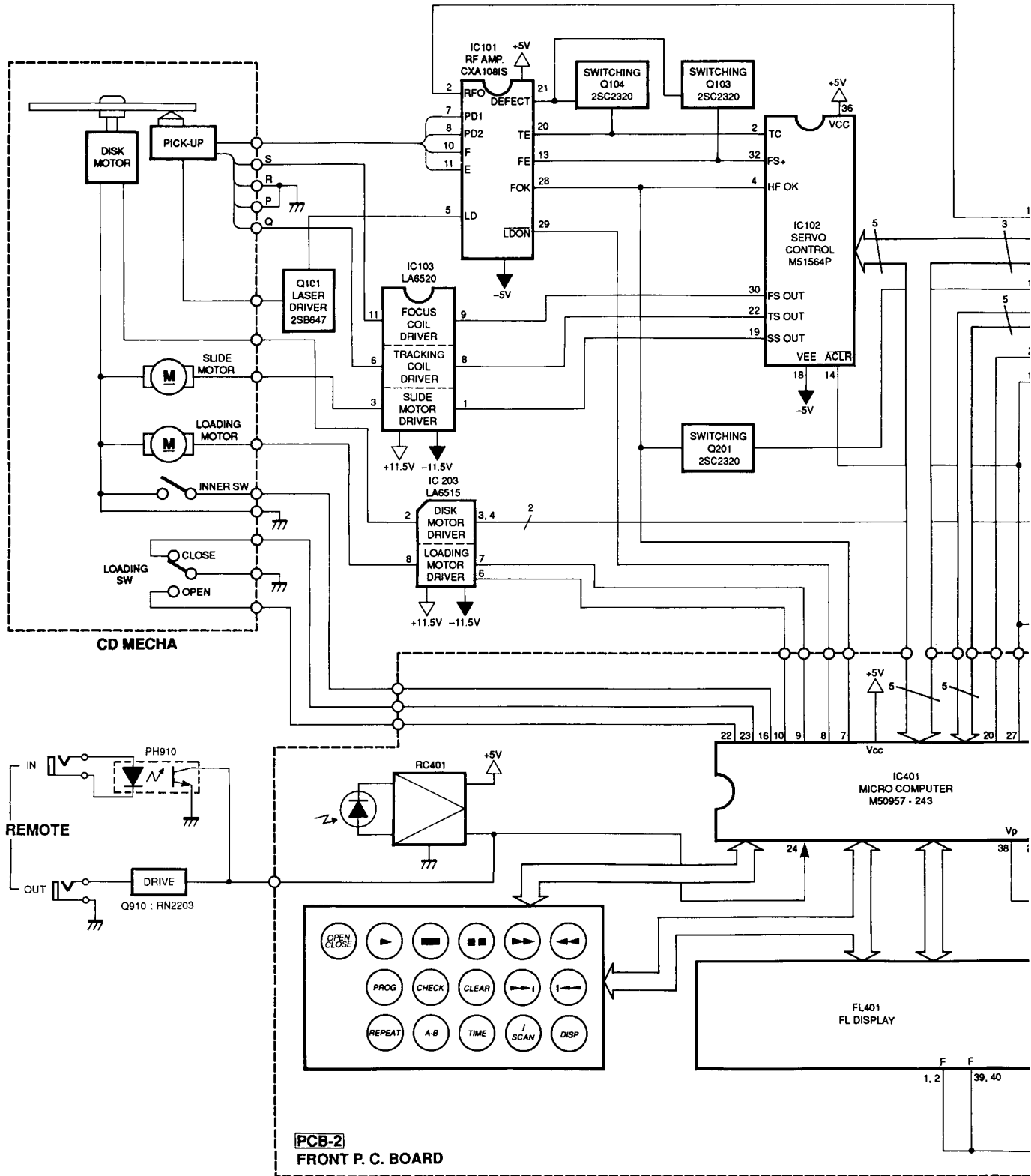
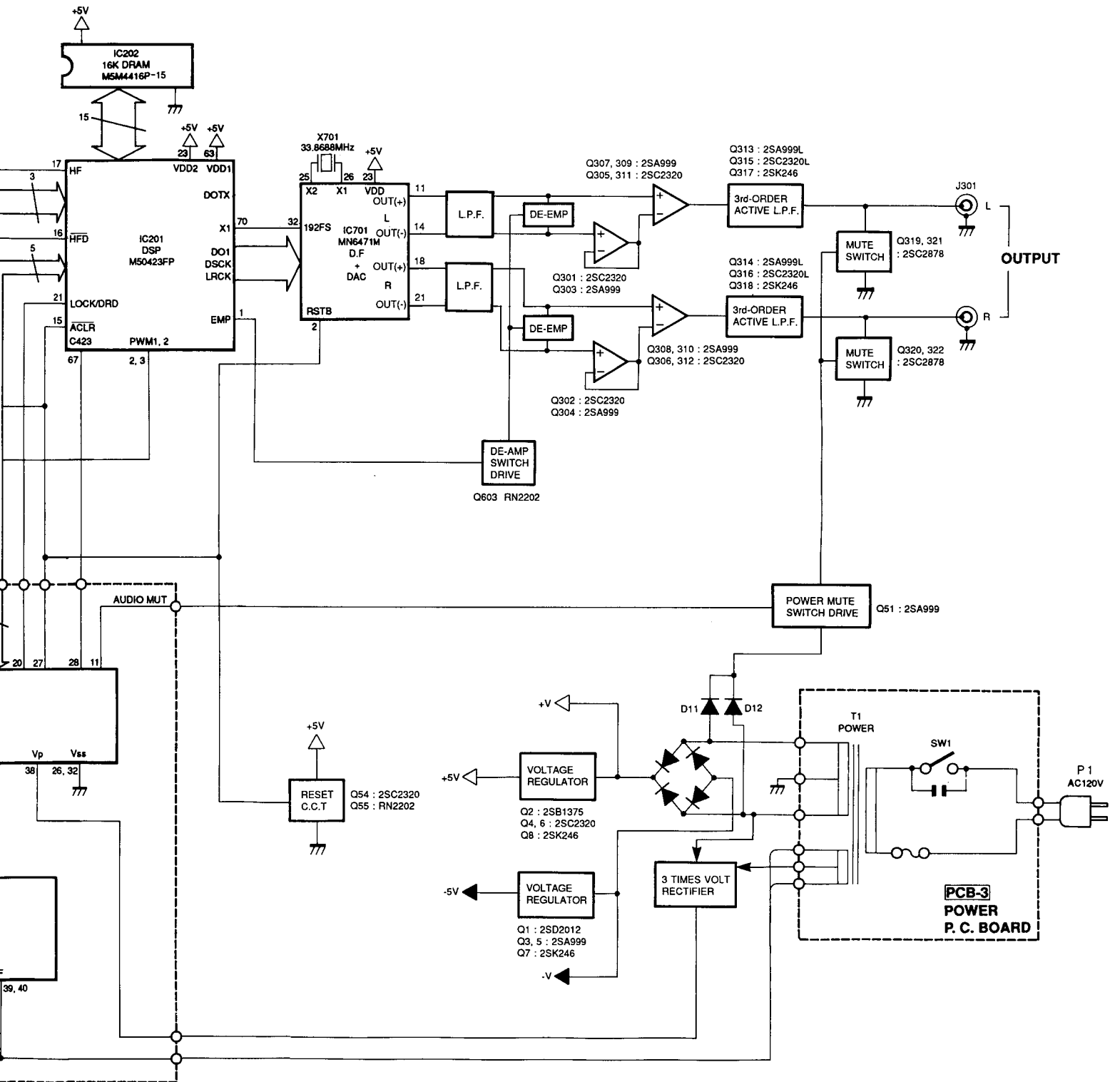

Fig. 21

BLOCK DIAGRAM



E F G H I J



GENERAL UNIT
EXPLODED VIEW

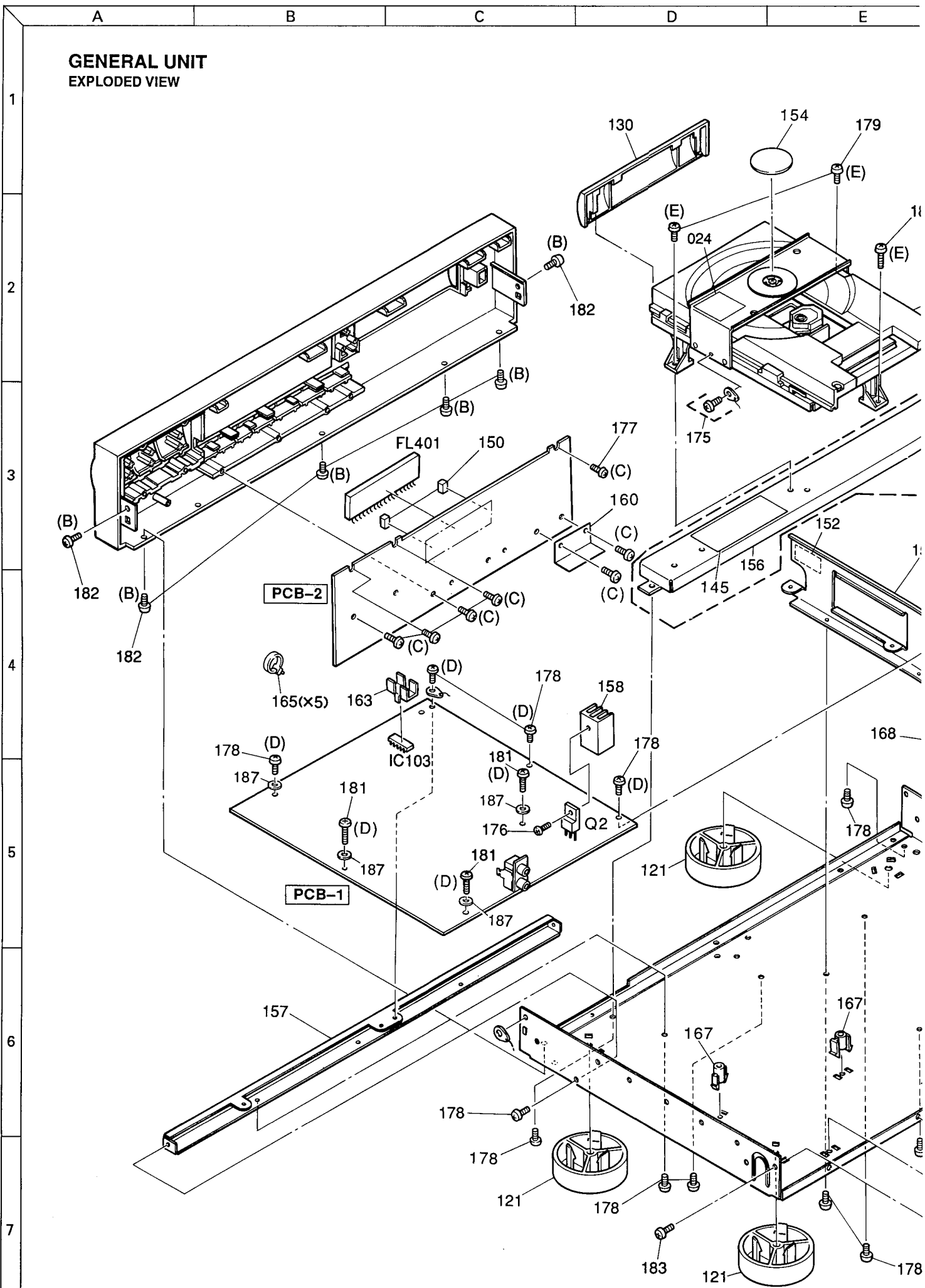

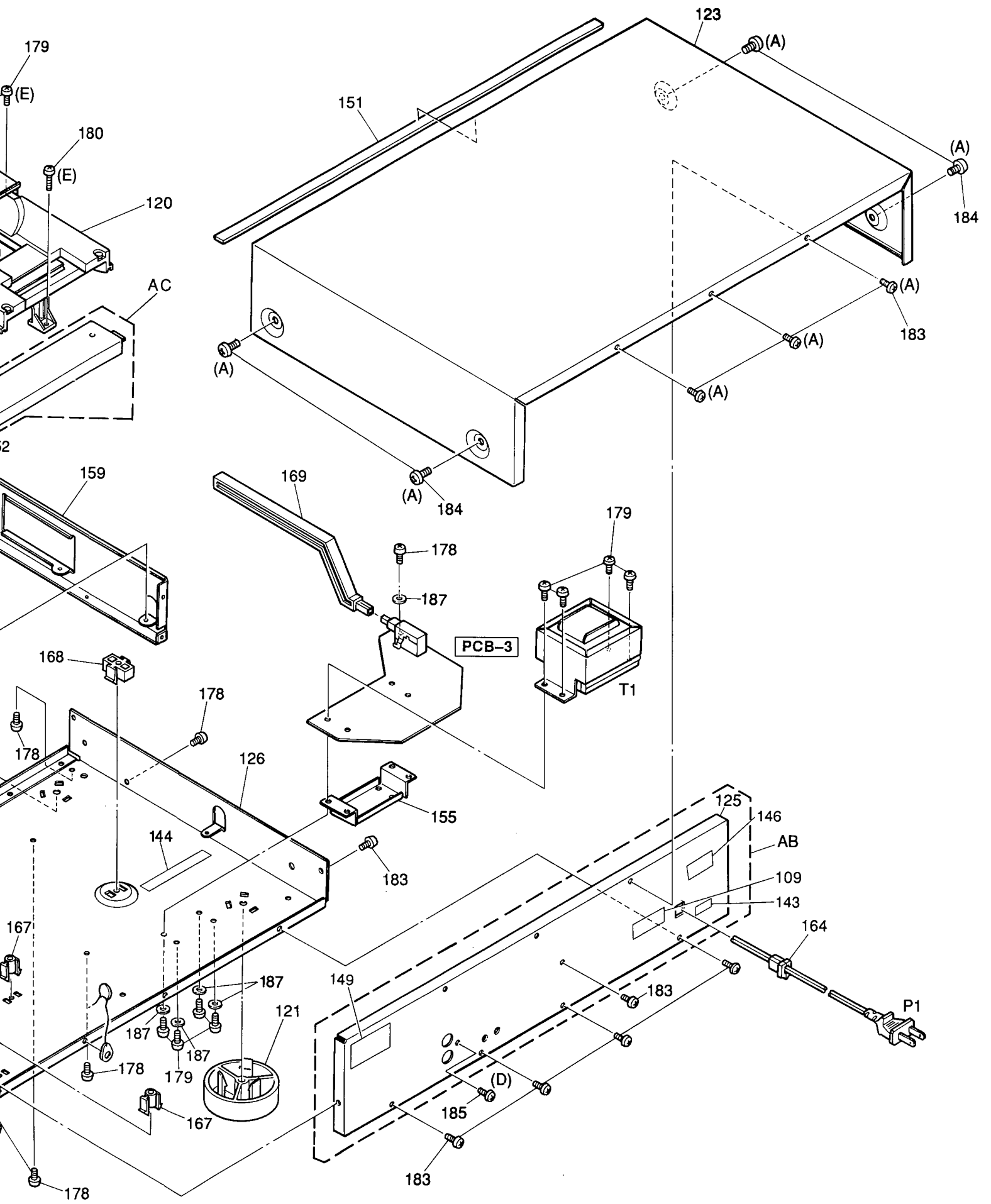

EXPLODED VIEW

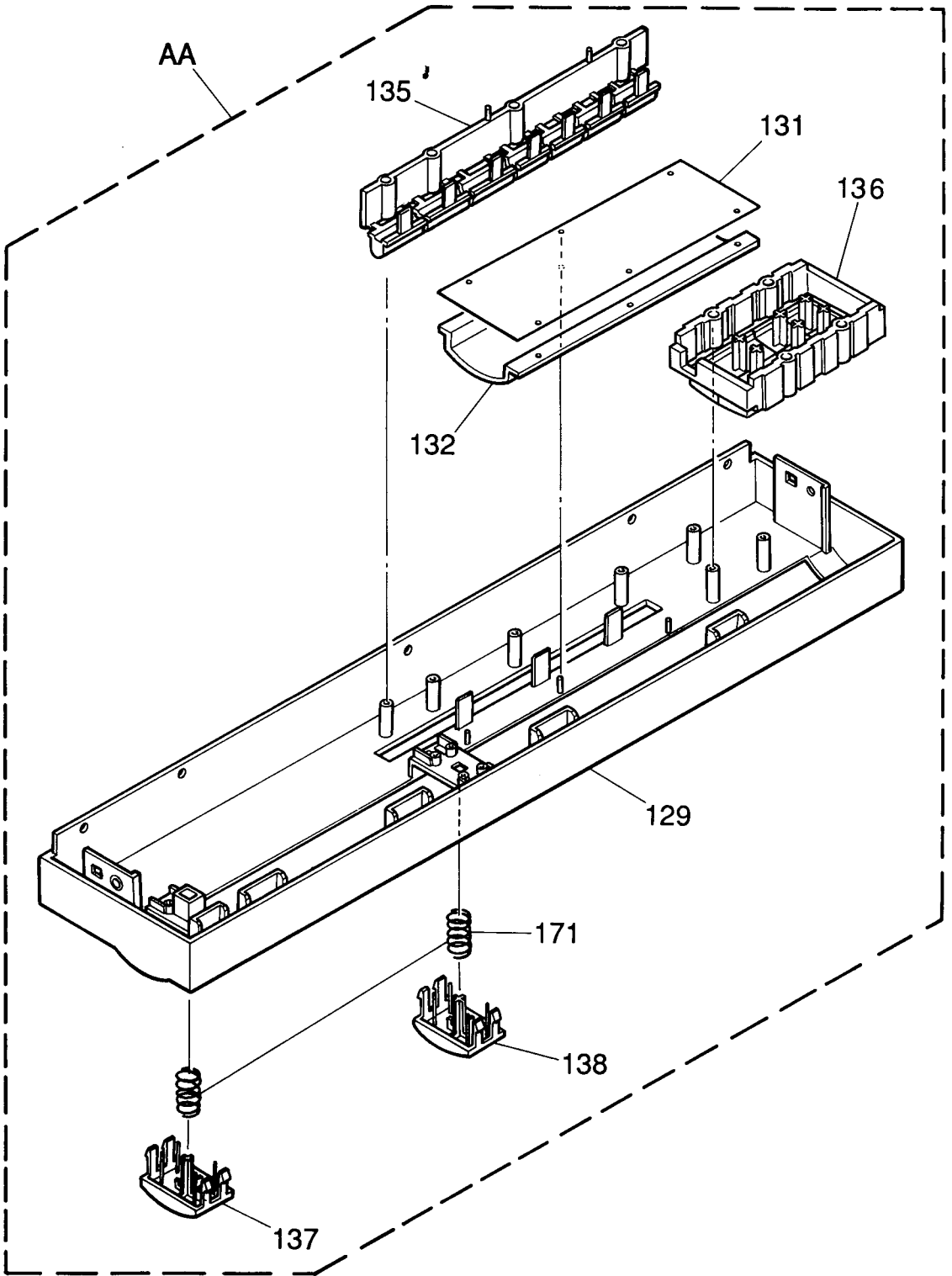

1

2

3

4

5

6

7

A

B

C

D

E

F

G

H

I

J

PARTS LIST (GENERAL UNIT)

| Ref. No. | Part No. | Description | Ref. No. | Part No. | Description |
|----------|---------------|-------------------------------------|----------|---------------|------------------------------|
| AA | A442-HD7450IA | PANEL, FRONT ASSY I | 146 | 1756-CSA | LABEL BK |
| AA | A442-HD7450IB | PANEL, FRONT ASSY BK IB BB WB | 147 | 1756-11604 | LABEL, DHHS CARD BK |
| AB | A424-HD7450IA | CABI BACK, REAR BK | 149 | 1756-11801 | LABEL, LASER WARNING |
| AB | A424-HD7450IB | CABI BACK, REAR I IB BB | 150 | 2114-86143 | BUSHING FL REAR |
| AB | A424-HD7450NB | CABI BACK, REAR WB | 151 | 2111-11769 | FELT, TOP COVER |
| AC | B219-HD7450IA | METAL FITTG, MECHA BK | 152 | 2111-1197 | FELT |
| AC | B219-HD7450IB | METAL FITTG, MECHA I IB BB WB | 154 | 2111-1422 | FELT, CD MECHA TOP |
| AD | A414-HD7450IA | CABINET, TOP | 155 | 2219-8260 | METAL FITTG, TRANS |
| 024 | 1756-11802 | LABEL I IB BB WB | 156 | 2219-8290 | METAL FITTG, MECHA |
| 109 | 1117-78 | SERIAL LABEL | 157 | 2219-8275 | METAL FITTG |
| 120 | 3119-01204 | CD MECHA | 158 | 2222-7217 | HEAT SINK, TR |
| 121 | 1319-03301 | LEG | 159 | 2219-8264 | METAL FITTG |
| 123 | 1414-14601EXP | CABINET, TOP | 160 | 2216-7194 | SHIELD PLATE, FRONT PCB |
| 125 | 1424-33003 | CABI BACK, REAR BK | 161 | 1223-00207018 | SOFT SHEET |
| 125 | 1424-33004 | CABI BACK, REAR I IB BB | 163 | 2222-7264 | HEAT SINK |
| 125 | 1424-33020 | CABI BACK, REAR WB | 164 | 2240-364 | HOLDER, AC CORD |
| 126 | 1424-29601 | CABI BACK, BOTTOM | 165 | 2240-R0101 | HOLDER, WIRING |
| 129 | 1442-25501 | PANEL, FRONT I | 167 | 2360-7021 | BOSS, SPE (x3) |
| 129 | 1442-25502 | PANEL, FRONT BK IB BB WB | 168 | 2360-7018 | BOSS, SPE |
| 130 | 1452-08302 | LID, MECHA I | 169 | 2601-7187 | SHAFT, POWER SWITCH |
| 130 | 1452-08301 | LID, MECHA BK IB BB WB | 171 | 2651-2101732 | SPRING, PUSH BUTTON |
| 131 | 1511-19803 | PLATE, FL FILTER | 176 | 2327-R0130082 | SCREW, BND+ (3x8mm) |
| 132 | 1532-17502 | WINDOW, FRONT | 177 | 2347-R0126082 | SCREW, BND T+ (2.6x8mm) (x7) |
| 135 | 1662-52103 | PUSH BUTTON, PLAY, STOP I | 178 | 2347-R0130062 | SCREW, BND T+ (3x6mm) (x14) |
| 135 | 1662-52101 | PUSH BUTTON, PLAY, STOP BK IB BB WB | 179 | 2347-R0130082 | SCREW, BND T+ (3x8mm) (x10) |
| 136 | 1662-52202 | PUSH BUTTON, FUNCTION I | 180 | 2347-R0130162 | SCREW, BND T+ (3x16mm) |
| 136 | 1662-52201 | PUSH BUTTON, FUNCTION BK IB BB WB | 181 | 2347-R0130202 | SCREW, BND T+ (3x20mm) (x3) |
| 137 | 1662-52003 | PUSH BUTTON, POWER I | 182 | 2347-R0130084 | SCREW, BND T+ (3x8mm) (x7) |
| 137 | 1662-52001 | PUSH BUTTON, POWER BK IB BB WB | 183 | 2347-R0130084 | SCREW, BND T+ (3x8mm) (x10) |
| 138 | 1662-52004 | PUSH BUTTON, OPEN/CLOSE I | 184 | 2347-R0140064 | SCREW, BND T+ (4x6mm) (x4) |
| 138 | 1662-52002 | PUSH BUTTON, OPEN/CLOSE BK IB BB WB | 185 | 2347-R0130104 | SCREW, BND T+ (3x10mm) |
| 141 | 1751-20304 | LABEL, REMOCON | 187 | 2401-035 | WASHER, METAL (x9) |
| 142 | 1751-03709 | LABEL | △ P1 | 4161-03601202 | CORD W/PLUG BK |
| 143 | 1341-568 | NAME PLATE BK | △ P1 | 4161-03701220 | CORD W/PLUG I IB BB |
| 144 | 1756-03305 | LABEL, LASER CAUTION | △ P1 | 4161-7256 | CORD W/PLUG WB |
| 145 | 1756-09602 | LABEL, LASER CAUTION BK | △ T1 | 5584-S8801 | XFORMER, POWER BK |
| 145 | 1756-12101 | LABEL, LASER CAUTION I IB BB WB | △ T1 | 5584-S8802 | XFORMER, POWER I IB BB WB |

A B C D E

CD MECHANISM EXPLODED VIEW

1
2
3
4
5
6
7

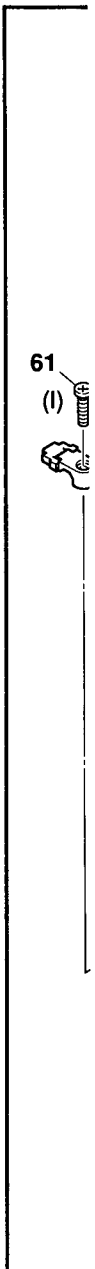
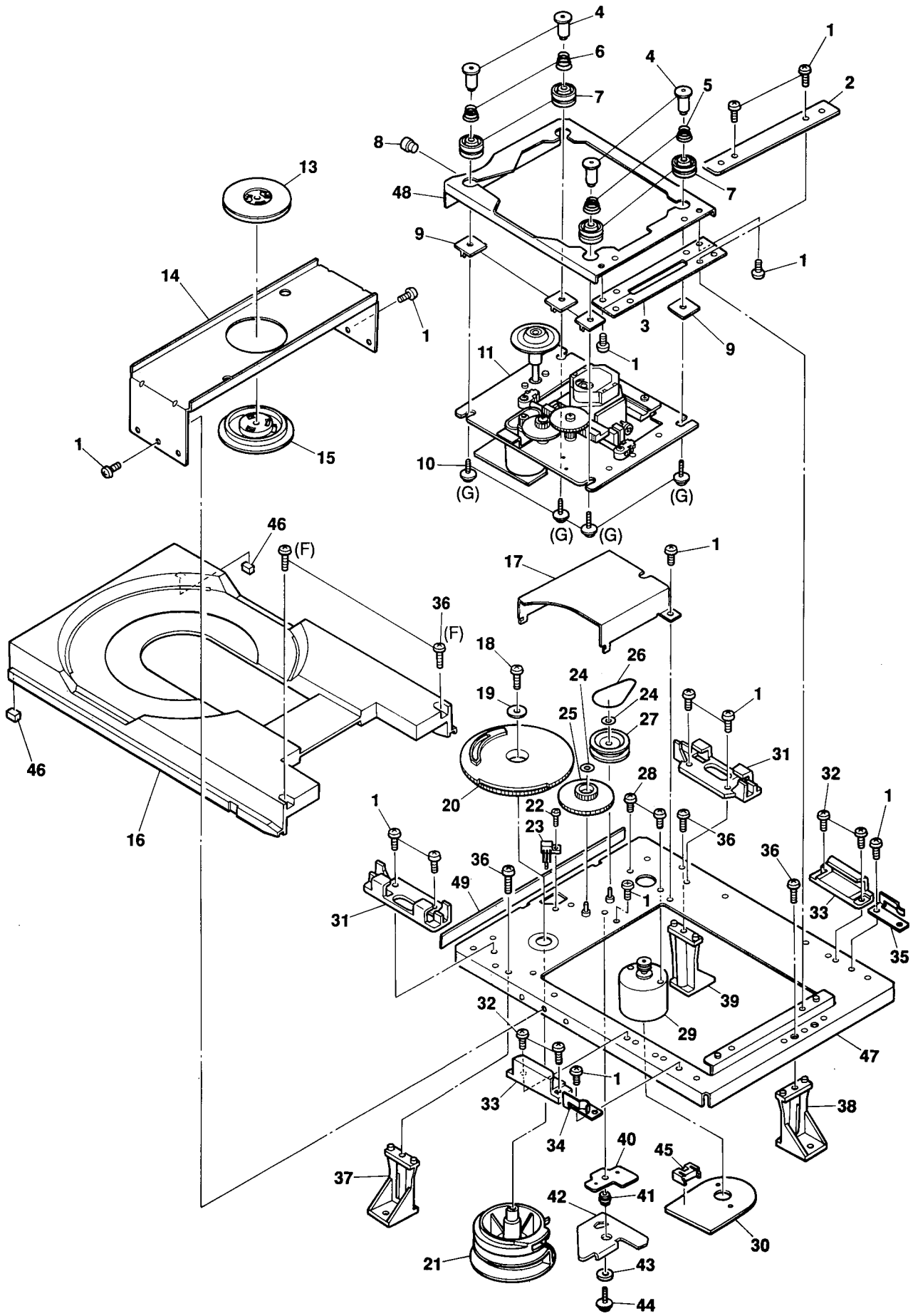

PARTS LIST

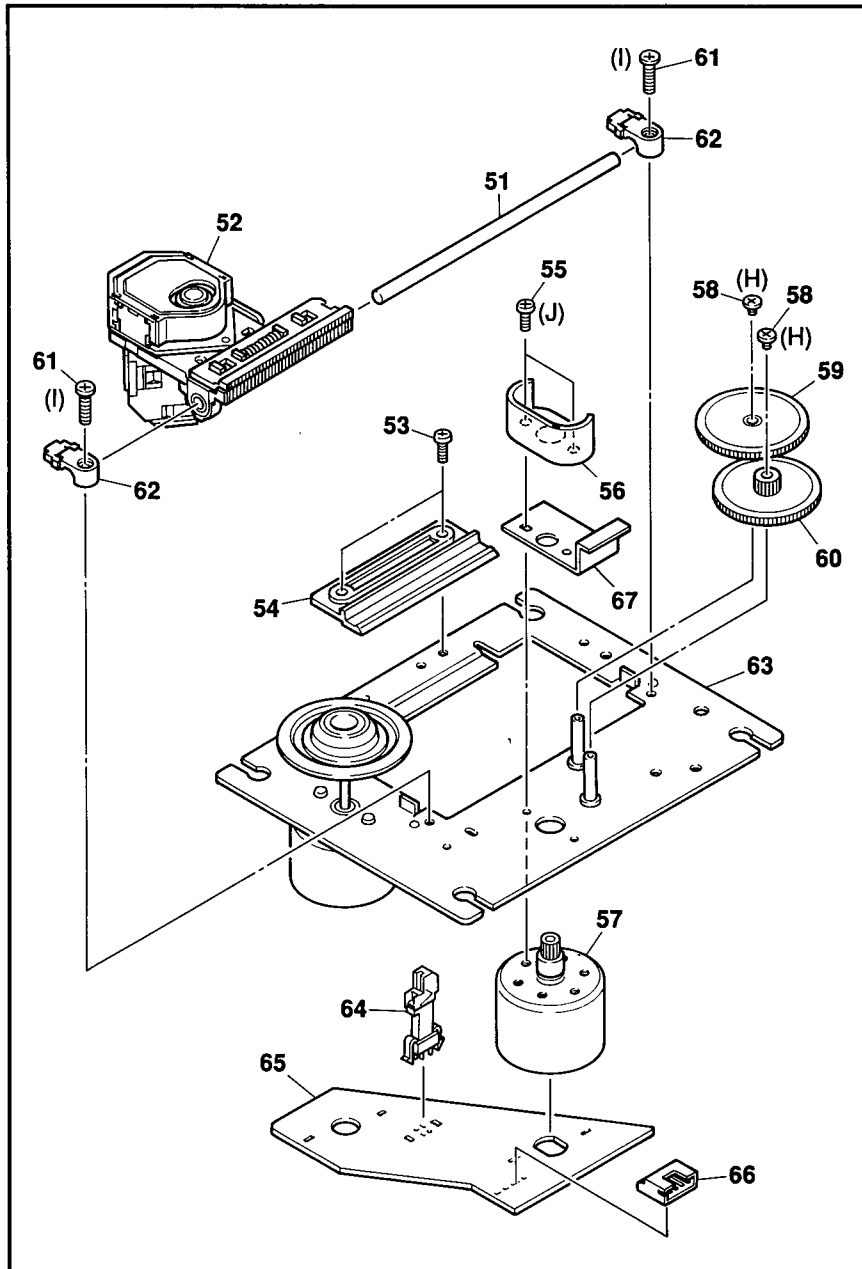

| Ref. No. | Part No. | Description |
|----------|----------------|--------------------------|
| 1 | 7-685-862-(01) | SCREW (+)(2.6x6mm) |
| 2 | 2-642-170-(01) | HINGE HOLDER |
| 3 | 2-642-164-(01) | HINGE |
| 4 | 2-642-160-(01) | SHAFT |
| 5 | 2-642-137-(02) | COIL SPRING (B) |
| 6 | 2-642-139-(02) | COIL SPRING (A) |
| 7 | 2-642-158-(01) | INSULATOR (C) |
| 8 | 2-642-169-(02) | ROLLER |
| 9 | 2-642-159-(01) | PLATE (T) |
| 10 | 2-642-142-(01) | SCREW |
| 11 | 8-848-184-(01) | CD PLAYER SUB UNIT ASSY |
| 13 | X-2642-108-(1) | MAGNET ASSY |
| 14 | 2-642-165-(01) | CHUCK CHASSIS |
| 15 | 2-642-181-(01) | CHUCKING PULLEY |
| 16 | 2-642-156-(02) | TRAY |
| 17 | 2-642-149-(02) | GEAR COVER |
| 18 | 7-685-535-(19) | SCREW (+)(2.6x10mm) |
| 19 | 4-812-554-(01) | WASHER |
| 20 | 2-642-154-(03) | DRIVE GEAR |
| 21 | 2-642-153-(01) | CONTROL CAM |
| 22 | 7-685-851-(01) | SCREW (+)(2x4mm) |
| 23 | 1-572-052-(11) | LEAF SWITCH |
| 24 | 3-558-708-(21) | LOCK WASHER |
| 25 | 2-642-148-(01) | CENTER GEAR |
| 26 | 3-653-387-(01) | LM BELT |
| 27 | 4-913-731-(01) | LOADING PULLEY |
| 28 | 7-621-775-(00) | SCREW (+)(2.6x3mm) |
| 29 | X-2641-336-(1) | MOTOR ASSY |
| 30 | 1-624-793-(21) | MOTOR P. C. BOARD |
| 31 | 2-642-161-(01) | TRAY HOLDER, FRONT |
| 32 | 7-685-781-(01) | SCREW (+)(2x4mm) |
| 33 | 2-642-162-(03) | TRAY HOLDER, REAR |
| 34 | 2-642-146-(02) | TRAY GUIDE, RIGHT |
| 35 | 2-642-147-(02) | TRAY GUIDE, LEFT |
| 36 | 7-685-547-(19) | SCREW (+)(3x10mm) |
| 37 | 2-642-510-(01) | HOLDER, RIGHT |
| 38 | 2-642-512-(01) | HOLDER, REAR |
| 39 | 2-642-511-(01) | HOLDER, LEFT |
| 40 | 2-642-173-(01) | LINK PLATE |
| 41 | 2-642-133-(02) | BOSS |
| 42 | X-2642-109-(1) | STOPPER LINK ASSY |
| 43 | 2-642-172-(01) | SPACER |
| 44 | 7-682-902-(31) | SCREW (+)(2.6x8mm) |
| 45 | 1-564-721-(11) | CONNECTOR, 5 PIN |
| 46 | 2-642-125-(01) | DAMPER |
| 47 | X-2642-106-(2) | MAIN CHASSIS ASSY |
| 48 | X-2642-105-(2) | SUB CHASSIS ASSY |
| 49 | 2-642-157-(03) | FRONT TAPE |
| 51 | 4-910-431-(02) | SLIDE SHAFT |
| 52 | 8-848-127-(31) | PICK-UP ASSY |
| 53 | 2-641-386-(01) | SPECIAL SCREW (2x5mm) |
| 54 | 2-641-443-(02) | SLIDE HOLDER |
| 55 | 7-621-255-(35) | SCREW (+)(2x5mm) |
| 56 | 2-641-434-(01) | GEAR COVER |
| 57 | X-2641-358-(1) | SLIDE MOTOR ASSY |
| 58 | 3-303-809-(31) | SPECIAL SCREW (M1.7x3mm) |
| 59 | 2-641-404-(02) | GEAR (A) |
| 60 | 2-641-403-(06) | GEAR (B) |
| 61 | 2-641-447-(01) | SCREW (+)(2.6x8mm) |
| 62 | 2-641-448-(02) | SHAFT CLAMP |
| 63 | X-2641-356-(1) | DISC MOTOR ASSY |
| 64 | 1-570-053-(12) | LEAF SWITCH |
| 65 | 1-628-263-(11) | MOTOR P. C. BOARD |
| 66 | 1-564-720-(11) | CONNECTOR, 4 PIN |
| 67 | 2-641-371-(01) | STOPPER |

P. C. BOARDS

PCB-3 POWER SWITCH P. C. BOARD

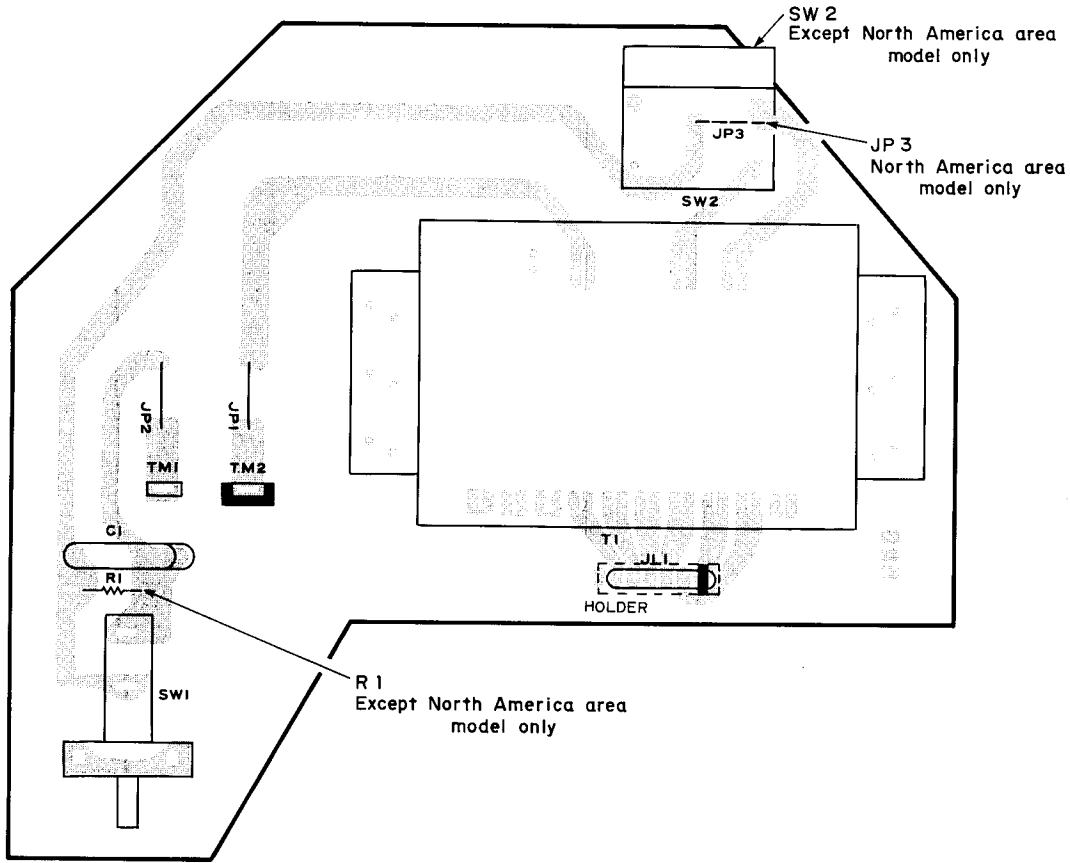

SW 2
Except North America area
model only

JP 3
North America area
model only

R 1
Except North America area
model only

TP401

TP203

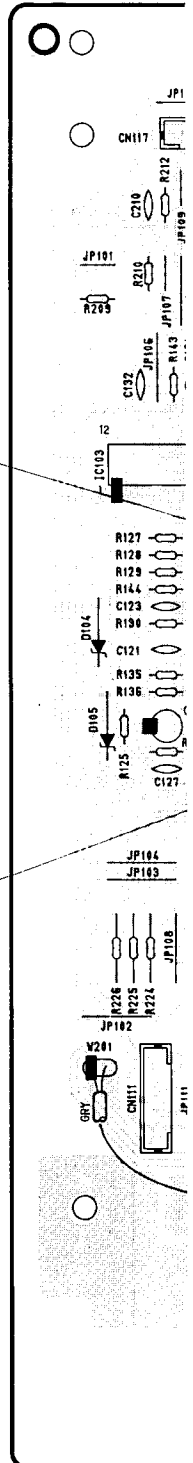

PCB-1 MAIN P. C. BOARD

FOCUS OFFSET
ADJ.

EF BALANCE
ADJ.

OPTICAL PICK-UP LASER POWER
ADJUSTMENT

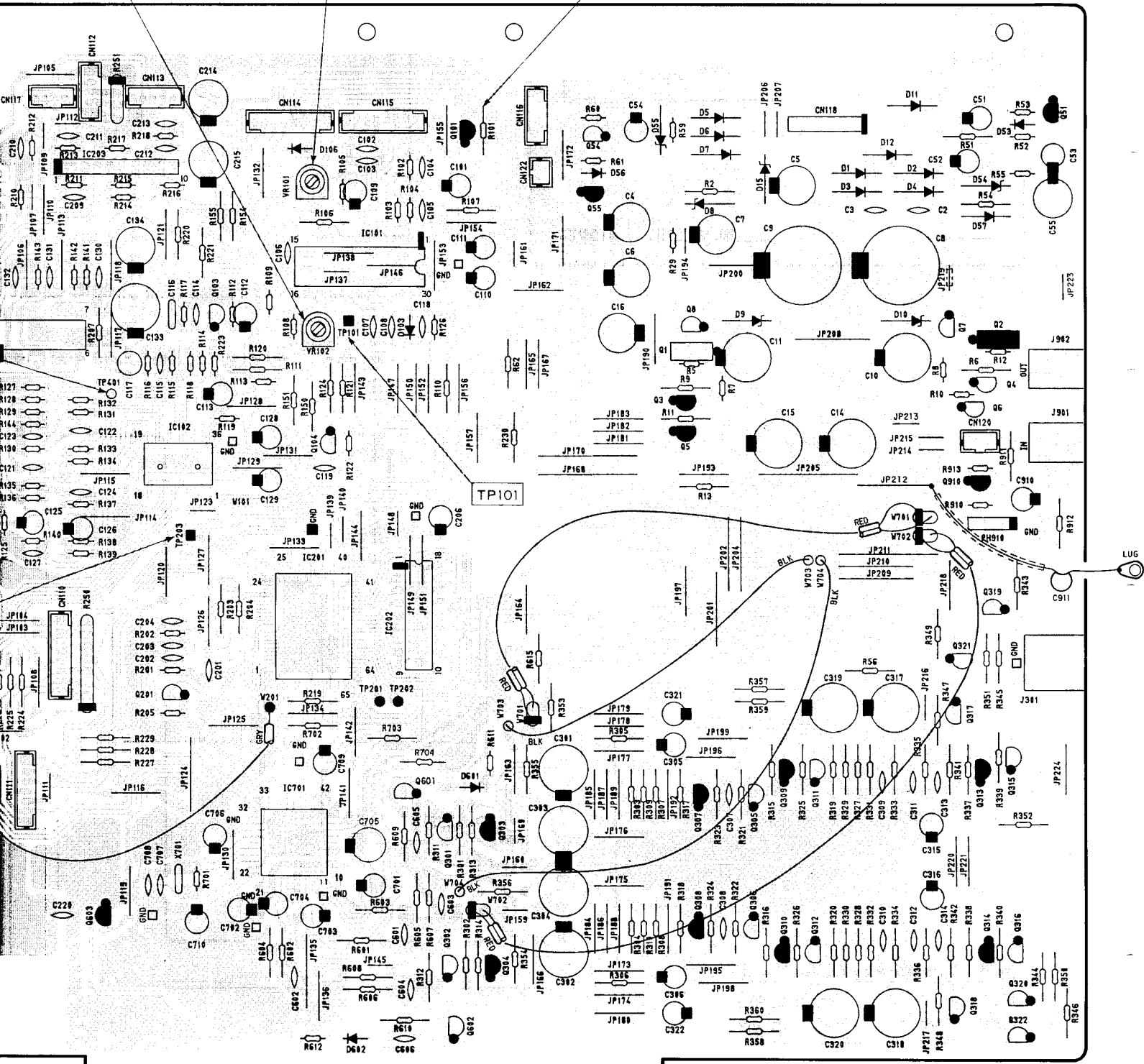

A

B

C

D

E

P. C. BOARDS

PCB-2 FRONT P. C. BOARD

1

2

3

4

5

6

7

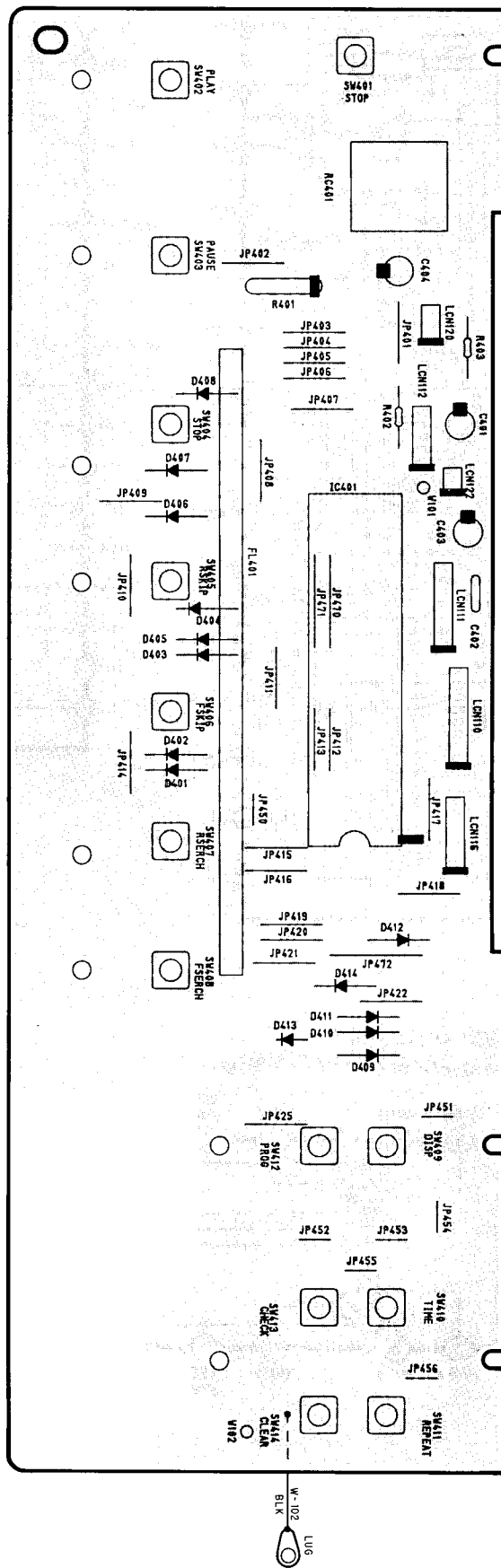

IC BLOCK DIAGRAM

IC101 : CXA1081S
RF Amp.

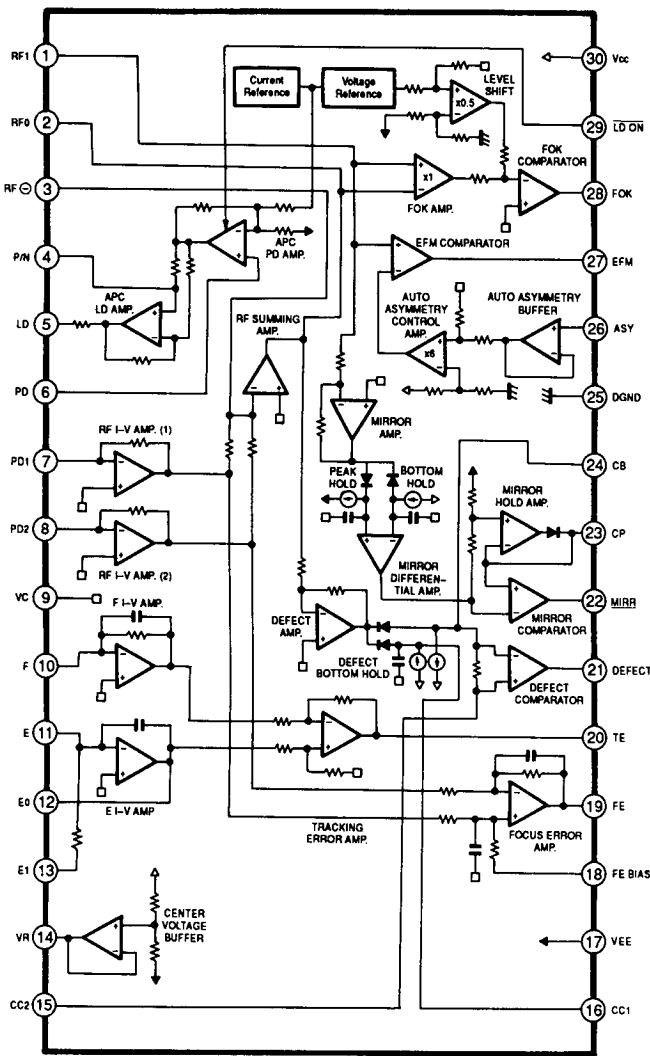

IC102
M51564P
Optical Pick-up Servo Control

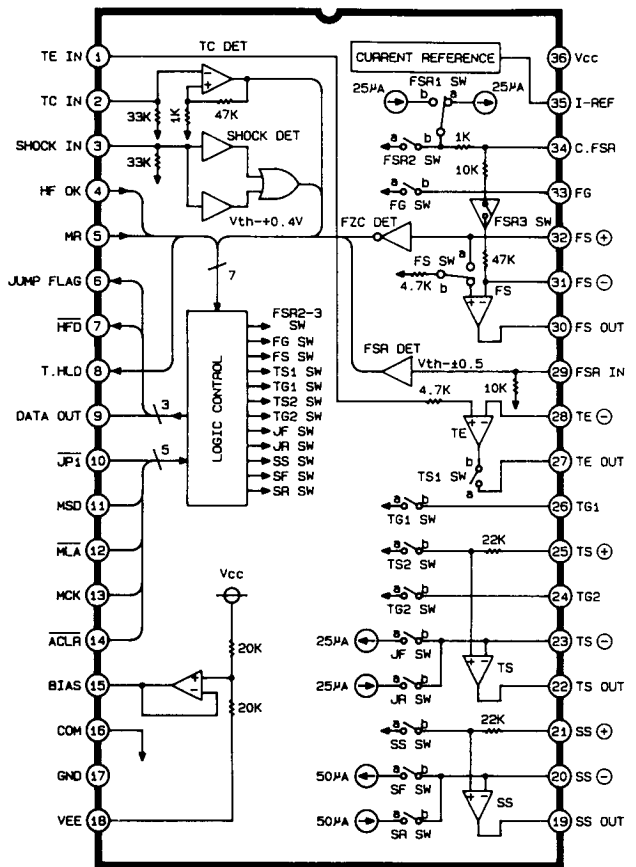

IC103 : LA6520
3 channel Power OP-Amp.

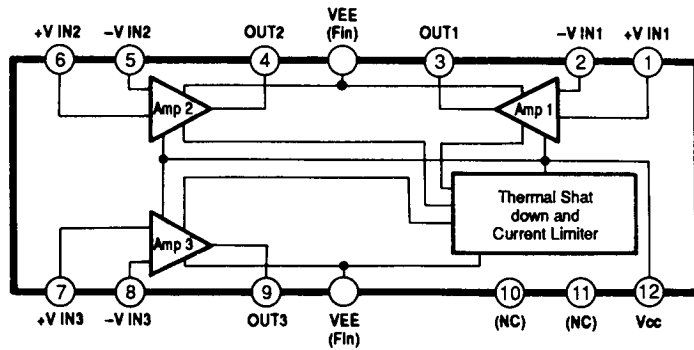

IC201 : M50423FP
Digital Signal Processor

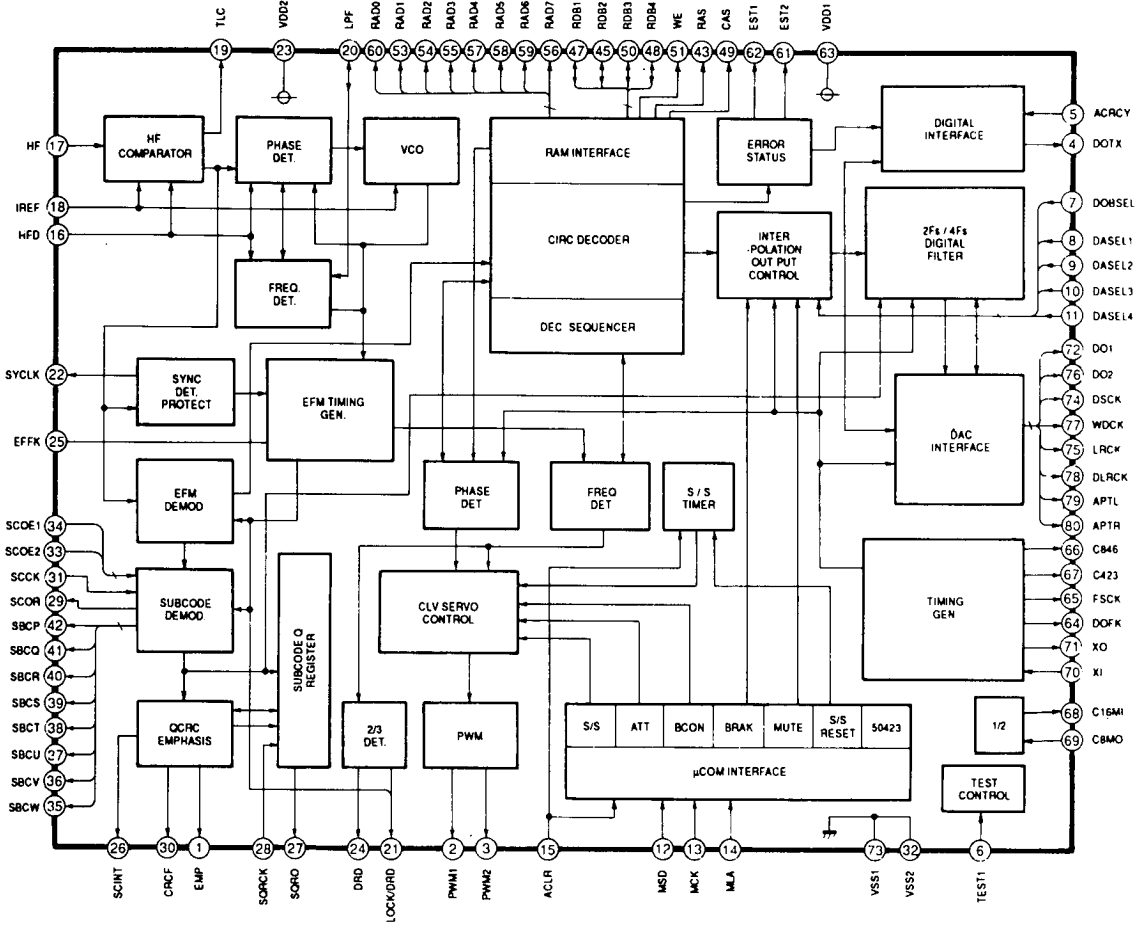

IC202
M5M4416P-15
65536-Bit (16384-Word by 4-Bit)
Dynamic RAM

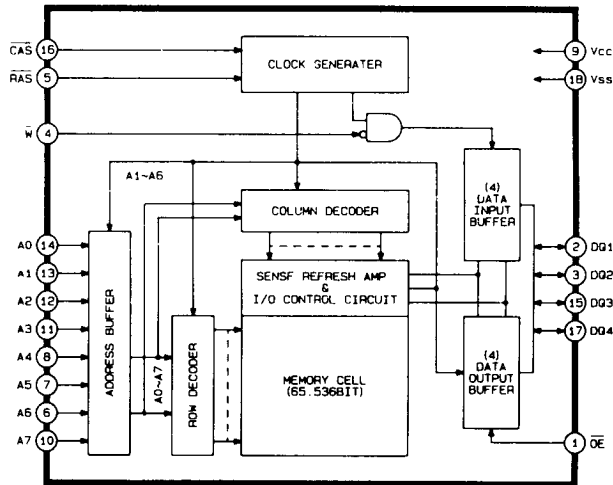

IC203 : LA6515
2 channel Power OP-Amp.

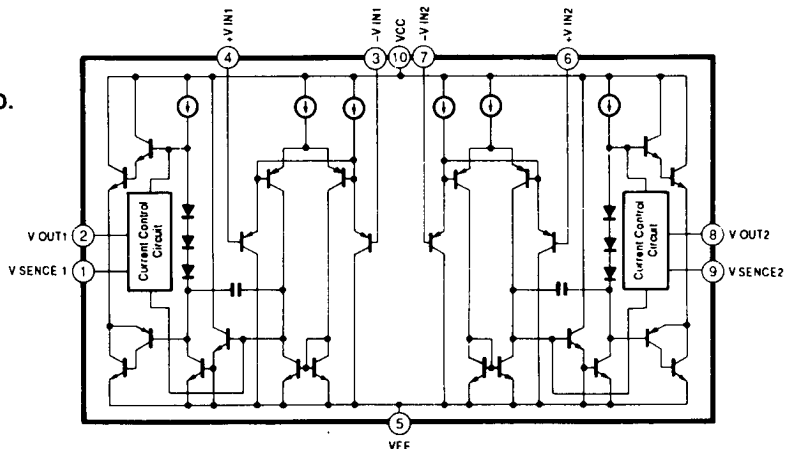

IC401 : M50957-243
Microcomputer

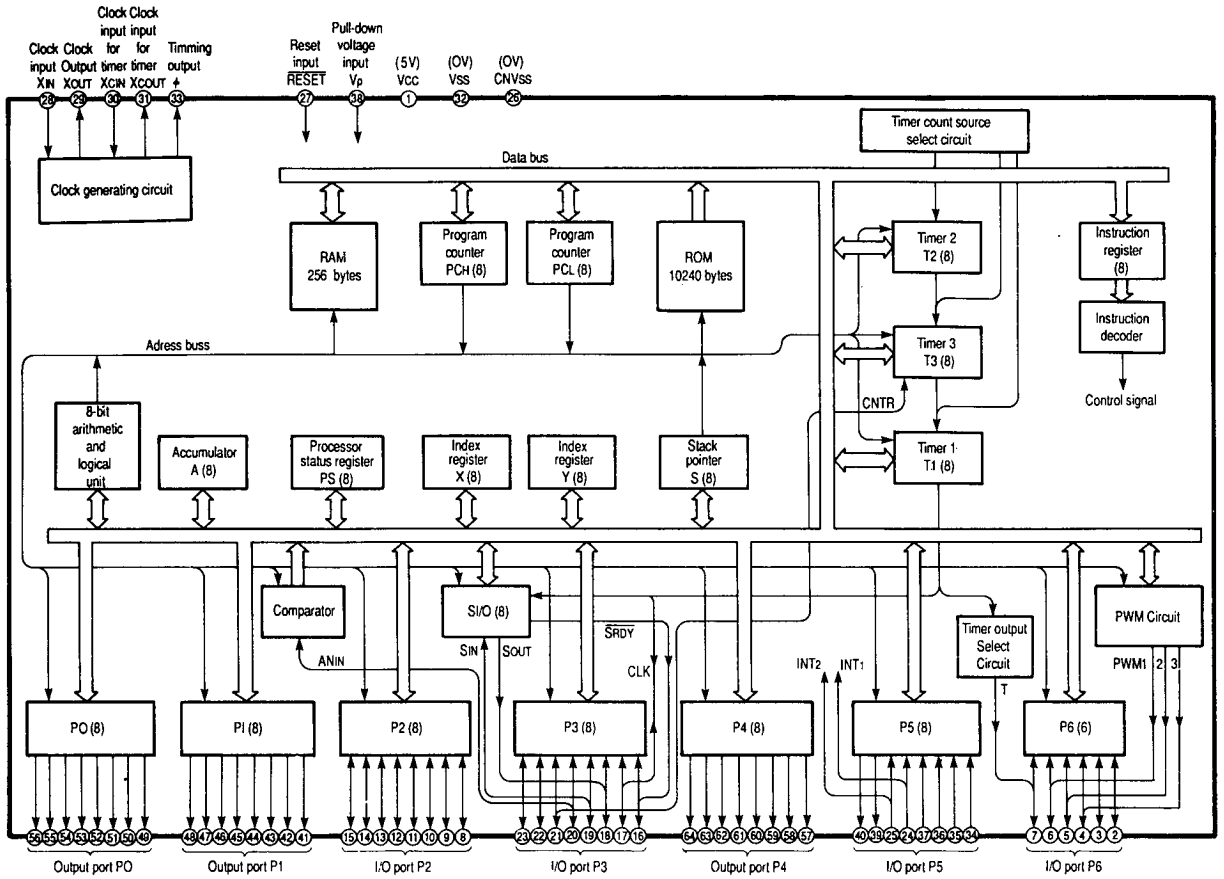

IC701 : MN6471M
Digital Filter & D/A Converter

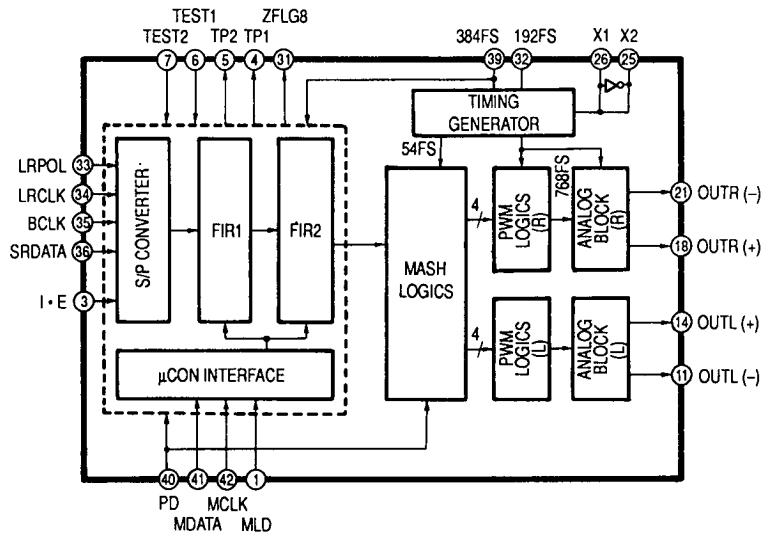

PARTS LIST

| Ser.No | Ref. No. | Part No. | Description | Ser.No | Ref. No. | Part No. | Description |
|------------------------------|----------|---------------|--------------------------------|------------------|----------|---------------|------------------------------|
| PCB-1 MAIN P.C. BOARD | | | | | | | |
| CAPACITORS | | | | | | | |
| 512 | C2 | 5354-104593 | CAP, MYL .1 μ | 690 | C304 | 5345-S06DM227 | CAP, MINI ELE 220 μ 25V |
| 512 | C3 | 5354-104593 | CAP, MYL .1 μ | 688 | C305 | 5345-106C0951 | CAP, MINI ELE 10 μ 16V |
| 507 | C4 | 5345-107E0962 | CAP, MINI ELE 100 μ /35V | 688 | C306 | 5345-106C0951 | CAP, MINI ELE 10 μ 16V |
| 509 | C5 | 5345-227C0962 | CAP, MINI ELE 220 μ 16V | 694 | C307 | 5353-100534 | CAP, MCA 10p |
| 507 | C6 | 5345-107E0962 | CAP, MINI ELE 100 μ /35V | 694 | C308 | 5353-100534 | CAP, MCA 10p |
| 507 | C7 | 5345-107E0962 | CAP, MINI ELE 100 μ /35V | 692 | C309 | 5359-1525851 | CAP, PPP 1500p |
| 511 | C8 | 5345-478C0962 | CAP, MINI ELE 4700 μ /16V | 692 | C310 | 5359-1525851 | CAP, PPP 1500p |
| 511 | C9 | 5345-478C0962 | CAP, MINI ELE 4700 μ /16V | 692 | C311 | 5359-1525851 | CAP, PPP 1500p |
| 509 | C10 | 5345-227C0962 | CAP, MINI ELE 220 μ /16V | 692 | C312 | 5359-1525851 | CAP, PPP 1500p |
| 509 | C11 | 5345-227C0962 | CAP, MINI ELE 220 μ /16V | 693 | C313 | 5359-5625851 | CAP, PPP 5600p |
| 510 | C14 | 5345-108A0962 | CAP, MINI ELE 1000 μ /6.3V | 693 | C314 | 5359-5625851 | CAP, PPP 5600p |
| 510 | C15 | 5345-108A0962 | CAP, MINI ELE 1000 μ /6.3V | 689 | C315 | 5345-107B0951 | CAP, MINI ELE 100 μ /10V |
| 507 | C16 | 5345-107E0962 | CAP, MINI ELE 100 μ /35V | 689 | C316 | 5345-107B0951 | CAP, MINI ELE 100 μ /10V |
| 775 | C51 | 5345-226D0962 | CAP, MINI ELE 22 μ /25V | 691 | C317 | 5345-S06BM107 | CAP, MINI ELE 100 μ /10V |
| 779 | C52 | 5345-106C0962 | CAP, MINI ELE 10 μ /16V | 691 | C318 | 5345-S06BM107 | CAP, MINI ELE 100 μ /10V |
| 775 | C53 | 5345-226D0962 | CAP, MINI ELE 22 μ /25V | 691 | C319 | 5345-S06BM107 | CAP, MINI ELE 100 μ /10V |
| 777 | C54 | 5345-227B0962 | CAP, MINI ELE 220 μ /10V | 691 | C320 | 5345-S06BM107 | CAP, MINI ELE 100 μ /10V |
| 776 | C55 | 5345-477C0962 | CAP, MINI ELE 470 μ /16V | 687 | C321 | 5345-336B0951 | CAP, MINI ELE 33 μ /10V |
| 589 | C101 | 5345-107B0962 | CAP, MINI ELE 100 μ /10V | 687 | C322 | 5345-336B0951 | CAP, MINI ELE 33 μ /10V |
| 577 | C102 | 5361-100DSL | CAP, CER 10p | 696 | C601 | 5353-820534 | CAP, MCA 82p |
| 577 | C103 | 5361-100DSL | CAP, CER 10p | 696 | C602 | 5353-820534 | CAP, MCA 82p |
| 578 | C104 | 5361-100DCH | CAP, CER 10p | 695 | C603 | 5353-330534 | CAP, MCA 33p |
| 582 | C105 | 5361-332KB | CAP, CER 3300p | 695 | C604 | 5353-330534 | CAP, MCA 33p |
| 572 | C106 | 5369-333144 | CAP, SCD .033 μ | 697 | C605 | 5359-1525851 | CAP, PPP 1500p |
| 572 | C107 | 5369-333144 | CAP, SCD .033 μ | 697 | C606 | 5359-1525851 | CAP, PPP 1500p |
| 571 | C108 | 5369-103144 | CAP, SCD .01 μ | 746 | C701 | 5345-S06BM107 | CAP, MINI ELE 100 μ /10V |
| 588 | C109 | 5345-476B0962 | CAP, MINI ELE 47 μ /10V | 746 | C702 | 5345-S06BM107 | CAP, MINI ELE 100 μ /10V |
| 588 | C110 | 5345-476B0962 | CAP, MINI ELE 47 μ /10V | 746 | C703 | 5345-S06BM107 | CAP, MINI ELE 100 μ /10V |
| 588 | C111 | 5345-476B0962 | CAP, MINI ELE 47 μ /10V | 746 | C704 | 5345-S06BM107 | CAP, MINI ELE 100 μ /10V |
| 585 | C112 | 5345-474F0962 | CAP, MINI ELE .47 μ /50V | 743 | C705 | 5345-S06DM227 | CAP, MINI ELE 220 μ /25V |
| 590 | C113 | 5345-226D0962 | CAP, MINI ELE 22 μ /25V | 744 | C706 | 5345-S06FM106 | CAP, MINI ELE 10 μ /50V |
| 574 | C114 | 5369-823144 | CAP, SCD .082 μ | 747 | C707 | 5353-050534 | CAP, MCA 5p |
| 581 | C115 | 5361-681KSL | CAP, CER 680p | 747 | C708 | 5353-050534 | CAP, MCA 5p |
| 576 | C116 | 5354-274593 | CAP, MYL .27 μ | 746 | C709 | 5345-S06BM107 | CAP, MINI ELE 100 μ /10V |
| 584 | C117 | 5342-105F0951 | CAP, ELE BP 1 μ /50V | 744 | C710 | 5345-S06FM106 | CAP, MINI ELE 10 μ /50V |
| 575 | C118 | 5369-104144 | CAP, SCD .1 μ | 824 | C910 | 5345-226C0962 | CAP, MINI ELE 22 μ /16V |
| 579 | C119 | 5361-472KB | CAP, CER 4700p | RESISTORS | | | |
| 571 | C121 | 5369-103144 | CAP, SCD .01 μ | 525 | R2 | 5134-151J25P | RES, CBN 1/4P 150 |
| 586 | C122 | 5354-684593 | CAP, MYL .68 μ | 528 | R5 | 5232-471J16P | RES, CBN 1/6P 470 |
| 583 | C123 | 5361-392KB | CAP, CER 3900p | 528 | R6 | 5232-471J16P | RES, CBN 1/6P 470 |
| 580 | C124 | 5361-151KSL | CAP, CER 150p | 530 | R7 | 5232-102J16P | RES, CBN 1/6P 1K |
| 587 | C125 | 5345-106F0962 | CAP, MINI ELE 10 μ /50V | 530 | R8 | 5232-102J16P | RES, CBN 1/6P 1K |
| 585 | C126 | 5345-474F0962 | CAP, MINI ELE .47 μ /50V | 523 | R9 | 5134-101J25P | RES, CBN 1/4P 100 |
| 573 | C127 | 5369-563144 | CAP, SCD .056 μ | 527 | R10 | 5232-101J16P | RES, CBN 1/6P 100 |
| 588 | C128 | 5345-476B0962 | CAP, MINI ELE 47 μ /10V | 521 | R11 | 5135-1R0522 | RES, CBN 1/2P 1 |
| 588 | C129 | 5345-476B0962 | CAP, MINI ELE 47 μ /10V | 521 | R12 | 5135-1R0522 | RES, CBN 1/2P 1 |
| 537 | C130 | 5369-104144 | CAP, SCD .1 μ | 524 | R13 | 5134-220J25P | RES, CBN 1/4P 22 |
| 537 | C131 | 5369-104144 | CAP, SCD .1 μ | 529 | R29 | 5232-273J16P | RES, CBN 1/6P 27K |
| 537 | C132 | 5369-104144 | CAP, SCD .1 μ | 793 | R51 | 5134-821J25P | RES, CBN 1/4P 820 |
| 536 | C133 | 5345-107D0962 | CAP, MINI ELE 100 μ /25V | 798 | R52 | 5232-824J16P | RES, CBN 1/6P 820K |
| 536 | C134 | 5345-107D0962 | CAP, MINI ELE 100 μ /25V | 797 | R53 | 5232-473J16P | RES, CBN 1/6P 47K |
| 665 | C201 | 5361-332KB | CAP, CER 3300p | 789 | R54 | 5135-471522 | RES, CBN 1/2P 470 |
| 664 | C202 | 5361-562KB | CAP, CER 5600p | 792 | R55 | 5232-101J16P | RES, CBN 1/6P 100 |
| 663 | C203 | 5361-471KSL | CAP, CER 470p | 788 | R56 | 5134-154J25P | RES, CBN 1/4P 150K |
| 661 | C204 | 5354-154593 | CAP, MYL .15 μ | 795 | R59 | 5232-102J16P | RES, CBN 1/6P 1K |
| 660 | C206 | 5345-S06BM476 | CAP, MINI ELE 47 μ /10V | 794 | R60 | 5232-471J16P | RES, CBN 1/6P 470 |
| 538 | C209 | 5361-471KSL | CAP, CER 470p | 796 | R61 | 5232-103J16P | RES, CBN 1/6P 10K |
| 538 | C210 | 5361-471KSL | CAP, CER 470p | 787 | R62 | 5134-4R7J25P | RES, CBN 1/4P 4.7 |
| 537 | C211 | 5369-104144 | CAP, SCD .1 μ | 604 | R101 | 5134-220J25P | RES, CBN 1/4P 22 |
| 539 | C212 | 5361-220KSL | CAP, CER 22p | 611 | R102 | 5232-222J16P | RES, CBN 1/6P 2.2K |
| 537 | C213 | 5369-104144 | CAP, SCD .1 μ | 619 | R103 | 5232-163J16P | RES, CBN 1/6P 16K |
| 536 | C214 | 5345-107D0962 | CAP, MINI ELE 100 μ /25V | 616 | R104 | 5232-822J16P | RES, CBN 1/6P 8.2K |
| 536 | C215 | 5345-107D0962 | CAP, MINI ELE 100 μ /25V | 621 | R105 | 5232-223J16P | RES, CBN 1/6P 22K |
| 667 | C220 | 5361-223ZF | CAP, CER .022 μ | 605 | R106 | 5134-102J25P | RES, CBN 1/4P 1K |
| 666 | C225 | 5345-S06CM106 | CAP, MINI ELE 10 μ /16V | 601 | R107 | 5134-910J25P | RES, CBN 1/4P 91 |
| 690 | C301 | 5345-S06DM227 | CAP, MINI ELE 220 μ /25V | 620 | R108 | 5232-183J16P | RES, CBN 1/6P 18K |
| 690 | C302 | 5345-S06DM227 | CAP, MINI ELE 220 μ /25V | 618 | R109 | 5232-153J16P | RES, CBN 1/6P 15K |
| 690 | C303 | 5345-S06DM227 | CAP, MINI ELE 220 μ /25V | 605 | R110 | 5134-102J25P | RES, CBN 1/4P 1K |
| | | | | 606 | R111 | 5134-103J25P | RES, CBN 1/4P 10K |
| | | | | 627 | R112 | 5232-104J16P | RES, CBN 1/6P 100K |
| | | | | 617 | R113 | 5232-103J16P | RES, CBN 1/6P 10K |

| Ser.No | Ref. No. | Part No. | Description | Ser.No | Ref. No. | Part No. | Description |
|--------|----------|---------------|----------------------|--------|----------|--------------|--------------------|
| 621 | R114 | 5232-223J16P | RES, CBN 1/6P 22K | 721 | R310 | 5134-184J25P | RES, CBN 1/4P 180K |
| 626 | R115 | 5232-683J16P | RES, CBN 1/6P 68K | 717 | R311 | 5134-683J25P | RES, CBN 1/4P 68K |
| 618 | R116 | 5232-153J16P | RES, CBN 1/6P 15K | 717 | R312 | 5134-683J25P | RES, CBN 1/4P 68K |
| 615 | R117 | 5232-682J16P | RES, CBN 1/6P 6.8K | 710 | R313 | 5134-102J25P | RES, CBN 1/4P 1K |
| 610 | R118 | 5232-221J16P | RES, CBN 1/6P 220 | 710 | R314 | 5134-102J25P | RES, CBN 1/4P 1K |
| 625 | R119 | 5232-473J16P | RES, CBN 1/6P 47K | 708 | R315 | 5134-561J25P | RES, CBN 1/4P 560 |
| 606 | R120 | 5134-103J25P | RES, CBN 1/4P 10K | 708 | R316 | 5134-561J25P | RES, CBN 1/4P 560 |
| 606 | R121 | 5134-103J25P | RES, CBN 1/4P 10K | 714 | R317 | 5134-682J25P | RES, CBN 1/4P 6.8K |
| 622 | R122 | 5232-273J16P | RES, CBN 1/6P 27K | 714 | R318 | 5134-682J25P | RES, CBN 1/4P 6.8K |
| 606 | R124 | 5134-103J25P | RES, CBN 1/4P 10K | 704 | R319 | 5134-2R2J25P | RES, CBN 1/4P 2.2 |
| 551 | R125 | 5232-102J16P | RES, CBN 1/6P 1K | 704 | R320 | 5134-2R2J25P | RES, CBN 1/4P 2.2 |
| 627 | R126 | 5232-104J16P | RES, CBN 1/6P 100K | 709 | R321 | 5134-331J25P | RES, CBN 1/4P 330 |
| 627 | R127 | 5232-104J16P | RES, CBN 1/6P 100K | 709 | R322 | 5134-331J25P | RES, CBN 1/4P 330 |
| 625 | R128 | 5232-473J16P | RES, CBN 1/6P 47K | 724 | R323 | 5232-822J16P | RES, CBN 1/6P 8.2K |
| 617 | R129 | 5232-103J16P | RES, CBN 1/6P 10K | 724 | R324 | 5232-822J16P | RES, CBN 1/6P 8.2K |
| 616 | R130 | 5232-822J16P | RES, CBN 1/6P 8.2K | 710 | R325 | 5134-102J25P | RES, CBN 1/4P 1K |
| 627 | R131 | 5232-104J16P | RES, CBN 1/6P 100K | 710 | R326 | 5134-102J25P | RES, CBN 1/4P 1K |
| 627 | R132 | 5232-104J16P | RES, CBN 1/6P 100K | 707 | R327 | 5134-471J25P | RES, CBN 1/4P 470 |
| 614 | R133 | 5232-562J16P | RES, CBN 1/6P 5.6K | 707 | R328 | 5134-471J25P | RES, CBN 1/4P 470 |
| 612 | R134 | 5232-332J16P | RES, CBN 1/6P 3.3K | 704 | R329 | 5134-2R2J25P | RES, CBN 1/4P 2.2 |
| 620 | R135 | 5232-183J16P | RES, CBN 1/6P 18K | 704 | R330 | 5134-2R2J25P | RES, CBN 1/4P 2.2 |
| 621 | R136 | 5232-223J16P | RES, CBN 1/6P 22K | 708 | R331 | 5134-561J25P | RES, CBN 1/4P 560 |
| 624 | R137 | 5232-393J16P | RES, CBN 1/6P 39K | 708 | R332 | 5134-561J25P | RES, CBN 1/4P 560 |
| 621 | R138 | 5232-223J16P | RES, CBN 1/6P 22K | 710 | R333 | 5134-102J25P | RES, CBN 1/4P 1K |
| 613 | R139 | 5232-472J16P | RES, CBN 1/6P 4.7K | 710 | R334 | 5134-102J25P | RES, CBN 1/4P 1K |
| 624 | R140 | 5232-393J16P | RES, CBN 1/6P 39K | 710 | R335 | 5134-102J25P | RES, CBN 1/4P 1K |
| 550 | R141 | 5232-100J16P | RES, CBN 1/6P 10 | 710 | R336 | 5134-102J25P | RES, CBN 1/4P 1K |
| 550 | R142 | 5232-100J16P | RES, CBN 1/6P 10 | 706 | R337 | 5134-101J25P | RES, CBN 1/4P 100 |
| 550 | R143 | 5232-100J16P | RES, CBN 1/6P 10 | 706 | R338 | 5134-101J25P | RES, CBN 1/4P 100 |
| 613 | R144 | 5232-472J16P | RES, CBN 1/6P 4.7K | 708 | R339 | 5134-561J25P | RES, CBN 1/4P 560 |
| 603 | R150 | 5134-4R7J25P | RES, CBN 1/4P 4.7 | 708 | R340 | 5134-561J25P | RES, CBN 1/4P 560 |
| 603 | R151 | 5134-4R7J25P | RES, CBN 1/4P 4.7 | 706 | R341 | 5134-101J25P | RES, CBN 1/4P 100 |
| 554 | △ R154 | 5102-4R75116 | RES, FUSE 4.7 | 706 | R342 | 5134-101J25P | RES, CBN 1/4P 100 |
| 554 | △ R155 | 5102-4R75116 | RES, FUSE 4.7 | 713 | R343 | 5134-222J25P | RES, CBN 1/4P 2.2K |
| 679 | R201 | 5232-223J16P | RES, CBN 1/6P 22K | 713 | R344 | 5134-222J25P | RES, CBN 1/4P 2.2K |
| 678 | R202 | 5232-222J16P | RES, CBN 1/6P 2.2K | 720 | R345 | 5134-104J25P | RES, CBN 1/4P 100K |
| 674 | R203 | 5134-124J25P | RES, CBN 1/4P 120K | 720 | R346 | 5134-104J25P | RES, CBN 1/4P 100K |
| 673 | R204 | 5134-473J25P | RES, CBN 1/4P 47K | 718 | R347 | 5134-563J25P | RES, CBN 1/4P 56K |
| 680 | R205 | 5232-104J16P | RES, CBN 1/6P 100K | 718 | R348 | 5134-563J25P | RES, CBN 1/4P 56K |
| 549 | R207 | 5134-223J25P | RES, CBN 1/4P 22K | 711 | R349 | 5134-182J25P | RES, CBN 1/4P 1.8K |
| 552 | R209 | 5232-104J16P | RES, CBN 1/6P 100K | 711 | R350 | 5134-182J25P | RES, CBN 1/4P 1.8K |
| 552 | R210 | 5232-104J16P | RES, CBN 1/6P 100K | 703 | R351 | 5134-470J25P | RES, CBN 1/4P 47 |
| 553 | R211 | 5232-334J16P | RES, CBN 1/6P 330K | 703 | R352 | 5134-470J25P | RES, CBN 1/4P 47 |
| 553 | R212 | 5232-334J16P | RES, CBN 1/6P 330K | 705 | R353 | 5134-4R7J25P | RES, CBN 1/4P 4.7 |
| 550 | R213 | 5232-100J16P | RES, CBN 1/6P 10 | 705 | R354 | 5134-4R7J25P | RES, CBN 1/4P 4.7 |
| 552 | R214 | 5232-104J16P | RES, CBN 1/6P 100K | 705 | R355 | 5134-4R7J25P | RES, CBN 1/4P 4.7 |
| 552 | R215 | 5232-104J16P | RES, CBN 1/6P 100K | 705 | R356 | 5134-4R7J25P | RES, CBN 1/4P 4.7 |
| 552 | R216 | 5232-104J16P | RES, CBN 1/6P 100K | 704 | R357 | 5134-2R2J25P | RES, CBN 1/4P 2.2 |
| 552 | R217 | 5232-104J16P | RES, CBN 1/6P 100K | 704 | R358 | 5134-2R2J25P | RES, CBN 1/4P 2.2 |
| 550 | R218 | 5232-100J16P | RES, CBN 1/6P 10 | 704 | R359 | 5134-2R2J25P | RES, CBN 1/4P 2.2 |
| 671 | R219 | 5134-471J25P | RES, CBN 1/4P 470 | 704 | R360 | 5134-2R2J25P | RES, CBN 1/4P 2.2 |
| 554 | △ R220 | 5102-4R75116 | RES, FUSE 4.7 | 719 | R601 | 5134-103J25P | RES, CBN 1/4P 10K |
| 554 | △ R221 | 5102-4R75116 | RES, FUSE 4.7 | 719 | R602 | 5134-103J25P | RES, CBN 1/4P 10K |
| 628 | R223 | 5232-824J16P | RES, CBN 1/6P 820K | 719 | R603 | 5134-103J25P | RES, CBN 1/4P 10K |
| 602 | R224 | 5134-222J25P | RES, CBN 1/4P 2.2K | 719 | R604 | 5134-103J25P | RES, CBN 1/4P 10K |
| 602 | R225 | 5134-222J25P | RES, CBN 1/4P 2.2K | 719 | R605 | 5134-103J25P | RES, CBN 1/4P 10K |
| 602 | R226 | 5134-222J25P | RES, CBN 1/4P 2.2K | 719 | R606 | 5134-103J25P | RES, CBN 1/4P 10K |
| 672 | R227 | 5134-222J25P | RES, CBN 1/4P 2.2K | 719 | R607 | 5134-103J25P | RES, CBN 1/4P 10K |
| 672 | R228 | 5134-222J25P | RES, CBN 1/4P 2.2K | 719 | R608 | 5134-103J25P | RES, CBN 1/4P 10K |
| 672 | R229 | 5134-222J25P | RES, CBN 1/4P 2.2K | 716 | R609 | 5134-123J25P | RES, CBN 1/4P 12K |
| 675 | R230 | 5134-4R7J25P | RES, CBN 1/4P 4.7 | 716 | R610 | 5134-123J25P | RES, CBN 1/4P 12K |
| 548 | R250 | 5212-103J0701 | R COMPOSITE 10K (x7) | 723 | R611 | 5232-105J16P | RES, CBN 1/6P 1M |
| 547 | R251 | 5212-103J0401 | R COMPOSITE 10K (x4) | 723 | R612 | 5232-105J16P | RES, CBN 1/6P 1M |
| 710 | R301 | 5134-102J25P | RES, CBN 1/4P 1K | 722 | R615 | 5134-105J25P | RES, CBN 1/4P 1K |
| 710 | R302 | 5134-102J25P | RES, CBN 1/4P 1K | 761 | R701 | 5232-472J16P | RES, CBN 1/6P 4.7K |
| 713 | R303 | 5134-222J25P | RES, CBN 1/4P 2.2K | 756 | R702 | 5134-471J25P | RES, CBN 1/4P 470 |
| 713 | R304 | 5134-222J25P | RES, CBN 1/4P 2.2K | 757 | R703 | 5134-4R7J25P | RES, CBN 1/4P 4.7 |
| 717 | R305 | 5134-683J25P | RES, CBN 1/4P 68K | 755 | R704 | 5134-101J25P | RES, CBN 1/4P 100 |
| 717 | R306 | 5134-683J25P | RES, CBN 1/4P 68K | 822 | R910 | 5232-473J16P | RES, CBN 1/6P 47K |
| 720 | R307 | 5134-104J25P | RES, CBN 1/4P 100K | 821 | R911 | 5134-470J25P | RES, CBN 1/4P 47 |
| 720 | R308 | 5134-104J25P | RES, CBN 1/4P 100K | 820 | R912 | 5134-271J25P | RES, CBN 1/4P 270 |
| 721 | R309 | 5134-184J25P | RES, CBN 1/4P 180K | 823 | R913 | 5232-392J16P | RES, CBN 1/6P 3.9K |

| Ser.No | Ref. No. | Part No. | Description |
|----------------------------|----------|---------------|-------------|
| INTEGRATED CIRCUITS | | | |
| 561 | IC101 | 5653-CXA1081S | IC, LINEAR |
| 562 | IC102 | 5654-M51564P | IC, DIGITAL |
| 531 | IC103 | 5653-LA6520 | IC, LINEAR |
| 651 | IC201 | 5654-M50423FP | IC, DIGITAL |
| 652 | IC202 | 5654-M5M4416P | IC, DIGITAL |
| 532 | IC203 | 5653-LA6515 | IC, LINEAR |
| 741 | IC701 | 5654-MN6471M | IC, DIGITAL |

| TRANSISTORS | | | |
|--------------------|------|---------------|---------------|
| 501 | Q1 | 5614-2012 | XISTOR, NPN A |
| 502 | Q2 | 5612-1375 | XISTOR, PNP A |
| 504 | Q3 | 5611-999(F) | XISTOR, PNP R |
| 503 | Q4 | 5613-2320(F) | XISTOR, NPN R |
| 504 | Q5 | 5611-999(F) | XISTOR, PNP R |
| 503 | Q6 | 5613-2320(F) | XISTOR, NPN R |
| 505 | Q7 | 5616-SK246GR2 | FET, N-CH |
| 505 | Q8 | 5616-SK246GR2 | FET, N-CH |
| 771 | Q51 | 5611-999(F) | XISTOR, PNP R |
| 773 | Q54 | 5613-2320(F) | XISTOR, NPN R |
| 772 | Q55 | 5611-RN2202 | XISTOR, PNP R |
| 566 | Q101 | 5612-647(C) | XISTOR, PNP A |
| 567 | Q103 | 5613-2320(F) | XISTOR, NPN R |
| 567 | Q104 | 5613-2320(F) | XISTOR, NPN R |
| 656 | Q201 | 5613-2320(F) | XISTOR, NPN R |
| 681 | Q301 | 5613-2320L(F) | XISTOR, NPN R |
| 681 | Q302 | 5613-2320L(F) | XISTOR, NPN R |
| 682 | Q303 | 5611-999L(F) | XISTOR, PNP R |
| 682 | Q304 | 5611-999L(F) | XISTOR, PNP R |
| 681 | Q305 | 5613-2320L(F) | XISTOR, NPN R |
| 681 | Q306 | 5613-2320L(F) | XISTOR, NPN R |
| 682 | Q307 | 5611-999L(F) | XISTOR, PNP R |
| 682 | Q308 | 5611-999L(F) | XISTOR, PNP R |
| 682 | Q309 | 5611-999L(F) | XISTOR, PNP R |
| 682 | Q310 | 5611-999L(F) | XISTOR, PNP R |
| 681 | Q311 | 5613-2320L(F) | XISTOR, NPN R |
| 681 | Q312 | 5613-2320L(F) | XISTOR, NPN R |
| 682 | Q313 | 5611-999L(F) | XISTOR, PNP R |
| 682 | Q314 | 5611-999L(F) | XISTOR, PNP R |
| 681 | Q315 | 5613-2320L(F) | XISTOR, NPN R |
| 681 | Q316 | 5613-2320L(F) | XISTOR, NPN R |
| 685 | Q317 | 5616-SK246GR2 | FET, N-CH |
| 685 | Q318 | 5616-SK246GR2 | FET, N-CH |
| 684 | Q319 | 5613-2878(B) | XISTOR, NPN R |
| 684 | Q320 | 5613-2878(B) | XISTOR, NPN R |
| 684 | Q321 | 5613-2878(B) | XISTOR, NPN R |
| 684 | Q322 | 5613-2878(B) | XISTOR, NPN R |
| 685 | Q601 | 5616-SK246GR2 | FET, N-CH |
| 685 | Q602 | 5616-SK246GR2 | FET, N-CH |
| 683 | Q603 | 5611-RN2202 | XISTOR, PNP R |
| 812 | Q910 | 5611-RN2201 | XISTOR, PNP R |

| DIODES | | | |
|---------------|-------|--------------|--------------|
| 515 | △ D1 | 5632-GP10E | DIODE, RECT |
| 515 | △ D2 | 5632-GP10E | DIODE, RECT |
| 515 | △ D3 | 5632-GP10E | DIODE, RECT |
| 515 | △ D4 | 5632-GP10E | DIODE, RECT |
| 515 | △ D5 | 5632-GP10E | DIODE, RECT |
| 515 | △ D6 | 5632-GP10E | DIODE, RECT |
| 515 | △ D7 | 5632-GP10E | DIODE, RECT |
| 518 | D8 | 5635-HZ27-2 | DIODE, ZENER |
| 517 | D9 | 5635-HZ6C3L | DIODE, ZENER |
| 517 | D10 | 5635-HZ6C3L | DIODE, ZENER |
| 515 | △ D11 | 5632-GP10E | DIODE, RECT |
| 515 | △ D12 | 5632-GP10E | DIODE, RECT |
| 516 | D15 | 5635-HZ5B-2 | DIODE, ZENER |
| 782 | D53 | 5631-1SS133 | DIODE, DET |
| 784 | D54 | 5635-HZ6A1-L | DIODE, ZENER |
| 785 | D55 | 5635-HZ3B-2 | DIODE, ZENER |
| 782 | D56 | 5631-1SS133 | DIODE, DET |
| 783 | D57 | 5632-GP10E | DIODE, RECT |
| 592 | D103 | 5631-1SS133 | DIODE, DET |
| 543 | D104 | 5635-HZ3B-2 | DIODE, ZENER |

| Ser.No | Ref. No. | Part No. | Description |
|--------|----------|-------------|--------------|
| 543 | D105 | 5635-HZ3B-2 | DIODE, ZENER |
| 592 | D106 | 5631-1SS133 | DIODE, DET |
| 700 | D601 | 5631-1SS133 | DIODE, DET |
| 700 | D602 | 5631-1SS133 | DIODE, DET |

| CONTROLS | | | |
|-----------------|-------|---------------|-------------------|
| 599 | VR101 | 5101-22301934 | RES, SEMI FIX 22K |
| 600 | VR102 | 5101-50201934 | RES, SEMI FIX 5K |

| MISCELLANEOUS | | | |
|----------------------|--------|---------------|---------------|
| 831 | CN110 | 4443-0801140 | CONNECTOR |
| 836 | CN111 | 4443-0701140 | CONNECTOR |
| 835 | CN112 | 4443-0501140 | CONNECTOR |
| 835 | CN113 | 4443-0501140 | CONNECTOR |
| 833 | CN114 | 4443-03901008 | CONNECTOR |
| 831 | CN115 | 4443-0801140 | CONNECTOR |
| 835 | CN116 | 4443-0501140 | CONNECTOR |
| 834 | CN117 | 4443-0401140 | CONNECTOR |
| 837 | CN118 | 4443-060185 | CONNECTOR |
| 838 | CN120 | 4443-0301140 | CONNECTOR |
| 832 | CN122 | 4443-0201140 | CONNECTOR |
| 871 | GND1 | 4214-132 | TERMINAL |
| 840 | △ J301 | 4489-02501002 | PIN JACK, MLT |
| 830 | △ J901 | 4451-00184 | JACK, 1P |
| 830 | △ J902 | 4451-00184 | JACK, 1P |
| 809 | PH910 | 5624-ON3161 | PHOTO COUPLR |
| 727 | W701 | 4132-R0102181 | CORD, 2C |
| 728 | W702 | 4132-R0102221 | CORD, 2C |
| 751 | X701 | 5691-S0901343 | XTAL, OSC |

PCB-2 FRONT P.C. BOARD

| CAPACITORS | | | |
|-------------------|------|---------------|------------------------|
| 806 | C401 | 5345-S06FM106 | CAP, MINI ELE 10μ/50V |
| 808 | C402 | 5354-104593 | CAP, MYL .1μ |
| 806 | C403 | 5345-S06FM106 | CAP, MINI ELE 10μ/50V |
| 807 | C404 | 5345-S06BM107 | CAP, MINI ELE 100μ/10V |

| RESISTORS | | | |
|------------------|------|---------------|----------------------|
| 815 | R401 | 5212-103J0401 | R COMPOSITE 10K (x4) |
| 816 | R402 | 5134-102J25P | RES, CBN 1/4P 1K |
| 817 | R403 | 5134-101J25P | RES, CBN 1/4P 100 |

| INTEGRATED CIRCUITS | | | |
|----------------------------|-------|---------------|-------------|
| 801 | IC401 | 5654-M957-243 | IC, DIGITAL |

| DIODES | | | |
|---------------|------|-------------|------------|
| 814 | D401 | 5631-1S2473 | DIODE, DET |
| 814 | D402 | 5631-1S2473 | DIODE, DET |
| 814 | D403 | 5631-1S2473 | DIODE, DET |
| 814 | D404 | 5631-1S2473 | DIODE, DET |
| 814 | D405 | 5631-1S2473 | DIODE, DET |
| 814 | D406 | 5631-1S2473 | DIODE, DET |
| 814 | D407 | 5631-1S2473 | DIODE, DET |
| 814 | D408 | 5631-1S2473 | DIODE, DET |
| 814 | D409 | 5631-1S2473 | DIODE, DET |
| 814 | D410 | 5631-1S2473 | DIODE, DET |
| 814 | D411 | 5631-1S2473 | DIODE, DET |
| 814 | D412 | 5631-1S2473 | DIODE, DET |
| 813 | D413 | 5631-1SS133 | DIODE, DET |
| 814 | D414 | 5631-1S2473 | DIODE, DET |

| MISCELLANEOUS | | | |
|----------------------|--------|---------------|---------------|
| 802 | FL401 | 5722-046 | TUBE DISPLAY |
| 825 | LCN110 | 4163-S0108161 | CONNECTOR W/W |
| 826 | LCN111 | 4163-S0107161 | CONNECTOR W/W |
| 827 | LCN112 | 4163-S0105161 | CONNECTOR W/W |
| 828 | LCN116 | 4163-S0105301 | CONNECTOR W/W |
| 810 | LCN120 | 4163-S0103321 | CONNECTOR W/W |
| 829 | LCN122 | 4163-S0102301 | CONNECTOR W/W |
| 803 | RC401 | 6143-00802 | RECEIV BLOCK |
| 811 | SW401 | 4437-00610 | SWITCH, PU-TC |
| 811 | SW402 | 4437-00610 | SWITCH, PU-TC |

| Ser.No | Ref. No. | Part No. | Description |
|--------|----------|------------|---------------|
| 811 | SW403 | 4437-00610 | SWITCH, PU-TC |
| 811 | SW404 | 4437-00610 | SWITCH, PU-TC |
| 811 | SW405 | 4437-00610 | SWITCH, PU-TC |
| 811 | SW406 | 4437-00610 | SWITCH, PU-TC |
| 811 | SW407 | 4437-00610 | SWITCH, PU-TC |
| 811 | SW408 | 4437-00610 | SWITCH, PU-TC |
| 811 | SW409 | 4437-00610 | SWITCH, PU-TC |
| 811 | SW410 | 4437-00610 | SWITCH, PU-TC |
| 811 | SW411 | 4437-00610 | SWITCH, PU-TC |
| 811 | SW412 | 4437-00610 | SWITCH, PU-TC |
| 811 | SW413 | 4437-00610 | SWITCH, PU-TC |
| 811 | SW414 | 4437-00610 | SWITCH, PU-TC |

PCB-3 POWER SWITCH P.C. BOARD

CAPACITORS

| | | |
|------------------|---------------|----------------------------|
| 865 Δ C1 | 5352-S010M103 | CAP, MTL .01 μ BK |
| 865B Δ C1 | 5352-1030961 | CAP, MTL .01 μ I IB BB |
| 865B Δ C1 | 5352-1030961 | CAP, MTL .01 μ WB |

RESISTORS

| | | |
|------------------|--------------|--------------------------|
| 027B Δ R1 | 5135-335J50P | RES, CBN 1/2P 3.3M I |
| 027C Δ R1 | 5134-335J25P | RES, CBN 1/4P 3.3M IB BB |
| 027B Δ R1 | 5135-335522 | RES, CBN 1/2P 3.3M WB |

TRANSFORMERS

| | | |
|------------------|------------|---------------------------|
| 861 Δ T1 | 5584-S8801 | XFORMER, POWER BK |
| 861B Δ T1 | 5584-S8802 | XFORMER, POWER I IB BB WB |

MISCELLANEOUS

| | | |
|-------------------|---------------|--------------------------|
| 864 Δ SW1 | 4433-01301 | SWITCH, PU-PW BK |
| 026B Δ SW2 | 4411-1047111 | SWITCH, ROTRY I IB BB WB |
| 872 Δ TM1 | 4214-122 | TERMINAL |
| 872 Δ TM2 | 4214-122 | TERMINAL |
| 867 | 4242-R0406201 | JUMPER LEAD |

CHASSIS MISCELLANEOUS

MISCELLANEOUS

| | | |
|------------------|---------------|--------------------------------------|
| 887 Δ P1 | 4161-03601202 | CORD W/PLUG BK |
| 887B Δ P1 | 4161-03701220 | CORD W/PLUG I IB BB |
| 887B Δ P1 | 4161-7256 | CORD W/PLUG WB |
| 880 | 4191-0355 | BATTERY, DRY |
| 883 | 4163-03211008 | CONNECTOR W/W |
| 884 | 4163-03210008 | CONNECTOR W/W |
| 885 | 4163-03212005 | CONNECTOR W/W |
| 886 | 4163-03207004 | CONNECTOR W/W |
| 888 | 4161-71184 | CORD W/PLUG, RCA TYPE (ACCESSORY) |
| 882 | 4162-00201800 | LUG W/WIRE |

ABBREVIATIONS IN PARTS LIST

CAPACITORS

| | |
|---------------|------------------------|
| CAP, MINI ELE | : Electrolytic |
| CAP, CER | : Ceramic |
| CAP, PPP | : Polypropylene |
| CAP, MYL | : Mylar |
| CAP, MCA | : Mica |
| CAP, MINI BP | : Bipolar |
| CAP, ELE BP | : Electrolytic Bipolar |
| 470 μ | : 470 μ F |
| 6800p | : 6800pF |
| .047 μ | : 0.047 μ F |

RESISTORS

| | |
|---------------|-----------------|
| RES, CBN 1/6P | : Carbon 1/6W |
| RES, FUSE | : Fuse |
| RES, CEM 5P | : Cement 5W |
| RES, MTL 1P | : Metal 1W |
| 2.2K | : 2.2K Ω |
| 220 | : 220 Ω |

TRANSISTORS

| | |
|--------|---------------------------|
| XISTOR | : Transistor |
| FET | : Field Effect Transistor |

CONTROLS

| | |
|---------------|-----------------------|
| RES, SEMI FIX | : Semi-fixed Resistor |
|---------------|-----------------------|

NOTE



SAFETY RELATED COMPONENT. USE ONLY EXACT REPLACEMENT PART AS SPECIFIED.

PACKAGE

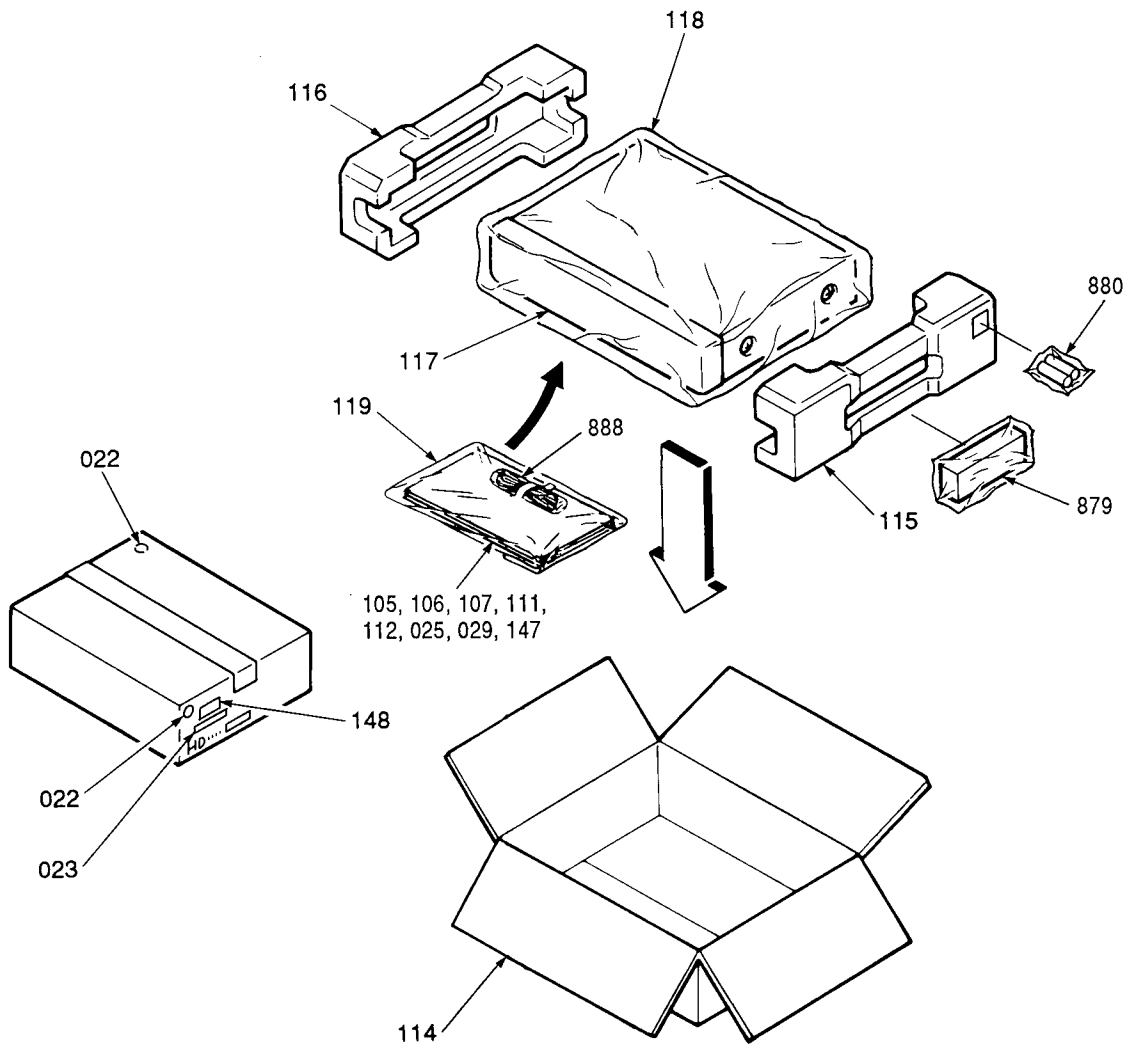

PARTS LIST (PACKAGE)

| Ref. No. | Part No. | Description | Ref. No. | Part No. | Description |
|----------|-------------|---------------------------------------|----------|---------------|----------------------------|
| 022 | 1756-03108 | LABEL I (x2) I IB BB | 112 | 1119-03402 | ATTACH SHEET BK |
| 022 | 1756-03101 | LABEL W (x2) WB | 114 | 1221-28110 | CARTON BOX I |
| 023 | 1756-06303 | LABEL VOLTAGE I IB BB WB | 114 | 1221-28111 | CARTON BOX BK IB BB |
| 025 | 1111-M30253 | OWNER GUIDE I IB | 114 | 1221-28119 | CARTON BOX WB |
| 025 | 1111-M30319 | OWNER GUIDE BB | 115 | 1222-7366 | CUSHION, R |
| 025 | 1111-J30253 | OWNER GUIDE WB | 116 | 1222-7367 | CUSHION, L |
| 029 | 1756-08501 | LABEL, 240V BB | 117 | 1223-11729 | SOFT SHEET, FRONT PANEL |
| 029 | 1111-J30320 | OWNER GUIDE, ADDENDUM SHEET WB | 118 | 1241-C1491 | POLYETHY BAG |
| 105 | 1111-M30331 | OWNER GUIDE BK | 119 | 1241-R0123350 | POLYETHY BAG |
| 105 | 1111-M30332 | OWNER GUIDE I IB | 148 | 1756-11701 | LABEL, DHHS CARD BK |
| 105 | 1111-J30331 | OWNER GUIDE WB | 879 | 6142-05505 | REMOTE CONTROL UNIT |
| 106 | 1119-01202 | ATTACH SHEET BK | 880 | 4191-0355 | BATTERY, DRY |
| 107 | 1113-717004 | OWNER CARD BK | 888 | 4191-71184 | CORD W/PLUG (ACCESSORY) |
| 111 | 1119-03102 | ATTACH SHEET BK | | | |

INFRARED REMOTE CONTROL SCHEMATIC DIAGRAM

1
2
3
4
5
6
7

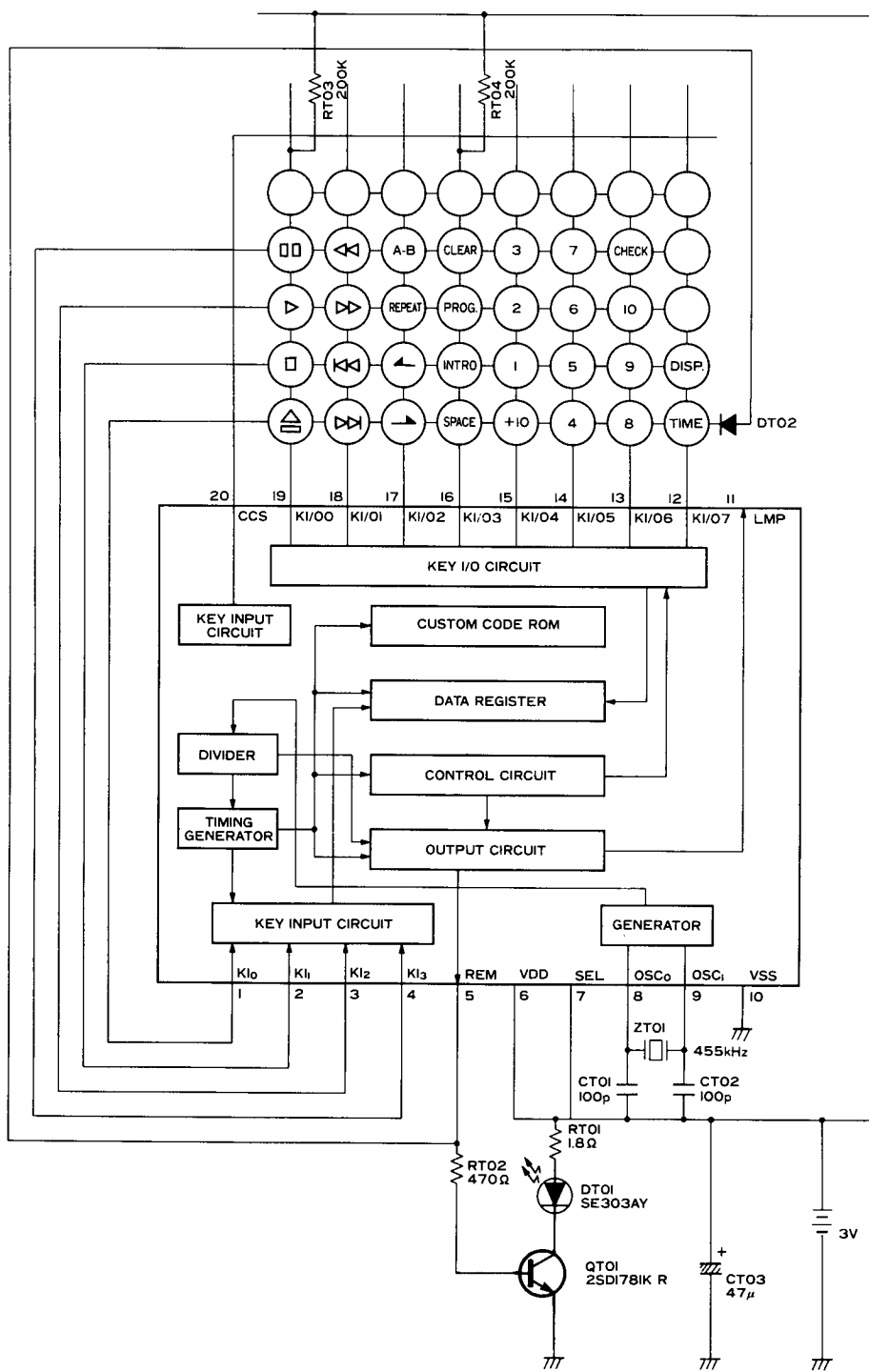

SCHEMATIC DIAGRAM

Page 51

Page 51

(C)

(D)

LCN120

LCN111

LCN112

Page 51

(A) (B) (C) (D) (E)

LCN122

Page 51

(A) (B) (C) (D) (E)

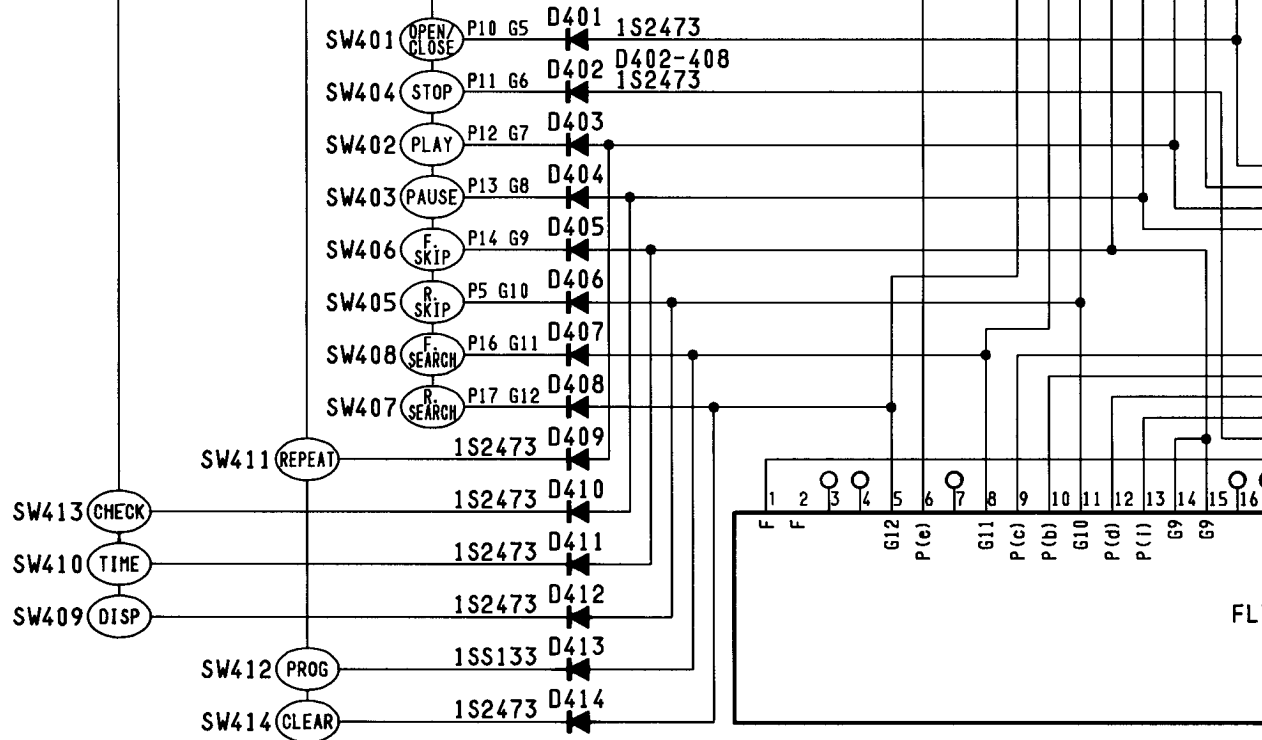
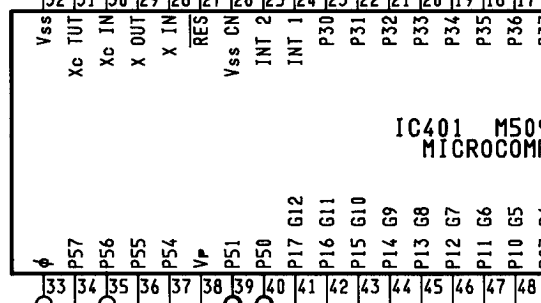
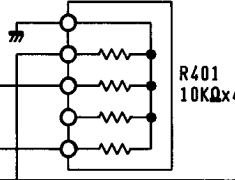

1

2

3

4

5

6

7



LCN110

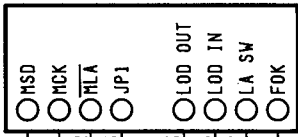

NOTE:

1. ALL RESISTANCES VALUES ARE IN Ω .
K Ω =1000 Ω , M Ω =1000K Ω .
2. THE WATTAGE OF RESISTORS IS 1/4W OR 1/2W UNLESS OTHERWISE NOTED.
3. ALL CAPACITANCES VALUES ARE IN μ F UNLESS OTHERWISE NOTED. P= μ F.
4. ...V:DC VOLTAGE AT NO SIGNAL UNLESS OTHERWISE NOTED.
5. SAFETY REQUIREMENTS COMPONENTS IN ACCORDANCE WITH PRESENT SAFETY REGULATIONS, THESE COMPONENTS MUST ONLY BE REPLACED BY ORIGINAL PARTS.

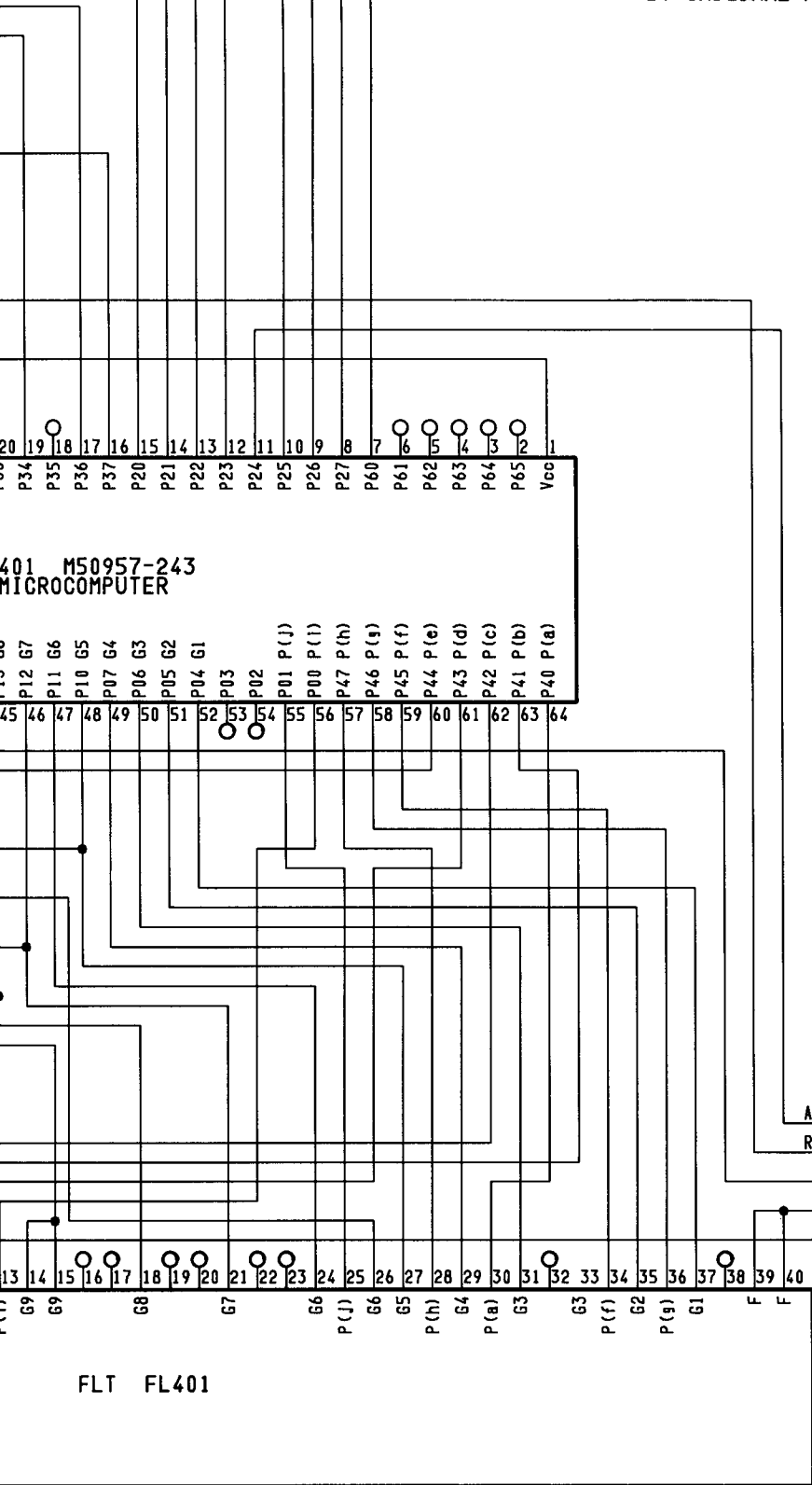

LCN116

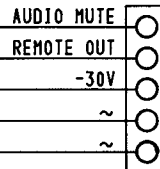

A B C D E F G

SCHEMATIC DIAGRAM

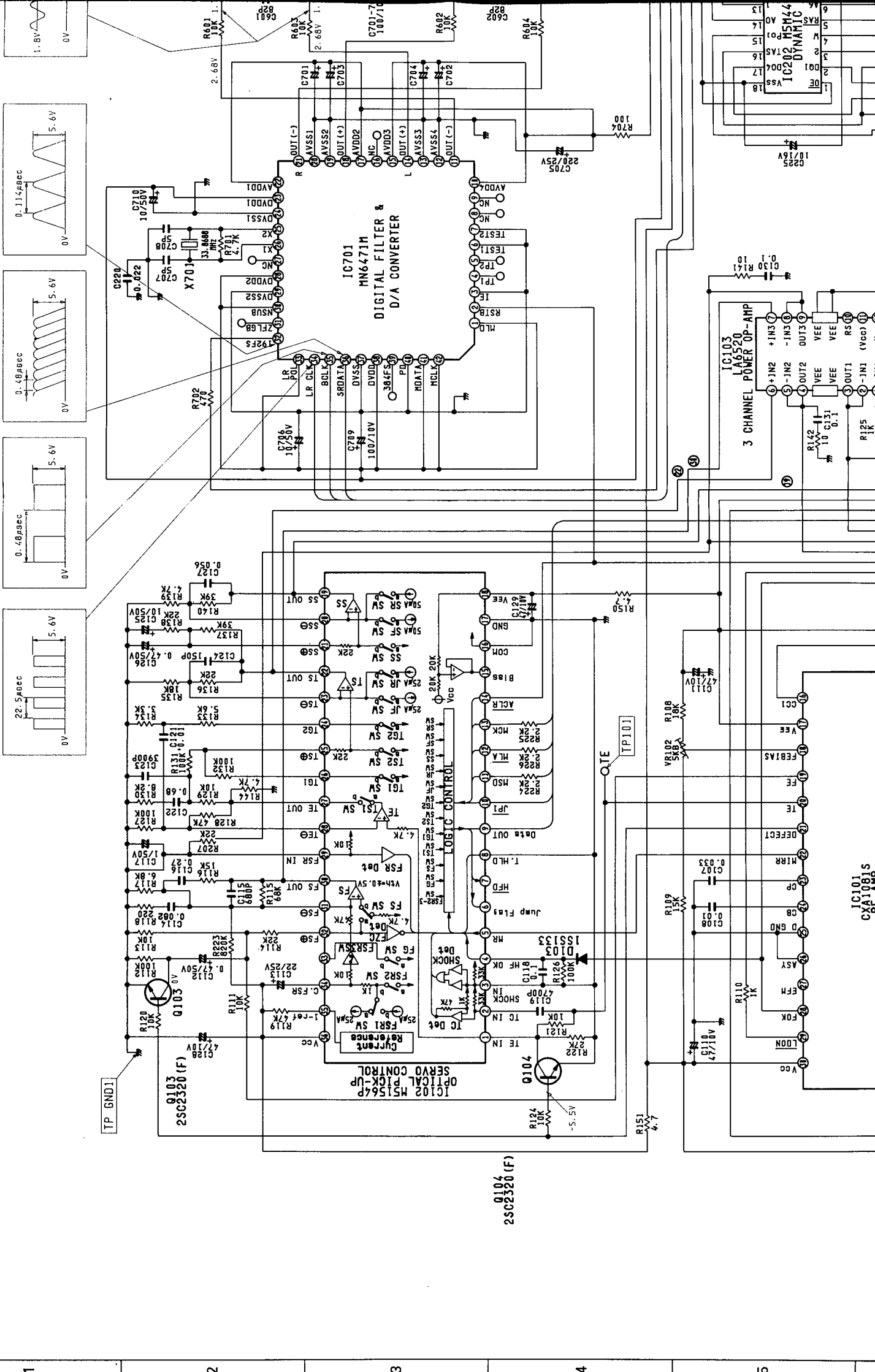

H I J K L M N

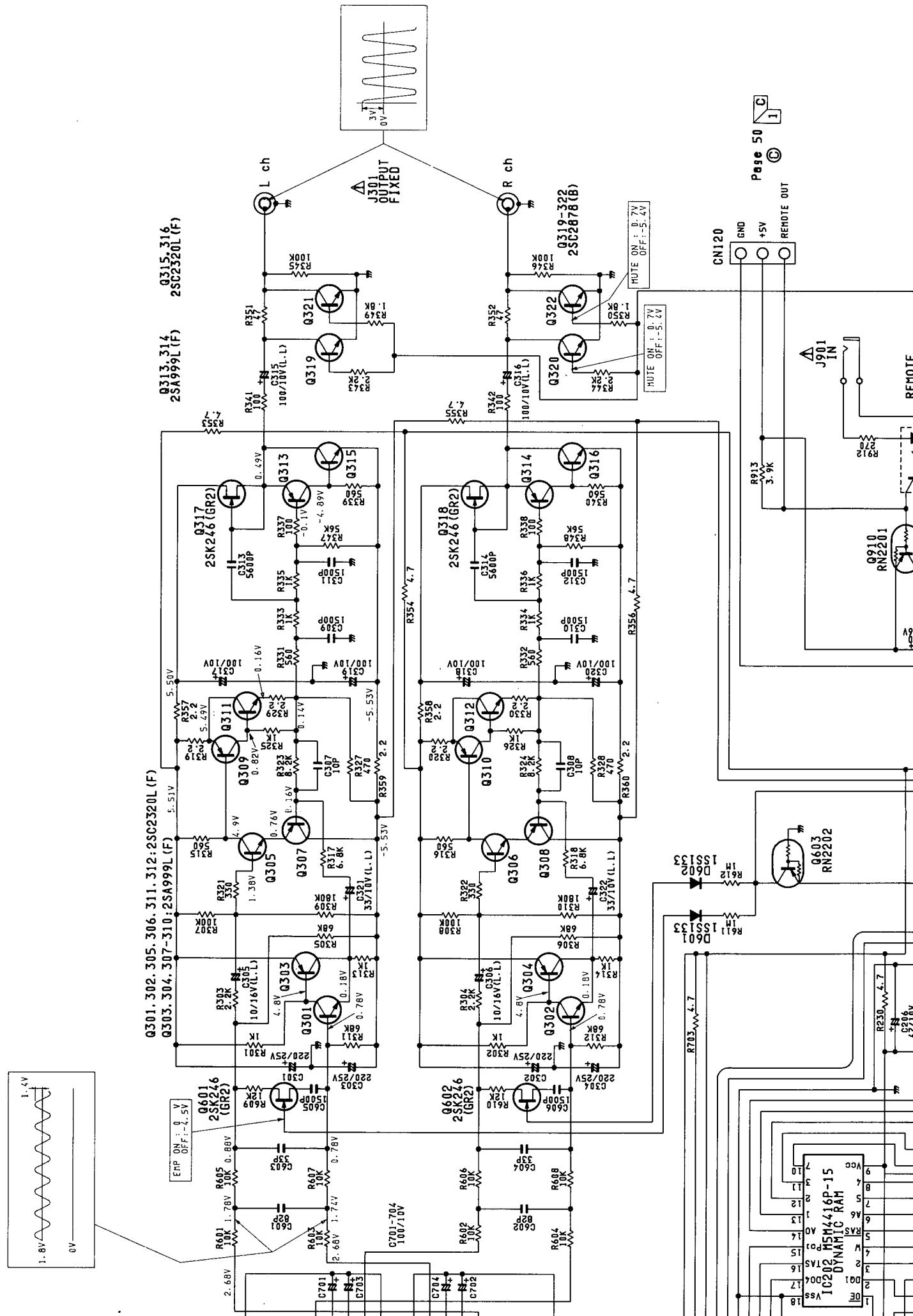

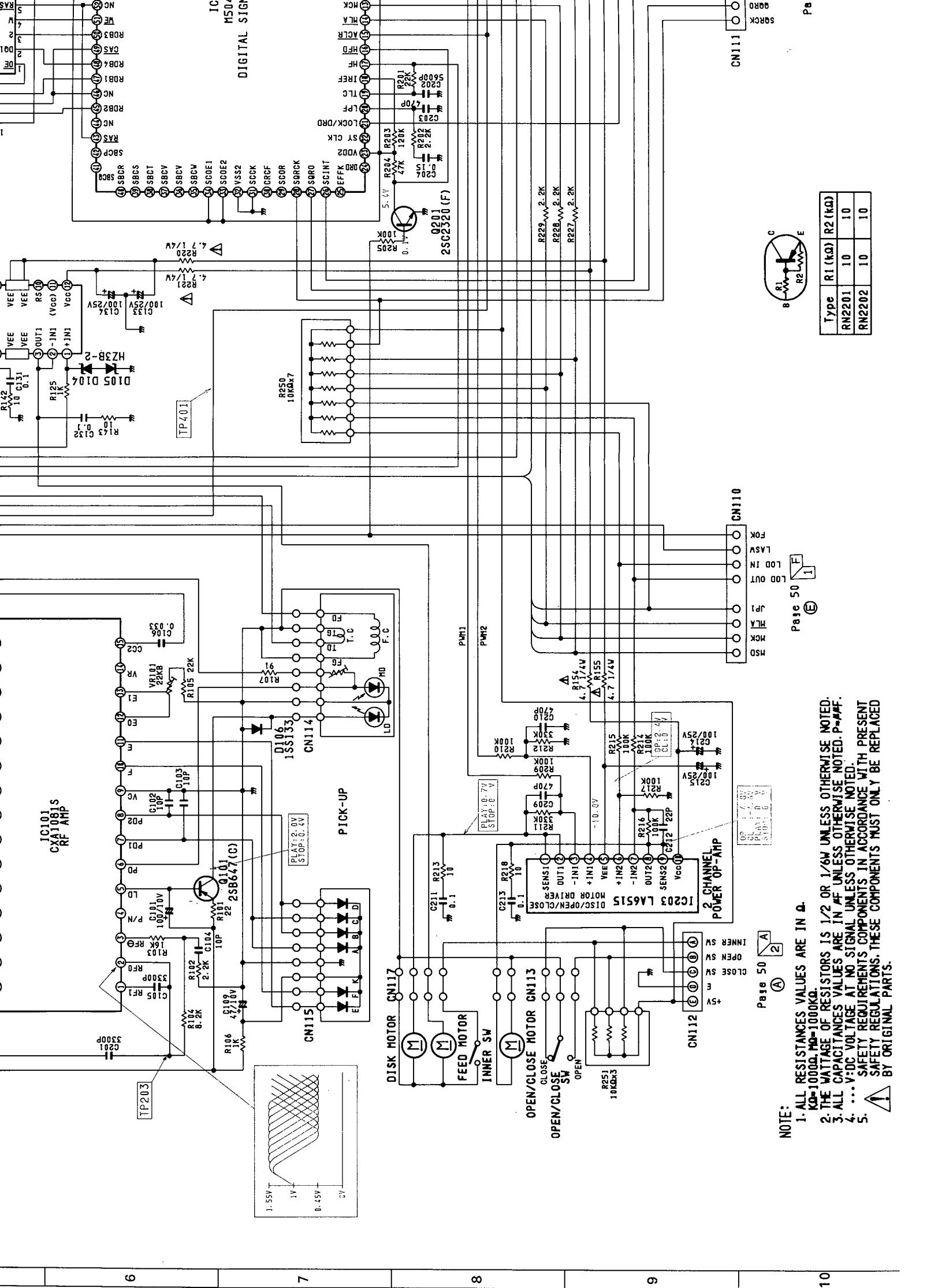

| Type | R1 (kΩ) | R2 (kΩ) |
|--------|---------|---------|
| RN2201 | 10 | 10 |
| RN2202 | 10 | 10 |

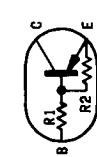

Page 50 (E)

Page 50 (A)

- NOTE:**
1. ALL RESISTANCE VALUES ARE IN Ω.
 2. THE WATTAGE OF RESISTORS IS 1/2 OR 1/6W UNLESS OTHERWISE NOTED.
 3. ALL CAPACITANCE VALUES ARE IN pF UNLESS OTHERWISE NOTED.
 4. ... V:DC VOLTAGE AT NO SIGNAL UNLESS OTHERWISE NOTED.
 5. SAFETY REQUIREMENTS COMPONENTS IN ACCORDANCE WITH PRESENT SAFETY REGULATIONS. THESE COMPONENTS MUST ONLY BE REPLACED BY ORIGINAL PARTS.

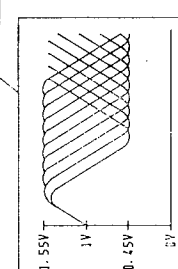

TP203

TP401

OP: 0.7V
CL: 0.1V
STOP: 0.0V

PLAY: 0.7V
STOP: 0.0V

PICK-UP

PLAY: 2.0V
STOP: 0.4V

Page 50 (A)

Page 50 (E)

Page 50 (E)

Page 50 (E)

Page 50 (E)

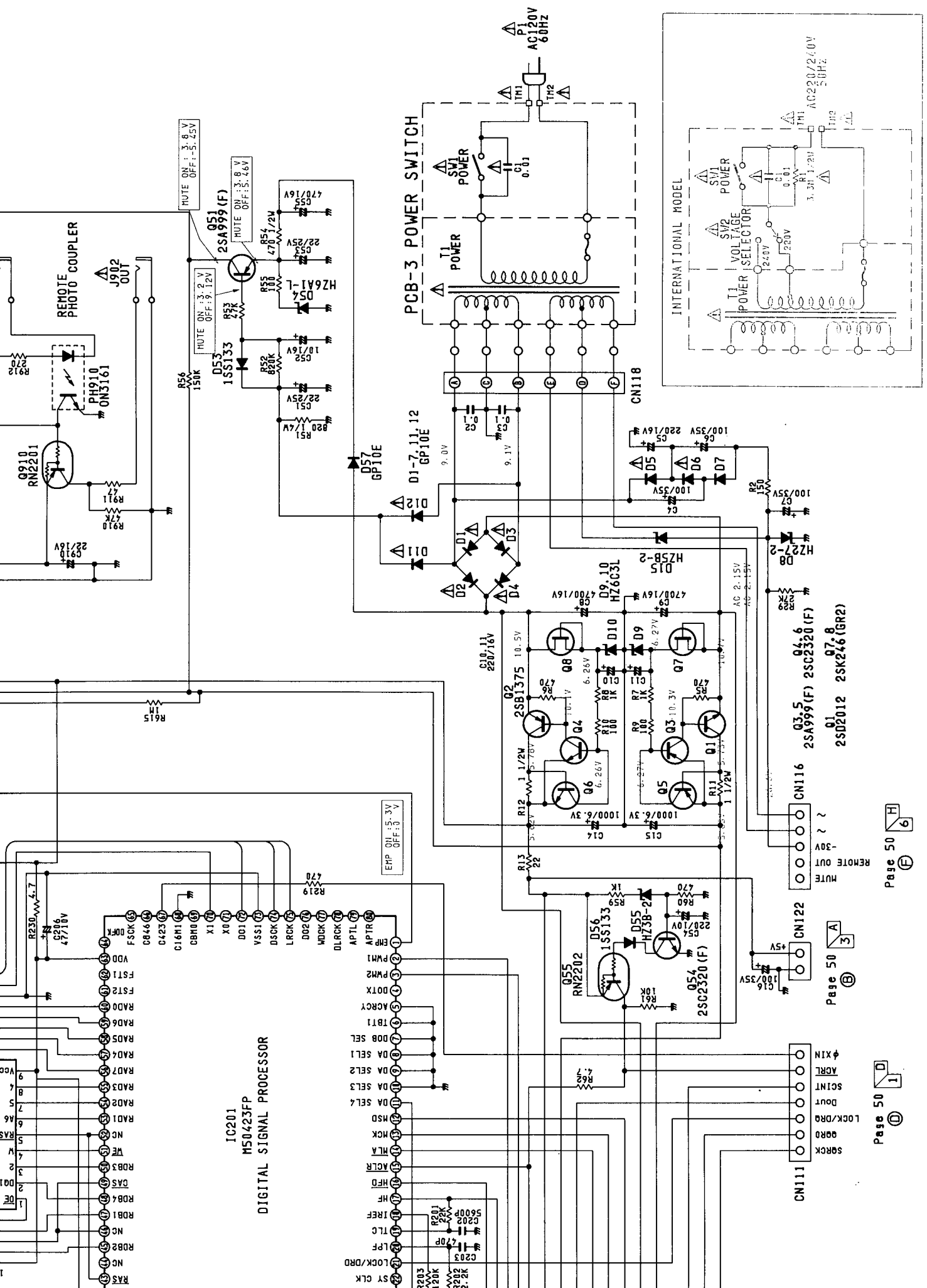

IC201
MS0423FP
DIGITAL SIGNAL PROCESSOR

A

B

C

D

E

WIRING DIAGRAM

1

2

3

4

5

6

7

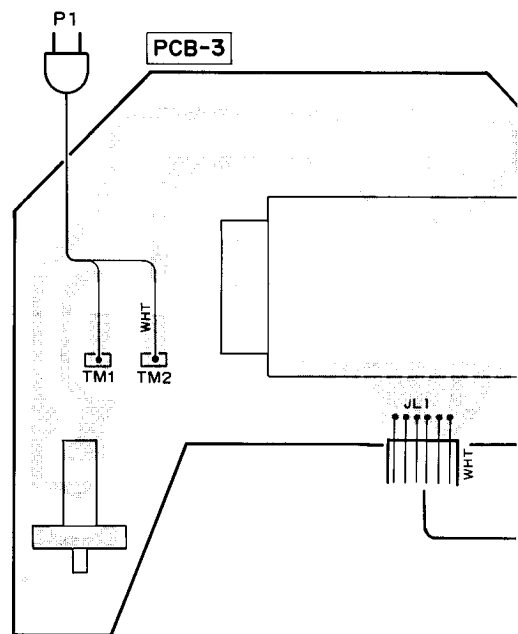
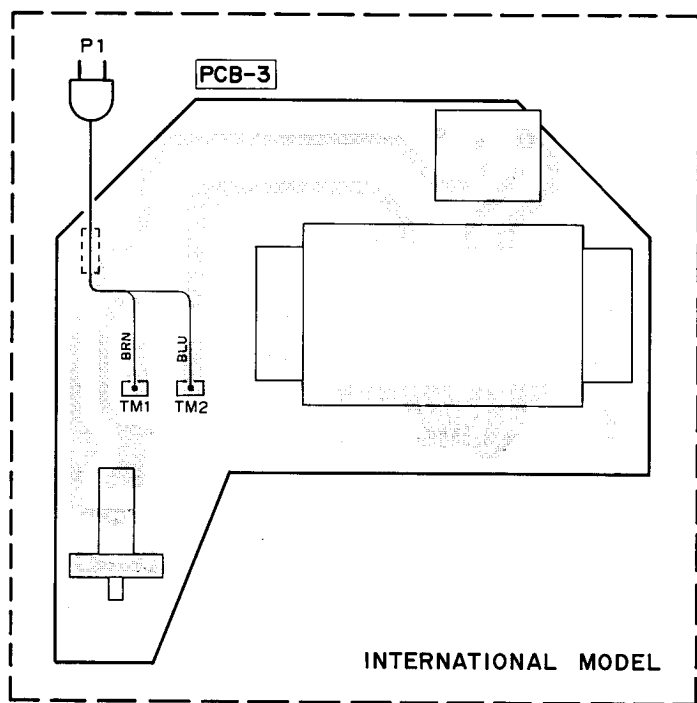

LCN115

LCN114

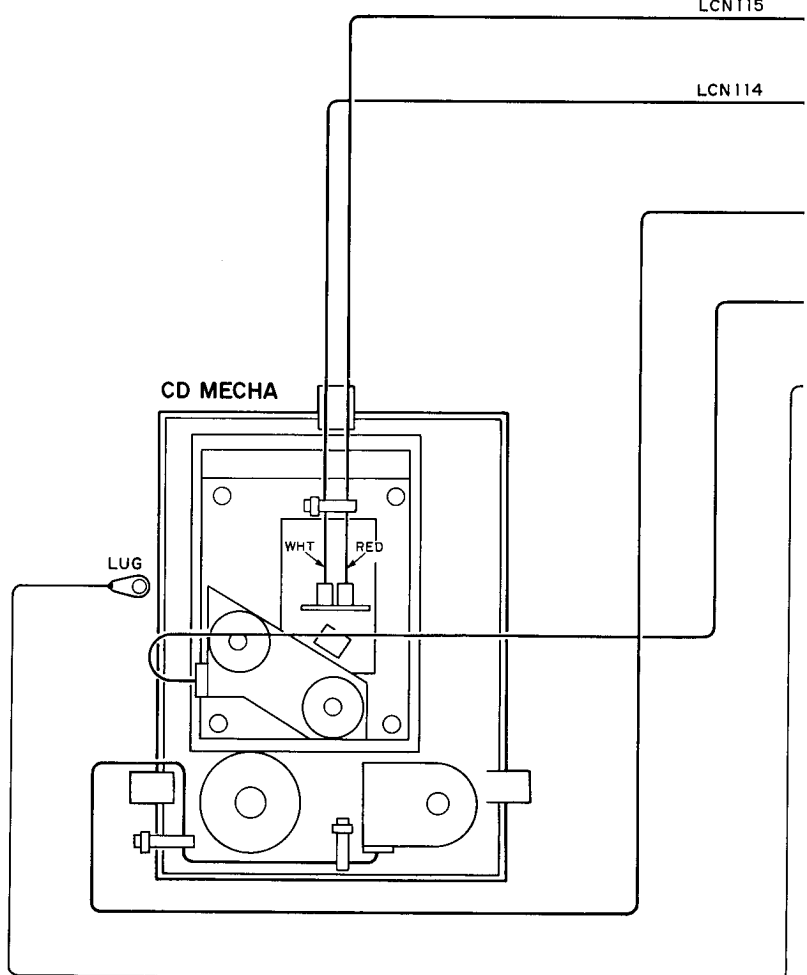

WIRE COLOR ABBREVIATIONS

- | | |
|--------------|--------------|
| RED : Red | YEL : Yellow |
| ORG : Orange | PUP : Purple |
| BLU : Blue | OIK : Pink |
| WHT : White | GRY : Gray |
| BLK : Black | BRN : Brown |

E F G H I J

