

The Citation Sixteen (series A)

Professional Stereophonic Power Amplifier

Technical Manual

WARNING

These technical instructions are for use by qualified service personnel only. To avoid electric shock, do not perform any servicing other than that contained in the operating instructions unless qualified to do so.

harman/kardon

CITATION SIXTEEN SPECIFICATIONS

| | |
|------------------------------------|--|
| Power Output: | 150 watts min. rms per channel, Both channels driven into 8 ohms from 20Hz to 20kHz, with less than 0.05% THD |
| Power Bandwidth: | From 5Hz to 45kHz at less than 0.05% THD into 8 ohms, both channels driven simultaneously at 75 watts per channel |
| Frequency Response: | From 4Hz to 120kHz, +0dB -3dB, both channels driven simultaneously at 1 watt per channel, into 8 ohms |
| Square Wave Rise Time: | Better than 3 microseconds |
| Slew Rate: | Greater than 30V/ μ sec |
| Total Harmonic Distortion: | Less than 0.05% from 1 watt to 150 watts RMS, both channels driven simultaneously into 8 ohms from 0.5Hz to 20kHz |
| Intermodulation Distortion: | Less than 0.05% at from 0.015 watts to 150 watts |
| Hum and Noise: | Better than 100dB below 150 watts |
| Damping Factor: | 300:1 |
| Input Impedance: | 22k ohms |
| Input Sensitivity: | 1.25 volts for 150 watts |
| Phase Shift: | Less than 0.5 degrees at 20Hz, less than 12 degrees at 20kHz |
| Inputs: | One RCA type input terminal per channel |
| Outputs: | Instrument type binding posts. Accepts speakers from 4 to 16 ohms |
| Dimensions: | 9 1/8" H x 19 1/8" W x 13 9/16" D (complete with metal cage) (23.2 cm H x 48.6 cm W x 34.4 cm D) |
| Weight: | 55 pounds (24.9Kg) |

PRECAUTIONS

1. Always disconnect the chassis from power line when soldering. Turning the power switch OFF is not enough. Power line leakage passing through the heating element may destroy the transistors.
2. Never attempt to do any work on the transistor amplifiers without first disconnecting the AC line cord and waiting until the power supply filter capacitors have discharged.
3. Replacement for output and driver transistors, if necessary, must be made from the same beta group as the original type.
4. If one output transistor burns out (open or short) always remove all the output transistors in that channel and check the bias adjustment, the control and other parts in the network with an ohmmeter before inserting a new transistor. All transistors in one channel will be destroyed if the base biasing circuit is open on the emitter end.
5. When mounting a replacement power transistor, be sure that the bottom of the flange, the mica insulators and the surface of the heat sink are free of foreign matter, for they may cause transistor failure.
6. Silicon grease must be applied between the transistor and the mica insulator, and between the mica insulator and the heat sink for better heat conduction.
7. Fuses must be replaced with size and type indicated. Use of other types can expose components to destructive current levels.

TECHNICAL DESCRIPTION

I. POWER SUPPLY

The Citation 16 is essentially two monophonic amplifiers on the same chassis, each channel driven by a separate power supply. This "twin-powered" configuration allows sufficient voltage reserves for exacting transient response and eliminates all possibilities of interaction between channels. Each supply delivers ± 60 volts DC to the driver and output stages of the Citation 16 and ± 12 volts DC to its LED display. Two 10,000 microfarad electrolytics per channel provide ample capacity for the output demands and filtering of ripple.

When the POWER switch on the front panel is depressed, the neon indicator lights should glow. If one of the lamps does not light, the corresponding fuse is blown and that channel is not receiving power. The channel fuses are 4 ampere slow blow types, located on the back panel. They protect the circuitry of the Citation 16, not the speaker systems.

A relay provides speaker protection by interrupting the output. A one-second delay on turn-on, and instant turn-off prevent transients from reaching the speakers. The relay also protects against low frequency oscillation and DC voltages at the output.

II. DRIVER BOARD

The driver board contains input network, current fold-back, and bias maintenance circuitry as well as the preamplification and drive stages.

A shaping network at the input (C1, C2, R1, R2) filters frequencies below 0.1Hz, thus performing the essential function of blocking inadvertent DC inputs, without significantly affecting response above 2Hz. It also rolls off frequencies above 390kHz at a slope of 6dB per octave.

THE PREAMPLIFIER

The preamplifier is composed of discrete transistors with a carefully matched dual differential pair, Q1, at the input. Q8 supplies constant current to the emitters of Q1A and Q1B, improving common mode rejection and assuring ideal differential operation. The base of Q1A receives the input signal, while the base of Q1B receives a portion of the output voltage fed back through R17 and R18. Conventional resistors become non-linear at the

high output voltages of the Citation 16. Because linearity is critical for low distortion, R17 and R18 are more expensive metal film resistors. The feedback through them sets the input sensitivity to 1.25 volts.

VR1 is preset at the factory for zero DC offset voltage at the output.

The difference between the base Q1A and the base of Q1B is called the error voltage. It is this voltage, rather than simply the signal input, which drives the amplifier. This dual differential pair is followed by nine transistors (Q2-7, Q9-11) arranged in three "current mirrors." Current mirrors accurately transfer current from one branch of a circuit to another. For example, the collector current of Q1B is precisely repeated in the collector currents of Q4 and Q9. Current mirrors take the place of conventional transistor/resistor configurations. Harman Kardon engineers have found that designs employing current mirrors can sound better than similar designs without them, even when the measured performance is identical.

When the collector currents of Q1A and Q1B are equal, the collector current leaving Q7 equals the collector current entering Q9. The preamplifier is then quiescent and no signal is delivered to the driver stages. When the collector currents of Q1A and Q1B are different, the current leaving Q7 will be different from the current entering Q9. That difference flows into R15, causing an output signal.

Under normal circumstances, the error voltage between the bases of Q1A and Q1B is only a few millivolts. But when the amplifier receives a large, fast-rising transient input, the output stage may not be able to slew quickly enough to keep pace. When this happens, the output voltage fed back through R17 and R18 is very different from the input. Consequently, the error voltage can become so large that it saturates the first stage. (This situation is common among all amplifiers which employ feedback.) During saturation a condition of transient intermodulation distortion exists where the output of the amplifier bears no resemblance to the input.

An amplifier may, for example, receive a full-scale transient input with a rise time of 1 microsecond. If, as a result, the amplifier develops 100 volts peak-to-peak at the output and slews at the typical rate of 8 volts per microsecond,

TECHNICAL DESCRIPTION (Cont'd)

then the output rise time will be 12.5 microseconds and the first stage will be saturated for about 11.5 microseconds. Because the Citation 16 has an unusually fast slew rate of 30 volts per microsecond, saturation time in this example would be reduced to about 2 microseconds. For transient inputs that produce less than 100 volts peak-to-peak (full scale), performance is better still. At about one half full scale and below, the output of the Citation 16 follows the input with no saturation—and no transient intermodulation distortion whatsoever.

THE DRIVER

The driver stages are symmetrical, complementary and operate in class A. This complimentary arrangement handles large voltage swings better than a single class A driver. A single driver has no trouble in pulling the output down, because it can be turned on hard and can sink the base current of the large drivers, as well as any capacitor currents. Getting the output to rise is another matter. The best single class A driver can do is to turn off and allow the rise from full negative to full positive to be controlled by the time constant of the load resistors and circuit capacity. Symmetrical class A is much faster, and it helps the Citation 16 achieve its excellent slew rate.

The single-ended output of Q7 and Q9 drives the push-pull complementary pair of Q12 and Q13. When the preamp output rises, the collector current of Q12 increases, while the collector current of Q13 decreases by the same amount. An inner feedback loop also goes to Q12 and Q13. The upper half of the loop is controlled by R20 and R21, while the lower half is controlled by R22 and R23. The push-pull pair of Q15 and Q17 provide the voltage gain of the driver. Since temperature differences between Q15 and Q17 may cause DC drift at the output, identical heat sinks hold both at essentially the same temperature. Q21 and Q22 add a stage of current gain, which is necessary to drive the output devices.

THE BIAS CIRCUIT

Two Darlington transistors keep the bias current constant over the entire temperature range of the amplifier. Without compensation, the current would tend to increase with the normal increase in the unit's temperature. This

would make the amplifier hotter still, leading to thermal runaway. While diodes in series can compensate for thermal changes, they don't track as accurately as transistors. Simple transistors don't track as accurately as Darlington's. Darlington's were chosen for the Citation 16 as the best possible solution to the problem. One of them, Q11, monitors the temperature of the heat sink; but this thermal check is not enough. Since other biased devices are mounted on the driver board, another Darlington, Q18, is mounted on the board itself and monitors that thermal environment.

The bias is adjusted by VR2, which is preset at the factory.

CURRENT FOLDBACK CIRCUIT

A current foldback circuit protects the amplifier from damage resulting from short circuits and overloads at the output. The limiting action reduces current to a point where the heat dissipation of the output transistors remains tolerable under short circuit conditions. The circuit will allow the amplifier to deliver full current into 4 ohms (11.1 amperes) and higher impedances. Below 4 ohms, the lower the load impedance is, the less current the Citation 16 will deliver. At zero ohms the current is limited to about 8 amperes.

Transistors Q19 and Q20 fold back the output current by pulling base current from Q21 and Q22, the last stage of the driver. Q14 and Q16 offer a second line of defense by similarly protecting Q15 and Q17.

III. OUTPUT STAGE

The output stage of the Citation 16 is a quasi-complementary, class AB design. The stage uses NPN transistors throughout, thus obviating the critical matching of several PNP and NPN devices. The NPN transistors used are much faster than the corresponding PNP devices currently available, resulting in excellent slew rate and extended power bandwidth. Stages composed only of NPN devices are also much more reliable than stages using matched NPNs and PNPs.

Most class AB amplifiers operate in class A until about 0.1 watt of output, and in class B for higher power levels. While class B offers greater efficiency, it also introduces crossover notch distortion which has been identified by

TECHNICAL DESCRIPTION (Cont'd)

some as the cause of harshness and "transistor sound." Psychoacoustic studies have shown that audible crossover distortion is eliminated if the transition from class A to class B is 17dB below full output, or higher. This calls for more extensive class A operation than conventional class AB amplifiers offer. On the Citation 16, the level 17dB below full output corresponds to 2.5 watts; therefore, the Citation 16 is biased to operate in class A up to 2.5 watts.

Ten TO3 transistors are used for the output stage. Q1 drives Q3, 5, 7, and 9 for the power output of the positive half of the wave and Q2 drives Q4, 6, 8, and 10 for the negative half. The 0.5 ohm, 5 watt emitter resistors assure proper current sharing among the transistors.

HEAT SINKS

Large, black-anodized aluminum heat sinks dissipate the heat of the output transistors. Because the output stage is driven so far into class A and requires substantial bias current at idling, sustained idling will bring the heat sinks up to about 60°C. At one-third of full power output the transistors are hottest. Sustained output at one-third of full power will increase the heat sink temperature to no more than 80°C. At full output, the temperature of the sinks is typically 75°C.

A thermal breaker cuts the AC input when the heat sinks are 90°C or hotter, and resets automatically when the temperature decreases.

OUTPUT SHAPING NETWORK

The output network (L1, C1, R1, R2) provides the shaping required for good square wave response and contributes to the stability of the amplifier. In particular, L1 isolates the feedback circuit from the effects of capacitive loads at high frequencies, without losing significant amounts of output voltage. It is a large air core inductor which contributes less distortion than iron core toroid inductors.

IV. LED BOARD

The LED circuit provides visual inspection of the output level. With SW2 (IMPEDANCE SELECT) in the 4 ohm position, and SW3 (DISPLAY SENSITIVITY) in the one bar (I) position, the LED display shows power output into 4 ohm loads with a full-scale range of 4 watts. As shown on the table, the first green lamp is illuminated at an output level 30dB below 4 watts, the second green lamp at 24dB below 4 watts, etc. At 4 watts of output, all 8 lamps will be illuminated.

Moving SW2 to the 8 ohm position adds the divider, R4. This resistor is necessary because it takes more voltage to deliver 4 watts to 8 ohms than to 4 ohms. Moving SW3 changes the full-scale wattage to 16 watts at two bars (II), 64 watts at three bars (III), and 160 watts at four bars (IV). Output levels and voltages for SW3 in the one bar (I) position are shown on the following table:

TECHNICAL DESCRIPTION (Cont'd)

| dB Level | Lamp Color | Power Level (Watts) | Peak Volts | |
|----------|------------|------------------------|------------|--------|
| | | | 4 Ohms | 8 Ohms |
| 0 | Red | 4. | 5.65 | 8. |
| -3 | Red | 2. | 4.00 | 5.65 |
| -6 | Yellow | 1. | 2.82 | 4.00 |
| -9 | Yellow | .5 | 2.00 | 2.82 |
| -12 | Green | .25 | 1.414 | 2.00 |
| -18 | Green | .0625 | .707 | 1.00 |
| -24 | Green | .0156 | .354 | .500 |
| -30 | Green | .0039 | .177 | .250 |

The circuit operates by breaking down the base-emitter diode of transistors Q2 through Q9. This requires that about 1.1 volts be developed at all bases except Q6, which requires only 0.5 volts. (Q6 is a single transistor, where the others are Darlington.)

To supply the voltage directly, the amplifier would be connected to the bus that ties resistors R9, 10, 11, 12 and 13 together. R9 and R7 would divide 5.65 volts down to

1.1 volts, R10 and R18 would divide 4.00 volts down to 1.1 volts, etc. Unfortunately, the lamps would glow only dimly, lighting for the peak of the wave. Therefore, Q1, R3, and C1 are included to detect peaks and strengthen illumination. Since the small voltages equivalent to -18dB, -24dB and -30dB are not sufficient to break down the corresponding drivers, IC1 is needed to provide a boost to these transistors.

BRIDGE MODE (Monophonic)

CAUTION

To prevent electric shock and for continued protection against fire hazard the "bridge mode" modifications must be made by qualified service personnel.

In the bridge mode, Channel A (left) is driven by the input signal and operates in the conventional way, i.e. it has a gain of +28 so that a 1.25 volt input produces a 35 volt output that is in phase with the input. Channel B (right) is configured differently, however. The gain of this channel is changed to -1 so that a 35 volt input produces an output of 35 volts that is 180° out of phase with the input. If the output of Channel A is fed to the input of the modified Channel B we have the desired result for bridge operation - two outputs that are equal in amplitude but opposite in phase. The mode of operation is established by the location of two patching cables.

There is a short cable that patches points on the Channel B driver board; this is called "the short jumper", W2. There is a longer jumper that patches from Channel A driver to Channel B driver board; this is called "the long jumper" W3. Jumper information for the two modes of operation is according to Fig I and the following chart:

| MODE | SHORT JUMPER | LONG JUMPER |
|--------|--------------|------------------------------------|
| Stereo | E3 to E5 | E9 on Channel A to E6 on Channel B |
| Bridge | E3 to E2 | E8 on Channel A to E7 on Channel B |

For bridge mode the signal is to be connected to the left input.

When unit is in bridge mode, the null pot, VR1, on channel B must be adjusted for an output null of less than ±10 millivolts D.C.

SPEAKER CONNECTION

In order to operate in the "Bridge Mode", you must first perform the internal modifications shown in Figure #1. Once this is accomplished, your speaker must now be connected between the left (+) terminal (red), and the right (+) terminal (red). The (-) (GND) or black terminals of each channel are not used.

To accomplish this, using the two Banana Plugs supplied, simply connect one lead of your speaker to one terminal of one Banana plug, and connect the other lead of your speaker to one terminal of the other Banana plug. Connect the two Banana plugs, as shown in Figure II, making sure that each end of the Banana plug with the wire attached goes into the red receptacle.

The LED display in the Bridge Mode is the sum of each channel's individual display - ie: Stereo Mode, 160W-Chan A, 160W-Chan B is equal to 320W total in Bridge Mode.

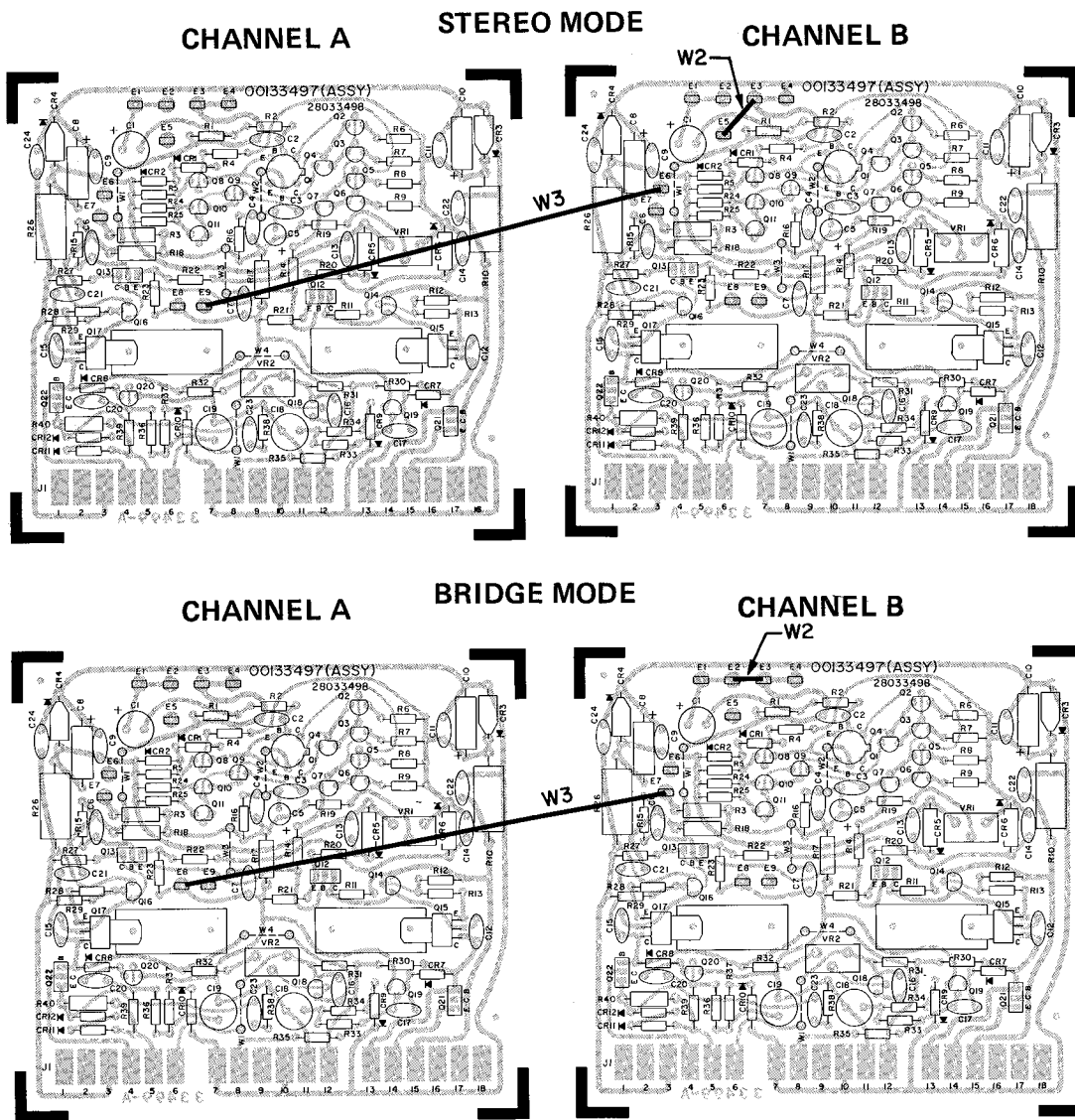

FIGURE I

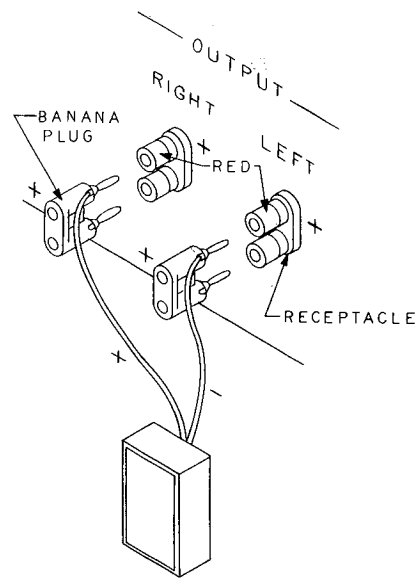
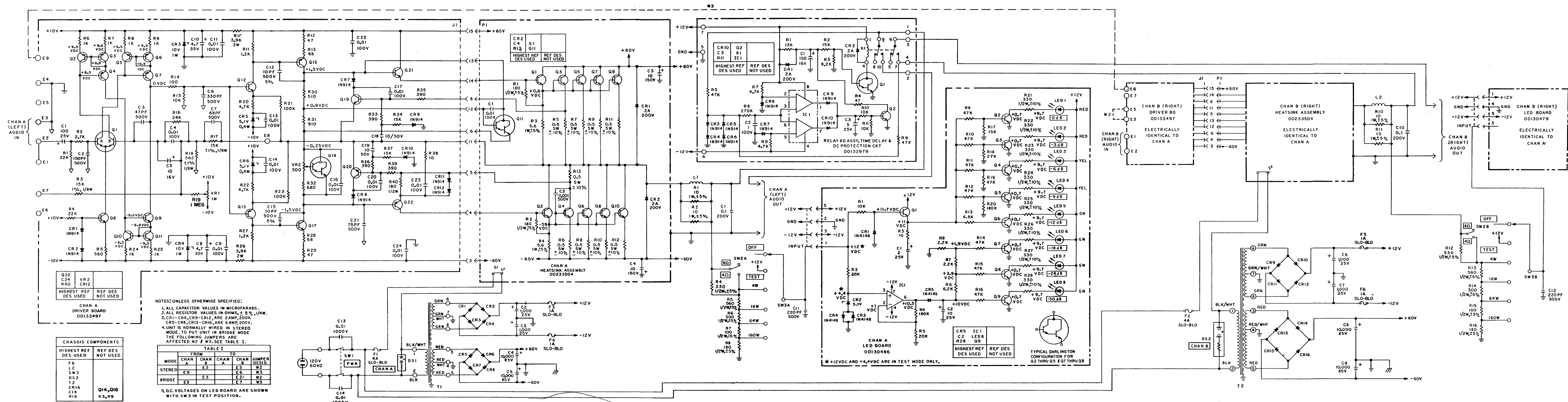

FIGURE II

REGULAR VOLTAGE SCHEMATIC DIAGRAM



- NOTES: UNLESS OTHERWISE SPECIFIED:
 1. ALL CAPACITOR VALUES IN MICROFARADS.
 2. ALL RESISTOR VALUES IN OHMS, ± 5% 1/4W.
 3. CR1-CR4, CR9-CR12, ARE 2AMP, 200V.
 CR5-CR8, CR13-CR16, ARE 6AMP, 200V.
 4. UNIT IS NORMALLY WIRED IN STEREO MODE. TO PUT UNIT IN BRIDGE MODE THE FOLLOWING JUMPERS ARE AFFECTED W2 & W3, SEE TABLE I.

TABLE I

| MODE | FROM | TO | JUMPER |
|--------|--------|--------|--------|
| STEREO | CHAN A | CHAN B | W2 |
| STEREO | E9 | E3 | E6 |
| BRIDGE | E9 | E3 | E2 |
| BRIDGE | E8 | E7 | W3 |

5. D.C. VOLTAGES ON LED BOARD ARE SHOWN WITH SW3 IN TEST POSITION.

CHAN A DRIVER BOARD 00133497

| HIGHEST REF DES USED | REF DES NOT USED |
|----------------------|------------------|
| F6 | |
| L2 | |
| S W3 | |
| DS2 | |
| T2 | |
| CR16 | Q14, Q16 |
| C14 | R3, R9 |
| R16 | |

CHAN A LED BOARD 00130486

| HIGHEST REF DES USED | REF DES NOT USED |
|----------------------|------------------|
| CR5 | IC1 |
| C2 | LED8 |
| R28 | Q9 |

REGULAR VOLTAGE SCHEMATIC DIAGRAM

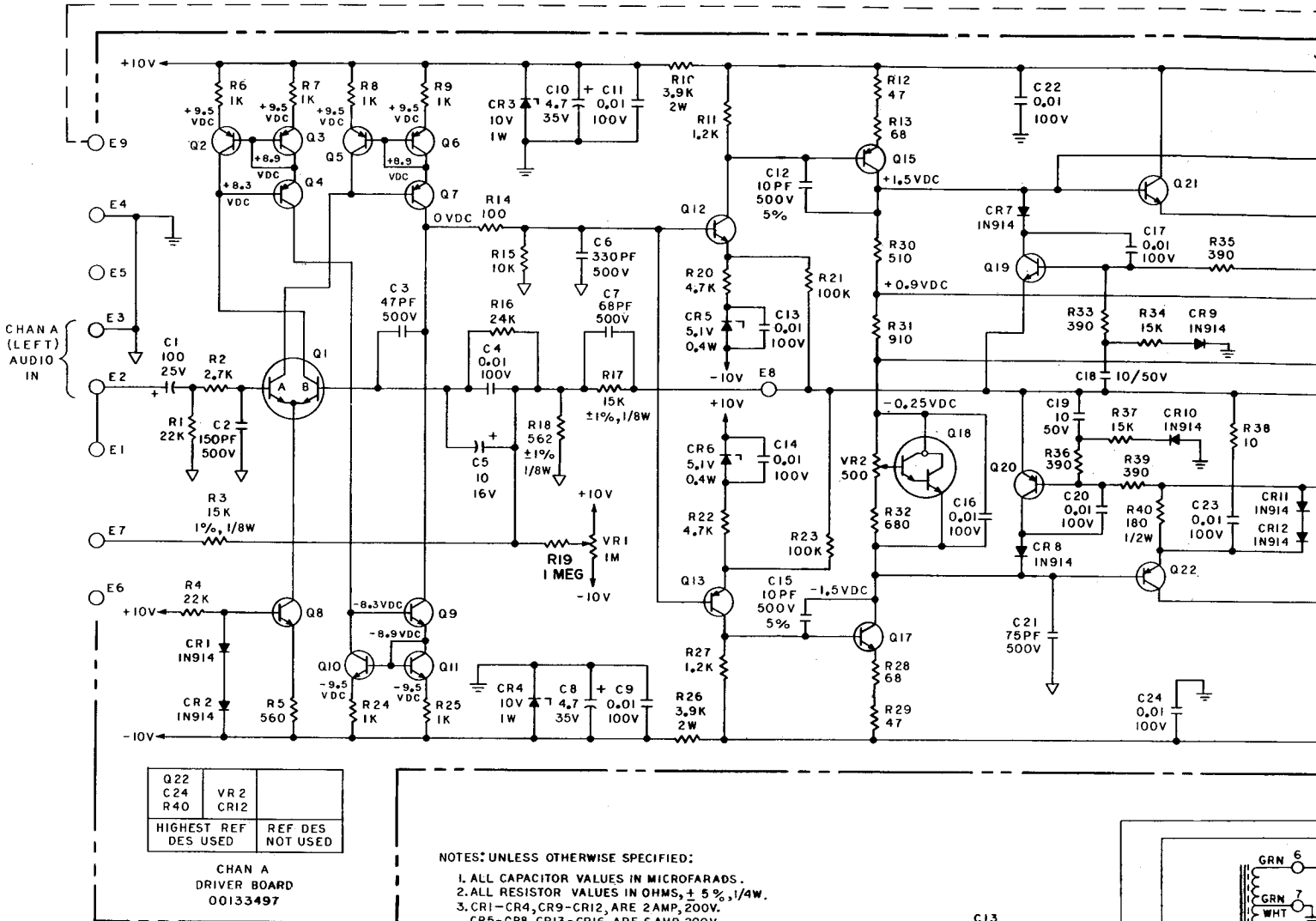

| | | |
|----------------------|------------------|--|
| Q22 | VR2 | |
| C24 | CR12 | |
| R40 | | |
| HIGHEST REF DES USED | REF DES NOT USED | |

CHAN A
DRIVER BOARD
00133497

| CHASSIS COMPONENTS | |
|----------------------|------------------|
| HIGHEST REF DES USED | REF DES NOT USED |
| F6 | |
| L2 | |
| SW3 | |
| DS2 | |
| T2 | |
| CR16 | Q14, Q16 |
| C14 | R3, R9 |
| R16 | |

NOTES: UNLESS OTHERWISE SPECIFIED:

1. ALL CAPACITOR VALUES IN MICROFARADS.
2. ALL RESISTOR VALUES IN OHMS, $\pm 5\%$, 1/8W.
3. CR1-CR4, CR9-CR12, ARE 2AMP, 200V.
4. CR5-CR8, CR13-CR16, ARE 6AMP, 200V.
5. UNIT IS NORMALLY WIRED IN STEREO MODE. TO PUT UNIT IN BRIDGE MODE THE FOLLOWING JUMPERS ARE AFFECTED W2 & W3. SEE TABLE I.

| MODE | FROM | | TO | | JUMPER DESIG |
|--------|--------|--------|--------|--------|--------------|
| | CHAN A | CHAN B | CHAN A | CHAN B | |
| STEREO | E9 | E3 | | E5 | W2 |
| | E8 | E3 | | E6 | W3 |
| BRIDGE | E9 | E3 | E2' | E2 | W2 |
| | E8 | E3 | E7 | E7 | W3 |

5. D.C. VOLTAGES ON LED BOARD ARE SHOWN WITH SW3 IN TEST POSITION.

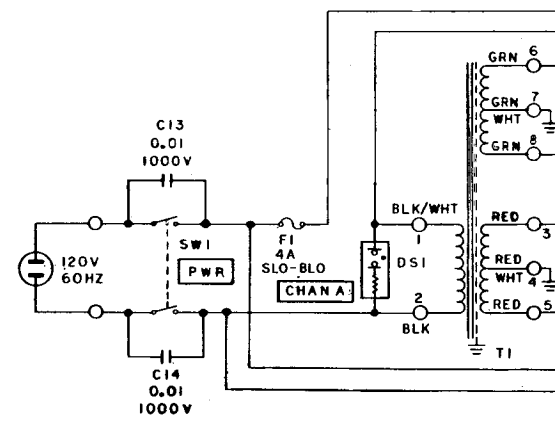

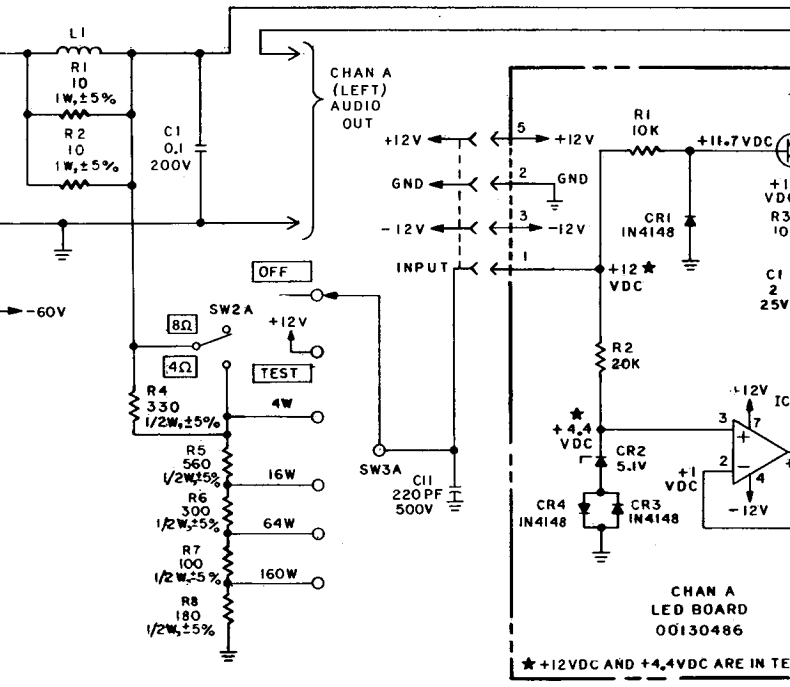
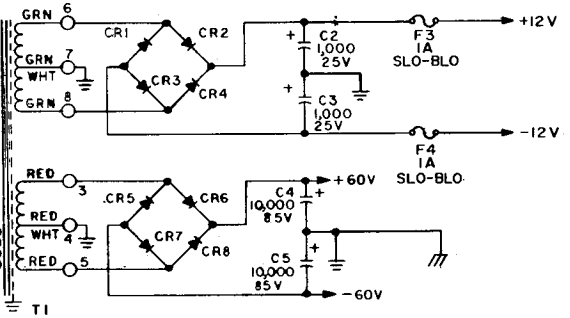
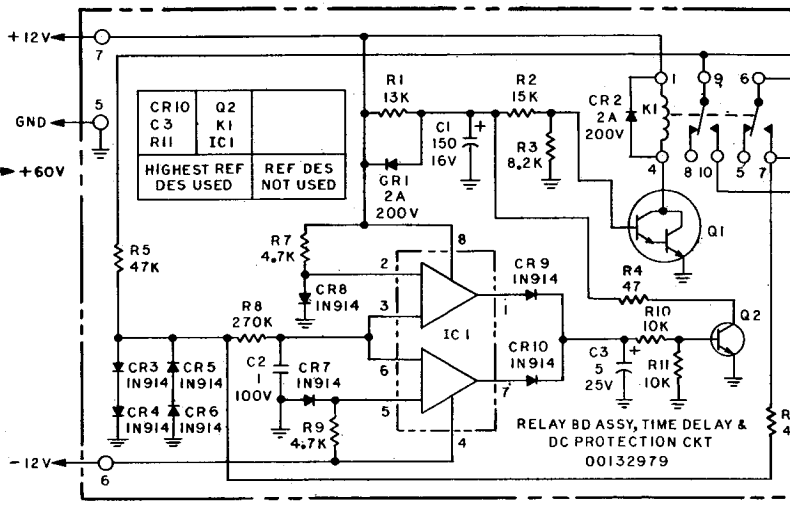
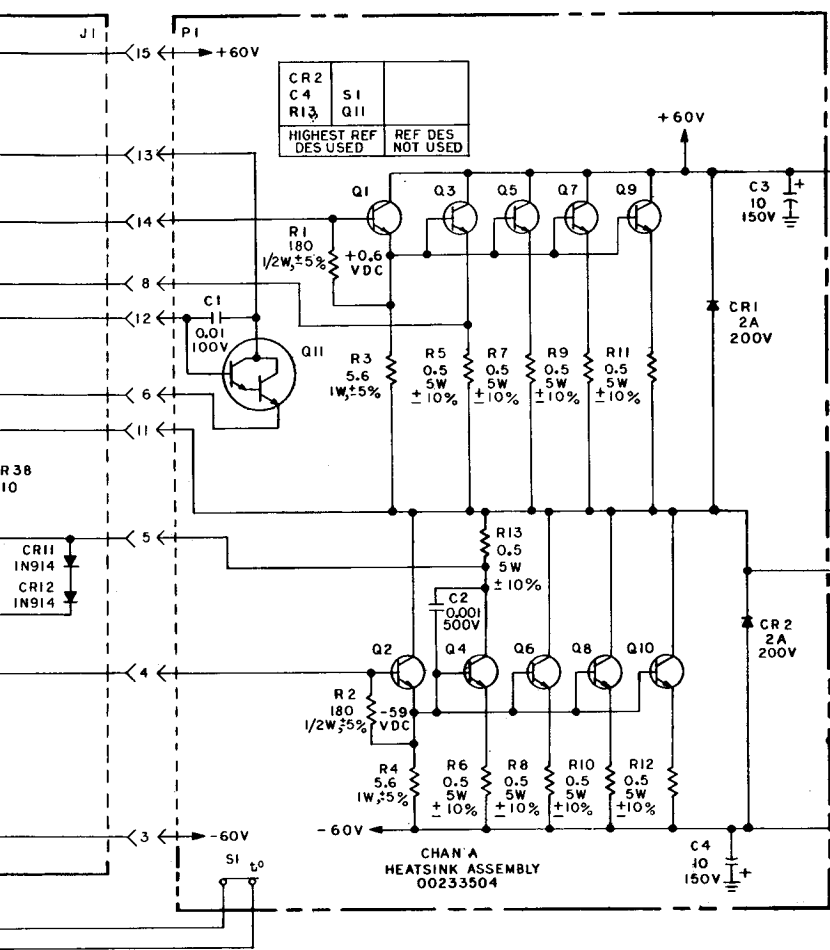

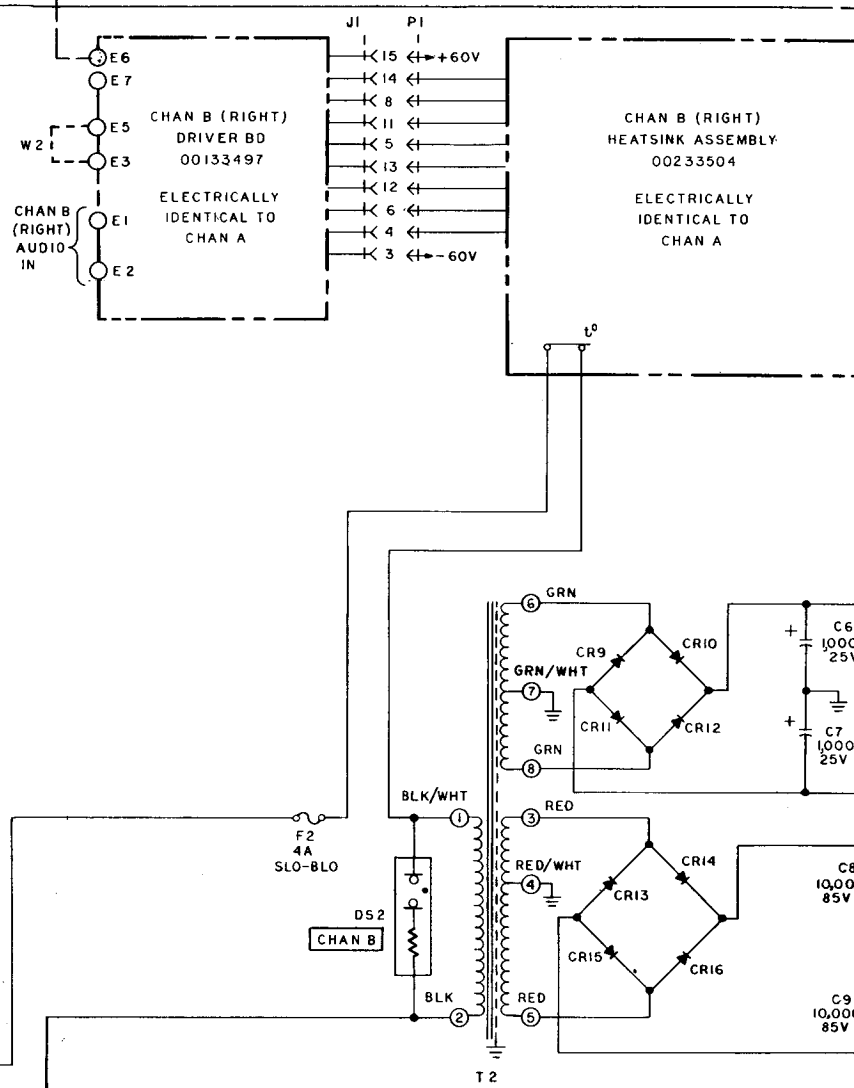
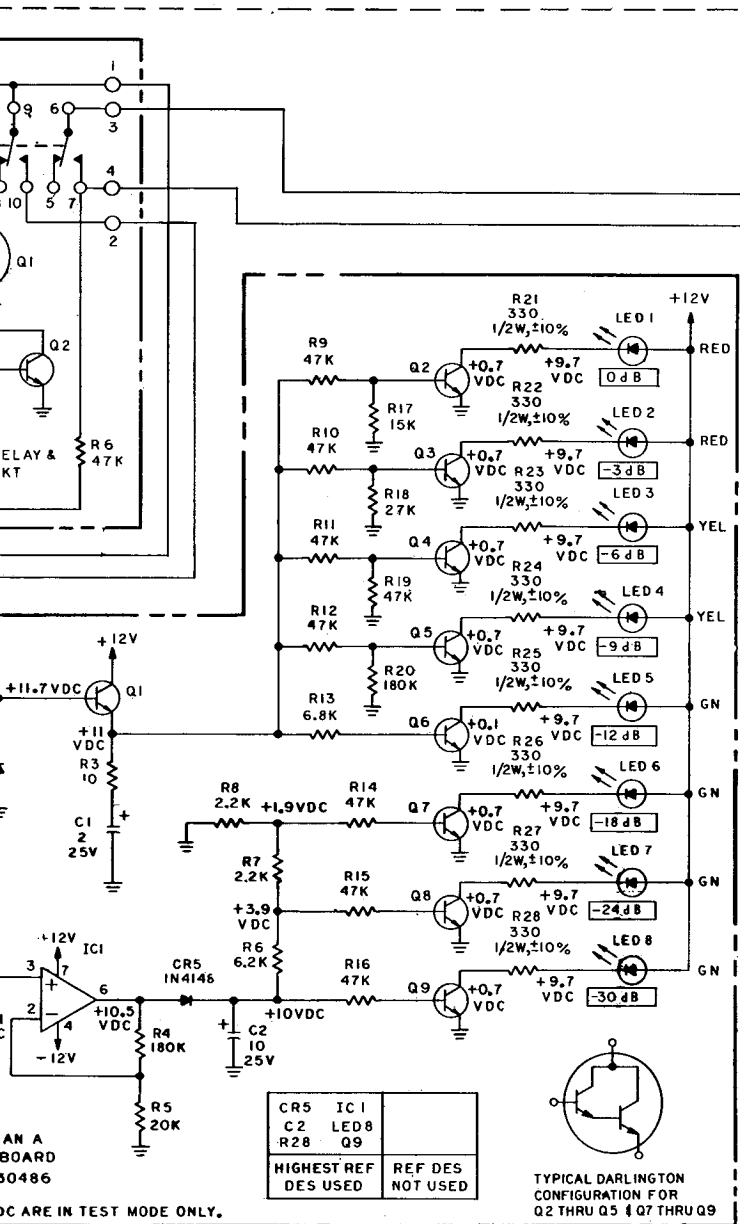

AN A BOARD 30486
DC ARE IN TEST MODE ONLY.

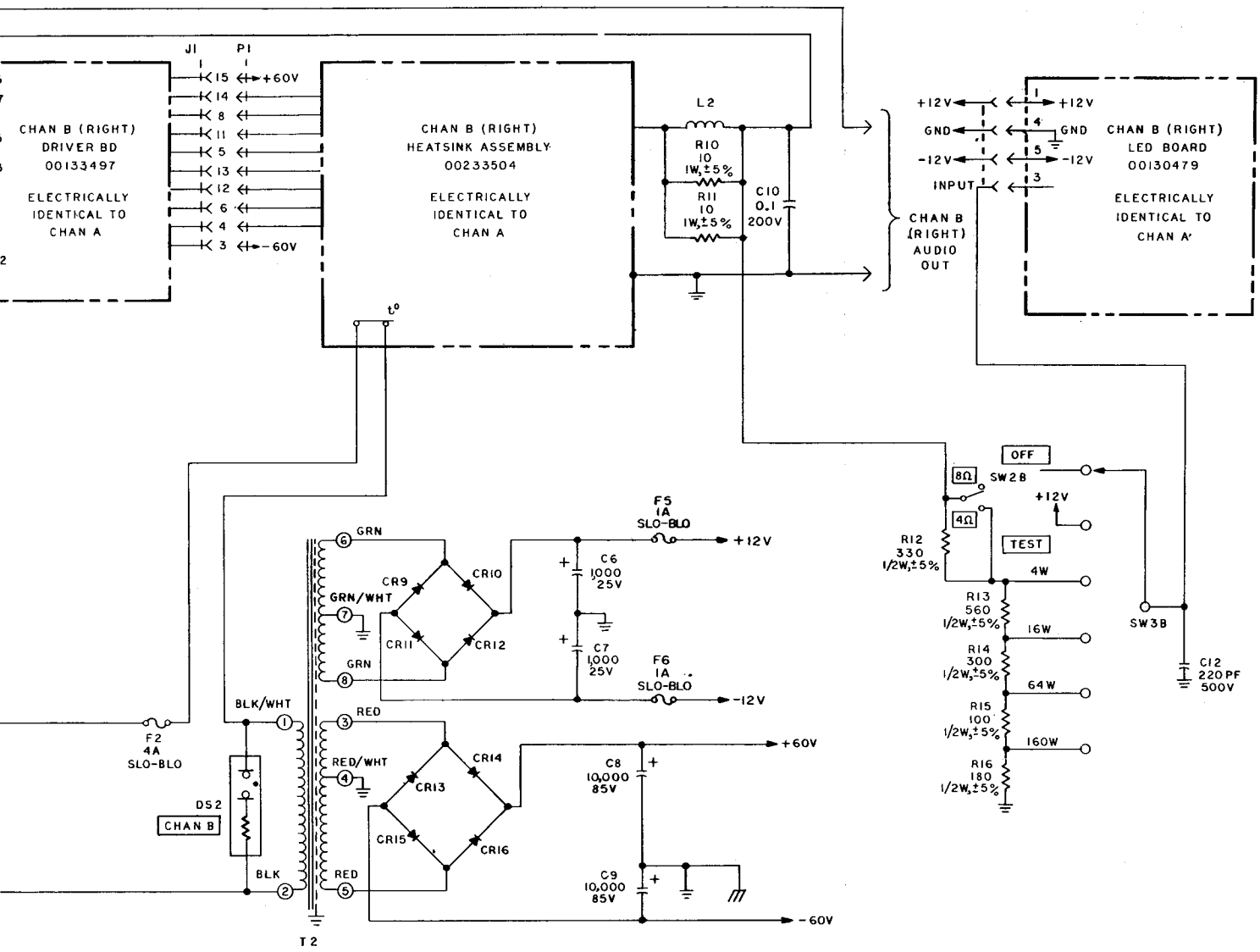

FIGURE III

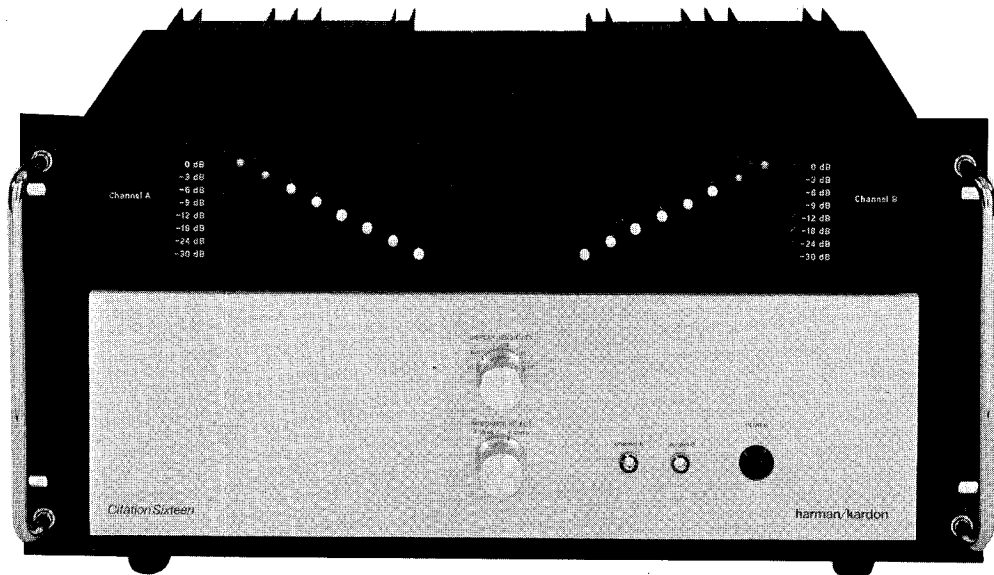
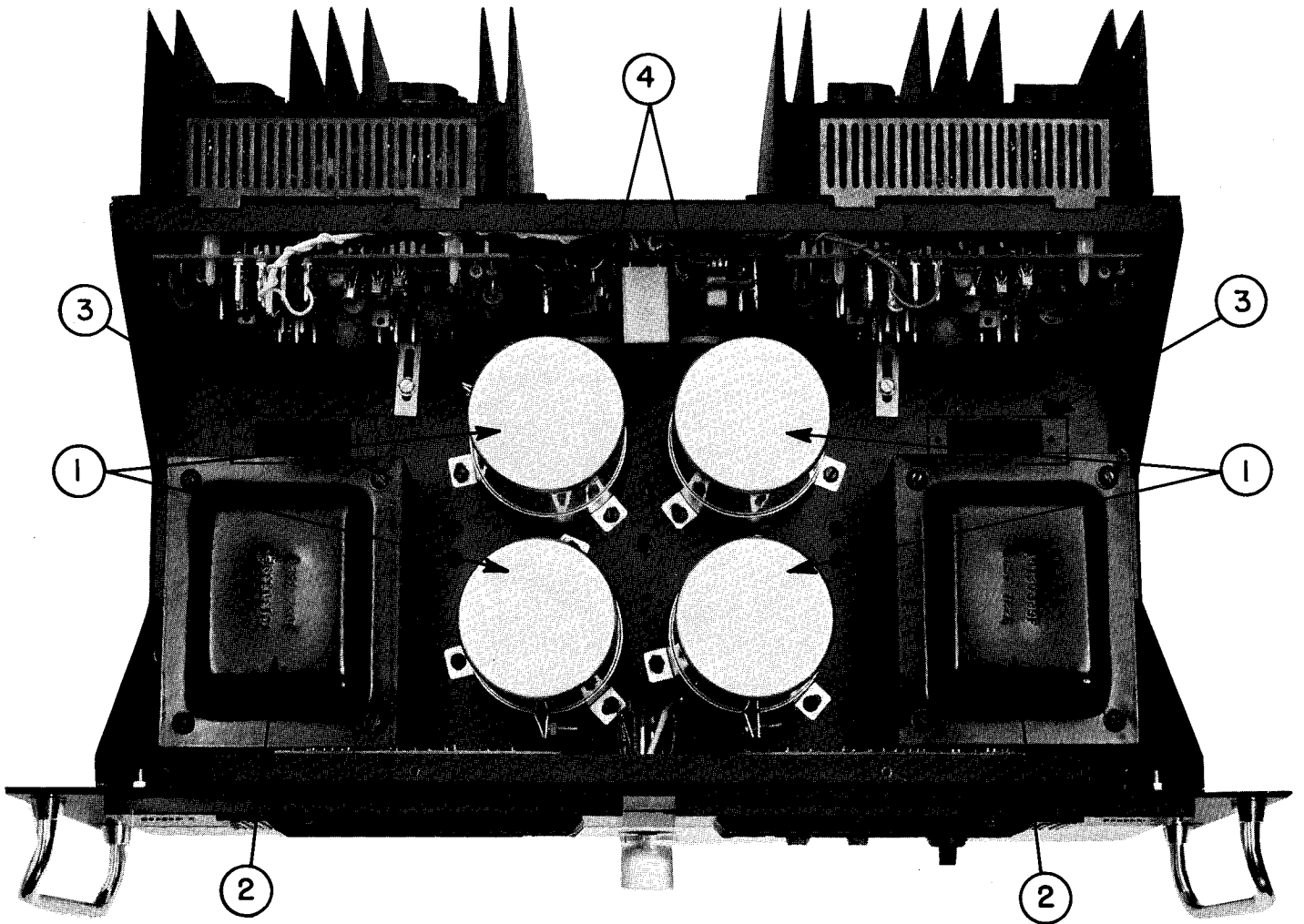
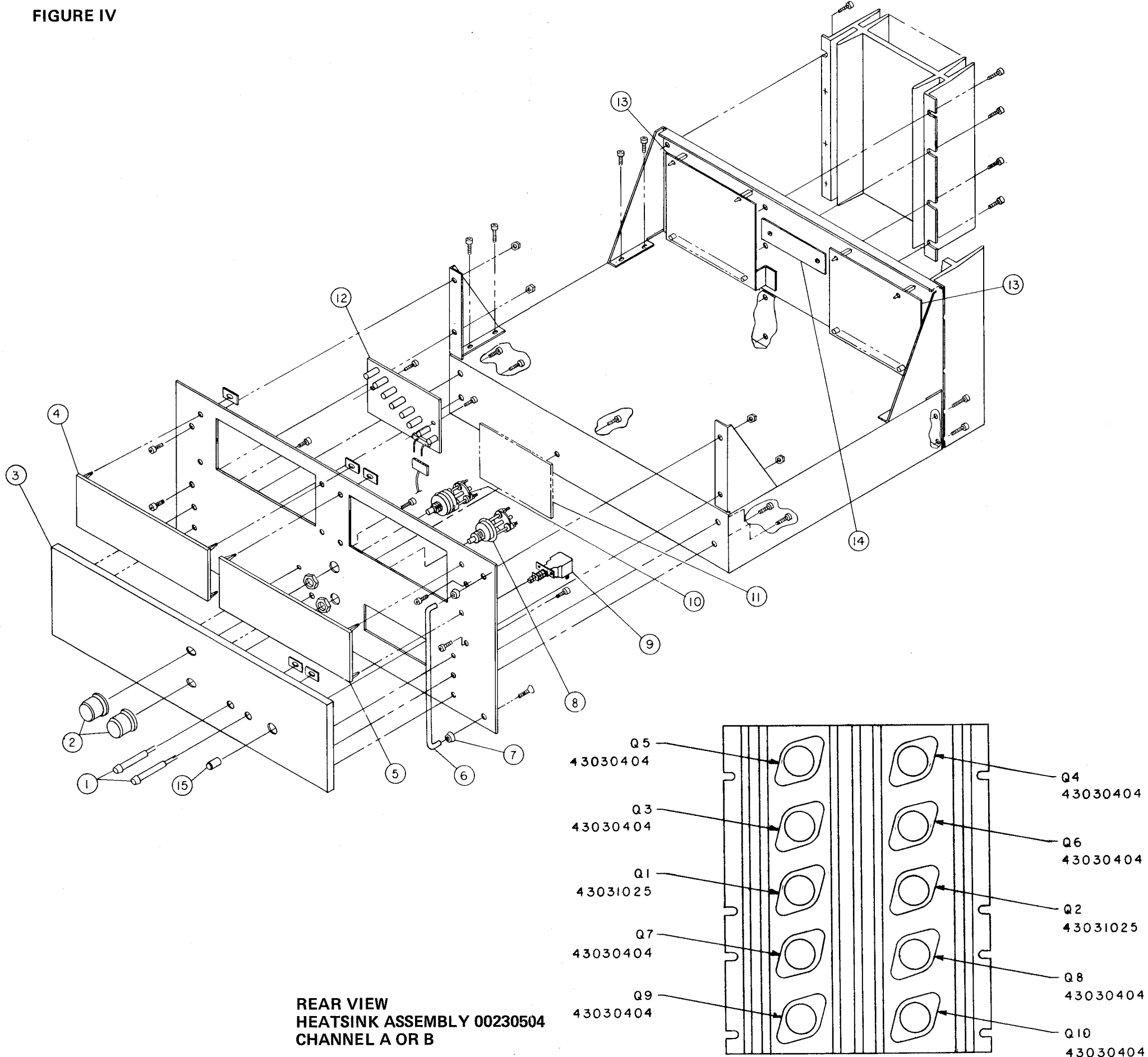
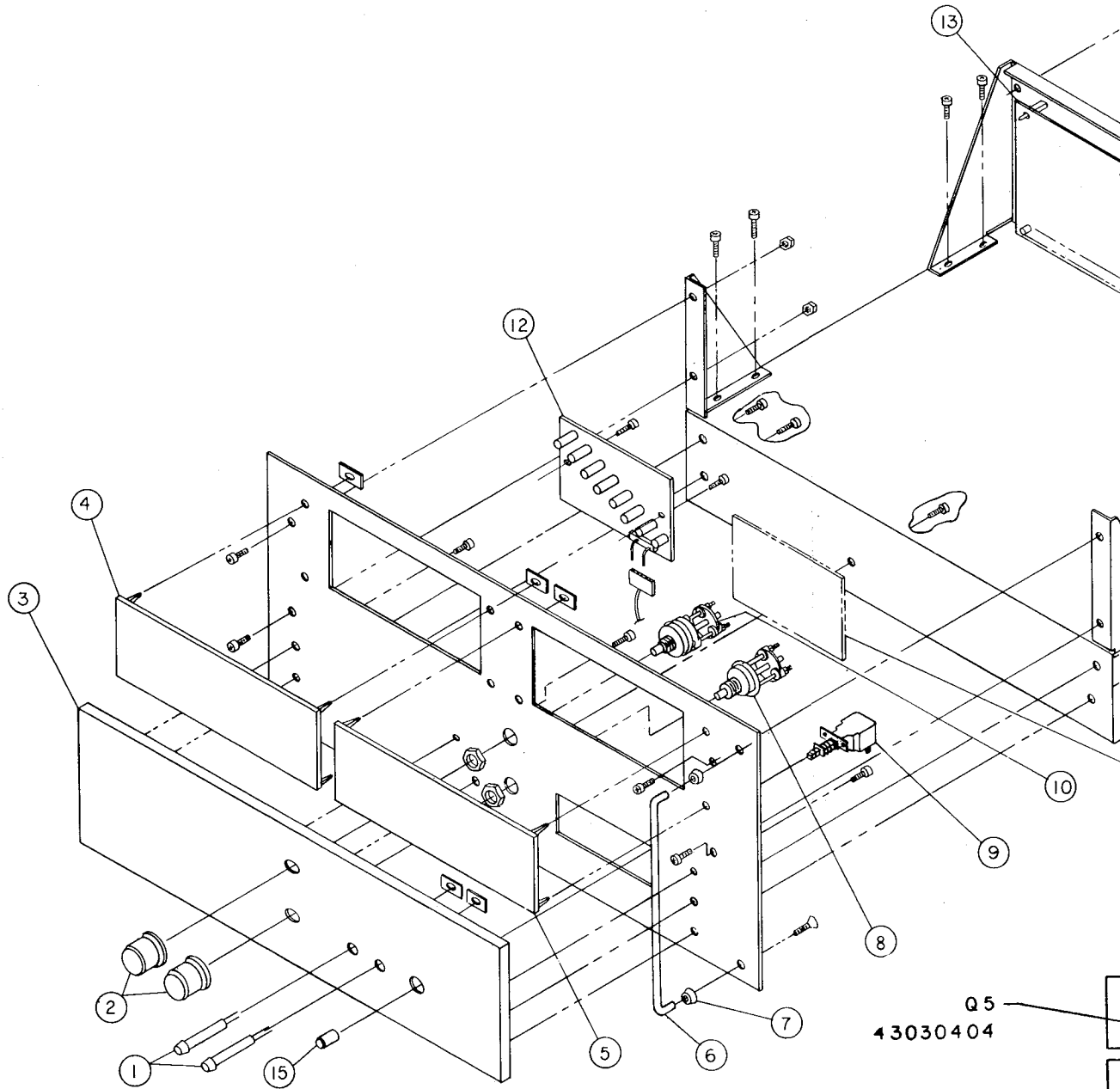

FIGURE IV



REAR VIEW
HEATSINK ASSEMBLY 00230504
CHANNEL A OR B

FIGURE IV



Q5
43030404

Q3
43030404

Q1
43031025

Q7
43030404

Q9
43030404

REAR VIEW
HEATSINK ASSEMBLY 00230504
CHANNEL A OR B

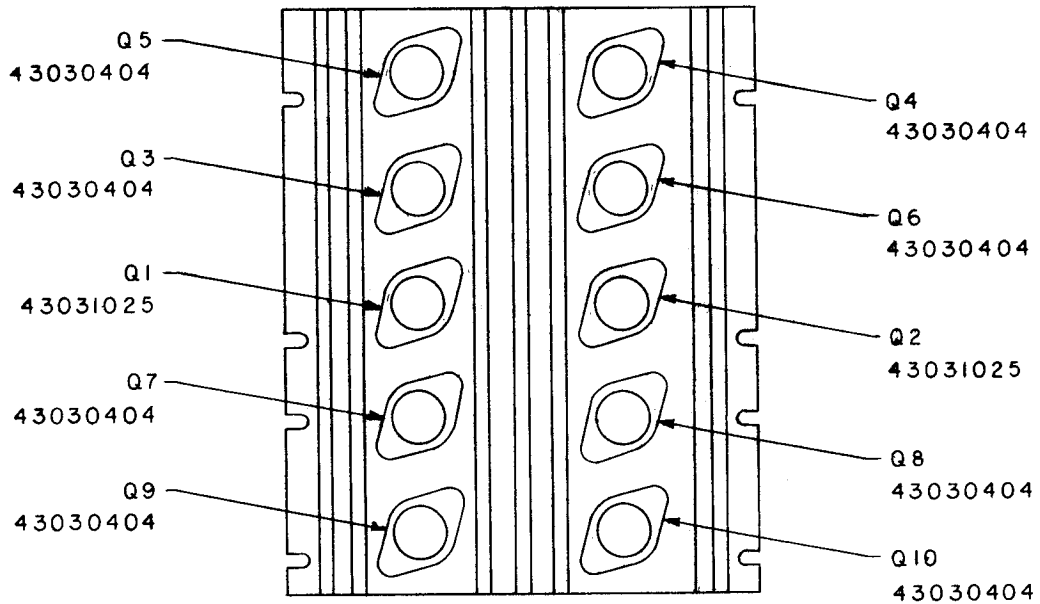
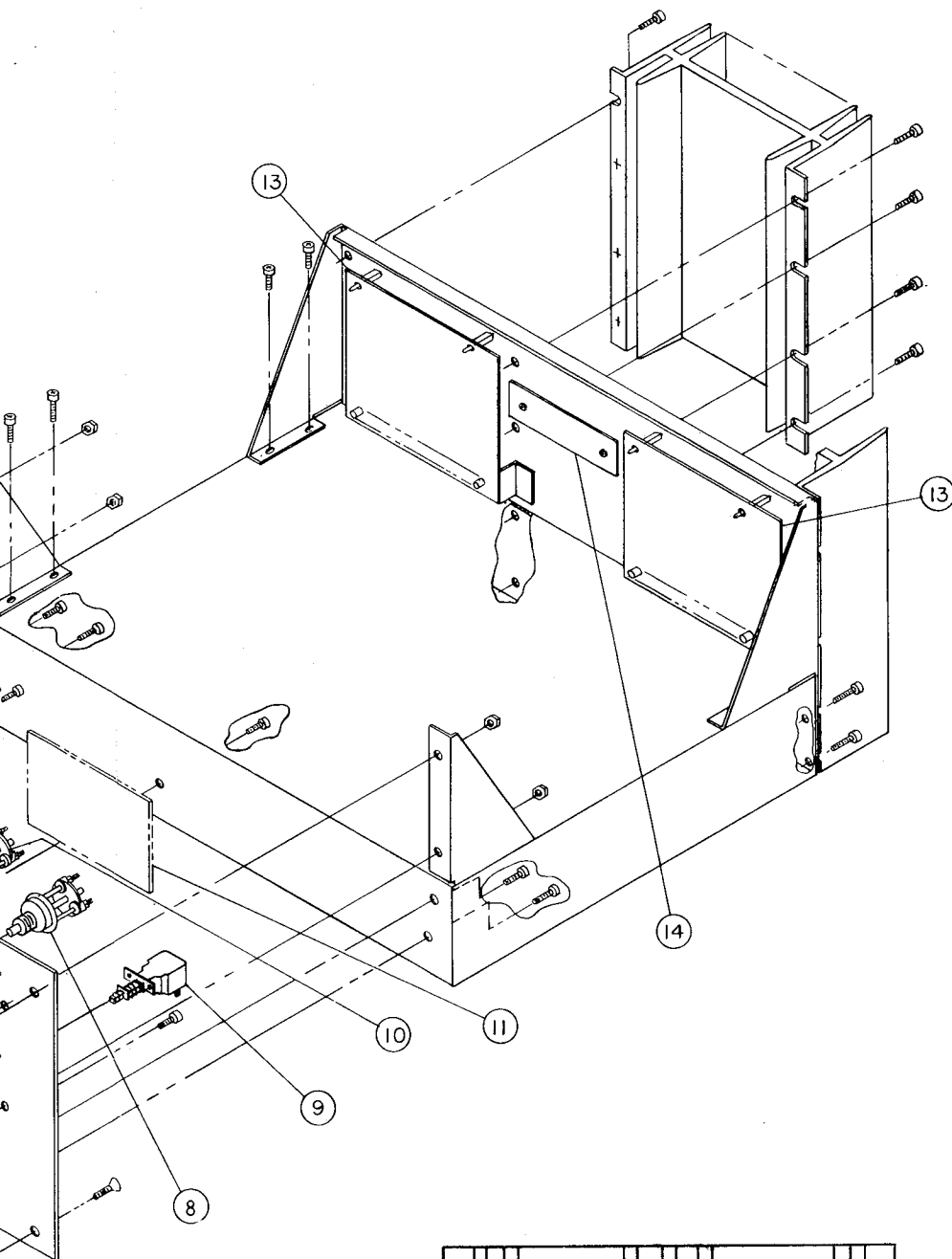

Y 00230504

MAIN CHASSIS PARTS LIST

| FIG. NO. | REF. DES. | H/K PART NO. | DESCRIPTION |
|----------|-------------|--------------|----------------------------------|
| III-1 | C4,5,8,9 | 31130322 | Capacitor, Lytic, 10000UF, 85V |
| III-2 | T1,2 | 10130339 | Transformer, Power |
| III-4 | L1,2 | 12030402 | Output Inductor |
| IV-1 | DS1,2 | 47626247 | Pilot Light Assy, (Neon) Red |
| IV-2 | | 00233528 | Knob, Subassy |
| IV-3 | | 6303305 | Panel, Dress |
| IV-4 | | 63033548 | Panel, LED Dress |
| IV-5 | | 63033549 | Panel, LED Dress |
| IV-6 | | 62130377 | Handle |
| IV-7 | | 62130466 | Ferrule, Handle |
| IV-8 | SW2 | 24030338 | Switch, Impedance Selector |
| IV-9 | SW1 | 25032217 | Switch, Pushbutton, Power, DPST |
| IV-10 | SW3 | 24030337 | Display Range Sensitivity Switch |
| IV-11 | | 00130479 | LED Display, Channel "B" Assy, |
| IV-12 | | 00130486 | LED Display, Channel "A" Assy. |
| IV-13 | | 00133497 | Driver Board Assy. |
| IV-14 | | 00132979 | Relay Board Assy. |
| IV-15 | | 63232189 | Knob, Pushbutton |
| Ref. | | 60129981 | Cover, Bottom |
| Ref. | | 62029267 | Feet, Mtg, 3/4 High |
| Ref. | | 60129979 | Cover, Wraparound |
| Ref. | CR-58,13-16 | 41630450* | Rectifier, Silicon, MR752 |
| Ref. | CR1-4,9-12 | 41029089* | Rectifier, Silicon, 2A, 200V |
| Ref. | C2,3,6,7 | 31521625 | Capacitor, Lytic, 1000UF, 25V |
| Ref. | | 65430392 | Post, Binding |
| Ref. | | 65427001 | Fuseholder w/Hardware |
| Ref. | F1,2 | 45023101* | Fuse, Slo Blo 4 Amp., MDX |
| Ref. | F3,4,5,6 | 45032236* | Fuse, Slo Blo, 1 Amp, MDL-1 |

HEATSINK ASSEMBLY

| | | | |
|------|-------|-----------|--------------------------|
| Ref. | Q11 | 43029832* | Transistor, NPN, MPS A13 |
| Ref. | | 67029563 | Clip, Transistor |
| Ref. | S1 | 45530336 | Terminal Cutout |
| Ref. | C3,4 | 31530452 | Capacitor, 10UF, 150V |
| Ref. | CR1,2 | 41029089* | Diode, Silicon, 2A, 200V |
| Ref. | Q1,2 | 43031025* | Transistor, NPN, Power |
| Ref. | Q3-10 | 43030404* | Transistor (RCA 1B05) |
| Ref. | Q3-10 | 43032928* | Transistor (RCA 1B04) |
| | | | Alternate Replacement |
| | | | Part for 43030404 |
| Ref. | | 66030343 | Socket, Transistor TO-3 |
| Ref. | | 61632266 | Cover, Insulating TO-3 |
| Ref. | | 85520110 | Washer, Mica TO-3 |
| Ref. | | 60130413 | Cover, Heatsink |

MULTIVOLTAGE

| | | | |
|-------|------|----------|--------------------------------|
| III-2 | T1,2 | 10130639 | Transformer, Power |
| III-3 | | 65427580 | Voltage Selector Connector Set |
| Ref. | F1,2 | 45031093 | Fuse, Slo Blo, 2 Amp, MDX |
| Ref. | | 65430519 | Fuseholder |

RCA
(609) 853
2241

MULTI VOLTAGE SCHEMATIC DIAGRAM

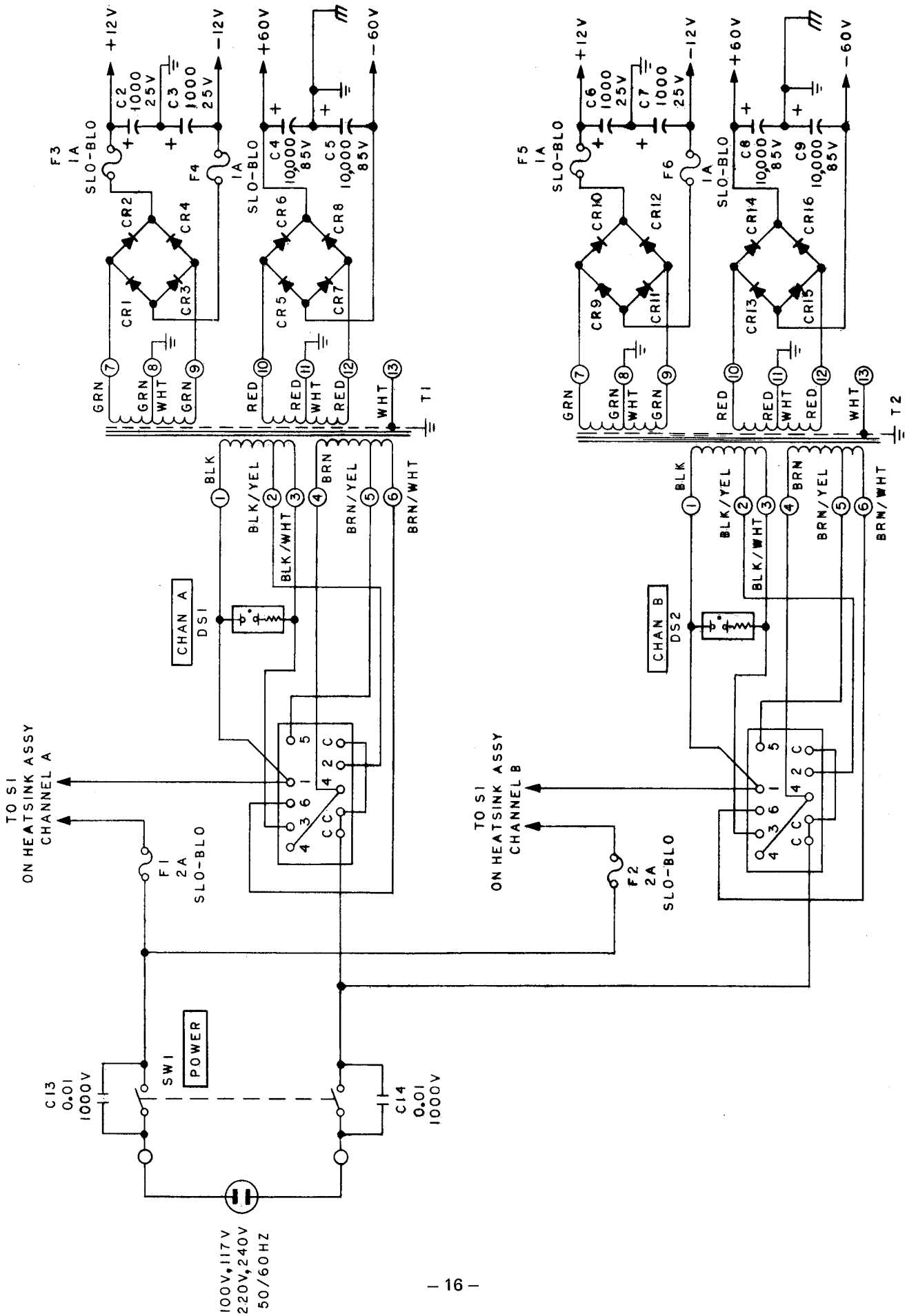

RELAY BOARD

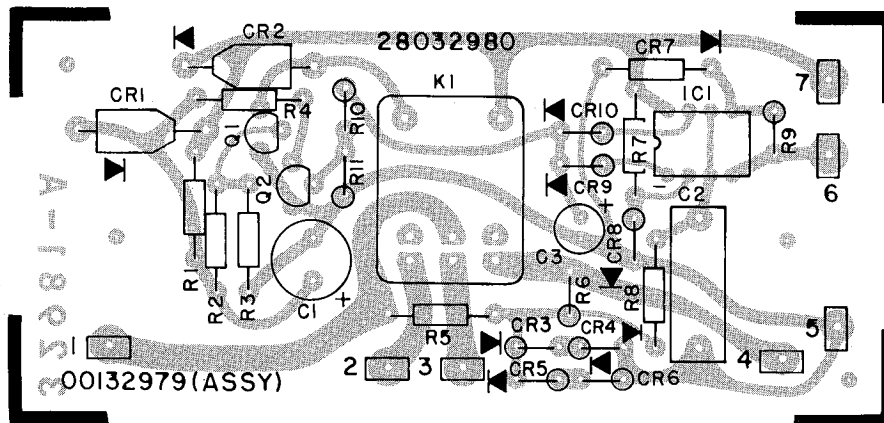

| CIRCUIT REF. NO. | H/K PART NO. | DESCRIPTION |
|---------------------------|--------------|----------------------------------|
| | 00131202 | P.C. Board Assy. Relay Board |
| CAPACITOR, LYTIC | | |
| C1 | 31840006 | 150UF, 16V |
| C3 | 31818905 | 4.7UF, 25V |
| DIODE | | |
| CR1, 2 | 41029089* | Silicon Pwr. 2A 200V |
| CR3-10 | 41629338* | Signal, Silicon, 1N914 |
| TRANSISTOR | | |
| Q1 | 43029832* | MPS-A-13 |
| Q2 | 43025972* | NPN, GP |
| RELAY | | |
| K1 | 13031208 | Potter Brumfield, R10-E2-W2-V185 |
| INTEGRATED CIRCUIT | | |
| IC1 | 43133061* | OP Amp, MC1458CP1 |

DRIVER BOARD CHANNEL A & B

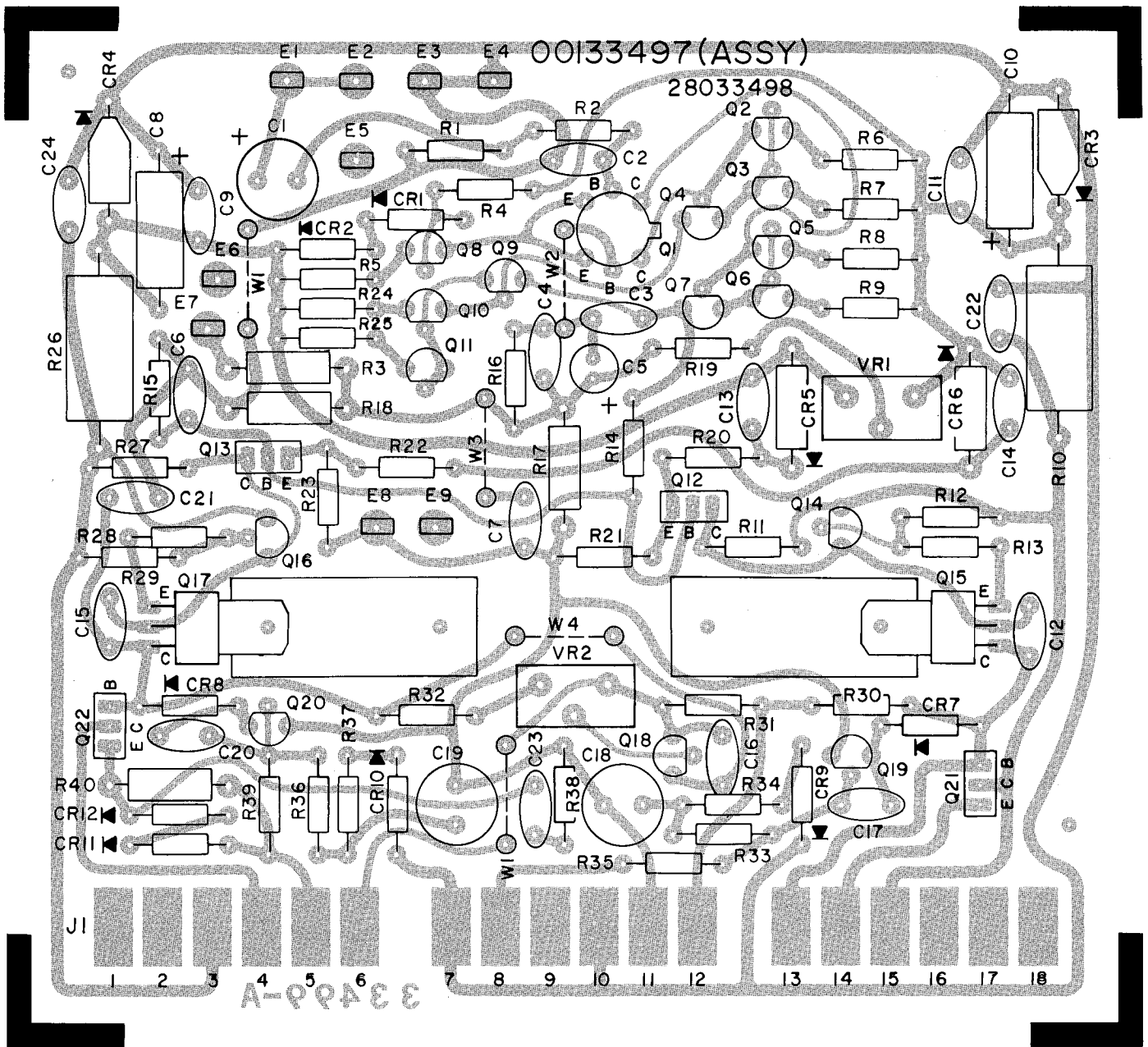

| CIRCUIT REF. NO. | H/K PART NO. | DESCRIPTION |
|-----------------------------|--------------|--------------------------------|
| | 00133497 | P.C. Board Assy, Driver |
| CAPACITOR, LYTIC | | |
| C1 | 31833231 | 100UF, 25V |
| C5 | 31833204 | 1UF, 50V |
| C8,10 | 31531721 | 4.7UF, 35V |
| C18,19 | 31833565 | 10UF, 50V, Non-Polar |
| DIODE | | |
| CR1,2,7-12 | 41629338* | Silicon, Signal IN914 |
| CR3,4 | 42020737* | Zener, 10V, 10%, 1W |
| CR5,6 | 42030498* | Zener 5.1V, 10%, 0.4W, MZ500-9 |
| TRANSISTOR | | |
| Q1 | 43034373* | Dual NPN Differential Pair |
| Q2-7, 20 | 43027722* | PNP GP |
| Q8-11, 19 | 43025972* | NPN GP |
| Q12,17 | 43030406* | NPN, MPS-U10 |
| Q13,15 | 43030407* | PNP, MPS-U60 |
| Q18 | 43029832* | NPN, MPS-A13 |
| Q21 | 43030408* | NPN, MJE340 |
| Q22 | 43030409* | PNP, MJE350 |
| RESISTOR, METAL FILM | | |
| R3,17 | 35111533 | 15K ohm, 1/8w, 1%, Dale M20P |
| R18 | 35130659 | 562 ohm, 1/8w, 1%, Dale M20P |
| RESISTOR, VARIABLE | | |
| VR1 | 21630493 | 1M ohm |
| VR2 | 21629833 | 500 ohm |

ALIGNMENT PROCEDURE ADJUSTMENTS

There are only two adjustments, the null pot VR1 and the idling current pot VR2. Both of these adjustments are to be made with no signals and no load. VR1 should be set so that the output of the amplifier is less than ± 10 millivolts D.C.

VR2 should be set for about 50 millivolts D.C. across one of the 0.5 ohm emitter resistors when the set is cold.

The easiest way to do this is to put one meter lead on the emitter of the upper left-hand output device on the heat sink and the other lead to the output terminal.

The 50 millivolt D.C. reading will change as the set heats up. Continue to readjust VR2 until the readings stabilize. This will be approximately 30 minutes. The heatsinks will now be at a temperature of approximately 60°C which is its quiescent value. At this time recheck the output of the amplifier and readjust VR1 if required.

LED BOARD CHANNEL A

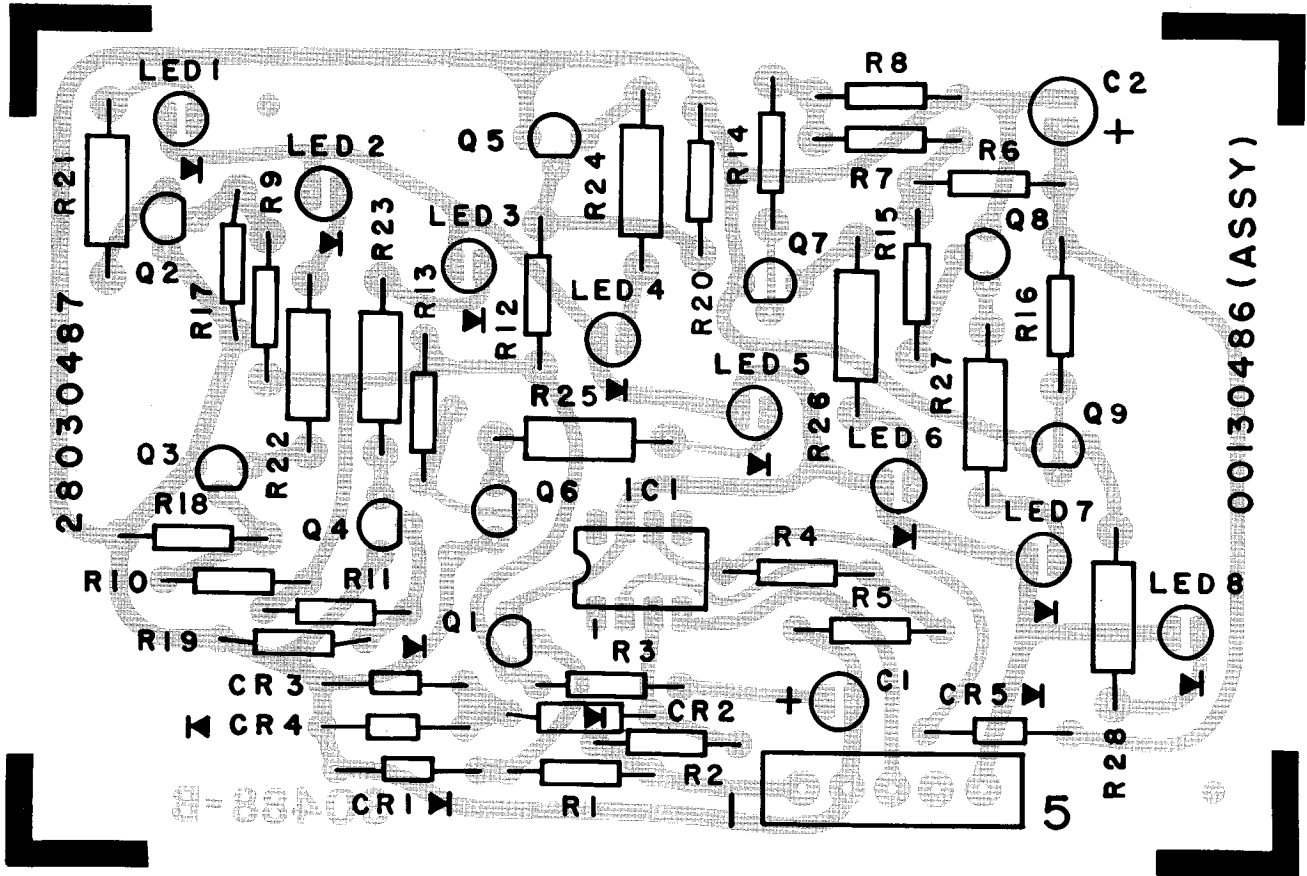

| CIRCUIT REF. NO. | H/K PART NO. | DESCRIPTION |
|---------------------------|--------------|---|
| | 00130486 | P.C. Board Assy., Led Display Chan. "A" |
| CAPACITOR, LYTIC | | |
| C1 | 31827111 | 2UF, 35V |
| C2 | 31819176 | 10UF, 25V |
| DIODE | | |
| CR1,3,4,5 | 41629897* | IN4148 |
| CR2 | 42030498* | Zener 5.1V, 0.4W, 10% MOT MZ500-9 |
| INTEGRATED CIRCUIT | | |
| IC1 | 43130636* | Operational Ampl. MC1741C |
| TRANSISTOR | | |
| Q1,6 | 43025972* | NPN GP |
| Q2-5,7,8,9 | 43029832* | MPS-A13 |
| LAMP SOLID STATE | | |
| LED1,2 | 46730574* | LED, Red |
| LED3,4 | 46730575* | LED, Yellow |
| LED5-8 | 46730576* | LED, Green |

LED BOARD CHANNEL B

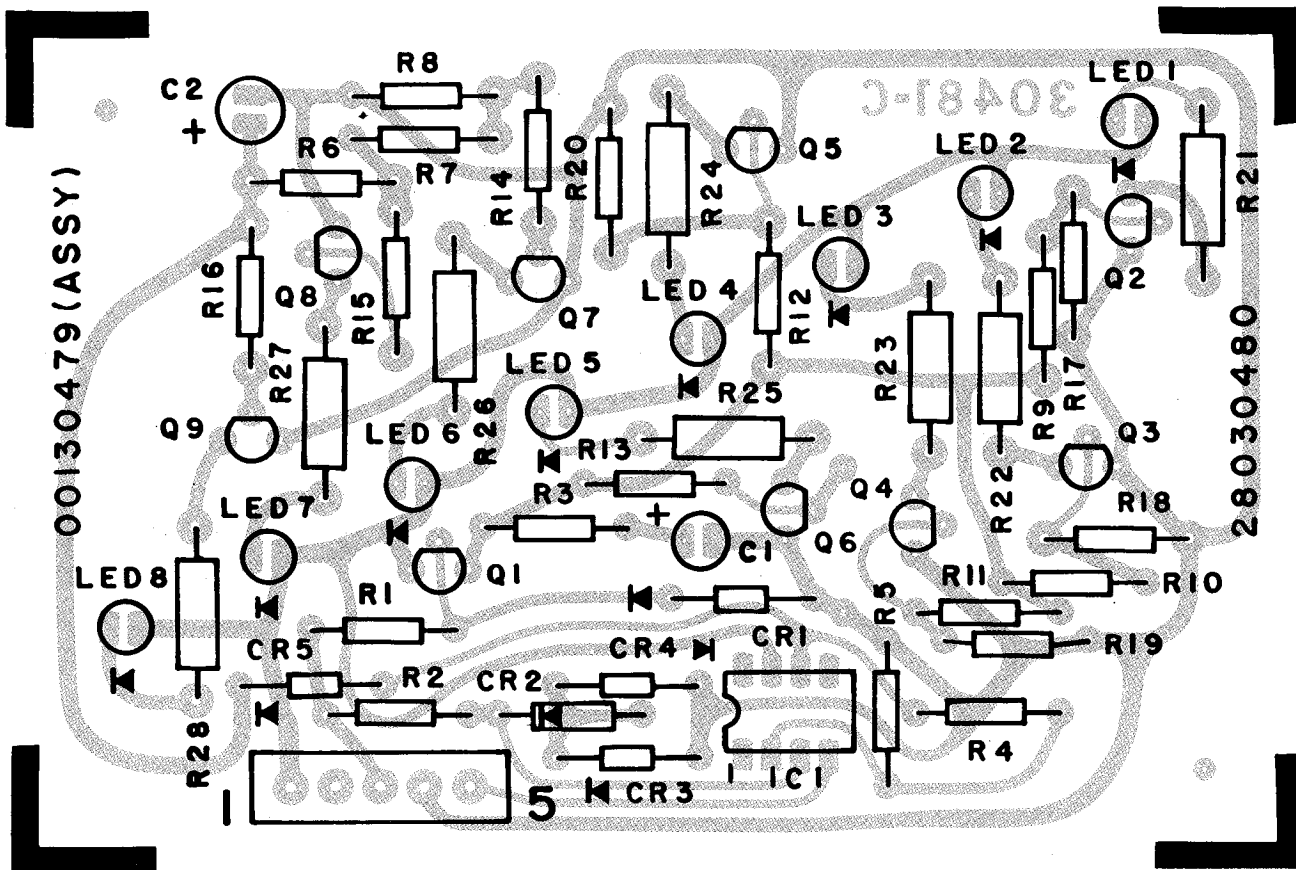

| CIRCUIT REF. NO. | H/K PART NO. | DESCRIPTION |
|---------------------------|--------------|---|
| | 00130479 | P.C. Board Assy., Led Display Chan. "B" |
| CAPACITOR, LYTIC | | |
| C1 | 31827111 | 2UF, 35V |
| C2 | 31819176 | 10UF, 25V |
| DIODE | | |
| CR1,3,4,5 | 41629897* | IN4148 |
| CR2 | 42030498* | Zener 5.1V, 0.4W, 10% MOT MZ500-9 |
| INTEGRATED CIRCUIT | | |
| IC1 | 43130636* | Operational Ampl. MC1741C |
| TRANSISTOR | | |
| Q1,6 | 43025972* | NPN GP |
| Q2-5,7,8,9 | 43029832* | MPS-A13 |
| LAMP SOLID STATE | | |
| LED1,2 | 46730574* | LED, Red |
| LED3,4 | 46730575* | LED, Yellow |
| LED5-8 | 46730576* | LED, Green |

NOTE TO WARRANTY STATIONS: Items marked by asterisk (*) are recommended spare parts stock. Printed circuit board assembly numbers are shown for reference only. Harman/Kardon does not normally supply assembled printed circuit boards.

NOTE: To speed handling of your order be sure to include both the model and serial numbers, in addition to the quantity, part number and part description of the items ordered. Orders from independent dealers, independent servicemen, and retail customers will be shipped on a cash in advance basis. Harman/Kardon reserves the right to substitute equivalent parts for those originally installed in this chassis. All parts should be ordered from Harman/Kardon, 55 Ames Court, Plainview, L.I., N.Y. 11803, Att: Parts Department.