

## SOUND AND VOICE MAGNIFIERS

BY

RAYMOND EVANS

The magnification of weak signals of a wireless receiver is now well understood. However, the various methods employed all make use of the "valve" as a magnifying medium. The method discussed in this article should prove of interest to experimenters as it utilises methods other than that of the valve in order to effect the necessary magnification.

The terms, sound-magnifier, voice-magnifier, note-magnifier and tone-magnifier, merely apply to the instrument or combination used to magnify or amplify the received audible notes or tones as heard in the telephones, not to amplify the high-frequency currents or oscillations which are above audibility; in simple terms, they are sound magnifiers, or loud speakers. In order that the "valve" may be made to function as a tone-magnifier, it must be connected inductively to the "plate" circuit of the preceding valve receiver, or in place of the phones in a crystal receiver per medium of an audio-frequency or iron-core transformer, as shown in figure 1.

It can readily be seen that this circuit will not magnify the high-frequency currents on account of the high impedance of the iron-core transformer windings, through which these currents would require to pass, but the low-frequency or note currents will pass through readily to the valve, where magnification will take place.

The first type of note-magnifier which will be dealt with in this article is that known as the microphonic relay. In its elementary form, which by the way is quite practicable, it consists of an electro-magnet introduced into the receiver in the position usually occupied by the telephone receivers.

The electro-magnet is arranged so that one or both of its poles are in close proximity to a diaphragm of thin sheet-iron to which is secured on its reverse side, a small button of hard carbon. From this it is obvious that any variation of the field of the electro-magnet due to received currents will have the effect of causing the diaphragm to vibrate. An adjustable screw with a contact-point of steel or hard carbon makes very light contact upon the carbon button on the diaphragm. An auxiliary circuit, including a four to 10 volt battery and telephones, is connected in series across the terminals of the microphonic contacts as shown in figure 2. These microphonic relays certainly do magnify the signals, but, unfortunately, weak signals are not magnified in nearly the same ratio as strong ones, while very weak signals will not magnify at all. The arrangement is so susceptible to ordinary mechanical vibrations that permanent sensitive adjustment is out of the question.

An improved type of microphonic relay developed by S. G. Brown has been used both singly and in cascade with good results. These relays have been so successfully used in the past by many of the Marconi high-power stations, using balanced crystal and Fleming valve receivers, that three or four relays in cascade produced such magnification that signals emanating from distances of from 3,000 to 4,000 miles could frequently be heard at a considerable distance from the telephone receivers.

In construction, the "Brown" relay consists fundamentally of a soft iron core whereon is wound two windings, a fine and a heavy winding, the finer one being wound upon

the ends of the magnet as shown and connected to the receiving circuit in place of the usual telephone receivers. This forms the input circuit of the relay. The heavier winding is connected at one end to a steel reed or vibrating tongue, on which is mounted a contact button of hard carbon. An adjustment screw is provided and fitted with a contact-point of an alloy of iridium and osmium and is poised in such a position by means of the micrometer adjustment, that very delicate contact can be made with the carbon button on the reed. The opposite end of the heavy winding is connected to the telephones, a battery of dry cells and thence to the contact-screw, as shown in figure 4.

This is the output circuit, and, in the case where several relays are used in cascade, the telephones are omitted and in their place the input terminals of the second relay are substituted and so on. The aforementioned micrometer adjustment is obtained by a movement of the knurled nut shown let into the base in figure 3. The "Brown" relay will also magnify voice currents without any appreciable harshness or distortion and considerable use has been made of it in this direction.

Another and perhaps more universally known instrument developed by the same engineer is the "Brown" telephone receiver, a diagram of which is shown in figure 7. This cannot be truthfully classed as a magnifier, but a telephone of considerably higher efficiency than the average, merely on account of its producing a greater volume of sound for a given value of current input. It consists essentially of an ebonite case in which is mounted a horse-shoe magnet (M) of hard steel, with pole-pieces of soft iron, upon which are the bobbins and windings. The resistance of the magnet windings varies, an average value being 750 ohms per receiver, but on account of the more universal use of telephone transformers, low resistances of about 75 ohms are now being used. A small steel reed (R) is placed with one end, as shown, immediately over the ends of the pole-pieces so as to obtain the maximum magnetic influence. This end of the reed is also secured to the centre of a diaphragm (D) of very thin aluminium, which, instead of being flat, is of a conical shape and unlike most receivers does not rest upon the receiver case but a short distance from it, a ring of tissue being cemented around the gap.

Another magnifier of considerable merit, the product of an American engineer, for use both as a magnifier of wireless signals and voice currents, is known commercially as the "Magnavox." This magnifier, which operates upon an electro-dynamic principle, gives out sound in exact proportion to the current put into it; of course, allowing for the efficiency of the electrical design of its windings. Figure 5 will give the reader an idea of the general arrangement of the parts, while figure 6 illustrates the electrical connections necessary for the magnification of weak wireless signals. A magnetic circuit (NS) which is almost closed, is energised by means of current from a local battery (b) passing through its windings. A coil of fine wire is placed centrally in the gap as shown in the magnetic circuit, and is connected to the terminals of the secondary of a small step-down transformer. The coil is secured by means of wax, cement, or shellac, to a diaphragm of mica about 0.002 inch in thickness. A large horn or megaphone is usual-

This article, which appeared originally in "Sea, Land and Air" in 1921, has been reproduced in the "Audio Topics" section of our magazine to give high-fidelity enthusiasts some idea of amplification methods in 1921. When the article was written, audio techniques were still in their infancy, and even the terminology was in some cases not firmly established. For example, the author refers to audio amplifiers

loosely as "loudspeakers," while the various transducers used for converting electrical energy to acoustic energy do not appear to have any generic term. The idea of using valve amplifiers to raise the output from detectors to a high enough level for normal listening was still new, but nevertheless well enough advanced to have laid the foundations for public address systems.

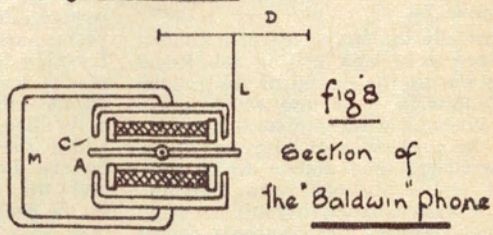
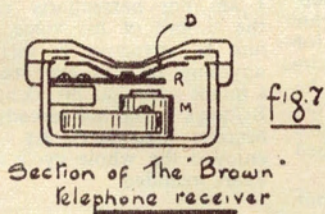
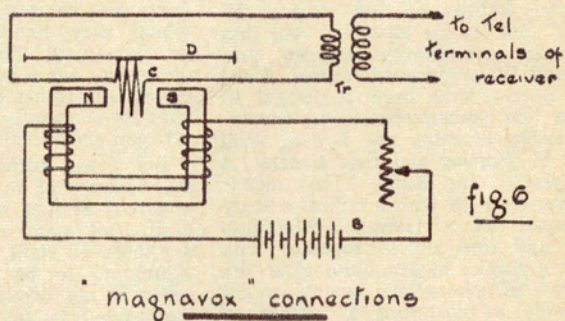
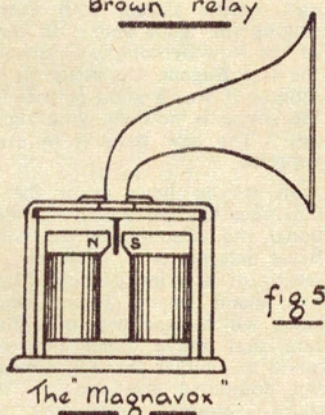
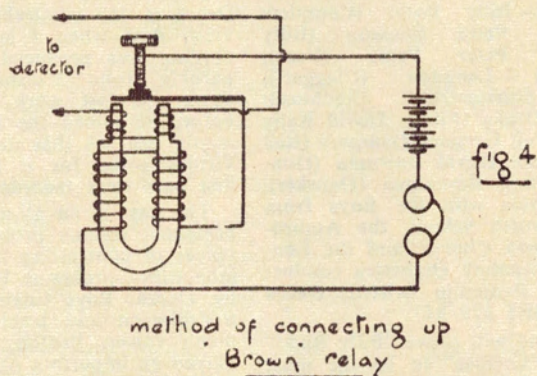
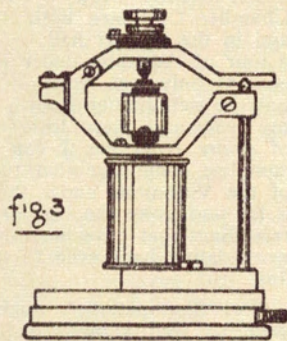
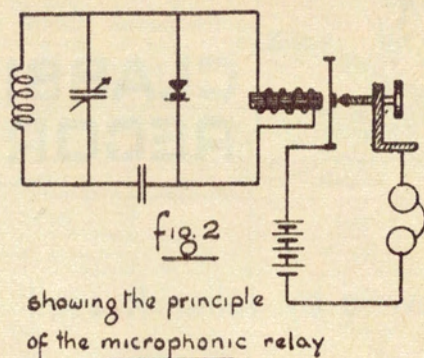
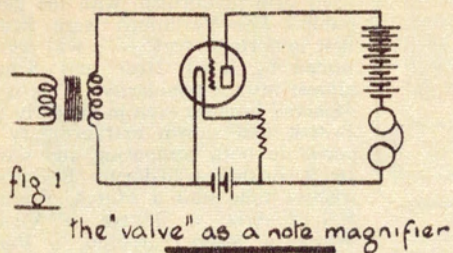

ly placed over the diaphragm and takes the place of the usual uncomfortable ear-pieces.

The "Magnavox" works on the principle that the magnetic field across the gap being constant, whenever a received current from the transformer passes through the windings of the small coil it is either attracted or repelled, depending upon the direction of the pulsating current. The movements of this coil are therefore transferred to the mica diaphragm and in turn converted to sound waves in the horn.

During the development of this apparatus an experimental instrument was placed on the chimney of the laboratory and connected with microphones and a phonograph. On clear evenings, songs and phonograph music, sung and played before the microphones within the building, could be heard by the whole population of the town, approximately 6,000, and on one of these occasions it is claimed

the voice and music were heard eight miles away. The slender tones of a single violin could be distinctly heard a mile away, while a piano solo resembled the chimes of Westminster Abbey played by the Colossus of Rhodes, truly a wonderful achievement. It is claimed, also, in connection with its use as a radio-signal magnifier used in conjunction with a valve amplifier, signals which are just audible can be eventually heard over a mile away, while wireless telephone conversations can be heard by assemblages of thousands of people and wireless music made loud enough to provide dance music for a hall full of dancers.

Added interest will also be given to this piece of apparatus when it is recalled how, last year, H.R.H. the Prince of Wales delivered an address at San Diego, Cal., U.S.A., to an audience of over 10,000 people during which his

(Continued on page 189)

# VOICE MAGNIFIERS

(Continued from page 115)

voice was distinctly heard in every corner of the vast auditorium, the "Magnavox" supplying the necessary voice magnification.

This article would be incomplete without reference to the "Baldwin" amplifying telephones. These receivers have come into considerable use since their inception, particularly for wireless purposes, as it is claimed that the incoming signal is magnified eight or nine times. A glance at the diagram, figure 8, will give an idea of the principle of its working, though for the sake of clearness the shape shown in the drawing has deviated somewhat from the actual instrument, mainly due to constructional details necessary in order to adapt such an arrangement into the size of an ordinary telephone receiver case.

As shown, it comprises a steel permanent magnet (M) with soft iron pole-pieces (C) of the shape illustrated, between which is placed the receiver winding, generally of high resistance, and a light soft-iron armature (A) pivoted at its centre. One end of this armature is left free, while to the other is secured a piece of stiff wire (L), the opposite end of which is secured to the centre of a diaphragm of selected mica.

The extreme sensitiveness of the receiver is mainly due to the fact that until signals are being received the armature (A) is under no magnetic strain, thus producing a greater diaphragm movement, and again, the armature is acted upon at both ends on account of the divided flux due to the design of the pole-pieces.

Thus, the deflection for a given current is correspondingly increased. ■