

HANDY CIRCUIT for CHECKING PHONO PREAMPS and FM TUNERS

Low-Cost pre-emphasis network simplifies frequency response tests.

THIS circuit, (Fig. 1) makes it easy to perform frequency response tests on phono preamplifiers and FM tuners. Previously, such tests were very difficult because of built-in de-emphasis characteristics. Depending on the tolerance of the parts used, the circuit can be assembled for about \$25, and will adhere fairly closely to the RIAA and FM pre-emphasis characteristics.

Pre-emphasis is a system of noise reduction often used in communications

equipment. Since most noise that creeps into high-fidelity circuits is high frequency in nature, the signal highs are boosted in strength before transmission or recording. Along the way (before "playback"), this noise joins up with the signal. However, if the overall level of the highs is reduced in the receiver (or preamp), the flat frequency response at the signal source will be obtained, along with an improved S/N ratio. This occurs because the high-frequency noise is dramatically attenuated.

FM and Disc Characteristics. The combination of pre-emphasis and de-emphasis appears in FM and recorded disc media. The pre-emphasis characteristics are easily synthesized using passive RC networks. These are preceded and followed by op amps giving gain or isolation.

Placing switch *S1* in the FM position will feed the input signal for jack *J1* to the noninverting input of amplifier *A1*, an op amp. (To reduce parts count, 747 op amps, which are two 741's in one pack-

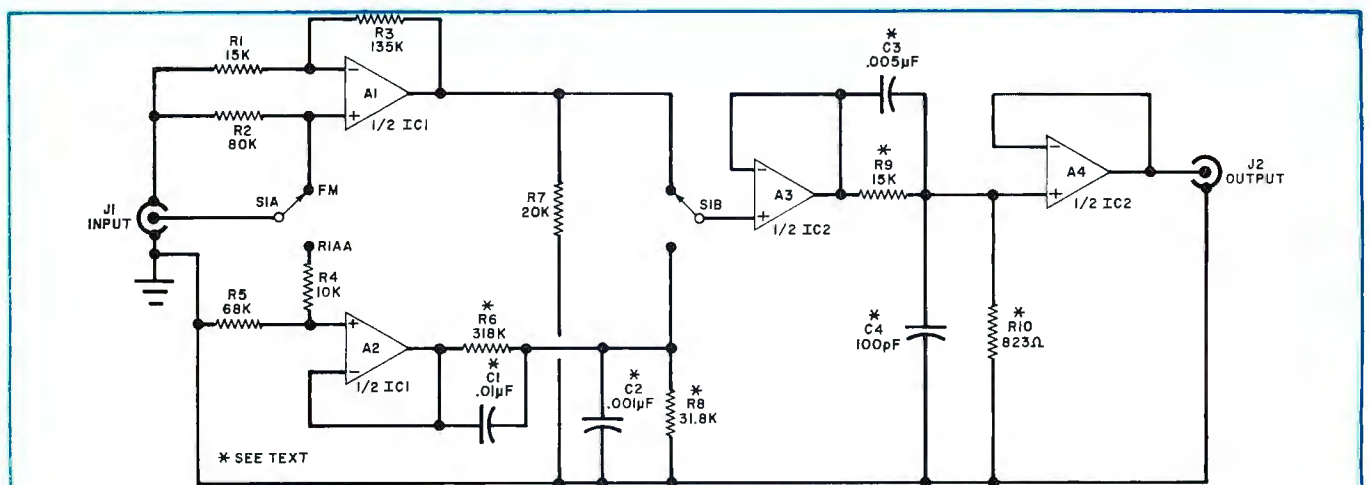

Fig. 1. Passive RC networks provide desired time constants. Op amps yield isolation and/or gain.

PARTS LIST

- C1—0.01- μ F capacitor* (polystyrene, mica, ceramic, or Mylar)
- C2—0.001- μ F capacitor* (polystyrene, mica, ceramic, or Mylar)
- C3—0.005- μ F capacitor* (polystyrene, mica, ceramic, or Mylar)
- C4—100-pF capacitor* (polystyrene, mica, ceramic, or Mylar)

- IC1, IC2—747 dual op amps
- J1, J2—RCA phono jacks
- Following resistors are 1/2-watt.
- R1—15,000-ohm resistor*
- R2—80,000-ohm resistor*
- R3—135,000-ohm resistor*
- R4—10,000-ohm 5% resistor
- R5—68,000-ohm 5% resistor

- R6—318,000-ohm resistor*
- R7—20,000-ohm 5% resistor
- R8—31,800-ohm resistor*
- R9—15,000-ohm resistor*
- R10—823-ohm resistor*
- S1—Dpdt switch
- *See Text

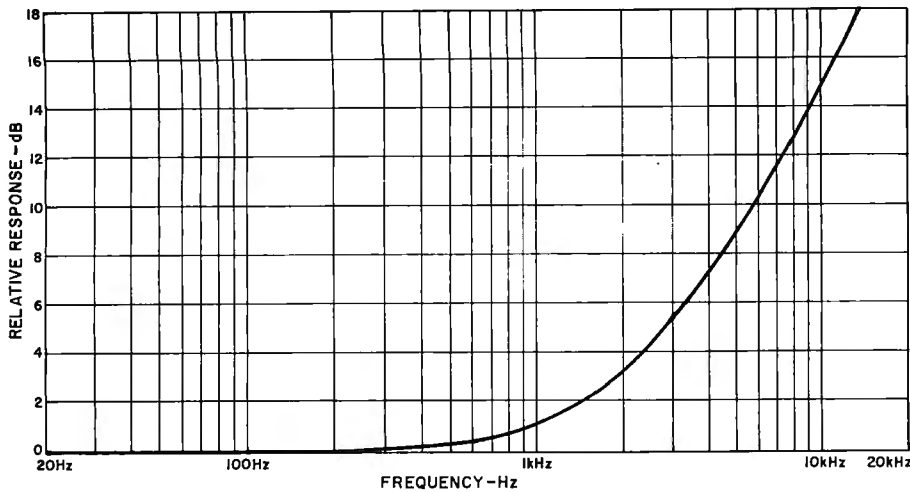

Fig. 2. FM 75-microsecond pre-emphasis curve. High frequencies are boosted in strength to improve S/N.

age, will be used.) This stage provides 20 dB of gain. Its output drives A3, a voltage follower used as a buffer. Resistor R9 and capacitor C3 provide the desired 75- μ s pre-emphasis time constant ($T=RC$). Very high frequencies are rolled off by the R10-C4 combination. Another voltage follower, A4, adds unity gain and isolation between the RC network and the output. The circuit's frequency response will be a good approximation of the 75- μ s pre-emphasis curve shown in Fig. 2.

When S1 is in the RIAA position, the input signal is applied to A2, an op amp buffer. This, in turn, drives the RC network consisting of R6, R8, C1 and C2.

The RIAA time constants of 3180 and 318 μ s are provided by this network. The signal is then routed through A3 and the 75- μ s RC network. Voltage follower A4 isolates the sensitive RC combination from the output. The prototype's RIAA pre-emphasis curve of amplitude versus frequency is shown in Fig. 3.

Construction. For the most part, construction of the pre-emphasis network is not critical. Either pc or perforated board can be used. One area is critical however—parts tolerance of the asterisked components in Fig. 1. To provide the desired time constants, these values should be as close to the published val-

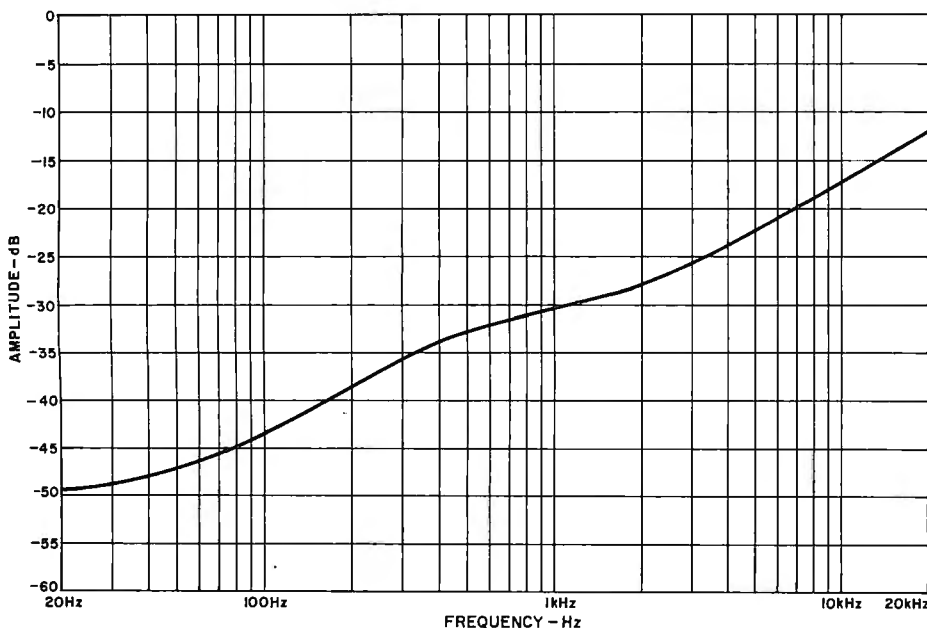

Fig. 3. RIAA pre-emphasis response. The circuit produces a close approximation of the standard RIAA curve.

ues as possible. This does *not* mean that you'll have to spend lots of money for precision parts—assuming you're lucky enough to find a source. However, there's a much easier way. Buy lower-tolerance parts (say 5% resistors and caps) and use small trimmer (or padder) pots and capacitors. For example, several surplus dealers are offering high-quality rectangular pc trimmer pots for less than \$1 each. If they are available in the correct ranges, you can use them alone for the resistive components, after adjusting them with a quality digital or analog multimeter. Also, a regulated bipolar 15-V dc supply is required for best results.

Using the Pre-emphasis Network.

To test a phono preamp, connect a frequency-sweep function generator to the input of the pre-emphasis network. Then, connect the output of the pre-emphasis network to the phono input using a short patchcord. Monitor the preamp output on an oscilloscope. Connect the output to the vertical amplifier and the main sweep sawtooth output of the function generator to the horizontal amplifier. When the generator sweep range and the preamp circuitry are properly adjusted, you'll get a pictorial image of the preamp's "flat" response on the CRT.

For FM measurements, you can use one of two techniques. If you have an FM generator, connect the swept function generator's output to the modulation input of the FM generator through the FM pre-emphasis network. Then attach the FM output to the antenna terminals of the tuner, observing the output on the scope (using the vertical and horizontal amps as above).

If you don't have an FM generator, connect the function generator (through the pre-emphasis network) to the FM detector output—at the input of the tuner's de-emphasis network. You should then observe a flat response (up to 15 kHz) at the tuner output.

Signal Levels. The pre-emphasis network will provide 30 dB of attenuation at 1000 Hz in the RIAA mode and 5 dB in the FM mode. This allows the use of a high (line) level driving signal without additional padding. If 0-dB attenuation is desired, you can simply crank up the function generator output. Alternatively, you can use an op amp preamplifier at the INPUT jack with switchable gain—selecting the feedback resistor to provide 5 or 30 dB of gain for FM and RIAA, respectively. \diamond