

## Non-inverting microphone pre-amplifier circuit

### Design Goals

Input Pressure (Max)	Output Voltage (Max)	Supply		Frequency Response Deviation	
		V <sub>cc</sub>	V <sub>ee</sub>	@20Hz	@20kHz
100dB SPL (2 Pa)	1.228V <sub>rms</sub>	5V	0V	–0.5dB	–0.1dB

### Design Description

This circuit uses a non-inverting amplifier circuit configuration to amplify the microphone output signal. This circuit has very good magnitude flatness and exhibits minor frequency response deviations over the audio frequency range. The circuit is designed to be operated from a single 5V supply.

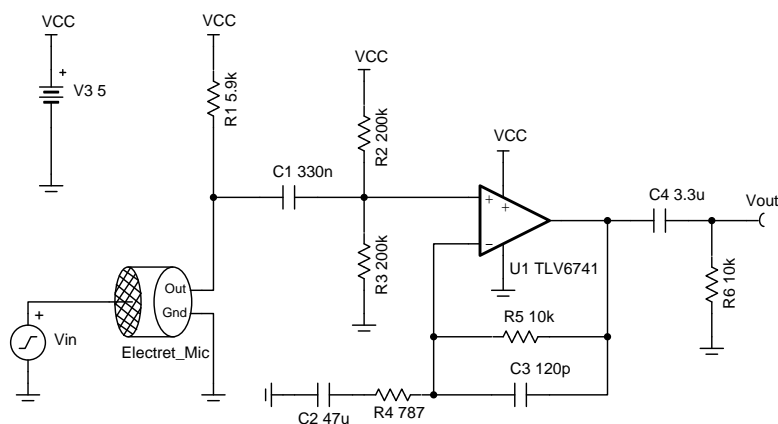

### Design Notes

1. Operate within the op amp linear output operating range, which is usually specified under the  $A_{OL}$  test conditions.
2. Use low-K capacitors (tantalum, C0G, and so forth) and thin film resistors help to decrease distortion.
3. Use a battery to power this circuit to eliminate distortion caused by switching power supplies.
4. Use low value resistors and low noise op amps for low noise designs.
5. The common mode voltage is equal to the DC bias voltage set using the resistor divider plus any variation caused by the microphone output voltage. For op amps with a complementary pair input stage it is recommended to keep the common mode voltage away from the cross over region to eliminate the possibility of cross over distortion.
6. Resistor  $R_1$  is used to bias the microphone internal JFET transistor to achieve the bias current specified by the microphone.
7. The equivalent input resistance is determined by  $R_1$ ,  $R_2$ ,  $R_3$ . Use large value resistors for  $R_2$  and  $R_3$  to increase the input resistance.
8. The voltage connected to  $R_1$  to bias the microphone does not have to be the same as the op amp supply voltage. Using a higher voltage supply for the microphone bias allows for a lower bias resistor value.

## Design Steps

This design procedure uses the microphone specifications provided in the following table.

Microphone Parameter	Value
Sensitivity @ 94dB SPL (1 Pa)	-35 ± 4 dBV
Current Consumption (Max)	0.5mA
Impedance	2.2kΩ
Standard Operating Voltage	2Vdc

- Convert the sensitivity to volts per Pascal.

$$10^{\frac{-35\text{dB}}{20}} = 17.78 \frac{\text{mV}}{\text{Pa}}$$

- Convert volts per Pascal to current per Pascal.

$$\frac{17.78 \frac{\text{mV}}{\text{Pa}}}{2.2\text{k}\Omega} = 8.083 \frac{\mu\text{A}}{\text{Pa}}$$

- Max output current occurs at max pressure 2Pa.

$$I_{\text{Max}} = 2\text{Pa} \times 8.083 \frac{\mu\text{A}}{\text{Pa}} = 16.166\mu\text{A}$$

- Calculate bias resistor. In the following equation, V<sub>mic</sub> is microphone standard operating voltage.

$$R_1 = \frac{V_{\text{cc}} - V_{\text{mic}}}{I_s} = \frac{5\text{V} - 2\text{V}}{0.5\text{mA}} = 6\text{k}\Omega \approx 5.9\text{k}\Omega \text{ (Standard Value)}$$

- Set the amplifier input common mode voltage to mid-supply voltage. The equivalent resistance of R<sub>2</sub> in parallel with R<sub>3</sub> should be 10 times larger than R<sub>1</sub> so that a majority of the microphone current flows through R<sub>1</sub>.

$$R_{\text{eq}} = R_2 \parallel R_3 > 10 \times R_1 = 100\text{k}\Omega$$

Choose R<sub>2</sub> = R<sub>3</sub> = 200kΩ

- Calculate the maximum input voltage.

$$R_{\text{in}} = R_1 \parallel R_{\text{eq}} = 5.9\text{k}\Omega \parallel 100\text{k}\Omega = 5.571\text{k}\Omega$$

$$V_{\text{in}} = I_{\text{max}} \times R_{\text{in}} = 16.166\mu\text{A} \times 5.571\text{k}\Omega = 90.067\text{mV}$$

- Calculate gain required to produce the largest output voltage swing.

$$\text{Gain} = \frac{V_{\text{outmax}}}{V_{\text{in}}} = \frac{1.228\text{V}}{90.067\text{mV}} = 13.634 \frac{\text{V}}{\text{V}}$$

- Calculate R<sub>4</sub> to set the gain calculated in step 7. Select feedback resistor R<sub>5</sub> as 10kΩ.

$$R_4 = \frac{R_5}{\text{Gain} - 1} = \frac{10\text{k}\Omega}{13.634 - 1} = 791\Omega \approx 787\Omega \text{ (Standard Values)}$$

The final gain of this circuit is:

$$\text{Gain} = 20 \log \frac{V_{\text{out}}}{V_{\text{in}}} = 20 \log \frac{16.166\mu\text{A} \times 5.571\text{k}\Omega \times \left(1 + \frac{10\text{k}\Omega}{787\Omega}\right)}{2\text{V}} = -4.191\text{dB}$$

- Calculate the corner frequency at low frequency according to the allowed deviation at 20 Hz. In the following equation, G<sub>pole1</sub> is the gain contributed by each pole at frequency "f". Note that you divide by three because there are three poles.

$$f_c = f \sqrt{\left(\frac{1}{G_{\text{pole1}}}\right)^2 - 1} = 20\text{Hz} \sqrt{\left(\frac{1}{10^{\frac{-0.5/3}{20}}}\right)^2 - 1} = 3.956\text{Hz}$$

- Calculate C<sub>1</sub> based on the cut off frequency calculated in step 9.

$$C_1 = \frac{1}{2\pi \times R_{\text{eq}} \times f_c} = \frac{1}{2\pi \times 100\text{k}\Omega \times 3.956\text{Hz}} = 0.402\mu\text{F} \approx 0.33\mu\text{F} \text{ (Standard Value)}$$

- Calculate C<sub>2</sub> based on the cut off frequency calculated in step 9.

$$C_2 = \frac{1}{2\pi \times R_4 \times f_c} = \frac{1}{2\pi \times 787\Omega \times 3.956\text{Hz}} = 51.121\mu\text{F} \approx 47\mu\text{F} \text{ (Standard Value)}$$

- Calculate the high frequency pole according to the allowed deviation at 20 kHz. In the following equation, G<sub>pole2</sub> is the gain contributed by each pole at frequency "f".

$$f_p = \frac{f}{\sqrt{\left(\frac{1}{G_{\text{pole2}}}\right)^2 - 1}} = \frac{20\text{kHz}}{\sqrt{\left(\frac{1}{10^{\frac{-0.1}{20}}}\right)^2 - 1}} = 131.044\text{kHz}$$

13. Calculate C3 to set the cut off frequency calculated in step 12.

$$C_3 = \frac{1}{2\pi \times R_5 \times f_p} = \frac{1}{2\pi \times 10k\Omega \times 131.044kHz} = 121.451pF \approx 120pF \text{ (Standard Value)}$$

14. Calculate the output capacitor, C<sub>4</sub>, based on the cut off frequency calculated in step 9. Assume the output load R<sub>6</sub> is 10kΩ.

$$C_4 = \frac{1}{2\pi \times R_6 \times f_c} = \frac{1}{2\pi \times 10k\Omega \times 3.956Hz} = 4.023\mu F \approx 3.3\mu F \text{ (Standard Value)}$$

## Design Simulations

### AC Simulation Results

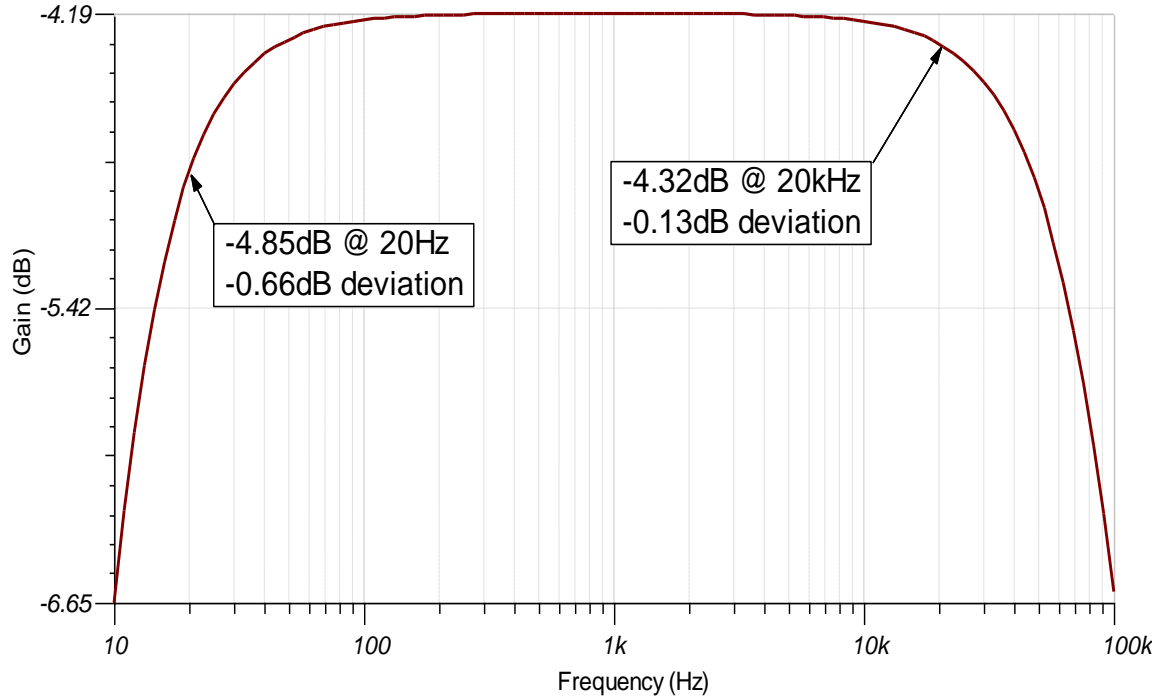

### Transient Simulation Results

The input voltage represents the SPL of an input signal to the microphone. A 1 V<sub>rms</sub> input signal represents 1 Pascal.

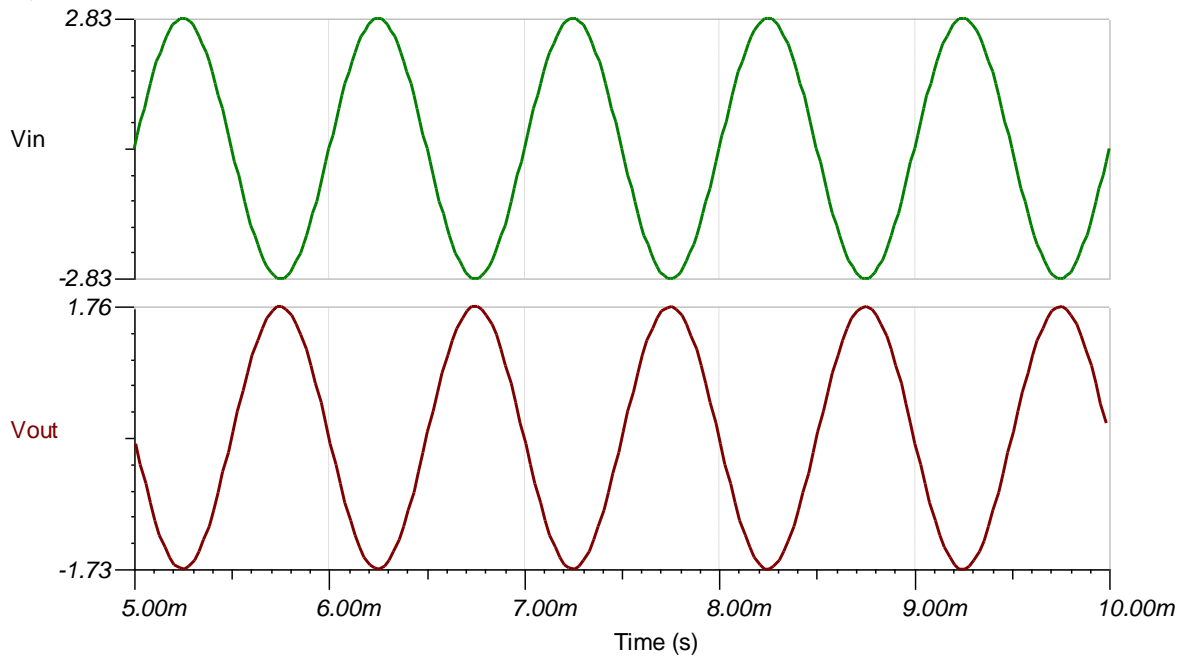

### Noise Simulation Results

The following simulation results show 22.39uVrms of noise at 22kHz. The noise is measured at a bandwidth of 22kHz to represent the measured noise using an audio analyzer with the bandwidth set to 22kHz.

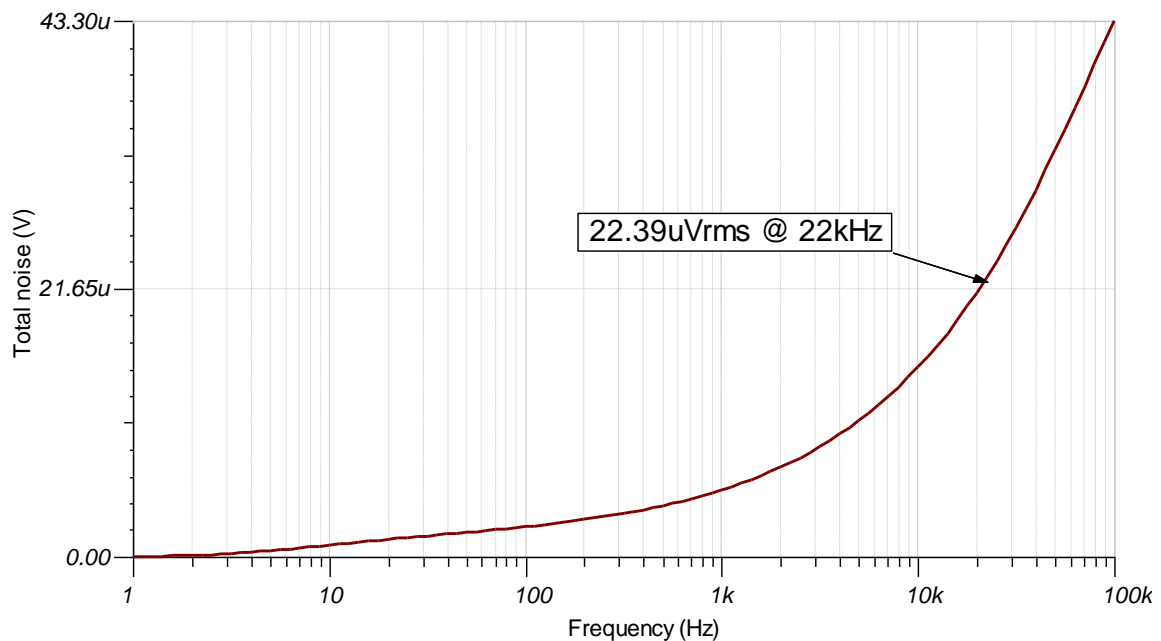

**References:**

1. [Analog Engineer's Circuit Cookbooks](#)
2. SPICE Simulation File [SBOC525](#)
3. TI Precision Designs [TIPD181](#)
4. [TI Precision Labs](#)

**Design Featured Op Amp**

<b>TLV6741</b>	
$V_{SS}$	1.8V to 5.5V
$V_{inCM}$	(Vee ) to (Vcc -1.2V)
$V_{out}$	Rail-to-rail
$V_{os}$	150 $\mu$ V
$I_q$	890 $\mu$ A/Ch
$I_b$	10pA
<b>UGBW</b>	10MHz
<b>SR</b>	4.75V/ $\mu$ s
<b>#Channels</b>	1
<a href="http://www.ti.com/product/tlv6741">www.ti.com/product/tlv6741</a>	

**Design Alternate Op Amp**

<b>OPA320</b>	
$V_{SS}$	1.8V to 5.5V
$V_{inCM}$	Rail-to-rail
$V_{out}$	Rail-to-rail
$V_{os}$	40 $\mu$ V
$I_q$	1.5mA/Ch
$I_b$	0.2pA
<b>UGBW</b>	20MHz
<b>SR</b>	10V/ $\mu$ s
<b>#Channels</b>	1, 2
<a href="http://www.ti.com/product/opa320">www.ti.com/product/opa320</a>	