

Description

The THAT 1510/1512 Demo Board is a self-contained circuit board that simplifies the evaluation of the THAT1510 and THAT1512. Completely assembled and tested, this system comes with XLR connectors for signal input and output, and 3 pin headers for standard and phantom power.

J1 is a Female XLR connector that accepts a balanced (or unbalanced) input signal, while P1, a male XLR connector, is connected for an unbalanced output. An external $\pm 15V$ power supply for the IC should be connected via header P3, along with an external +48V phantom power supply connected via header P2.

C5, C6, and C10 shunt unwanted RFI currents to chassis ground. The "T" arrangement of these components minimizes CMRR degradation at higher frequencies resulting from any

mismatch between C5 and C6; (the shunt paths for each input share C10, and C10's contribution to the effective shunt impedance of each side dominates that of C5 and C6).

When phantom power is applied, there is the potential for the phantom power circuitry to attempt to take the IC's inputs above the rail and outside the common mode input range of the THAT 1510/1512. This demonstration system has phantom power soft start that remedies this situation. In this portion of the circuit, Q1 acts as an emitter follower, and the time constant of R6 and C12 determines the instantaneous rate at which the phantom power rises. D7 is included to keep the base-emitter junction of Q1 from being damaged by being reverse biased. When phantom power is disconnected, D1 also closes the path for the residual charge stored on C1 and C2 to discharge through R6 and R7.

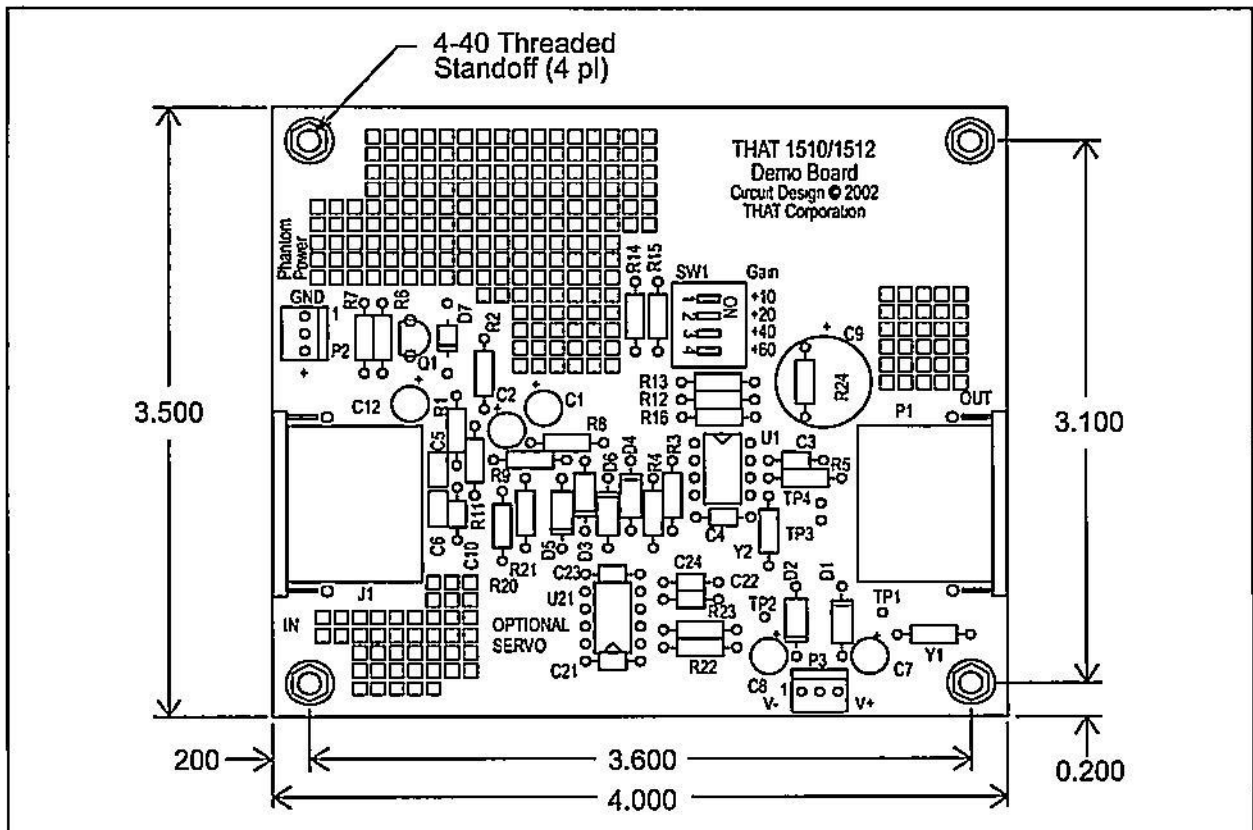

Figure 1 THAT 1510/12 Demonstration System Layout

All integrated circuit mic preamps are vulnerable to phantom power faults. There are two primary situations where these faults typically occur. In the first situation, the phantom power is applied but the input of the mic preamp is unconnected and floating. There will be +48V (relative to chassis ground) on C1 and C2. If the mic preamp is accidentally connected to a line driver output in another device, the positive sides of these capacitors are driven to the potential of the positive rail of the line driver. C1 and C2 will instantaneously behave as batteries, and attempt to drive the inputs of an unprotected mic preamp to some minus potential, typically -25 to -30 VDC. This will typically result in destructive currents running through parasitic junctions in the IC. The second scenario results when a mic preamp is connected through a patch bay. If phantom power is applied, and the tip-ring-sleeve connector is either inserted or removed, destructive currents will flow as the tip and ring of the connector are dragged across the contact which is intended to connect the sleeve to ground.

The THAT 1510/1512 demo board has protection diodes to address these scenarios. These diodes shunt potentially destructive currents to the rail before they can turn on junctions inside the IC. R8 and R9 limit the maximum current without severely affecting noise performance. Note that 1N4148s and the like will not work in this application, since they are not rated for the peak currents that can be expected. Likewise, back-to-back zeners won't work for the same reason. Either the currents are too high, or R8 and R9 must be increased to the point that their noise contribution becomes an issue. Using

larger zeners or tranzorbs will typically introduce distortion due to their non-linear input capacitance.

SW1 allows the gain of the THAT1510 or the THAT1512 to be switched in discrete steps of zero dB, 10dB, 20dB, 40dB, and 60dB. Values for a given gain resistor (shown in Table I of the schematic) were derived using the equation

$$A_V = 1 + \frac{10k\Omega}{R_G} \text{ for the THAT1510 and}$$

$$A_I = \frac{1}{2} + \frac{5k\Omega}{R_G} \text{ for the THAT1512}$$

There is a large electrolytic capacitor in series with the gain resistor network which helps avoid "thumps" when switching gain. This component is one of the largest components in the circuit, and in SMT implementations, it may take up as much as 40% of the board area. Additionally, it serves as a good antenna for picking up unwanted noise due to its size. We've included the circuitry (unpopulated) for an optional servo which can replace this capacitor. Table II of the schematic shows the parts required to implement the servo circuitry.

To ease prototyping of specific applications, spare circuit board area is perforated with plated through holes. This makes this board particularly useful for experimentation.

With a THAT 1510/1512 Demo Board and standard audio cables, an engineer can begin to evaluate the performance of the THAT 1510/1512 microphone preamplifiers in seconds, and start trying out new circuit ideas in minutes.

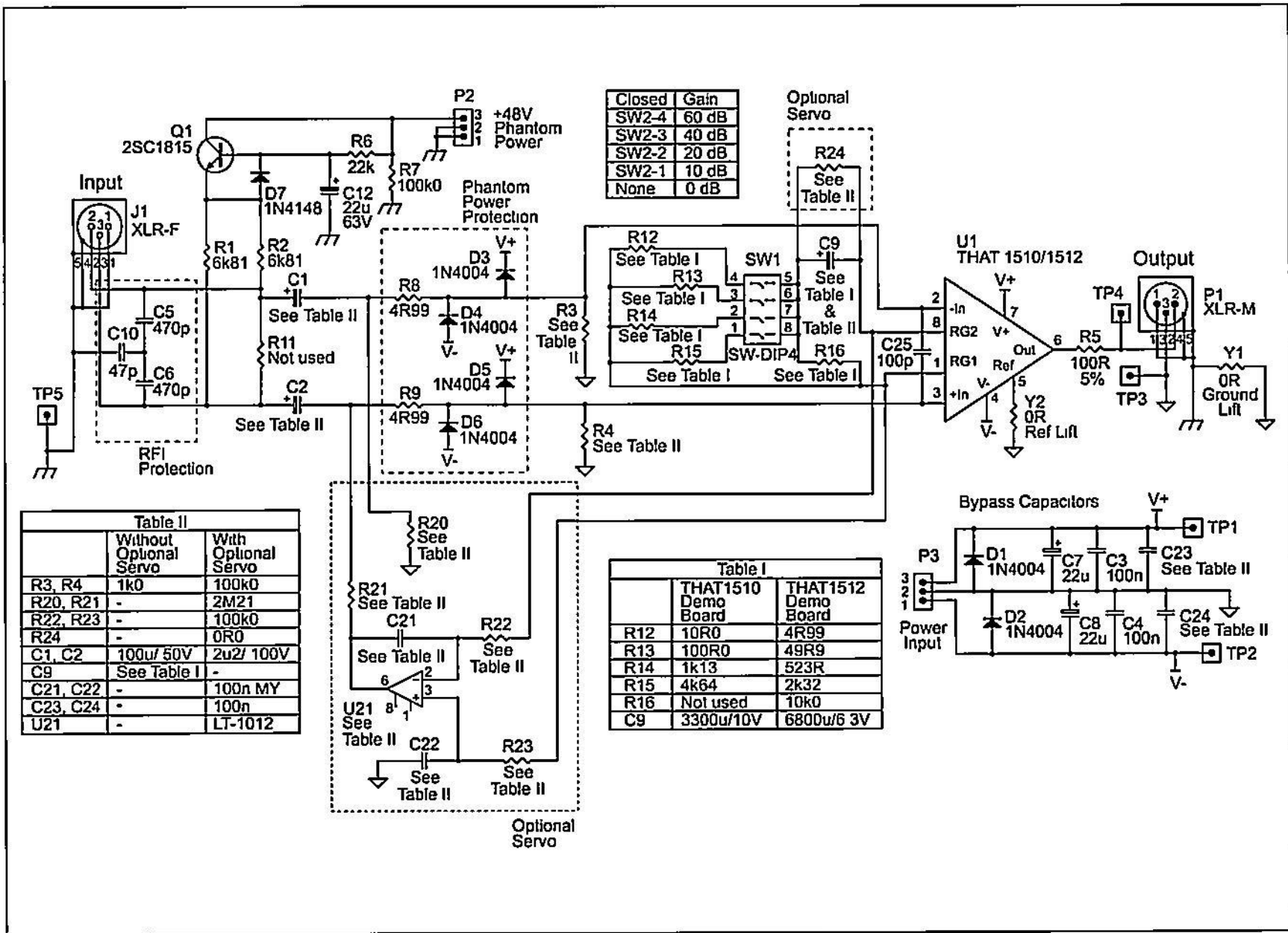

Figure 2 THAT 1510/1512 Demonstration System Schematic

THAT Corporation, 45 Summer Street, Milford, MA 01757-1656, USA
 Tel +1 508 478 9200, Fax +1 508 478 0990, Web www.thatcorp.com

Notes: