

SAPS-400 SMPSU for audio amps

£ 2.00 RLC Meter
can't beat that price

Thermo-Snake
128 thermometers on a string



More than audio

Looking at this month's magazine cover might suggest an overabundance of audio projects. The balance is more delicate however, although it can be argued that a fair number of articles are related in some way to audio.

The pages on the SAPS-400 describe a switch-mode power supply unit (SMPSU) specially designed for audio power amplifiers. This compact lightweight unit can supply a hefty 400 watts continuously. The main symmetrical output voltage is adjustable across a wide range and a separate $\pm 15\text{-V}$ auxiliary supply is incorporated for powering a preamplifier or similar. SAPS-400 at last enables high-power, high-end audio amps to be built where the enclosure is not 75% filled with bulky transformers and reservoir electrolytics.

SMPSUs are now used in lots of consumer and industrial equipment because of their small size and high efficiency. Still, many designers hate them for their design complexity and non-standard parts. Typically, the solution in these cases is to use a drop-in supply. Our theoretical backgrounder on SMPSU design on page 40 goes to show that things might be less complex than you think.

Our bench test of nine soundcards is not about sound quality in the first place. Lots of electronics enthusiasts use the soundcard in their PC to do low-frequency measurements and for that it's essential to have a linear amplitude response and a known-good frequency characteristic. That's why we did extensive measurements on the technical specs for these soundcards.

A handy application of the soundcard is described in the article '2-pound RLC Meter'. In it we show how an exquisite RLC meter can be built using no more than your PC, the soundcard, three components and a little Java program — very useful.

Happy reading!

Jan Buiting
Editor



SCORE: 7.5

A comparative

The quality of A/D and D/A converters makes it quite tempting to use a sound card for audio equipment measurements, especially as it fits quite nicely in the Windows environment. However, it takes more than good converters to make a good

26 SAPS-400

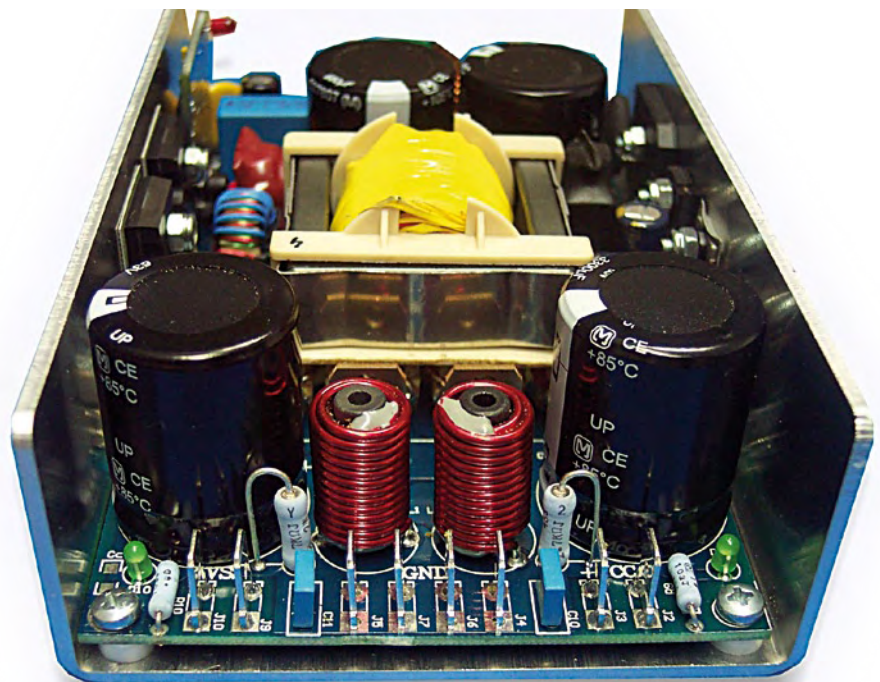

With the SAPS-400 we offer a powerful, adjustable symmetrical supply that's ideal for lightweight audio power amplifiers and happily sits in less than a quarter of the space taken by a comparable supply of conventional design.

SAPS-400

a 'powerhouse' switch-mode supply for audio amps

EXCLUSIVE
FROM ELEKTOR!
READY-BUILT MODULE
£ 159.-
WWW.ELEKTOR.COM

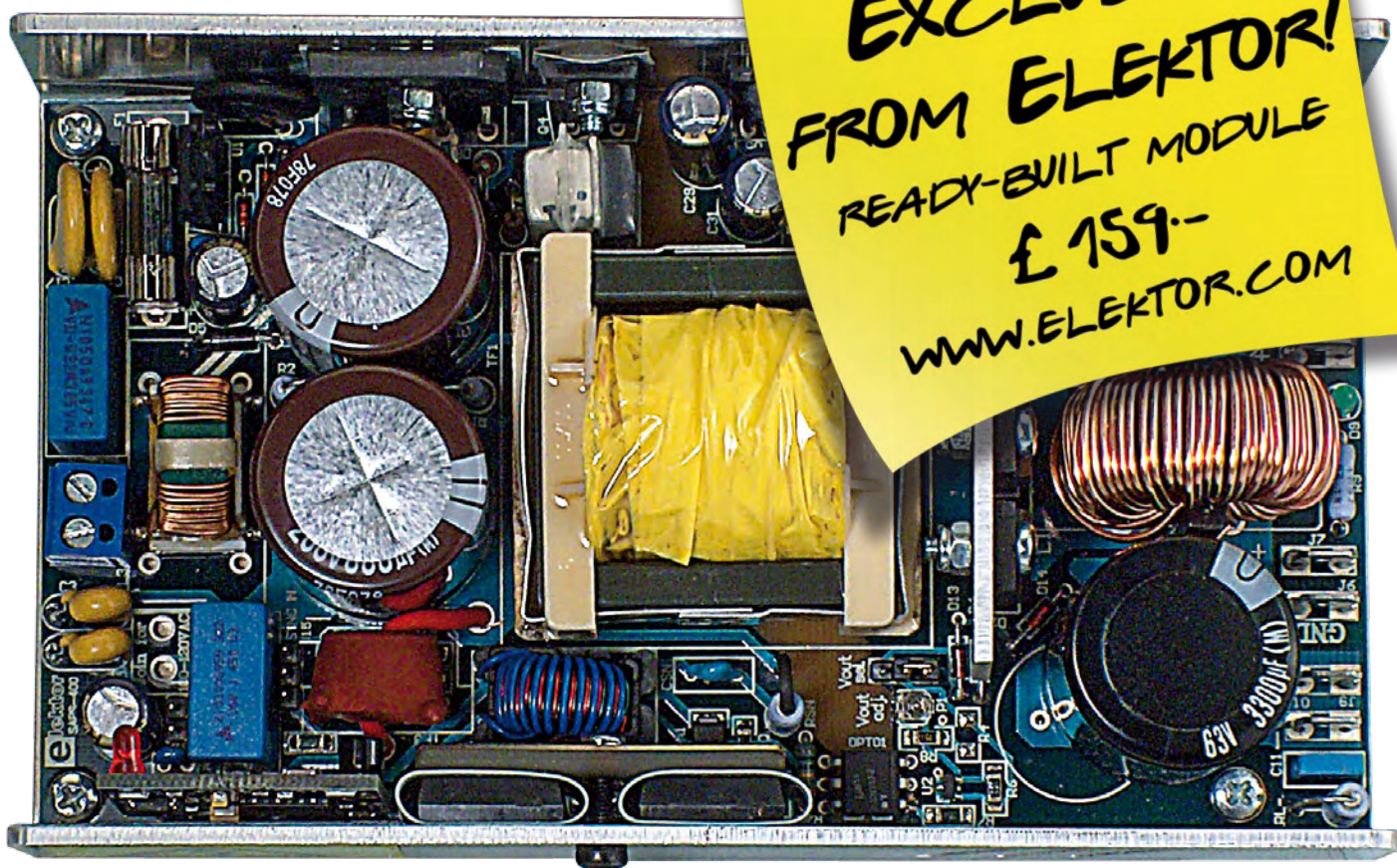

Sergio Sánchez Moreno (Coldamp, Spain)

The switch-mode power supply unit (SMPSU) is renowned for its efficiency but notorious for its design complexity, compared with its predecessor the linear supply. With the SAPS-400 we offer a powerful, adjustable symmetrical supply that's ideal for lightweight audio power amplifiers and happily sits in less than a quarter of the space taken by a comparable supply of conventional design.

In a fit of curiosity, if you open a piece of mains-powered modern electronic equipment, you will almost certainly find that it contains a switch-mode power supply unit (SMPSU). PCs, lap-

tops, TVs, DVD players, set-top boxes, etc. routinely rely on this kind of power source for many reasons: low cost, high efficiency, low weight and small size are the main ones.

However when you look inside an audio amplifier, you will probably find a linear power supply unit (PSU), based on a large and heavy transformer (very often not as large as it should be to

match the power rating of the amplifier!). There seems to be a traditional belief that switching power supplies (that do not operate at 50/60 Hz but at a much higher frequency, from 30 to 200 kHz, typically) are too noisy for those cherished amplifiers to produce a clean output, or that they don't behave correctly with wide-range dynamic signals, such as audio. A question arises here... then, why do you find switching PSUs in top-range high quality DVD players for example, that are very often the source of signal for our audio chains? In this case, things are even more critical, as all the signals involved have low amplitude and high impedance, hence in principle are more sensitive to perturbations.

Motivation

However, some time ago the ideas arose that a switching PSU would be very useful and advantageous for powering medium to high power audio amplifiers, obviating the need for that enormous (toroidal) transformers commonly used so far. As an example, a typical Class-AB 400+400 W amplifier uses (or should use) a toroidal transformer of around 1.2 kVA that weighs nearly 7 kg, without taking into account the rest of supply components (the reservoir capacitors will be big, too!).

Some market research was done looking for suitable commercial switching PSUs, but the disappointing outcome was that the typical voltages needed (symmetrical rails in the range from ± 30 V to ± 100 V, with auxiliary smaller outputs) were not available, forcing the designer to use two units in series to get both rails, but within this range, only 48 V ($\pm 10\%$) is available, as it is commonly used for communications equipment. Even in that case, the rails showed a lot of noise and were not powerful enough to cope with the amplifier's dynamic current demand, leading to audible noise and poor bass response mainly, not mentioning the cost issue.

So finally it was decided that it was time to try and design a PSU, keeping in mind all the special requirements of an audio amplifier from the start: it should be capable of producing clean supply rail(s) with low noise, low ripple and regulate tightly even at high current demands. However, at the same time it must be able to operate efficiently and quietly at very low current demands, when there is low or no

Specifications

- 400 W continuous
- Symmetrical output voltage, adjustable between 35 V and 60 V
- Compatible with 100-120 and 200-240 VAC (50-60 Hz) line voltage.
- Auxiliary voltage 15 V symmetrical, 500 mA
- Short-circuit resistant
- Efficiency: 92%
- Dimensions just 90 x 150 x 40 mm
- Weight: 450 g

input signal. These requirements are often somewhat conflicting, requiring that the PSU operates correctly both in continuous and discontinuous modes (see the SMPSU theory article elsewhere in this issue) but it can definitely be done, and the PSU we present here has indeed demonstrated that a switching PSU for amplifiers are not only feasible, but also offers important advantages over standard linear supplies, not only in terms of weight, size or cost, but also in sound quality!

General description

The presented PSU offers an adjustable dual output from ± 35 V to ± 60 V with up to 400 W continuous power capability (up to 800 W music power), an efficiency above 92% for an input voltage range from 100 to 120 and 200 to 240 VAC. It is short-circuit protected and features an inrush current limiter, auxiliary isolated ± 15 V at 500 mA aux. output, and EMI filtering (ElectroMagnetic Interference). SAPS-400 provides a clean and powerful sound with conventional Class-A, A/AB and AB amplifiers and also with more modern Class-D output stages.

SAPS-400's has a modest size of just 90x150x40mm, allowing it to be fitted inside 1-U 19-inch racks, and weighs around 450 g. It substitutes and even outperforms a complete linear PSU of at least 10 times its weight, 4 times its volume, and almost twice its cost.

The possible topologies to choose from are not that many, and not essentially different to the ones used for 'general-purpose' SMPSU. The PSU **must** be isolated for obvious safety reasons. Also, given the power level we are aiming to achieve (around 400 W), common sense and experience tell us that the choice is a half-bridge AC/DC converter. This is, indeed, the same topology used in almost every PC PSU, but the main differences are in the transform-

er, secondary circuit, control and feedback design.

Note that we are now talking about feedback: linear PSUs for amplifiers usually don't have any feedback. Due to the power level involved, designers usually don't even include linear regulators for stabilisation of the rails, so these tend to sag quite badly under load, unless vast amounts of reservoir capacitance are provided as the DC filter. Even in that case, any line voltage variation will produce the same percent of variation in the DC rails, causing a change in the amplifier's characteristics (power rating, mainly) when you plug it in in places with different line voltages.

On the other hand, the circuit we propose employs a feedback scheme to measure the output and compensate for line and load variations to provide as rigid as possible an output voltage, regardless (within limits!) of the line voltage and load variation. SAPS-400 can provide an output that is constant within 3-5% from no-load conditions to rated full DC load. Based on lab tests, this definitely translates in a cleaner sound, with deeper and tighter bass, as the PSU contributes significantly to have a low amplifier output impedance Z_{out} , resulting in higher damping factor ($DF = Z_{Load}/Z_{out}$), and hence more control of the cone excursion of the woofer.

Building blocks

Now, we will start describing the circuit. You can find the block diagram in **Figure 1**.

The basic operation is that of the half-bridge converter: once the AC voltage reaches the circuitry, it is filtered, fed through some protection circuits, and rectified by a diode bridge. Then, the output is smoothed by a capacitor bank, so we now have a high-voltage DC bus.

This DC bus is split, generating a mid point $V_{bus}/2$, and switched by means of two MOSFET transistors through a high-frequency transformer. It has two main secondaries, plus two smaller ones. Due to its turns ratio, the two main secondaries produce a waveform that is equal to the primary voltage multiplied by the turns ratio and also depends on the duty cycle ($V_{out} \sim V_{in} \cdot D \cdot N_{sec}/N_{pri}$). The output of the secondaries (that are joined in a centre point that will become the amplifier's ground reference) is full-wave rectified and filtered by an LC network, then producing two symmetric DC voltage rails. The total DC voltage is sensed by a feedback network that includes an adjustable voltage reference, and optically coupled to the control circuit, that adjusts the duty cycle of both MOSFET

There is also another small winding that is half-wave rectified providing a symmetric and isolated $\pm 15\text{ V}$ output, with a maximum current of 500 mA, very useful for preamplifiers, crossovers, controllers, etc.

Detailed description: input

The full schematic of SAPS-400 is shown in **Figure 2**. The mains input, connected to J1, passes through the protective fuse F1, then goes to the EMI input filter, formed by a common mode choke, L3, and a capacitor network. This filter suppresses the greater part of the switching noise, preventing it to travel back to the line. It also reduces generated RF noise that may upset the operation of the PSU. Note that C14, C17 and C18 are 'Y2' and 'X2'

shunted to Earth, that you may possibly be touching. This way, electric shock is prevented even in case of component failure.

The component marked RT1 is a special NTC (negative temperature coefficient) resistor that has a moderate resistance at ambient temperature (around 10 ohms) which drops considerably when the temperature of the NTC increases. Its function is to limit high inrush current peaks caused mainly by the sudden charge of the large reservoir electrolytics when the PSU is switched on. Needless to say, this NTC must be rated for a large impulse energy and a proper continuous operating current, at least the maximum current expected at the input (worst case is up to 4 A with 100 VAC input). Once the PSU is working normally, the current

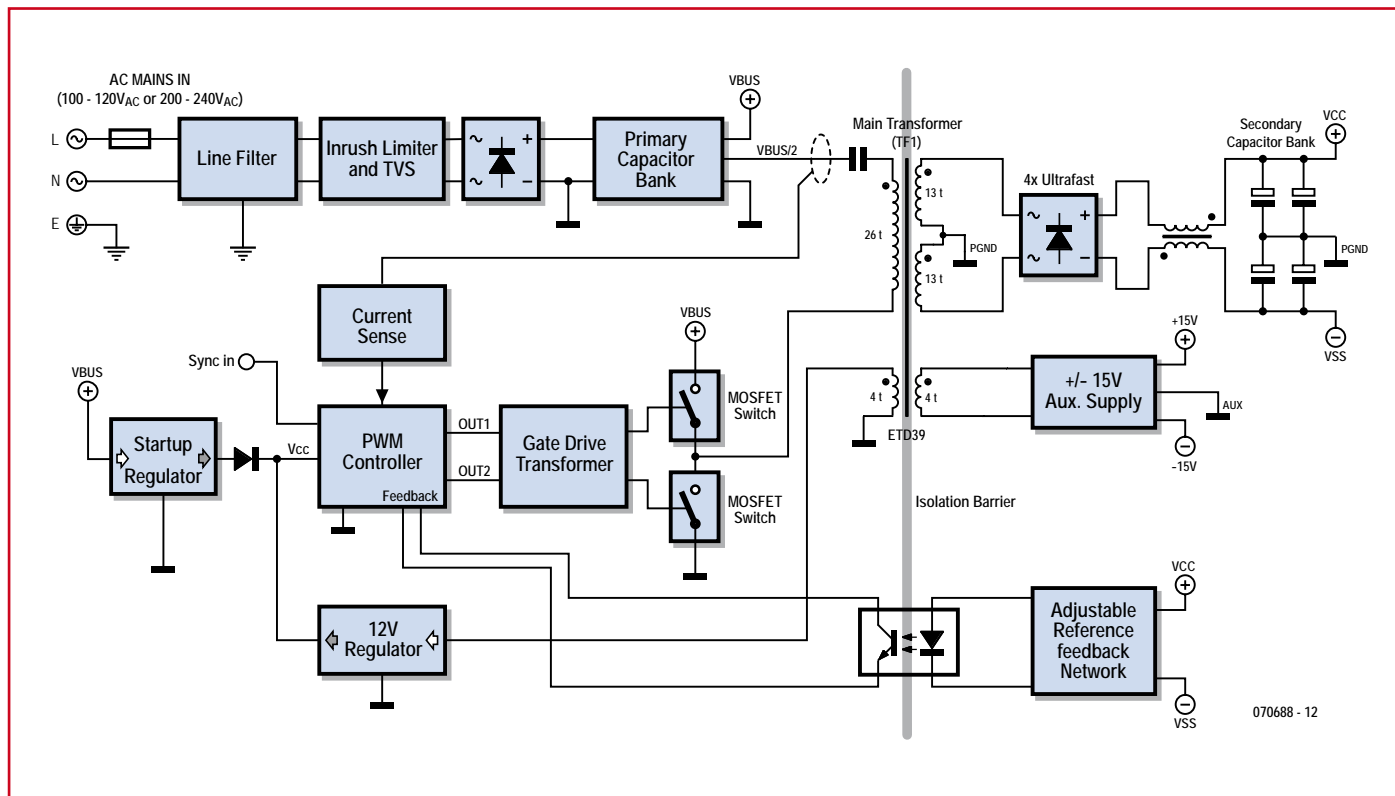

Figure 1. Block diagram of the SAPS-400. The bulk of work is done by the MOSFETs and transformer TF1; the control goes mainly on account of the PWM controller.

switches, in order to increase or decrease the output, thus implementing voltage regulation.

The control circuit needs some power (12 V at 80 mA max.) to operate (as it is in the primary side of the circuit, this power is isolated from the output for safety reasons). It gets its power from the startup circuit first, and once the PSU has cranked up, from a special housekeeping regulator.

class capacitors. Capacitors connected directly to the live mains voltage must have this certification; the one connected between Line and Neutral (C18) must go short-circuited in case of failure, so the fuse opens and everything is safe. It must be Y2 or X2 class (the latter being smaller for the same capacitance). On the other hand, the ones connected to Earth are Y2 types, and should 'fail open' so no current is

flowing through it makes it hotter and present a smaller impedance, thus its effect in the circuit is negligible once equilibrium is reached.

You can also find a transient voltage suppressor (TVS1). Its function is to cut any voltages above its rated voltage (and thus absorb lightning strikes and fast high voltage transients). If the input spike has enough amplitude or duration, it may eventually cause the

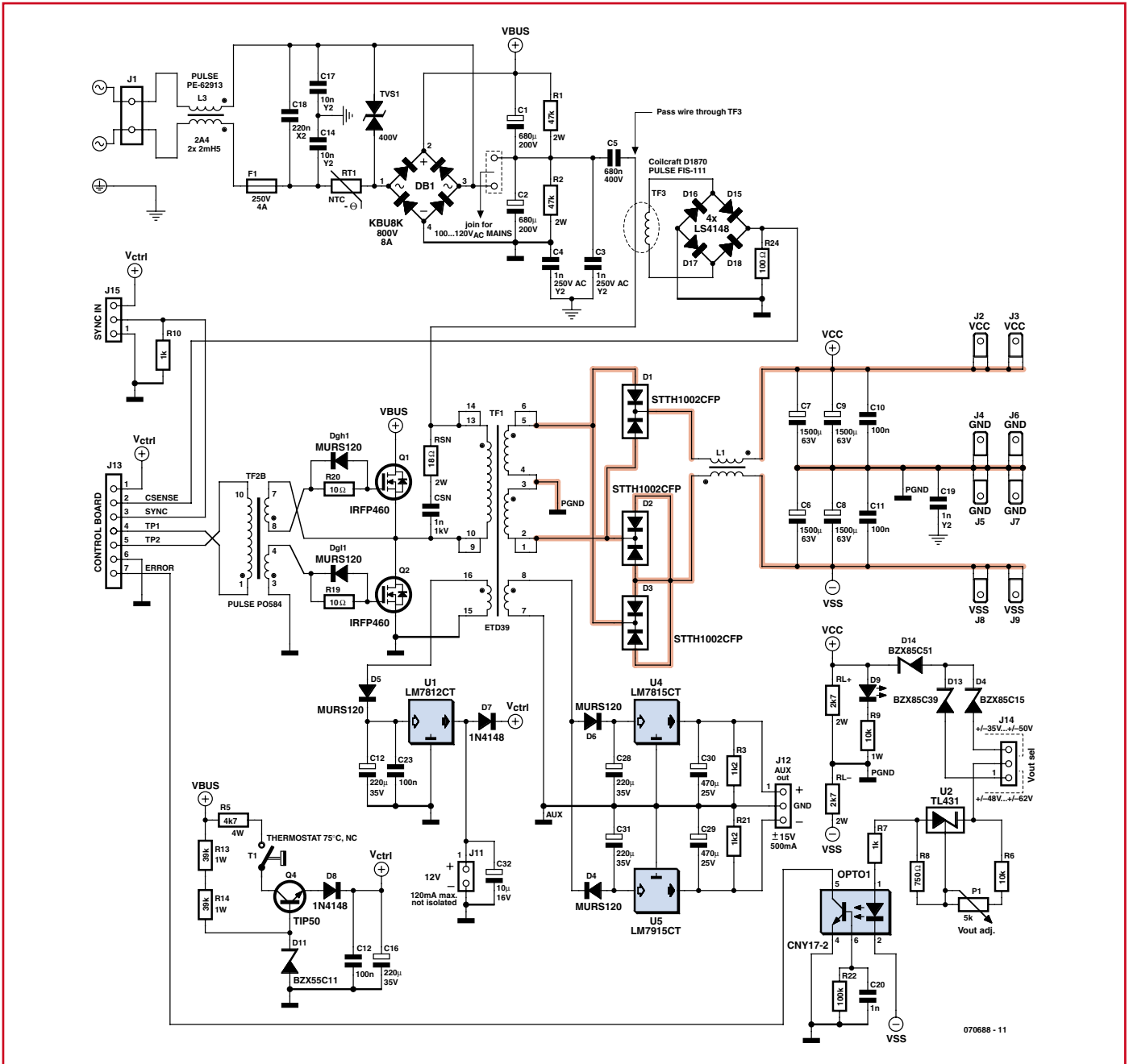

Figure 2. The circuit diagram shows the topology used, as well as all added controls and protections.

Advertisement



Die-cast aluminium,
metal and plastic
enclosures.

sales@hammond-
electronics.co.uk



www.hammondmfg.com/uk

fuse to blow, protecting the rest of the circuit. Note that this component is bidirectional; it clips positive and negative peaks whose instantaneous excursion exceeds the rated value.

Rectification and DC bus

After the filtering and protection circuitry, the AC signal is rectified by a diode bridge. Note that we are still operating at line frequency (50 or 60 Hz), so no need for fast diodes here! Only a part with a proper current and voltage rating has to be selected. In this case, we use an 800 V/8 A bridge, that is quite oversized.

The DC output is filtered by C1 and C2. These capacitors are in series, creating a midpoint $V_{bus}/2$. Two bleeder resistors (R1, R2) help in creating exactly half the bus voltage. This is a common arrangement to ease the implementation of a 'voltage doubler', that allows us to use lower mains (100 to 120 VAC). When this mains range is used, a switch or wire must join one of the AC inputs of the bridge to $V_{bus}/2$, thus doubling the voltage on the bus (that would otherwise be only 140 to 170 VDC approx.). The points to join for 100-120 VAC mains are marked 'A' and 'B' on the PCB.

Note that the connection between A and B must not be made if the circuit is to operate from a mains voltage higher than 120 VAC. Erroneously doing so may end up with a bus voltage of up to $240\text{ V} \times 1.414 \times 2 = 678\text{ V}$ that would destroy the PSU.

So far, this is very similar to the secondary part of a linear PSU! We now have a bus DC voltage equal to the peak of the input waveform. If we assume that the AC input waveform is more or less sinusoidal, the DC voltage will be $\sqrt{2} = 1.414$ times the input RMS voltage: that is, for 230 VAC, we have around 325 VDC here! When loading increases, we will start to have the typical 100/120 Hz ripple here. The capacitor's size is designed so this ripple is under $30 V_{pp}$ or so at max. load. This will have little effect on the output, as it is regulated.

There is an important difference with regard to a conventional supply: the current involved in the primary side is much smaller for a given power than when rectifying in the secondary part, so bus capacitors are much smaller in

capacitance than in a linear PSU, and hence the peak charging currents are also smaller. These peaks are the main source for the annoying 100/120 Hz 'buzz' noises, that won't be a problem now.

Primary power stage

The main transformer, TF1, has a single primary that's AC coupled to half the bus voltage ($V_{bus}/2$) by means of coupling capacitor C5. The other leg is connected to a half-bridge formed by two MOSFET switches, Q1 and Q2, that al-

ing waveform that swings from $+V_{bus}/2$ to $-V_{bus}/2$). With this in mind, and reviewing the power capability we need, we can now start to choose a suitable core and bobbin. RF transformers for half-bridge converters are usually made with ferrite cores, and usually have no gap between both halves, as they are not required to store energy, as happens in flyback converters (limited to around 100 W and widely used for small adapters, chargers or TV HV stages).

In this case, we have chosen an ETD39 core. It can be checked in some ref-



ternatively connect it to V_{bus} or 0 V. It's worth saying that the MOSFETs are driven by a gate drive transformer (TF2B) with two separate windings; each one connected between gate and source, plus a gate resistor. This gate resistor has a diode connected in anti-parallel to speed up turn-off of the MOSFETs and further prevent cross-conduction (both MOSFETs on at the same time, leading to a dangerously large current). The primary of this transformer is driven by a high-current driver IC in the control board.

The main transformer sees no DC component (due to C5, that must be large enough to avoid excessive droop during the flat top and bottom of the square waveform), but an AC switch-

erences that its size (related to the $W_a A_c$ parameter, where W_a is available core window area, A_c is effective core cross-sectional area) is enough for the 400 W we are aiming at, at a frequency $> 80\text{ kHz}$ in a half-bridge topology. Details on the calculations on the transformer are in the textbox. We proceed in the same way to calculate the number of turns for the housekeeping and aux. secondaries, keeping in mind the headroom required for the linear regulators (we design for an output of 18 V with the min. input, leading to four turns).

The physical design of the transformer is critical for the performance of the converter, and some guidelines are exposed here:

- We must have as low leakage induct-

ance as possible. That means as tight as possible coupling between primary and secondary and between windings and the core. To help this, we have split the primary in two parts, 13 turns each, and the main secondary is tightly wound between them. This is called 'sandwich winding'.

- The wire cross-sectional area must be enough to have low resistance and produce low copper losses at the power level we want. But we cannot simply use as thick as possible wire: *skin effect* is an effect that makes current flow only in the surface of the entire conductor when frequency goes higher. At 85 kHz, it is pointless to use wires above 1 mm dia. or so, so we will use two wires in parallel for the primaries and also for the main secondaries.

- Isolation and safety is a main concern. Under no circumstance may the primary and secondary wires be shorted. Moreover, a typically 3 kV voltage shouldn't produce an arc from one to another, that's why some distances and materials are defined. We use supplementary isolation (special triple insulated wire in the primary) and tubing in the ends so the proper creep distances and clearances are kept. Note that the primary and secondary pins are assigned to opposite ends of the coil former, so the PCB clearances can also be met (this PSU features 8 mm between primary and secondary, more than what regulation requires for this class of product).

- And... of course: we must be able to fit all the wires in the bobbin! This may seem trivial but it is not. This transformer has been tightly and tidily wound, otherwise it wouldn't fit.

There are many more considerations to be kept in mind during the design, such as Eddy currents, varnishing to avoid vibration or mechanical noises, etc, but these fall out of the scope of this description.

Secondary sub-circuit

Regarding the secondary part of the circuit, full-wave rectification has been used, with a central tap in the transformer that becomes the GND reference for the amplifier. Note that three dual ultrafast diodes have been used, as now we are rectifying a waveform of 85 kHz and standard-recovery diodes would have too high losses. It swings from up to $160 V_{pp}$, so we have selected 200 V diodes. The worst-case average current that will flow through each diode is

$$(P_{max} / 2) / 35 V = 5.8 A.$$

We have selected 10 A diodes. Following rectification, an LC filter is used. The coil has a function of storage of energy when there is no voltage switched to the transformer (when duty-cycle is below 50%), hence smoothing it with the aid of the capacitors, so it must have enough inductance. Typically used cores are made of ferrite or iron-powder.

We have wound both inductors on the same core (but with opposite directions as the voltages have opposite sign). This increases cross-regulation drastically (if they were not coupled, the voltage in one rail will drop and the other one will rise slightly if the current drawn is not balanced for both rails). Using a toroidal core also has the advantage of having a closed magnetic loop, thus providing little ra-

diated EMI.

The capacitor bank (also present in linear PSUs), is designed in a different way in switching PSUs: capacitors are refreshed at $2 f_{switch}$, which is far more than 100 Hz. This results in a much more constant output voltage (less voltage ripple) for a given total capacitance. For this reason, typical SMPSs can use output capacitors one or two orders of magnitude lower in capacitance than linear PSUs. However, for good reliability, the maximum ripple current rating must be high, and it is usually better to use two smaller caps in parallel than a single larger one, in terms of equivalent series resistance (that ultimately determines ripple current capability).

Additionally, despite the higher refresh rate of the capacitor bank, for audio amplifiers it is very important to have a great immediate energy reserve available right at the output terminals of the PSU. That's why we have chosen a relatively large capacitance, as opposed to other audio SMPS manufacturers. This also allows for a relatively slow but very stable feedback loop, while still keeping output quite stiff even with widely varying dynamic loads. This feedback loop is one of the keys in the design of a good (audio) SMPS.

Feedback, regulation and V_{out}

The total output voltage (from $+V_{CC}$ to $-V_{SS}$) is sensed with a resistor and selectable zener chain, plus an adjustable 5 V to 30 V stage built around the TL431 (U2), that sets a reference and drives an optocoupler photodiode. The phototransistor is connected to the control circuit, providing the necessary information so it can control the duty

Advertisement

ElmScan 5 ScanXL

ElmScan 5 is an advanced diagnostic package for use with EOBD compliant vehicles.

- Read and clear trouble codes
- Access up to 192 engine parameters
- Advanced Graphing and Data Logging
- Built-in Dyno and Drag Strip feature
- And much more...

For under £100!

www.scantool.net • sales@scantool.net



Order online today!

ScanTool.net
Inexpensive solutions for automotive diagnostics

Transformer calculations

For the calculation of the primary, we should use the fundamental equation of the transformer flux density, identified for a square wave-form that's related to the input voltage swing, frequency and section of the core:

$$\Delta B = E / (4 \times 10^{-8} \times A_e \times n_{pri} \times f_{switch})$$

or

$$n_{pri} = E / (\Delta B \times 4 \times 10^{-8} \times A_e \times f_{switch})$$

where

E = peak voltage in volts;

A_e = effective cross-sectional area in cm^2 ;

ΔB = the peak flux density in Gauss;

n_{pri} = the number of turns of the primary;

f_{switch} = the switching frequency in Hz.

We have to ensure the frequency is as close as possible to the desired value of 85 kHz. Too high a frequency, and you will have high core losses and switching losses in the MOSFET transistors. Too low a frequency, and you will have excessive flux density, also resulting in higher core losses and reduced power capability for a given core size, as well as bigger secondary-side components (inductors and capacitors). A conservative number for ΔB is around 1500 Gauss (0.15 Tesla) for Ferroxcube 3C90 material, at this frequency, producing around 2W core losses. Given that E is around 155V for 220V input (or 110VAC input using the proper voltage setting switch), this means that:

$$n_{pri} = 155 / (1500 \times 4 \times 10^{-8} \times 1.25 \times 85000)$$

$$= 24.31 \text{ turns}$$

$$\approx 25 \text{ turns.}$$

We will split the primary in two halves making it 13 turns each, for a total of 26 turns. This allows for a somewhat higher voltage input and still have a low enough flux density. (with these numbers ΔB will change from 1300 to 1538 gauss from 200-240 Vac, or 100-120 Vac).

Now, we have to calculate the secondary turns. In order to do that, we take the worst conditions to have some margin for the controller to be able to produce the maximum required output voltage. For the minimal nominal input voltage (say 200 VAC or 100 VAC with proper setting), we'll have a total of 280 V bus voltage. Assume that we need an output voltage of max. 60 V, and that the controller can put a max. duty cycle of $D = 45\%$ (it needs some dead-time). Then the required number of turns for each secondary will be:

$$V_{out} = V_{in} \times D \times N_{sec} / N_{pri}$$

$$= V_{in} \times D \times TR;$$

$$TR_{min} = V_{out-max} / (V_{in-min} \times D)$$

$$= 0.476$$

so

$$N_{sec} = 0.476 \times N_{pri}$$

$$= 0.476 \times 26$$

$$= 12.38 \text{ turns,}$$

we will round off to 13 turns per secondary.

(we should really add up for the bridge rectifier drop, (two diodes drop around 1.4 V), and for the output rectifier drop, (two fast diodes drop around 1 V), but that's negligible compared with the input and output voltages and we have already provided some margin.

cycle of the switching MOSFETs and readjust the output voltage as necessary so it is kept constant. Besides improving line and load regulation drastically, this also allows us to tailor the output voltage to our requirements. It can be adjusted in two ranges (selectable by means of jumper J14 and fine-tuned with the aid of potentiometer P1), between ± 35 V and ± 60 V.

The feedback network and its compensation are also critical and the key to success in the applicability of this PSU to audio. We have kept the control board confidential as it is a key part of our technology, but its basic function can be understood quite well as a PWM controller with a feedback input and some protections.

Startup and housekeeping circuits

The control board needs 10 to 15 V at 70 mA approx. There is a start-up regulator, built around Q4, connected as an emitter follower with an 11 V zener acting as the reference at its base. This puts out around 10.3 V from an input

between 300-350 V, with current limited by R5 to around 75 mA and connected through diode D8 to the control board supply. When the "housekeeping" supply (simply a 7812 12 V regulator fed from an auxiliary winding of the transformer) produces 12 V, D8 gets reverse-biased, so no current flows across Q4, and hence no dissipation is produced (apart from that of the biasing resistors of the base zener, R13 and R14).

If for some reason (failure, continued short-circuit, etc), the supply cannot start, R5 will warm-up until a thermally-coupled thermostat, T1, opens, preventing an overheating of the startup circuitry. If this happens, the supply won't start again until T1 closes; this may take several minutes, providing additional protection.

Overcurrent protection

The current that passes through the primary of TF1 is sensed by means of a high-frequency current sense transformer formed by a single turn primary

and a 100 turns secondary (actually resembling a wire crossing a toroidal coil). When rectified by a fast diode bridge (D15 to D18) and loaded by a 100 ohm resistor, it supplies 1 V/A, and goes to a comparator inside the control board that triggers the protection for 2 seconds when the sensed voltage is higher than approx. 4 V (4 A primary current, equivalent to around 400 W at 100 VAC). Note that the overcurrent limit is only approximate and its main purpose is to make the PSU short-circuit proof.

Auxiliary ± 15 V supply

The auxiliary and housekeeping supplies are very similar, comprising a secondary of the transformer (that puts out around 20 V, as its number of turns is 4), followed by a half-wave rectifier and linear post-regulators (7812 for the house-keeping and 7815/7915 for the aux. ± 15 V output).

If the aux. voltage needs to be extra-clean, an additional LC filter can be added at each output. A 10 to 100 μH

inductor in series with the output, followed by a capacitor of 1000 μF to ground will do the job.

Note that this auxiliary supply is protected against overcurrent and over-temperature by the 7x15 regulators themselves.

Also note that AuxGND reference is floating, so it is NOT connected to the main output GND (you can do this if you need it), nor to mains EARTH.

Installation, operation at low output voltage, etc.

The PSU should be mounted on a flat aluminum base (such as a case for an audio amplifier), unpainted and totally clean, for proper thermal transfer. There won't be any problems with audio use regarding to temperature, as the PSU is very efficient, but if continuous power capability tests are made, it is important to provide some forced cooling to the transformer and/or output diodes.

In order to fix the PSU to a chassis with base thickness W (mm), use four M3 screws with a length between $W+2$ and $W+4$ mm, so it gets secure enough but doesn't touch the PCB bottom.

The power dissipation of the entire PSU with no load connected is around 5.5 W, including the output bleeder resistors.

The chassis must always be connected to mains Earth, as is prescribed for Class-I equipment. Use one of the screws near the input connector for that purpose.

Although this PSU has been specifically designed for symmetric output, it can still be used for single output, by taking the negative terminal from $-V_{SS}$ and the positive from $+V_{CC}$ (GND



terminals must be left unconnected). This way, it can be adjusted from 70 V to 120 V.

If a lower voltage is required, please ask and we will help you determine if it is doable by simply changing one of the zener diodes or if some other part (such as the transformer itself) needs to be replaced.

Note that when working in the lower voltage ranges, the supply may produce some noise or even shutdown with no load, so additional bleeder resistors (there is one per rail, RL+ and RL-, already installed) may be need-

ed, calculated so they dissipate around 1.5 W max. (if the idle consumption of the circuit you are trying to feed is not enough).

When debugging such applications, it is useful to carefully connect two wires to header J8 and measure with a multimeter. **WARNING:** J8 is **not** isolated from the mains, so respect all electrical safety regulations. Connect the PSU with no load, and the voltage shouldn't go lower than 11 V. If so, it needs additional loading to keep operating.

(070688-1)

Advertisement

PCBs in 24 hours from £30.00

www.PCBTrain.com

Tel: 01635 40347
 Fax: 01635 36143
 e-mail: ctsults@newbury.econ.co.uk

Newbury Electronics Ltd
 Faraday Road, Newbury, Berkshire RG14 2AD
 www.newburyelectronics.co.uk

Approved ISO 9001

ANDRE LAMOTHE'S
XGAMESTATION
 LEARN STEP-BY-STEP HOW TO BUILD AND DESIGN YOUR OWN VIDEO GAME CONSOLE!

Design inspired by the Atari 800/2600, Sinclair ZX Spectrum, Apple II & Commodore 64!

Parallax SX Key Compatible!

INCLUDES:

- Tools, Demos & Utilities
- Great for Hobbyists AND Students!
- The Fun Way to Learn Embedded Systems!
- Fully Assembled XGS Micro Edition Unit!
- Complete Software Development KIT!
- eBook on Designing the XGS Console!
- Cables and Power Supply included!

www.XGAMESTATION.COM
 PH: 512.266.2399 | SUPPORT@NURVE.NET