

Hybrid Feedbacks for Power Amplifiers

HERBERT I. KEROES*

While feedback in most amplifiers is partially dependent on the load impedance, it is possible to eliminate this effect to a large extent with a claimed improvement in over-all performance.

MUCH INTEREST has been evinced in the system of Hybrid Feedback¹ as developed and used in the Acrosound Ultra-Linear II power amplifier. This system prevents interaction between feedback circuit and load; consequently its use results in a feedback system inherently more stable than the conventional systems now used.

The circuit has been developed from a consideration of the unique properties of the hybrid coil, a device long used in telephone communication to permit amplification in both directions on a telephone line without interaction. This property of circuit isolation is put to use in a similar manner between feedback and output circuits of an amplifier.

In its usual form, the hybrid coil is a three-winding transformer composed of a primary winding and two series-connected secondary windings of equal turns, and is shown diagrammatically at (A) in Fig. 1. If power is fed to the primary, it is divided equally between each load resistor, the two load resistors being of equal value. Another resistor is used to supply balance, and is shown connected between the junction of the two secondary windings. When all circuit resistors are chosen in a certain relationship, the circuit has several unique properties. A voltage placed in series with one load will not be reflected into the other load. A voltage placed in series with the balancing resistor will not appear in the primary winding of the transformer. The hybrid arrangement can then evidently be used to divide output voltage between load and feedback circuit without interaction. It would not be economical to divide power equally between load and feedback circuit, hence the section of the secondary which energizes the feedback circuit is composed of just enough turns to supply the requisite amount of feedback voltage.

The solution of a hybrid circuit where the secondary winding is comprised of

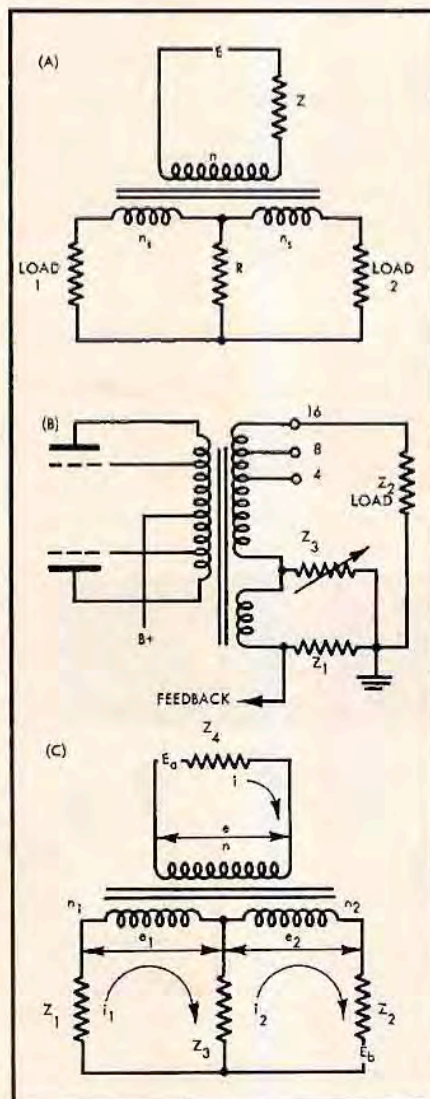

Fig. 1. Schematic of voltage and current relationships of the hybrid feedback arrangement.

two series-connected coils of equal turns is well known, and to be found in most standard texts. Where the secondaries are not of equal value, the solution is not easily available, and will be developed here. Another property of the hybrid circuit will also be developed—one which, to the best of the author's

knowledge, has not been previously disclosed.

As used in the Ultra-Linear II amplifier, the output transformer forms a hybrid coil, and the output circuit is shown at (B) in Fig. 1. The circuit of the output transformer alone is shown at (C). The voltages and impedances appearing across the various windings are as follows:

- E_0 The open-circuit plate-to-plate voltage of the output stage.
- E_b A voltage introduced into the load circuit to determine its effect on the feedback voltage. It may be an equivalent voltage generated by a change in load impedance (an assumption valid by the compensation theorem), or a back emf generated by the load.
- e The voltage across the primary winding of the transformer, composed of n turns.
- e_1 The voltage across the winding section composed of n_1 turns and which connects to the feedback circuit.
- e_2 The voltage across the winding section composed of n_2 turns and which connects to the load.
- Z_1 The feedback load impedance.
- Z_2 The output load impedance.
- Z_3 The balancing resistor.
- Z_4 The plate impedance of the output tubes.

We may write the equations for the voltage drops in each loop in terms of the loop currents and impedances by Kirchoff's law, and these give relationships (a), (b), and (c) below. Equations (d) and (e) are relationships that exist in any transformer, the sum of the ampere turns in each winding being zero, and the exact proportionality between the open circuit voltage and turns in each winding.

$$\begin{aligned} (a) \quad e &= E_0 - Z_4 i \\ (b) \quad e_1 &= Z_3 i_2 - (Z_1 + Z_3) i_1 \\ (c) \quad e_2 &= Z_2 i_2 - (Z_2 + Z_3) i_1 + E_b \\ (d) \quad n_1 i_1 + n_2 i_2 + n_3 i_3 &= 0 \\ (e) \quad \frac{e}{n} &= \frac{e_1}{n_1} = \frac{e_2}{n_2} \end{aligned}$$

The relationships of (a) and (c) may be substituted into (b), (c), and (d), to give the following three equations in which all currents are expressed in

* Aero Products Co., Philadelphia, Pa.
¹ Patent pending.



The Acrosound Ultra-Linear II amplifier discussed in this article.

terms of the applied voltages E_a and E_b . We may then solve these for the current in the feedback circuit, i_f , and the load current, i_2 .

$$\frac{n_1}{n} E_a = -(Z_1 + Z_2) i_1 + Z_3 i_2 + \frac{n_1}{n} Z_3 i_f$$

$$\frac{n_2}{n} E_a - E_b = Z_3 i_1 - (Z_2 + Z_3) i_2 + \frac{n_2}{n} Z_3 i_f$$

$$0 = n_1 i_1 + n_2 i_2 + n_3 i_f$$

The easiest method of solving these equations is to effect a solution by means of determinants. We obtain the following solutions for i_1 and i_2 .

$$D i_1 = \frac{n_1}{n} E_a \left[n(Z_2 + Z_3) + \frac{n_2^2}{n} Z_3 \right] +$$

$$\left(\frac{n_1}{n} E_a + E_b \right) \left(Z_3 n - \frac{n_1 n_2}{n} Z_3 \right)$$

$$D i_2 = \left(\frac{n_2}{n} E_a + E_b \right) \left[n(Z_1 + Z_3) + \frac{n_1^2}{n} Z_3 \right] + \frac{n_1}{n} E_a \left(Z_3 n - \frac{n_1 n_2}{n} Z_3 \right)$$

where

$$D = (Z_1 Z_2 + Z_2 Z_3 + Z_1 Z_3) n + \frac{n_1^2}{n} Z_1 Z_3 + \frac{n_2^2}{n} Z_2 Z_3 + \frac{Z_3 Z_4}{n} (n_1 + n_2)^2$$

If we now specify the condition that E_a is zero and E_b is not equal to zero, we find that i_1 is zero when Z_3 is equal in value to $n_1 n_2 Z_4 / n^2$. If then Z_3 is put at this value, a voltage injected into

the load circuit will not produce a current flow in the feedback circuit.

An impedance variation in the output circuit or a back emf generated by the load impedance will therefore not be transmitted into the feedback circuit. We shall now show that Z_3 may have any value from zero to infinity, and will not affect the proportionality of voltage induced by E_a in the feedback circuit, or change the phase of the induced voltage. To prove this we will

take the relationship $Z_3 = \frac{n_1 n_2 Z_4}{n^2}$ and transpose Z_3 and Z_2 . This becomes

$$Z_3 = \frac{Z_3 n^2}{n_1 n_2}$$

This is then inserted into the expression for i_1 . Also let $E_b = 0$.

$$i_1 = E_a \frac{1}{n_1 Z_2 + Z_3 (n_1 + n_2)} \frac{1}{Z_1 Z_2 + Z_2 Z_3 \left(1 + \frac{n_1}{n_2} \right) + Z_1 Z_3 \left(1 + \frac{n_2}{n_1} \right) + Z_3^2 \frac{(n_1 + n_2)^2}{n_1 n_2}}$$

The denominator may then be factored, and we find that one factor cancels with a similar expression in the numerator, giving the following solution for i_1 .

$$i_1 = E_a \frac{1}{\frac{Z_1}{n_1} + \frac{Z_2}{n_1} + \frac{Z_3}{n_2}}$$

Note that the only impedance terms in this expression are those of the resistor in the feedback circuit and the value of the balancing resistor. If these are set at a fixed value, the current that flows in the feedback circuit is constant, therefore the voltage developed across the feedback load is constant and independent of the value of the load impedance Z_2 .

The hybrid system is normally operated so that the nominal value of Z_2 produces a load current equal in value to i_1 . No current then flows in the balancing resistor Z_3 and it consumes no power. To find this relationship, E_b is put equal to zero and the expressions for i_1 and i_2 are equated. This gives the relationship $Z_1 / Z_2 = n_1 / n_2$. The turns ratio between the feedback and load sections of the secondary winding is adjusted to this value.

Finally, we note that if no current flows in the balancing resistor, the complete secondary of n_1 plus n_2 turns feeds a secondary impedance of Z_1 plus Z_2 ohms. The turns ratio between secondary and primary is then $n_2 / (n_1 + n_2)^2 = Z_3 / (Z_1 + Z_2)$. Z_3 is made equal to the correct plate-to-plate impedance of the output tubes and the turns ratio computed.

In the Ultra-Linear II amplifier, Z_3 is made variable. This provides a variable damping control which changes the ratio between voltage and current feedback. With the control adjusted to

(Continued on page 51)

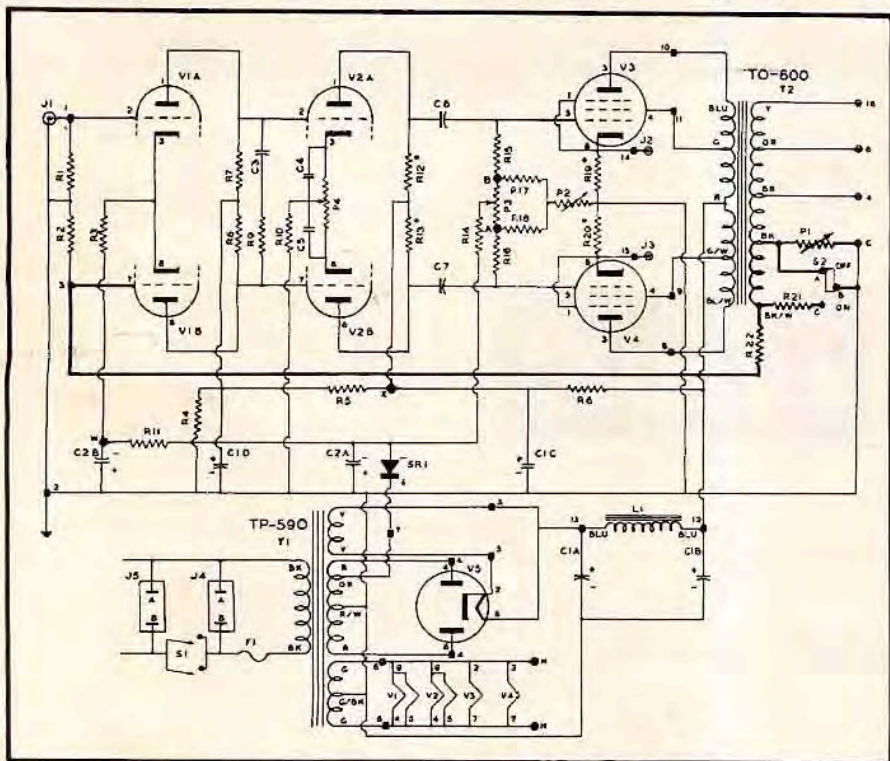

Fig. 2. Complete schematic of the Ultra-Linear II amplifier.

FEEDBACK

(from page 32)

nominal value, the damping factor of the amplifier is 4, a value which provides good operation with most speakers. However, other damping factors can be used, and while absolute isolation between load and feedback is not obtained, a sufficient degree is realized to be of positive benefit. For example, a capacitive load will not display ringing at any setting of the control. Moreover, the system has the beauty of supplying variable damping with insignificant increase in distortion, and maintains a constant amount of feedback so that output level is independent of the setting of the damping control. The complete schematic of the amplifier is shown in *Fig. 2*. Æ