

“DynaMutt” Driver Board for the Dynaco® ST-70

Noval Version

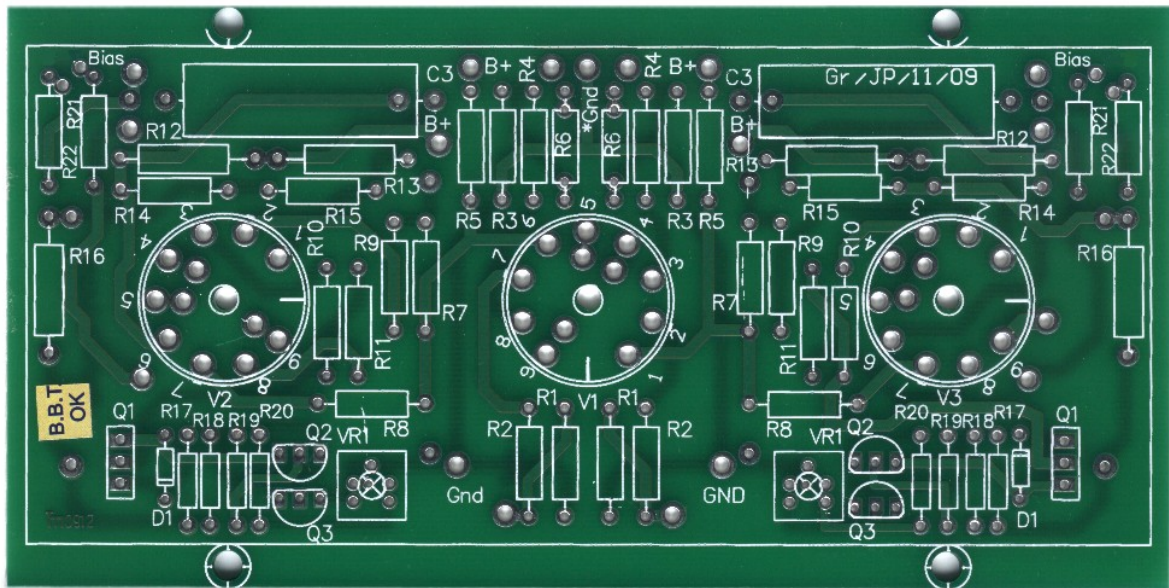

Design by:

Classic Valve Design



Classic Valve Design assumes no responsibility for circuit or user damage from the use or misuse of these boards or any other product. We simply provide these on an AS-IS basis with workmanship quality as the only thing guaranteed at this time.

This product is designed for and use around **LETHAL VOLTAGES**. We assume the user has a reasonably competent grasp of line operated electronics at the time of sale.



This driver board for the Dynaco® ST-70 provides you with a triode input and an AC auto balancing long tailed pair phase inverter for your vintage amplifier using some of the finest sounding triodes for audio amplification available.

Balanced AC audio signal drive to the output tubes is important for better quality audio reproduction. Linearity is improved and better high level performance is achieved.

In a nutshell, AC balance is maintained by the phase inverter having a small, local feedback loop that feeds an error correction signal to the constant current source (CCS) on the phase inverters cathodes, or "tail". This signal is inverted, the error is cancelled and AC balance is maintained. Equal anode load resistors on the phase inverter tube maintain the DC balance. Optimum performance is extracted from the phase inverter.

Credit for the invention of this AC balancing method goes to the late Fred Nachbaur (<http://dogstar.dantimax.dk/tubestuf/driver02.htm>), as used in his RA-100 reference amplifier. Adaptation to a solid state CCS was done by us at Classic Valve Design.

The name for this board was derived from our own ST-70 test amplifier, which went through some physical beautification changes even before the electrical ones, hence got the nickname, "DynaMutt" internally by the crew. It just stuck....

Please read this entire document before proceeding with construction.

Schematics

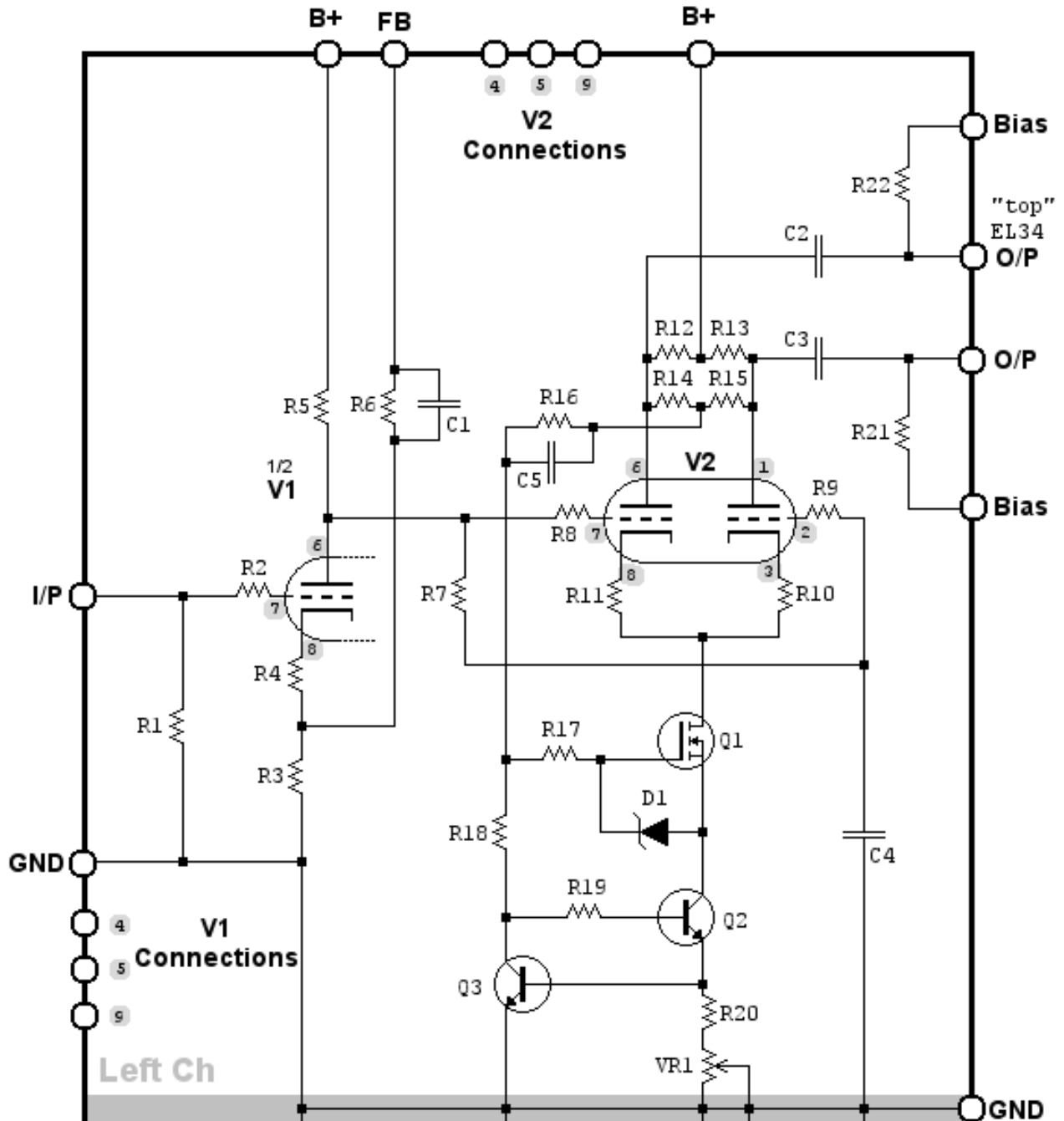

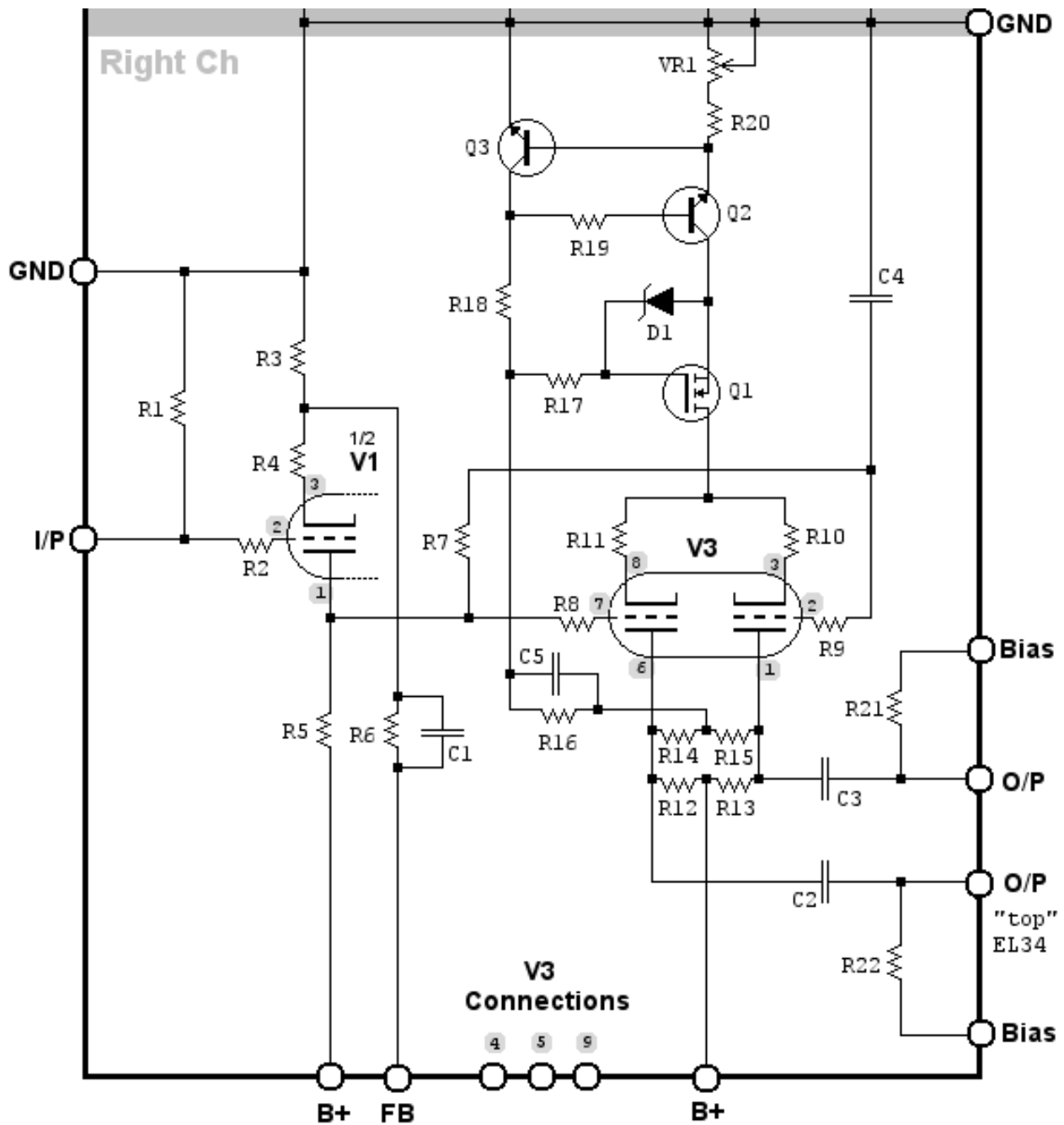

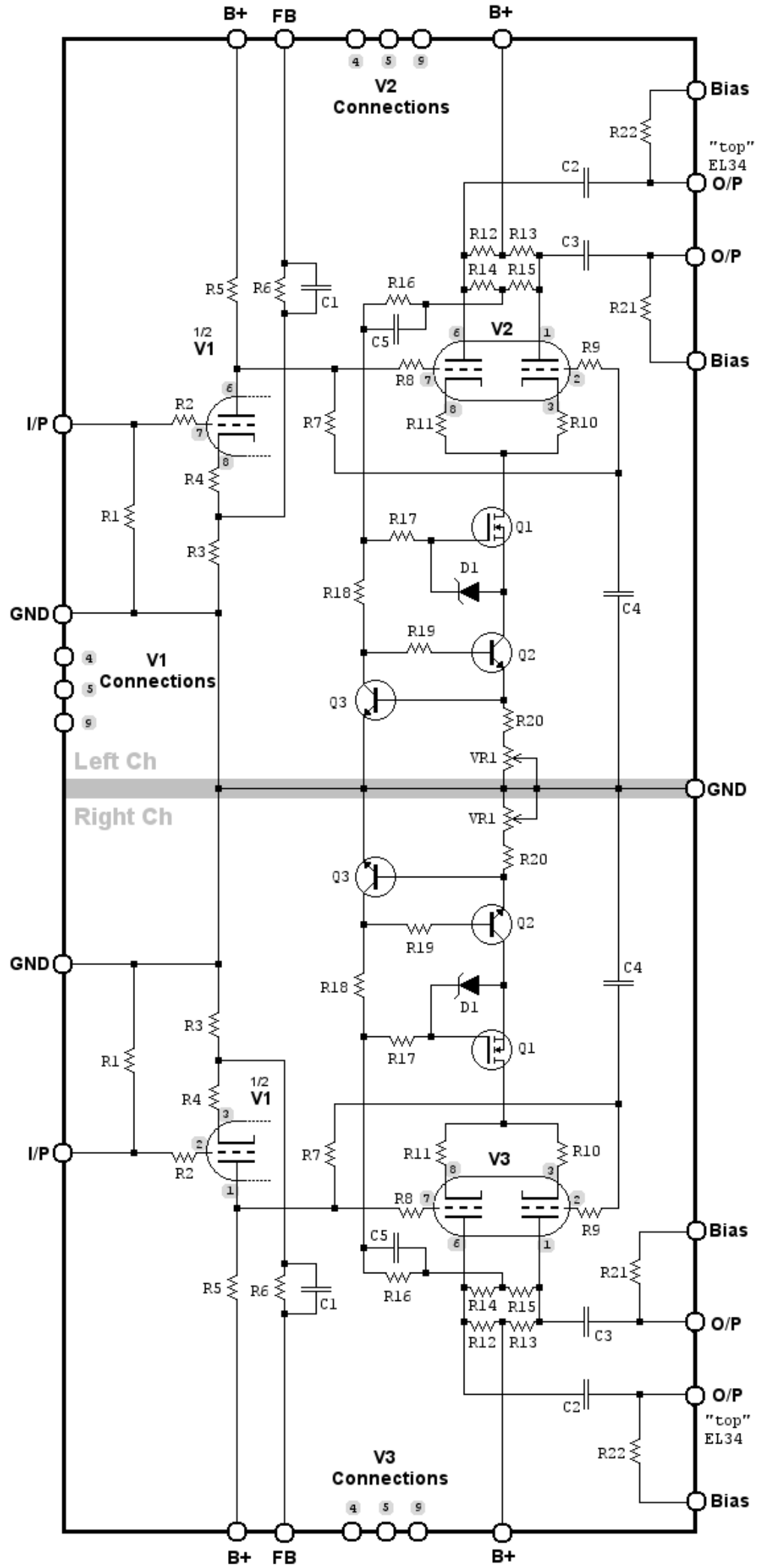

Parts Values **(each channel)**

Resistors:

(all ½ W, 5% unless noted)

R1, R7 – 1Meg

R2, R8, R9, R17, R19 – 220 ohms

R3 – (NFB resistor. 47 ohms I would say is maximum and gives 18dB NFB. High D.F. for hard to drive speakers (like 3-ways), but for 2-ways or full-rangers, I'd start around 22 ohms and tweak to taste from there. (one for each channel))

R4 – 1.2K

R5 – 100K

R6, R10, R11 – 1K

R12, R13 – 22K, 2W, metal oxide

R14, R15 – 47K

R16 – 470K, 2W, metal oxide

R18 – 10K

R20 – 20 ohms

R21, R22 – 150K

VR1 – 100 ohms trimmer (Digikey CT6EP101-ND or equiv.)

Capacitors:

(voltage ratings can be higher than listed)

C1 – 1.5n, 50V film

C2, C3, C4, C5 – 100n/630V film (polypropylene preferred here. 716P Orange Drops are great)

Semiconductors:

Q1 – IRF 710

Q2, Q3 – 2N2222, 2N4401, etc.

D1 – 1N4739A, 9.1V zener

Misc:

- Heat sinks for Q1. Aavid Thermalloy 504222B00000G, Digikey HS104-2-ND or equiv.
- Insulating pad/hardware if you want the sinks electrically isolated.

Bill of Materials

(does not include power supply changes listed later)

Resistors:

(all ½ W, 5% unless noted)

2 - 20 ohms
2 - 100 ohms variable trimmer. Digikey CT6EP101-ND or equiv.
10 - 220 ohms
6 - 1K
2 - 1.2K
2 - 10K
4 - 22K, 2W, metal oxide
4 - 47K
2 - 100K
4 - 150K
2 - 470K, 2W, metal oxide
4 - 1Meg

Capacitors:

(voltage ratings can be higher than listed)

2 - 1.5n, 50V film
8 - 100n, 630V film (polypropylene pref.)

Semiconductors:

2 - IRF710
4 - 2N3904
2 - 1N4739A, 9.1V zener

Valves:

1 - 5751
2 - 6CG7/6FQ7
3 - PCB mount noval (9-pin miniature) sockets

Misc:

2 - Heat sinks, Aavid Thermalloy 504222B00000G, Digikey HS104-2-ND or equiv.
2 - sets insulating pad/hardware if you want the sinks electrically isolated.

R3 - NFB resistor. 47 ohms I would say is maximum and gives 18dB NFB. High D.F. for hard to drive speakers (like 3-ways), but for 2-ways or full-rangers, I'd start around 22 ohms and tweak to taste from there. (one for each channel)

Assembly

Assembling this board is fairly straight forward and Classic Valve Design assumes you have assembled PCB components before. This is **NOT** a beginner project. Making mistakes from this point on can seriously damage your ST-70 amplifier and cause a safety risk.

Due to the pads and traces being close together (ST-70 driver board physical space is very limited), it is *critical* that excellent soldering techniques are used. Cold solder joints or worse, joints with sharp edges or excess solder (blobs) can cause a short circuit, damaging your ST-70.

Cleaning excess flux off the board is good practise as well. Acetone based nail polish remover and a toothbrush is the simplest and most easily obtainable method for those not using water soluble flux. Many tube enthusiasts use more activated flux, like Kester “48” or “88” cores. These fluxes are *electrically conductive* and must be removed before power up.

Components are mounted on both sides of the boards. This means there is an order to the way things go in:

- Install C1 on both channels. Use the inside pads (R6 uses the outside ones).
- Install D1 on both channels.
- Install all ½ watt resistors (all resistors except R12, R13 and R16).
- Install VR1 on both channels.
- Install R12, R13 and R16 on both channels.
- Install Q2 and Q3 on both channels.
- Install the noval PCB sockets.
- Install Q1 on both channels.
- Install C3 on both channels, leaving about ¼” gap between it and the board. Clip C3's solder joint so no sharp points remain.
- Install C2 on both channels. One pad is under C3, so you'll have to rim that lead so it's no more than 1/8” through the hole (about ½ way to C3's belly). Solder that lead from the bottom of the board (C2's side) and let the plated-through-hole of the PCB take care of the wicking to the other side.
- Install C4 and C5 on both channels.

C2 (bottom) and C3 (top) are just slightly offset from each other and it is really easy to make a mistake here. The silkscreen shows the exact pads these capacitors go to, as shown in the pictures on the next page.

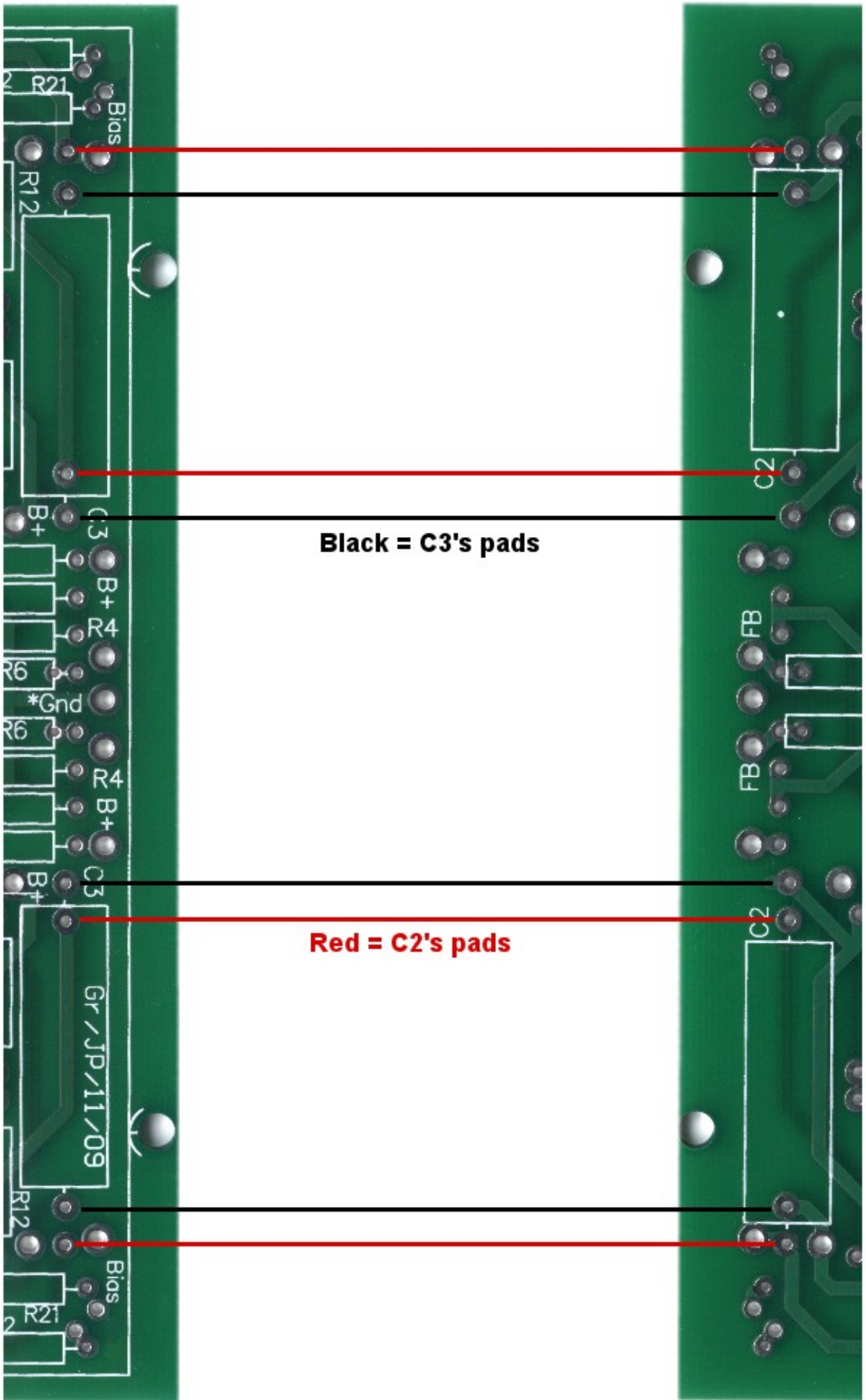

Black = C3's pads

Red = C2's pads

Installation

The DynaMutt driver board, unlike other ST-70 driver boards have the chassis mounting holes of 5/32" to clear #6-32 mounting screws. The larger holes are used as #4 hardware is getting very hard to find other than in metric equivalent sizes (at least it is around our R&D facility near Vancouver, BC... which is not a small town by any means). The original Dynaco hardware may not be able to secure it, but modern #4-40 hardware does.

Wiring this board is outlined in the image on the following page.

Just what is meant by "Top" and "Bottom" EL-34 grids? Well, it's in reference to the way the original ST-70's output stage is drawn.

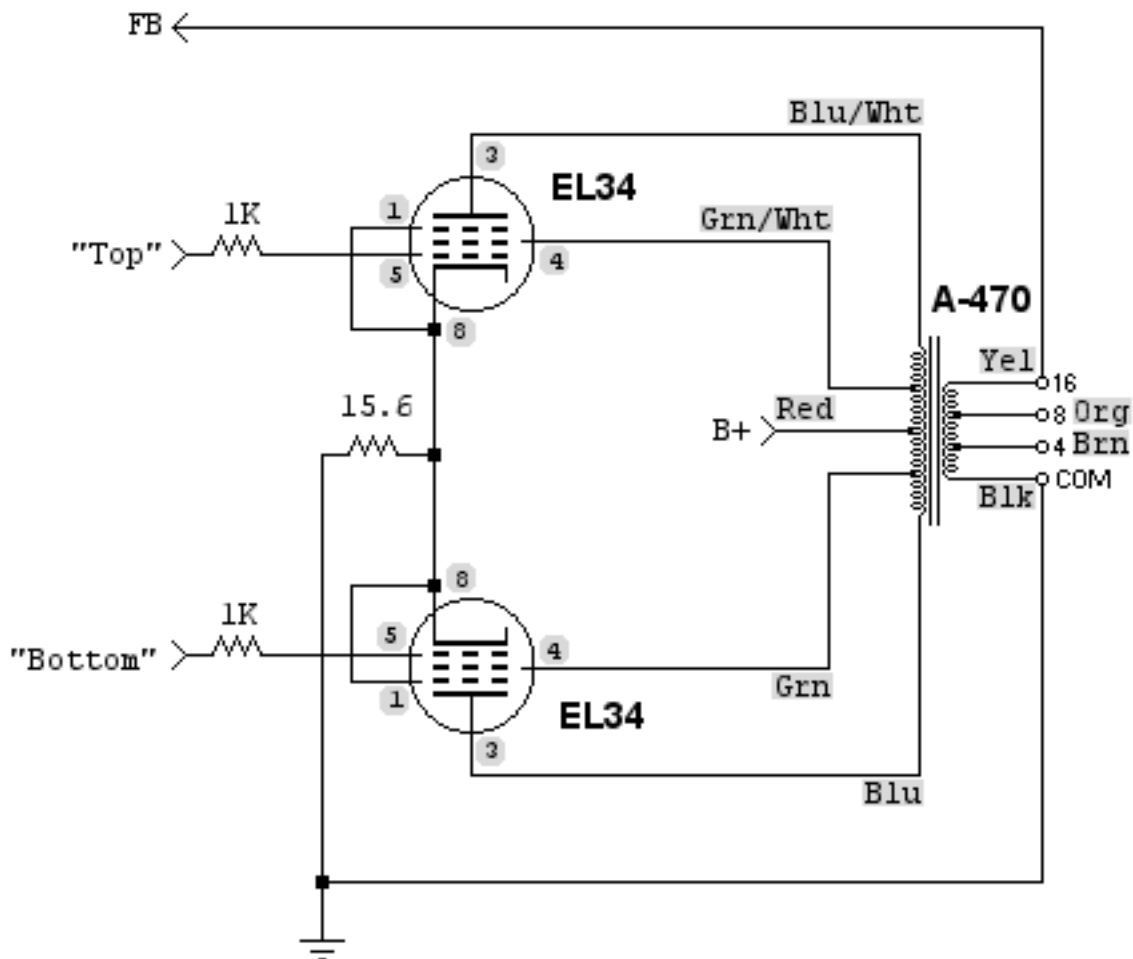

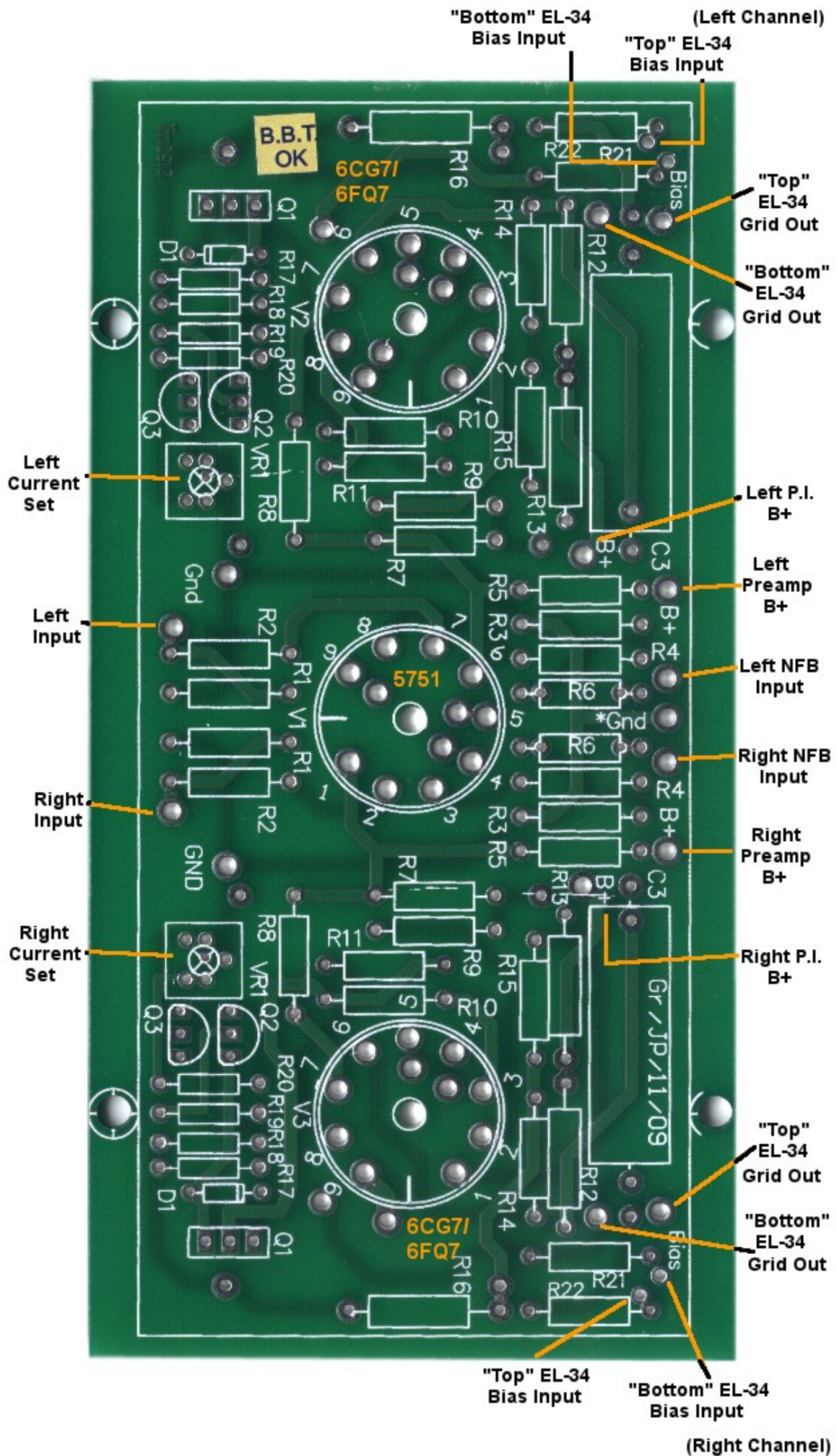

Obeying this keeps the proper phase of the NFB. This is very important as if the grid drive is reversed, it will turn your ST-70 into a power oscillator damaging not only your amplifier, but your speakers and likely your hearing in the process.

The B+ on the DynaMutt driver board is seemingly ambiguous. Each tube section of the 5751 and each 6CG7/6FQ7 is brought out to its own "B+" (total of four).

During the R&D process for this board, it was determined many DIY'ers (some of the crew that helped us develop this as a matter of fact) preferred a separate power supply for each channel. Therefore the necessity of bringing the power pads out this way.

To use this board in a standard ST-70 power supply:

- Tie the two "B+" for the 5751 together (these lead to R5 on each channel). This is the "Preamp supply". Also known as "Supply A" on the original Dynaco power supply schematic.
- Tie the two "B+" for the 6CG7/6FQ7 together (these are at the junction of R12 and R13 on each channel). This is the "Phase Inverter (PI) supply". Also known as "Supply B" on the original Dynaco power supply schematic.

The bias supply is designed to be able to be used singly (as in the original ST-70 design) or split, should you have a PCB or modification that allows each tube to be biased separately.

To use it singly in the original ST-70 bias configuration:

- Tie the two "Bias" inputs for the left channel together. This will go to the right or left bias resistor mounted on the ST-70 chassis. Do the same for the right channel.

Otherwise, follow the instructions that accompany your specific power supply board for using a split biasing supply.

Heater Wiring

The pins 4, 5 and 9 on each valve are brought out to their own pads. This is to allow you to experiment with valves other than those recommended by us. For the recommended tubes, wire them:

- On the 5751, tie pin pads for 4 and 5 together. Those along with the pad to pin #9 go to the heater supply (doesn't matter which).
- On the two 6CG7/6FQ7's, pads for pins 4 and 5 go to the heater supply of their respective sides and the pad for pin 9 goes to GND.

Power Supply Modification

As mentioned earlier, the Bill of Materials did not include power supply components. For use with a stock ST-70 power supply, only the B+ divider resistors need a change.

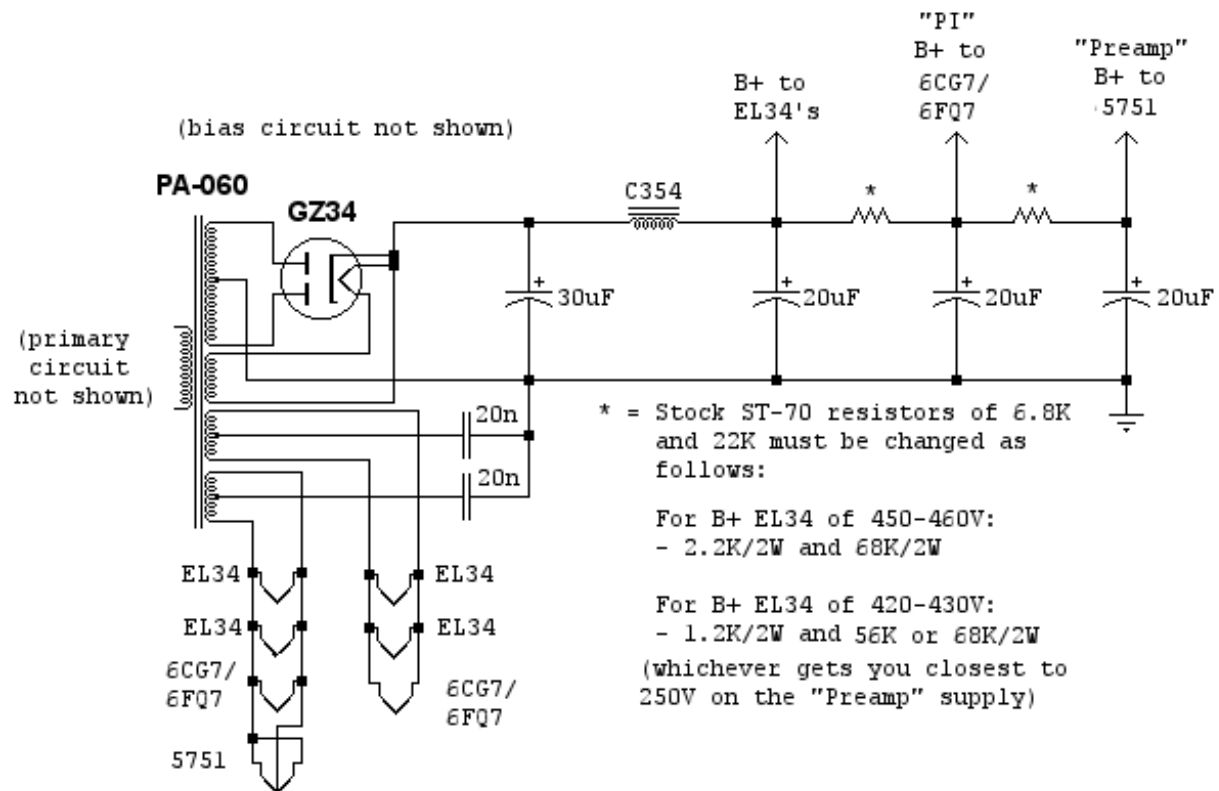

In our R&D of this board, it was found that the output voltage of the stock PA-060 varied pretty significantly depending on line voltage. At our facility, line voltage is almost constant at 125VAC with a measured high of 126.3V and low of 123V. Therefore our PA-060 was putting out an incredible amount of voltage and we used 2.2K, 2W and 68K, 2W.

When we displayed this amp publicly at a festival, line voltage was flying widely from 119V to 123V, which required a tweak of 56K for the second resistor for proper display.

The driver preamp to PI is DC coupled, so aiming for target values should have an effort put into it. Tested acceptable voltages are:

P.I. B+ voltage: 390-415V

Preamp B+ voltage: 240-270V

As you can see it's not overly critical on the 5751, as the CCS on the PI tail can do some compensation. However too high B+ on the PI limits your maximum output power, too low makes distortion increase across all power levels.

Testing and Alignment

Once you have double and triple checked your connections to the driver board, go back and check them again. Set each VR1 to centre position.

Ideally, you will have your ST-70 tied into a dummy load instead of speakers for the initial power up. Tools needed for optimum alignment:

- Multimeter
- Oscilloscope
- 1KHz sine wave generator

Hook your multimeter first up to your EL34 grids and measure for negative DC. As always on power up of a fixed bias amplifier, you want to check for bias on the grids and power down immediately if your meter doesn't head for about -39V area (typical EL34 bias on a ST-70).

Once you have confirmed bias, check the anode of each section of the 5751 for voltages ranges listed above. Repeat for anodes of each 6CG7/6FQ7.

For optimum VR1 setting, hook your oscilloscope to the amplifier's left speaker output with a dummy load. Feed your ST-70 with a 1KHz sine wave into the left channel. Increase the generator in amplitude until the amplifier begins compression of the sine. Adjust VR1 for perfectly symmetrical compression or clipping of the sine. Repeat for right channel.

In our tests, VR1 did not need much more than about 15% adjustment from centre slot with a variety of valves of various brands. If you do not have an oscilloscope or a friend with one, set at centre slot and do some listening and make small adjustments up and down. Your ears will find a position that sounds "cleanest" at high volumes. Good chance it won't be too far off.



"DynaMutt" design is Copyleft 2009 Gregg van der Sluys, Classic Valve Design and is licensed under Creative Commons: <http://creativecommons.org/licenses/by-nc-sa/2.5/ca/>

Please enquire for commercial interests in this design or derivatives.

www.CLASSICVALVE.ca