

APOGEE TECHNOLOGY, INC.		
129 MORGAN DRIVE NORWOOD, MA 02062		
Title		DDX REFERENCE DESIGN 5.1 CHANNELS
Size	Document Number	Rev
B	<Doc>	-A-
Date:	Tuesday, April 10, 2001	Sheet 1 of 6

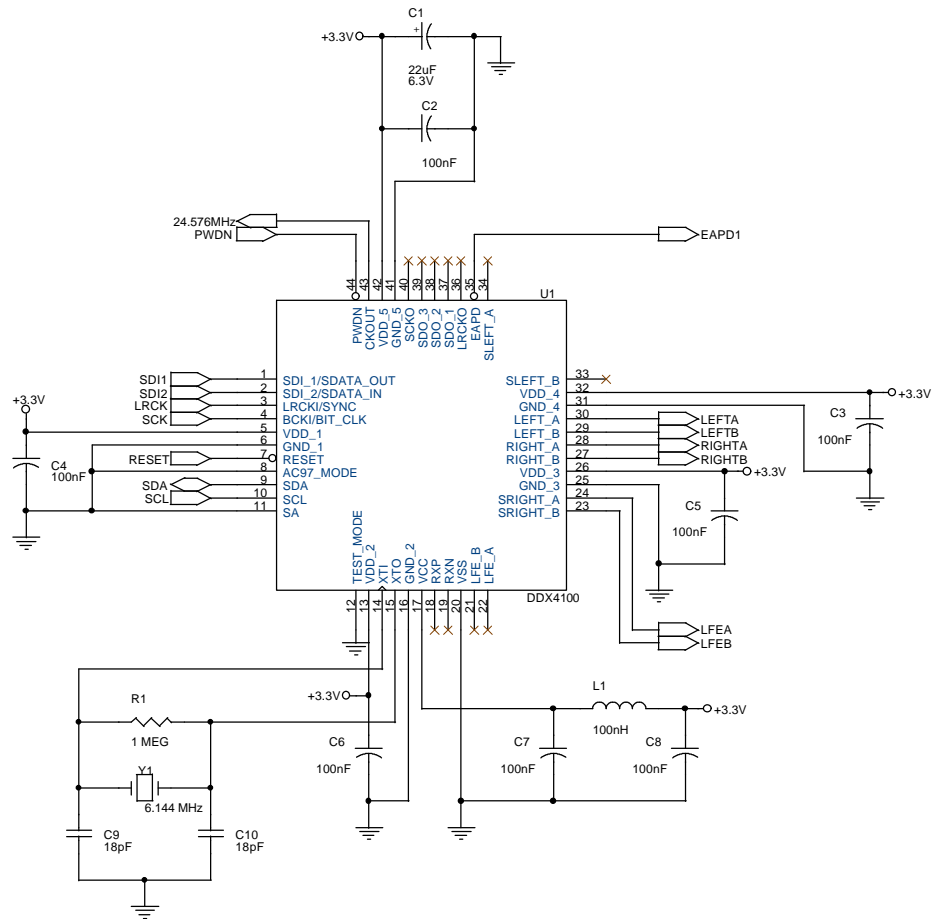

APOGEE TECHNOLOGY, INC.		
129 MORGAN DRIVE NORWOOD, MA 02062		
Title 5.1 CHANNEL REFERENCE SCHEMATIC L,R,LFE DIGITAL CONTROL		
Size B	Document Number <Doc>	Rev --
Date: Tuesday, April 10, 2001	Sheet 2	of 6

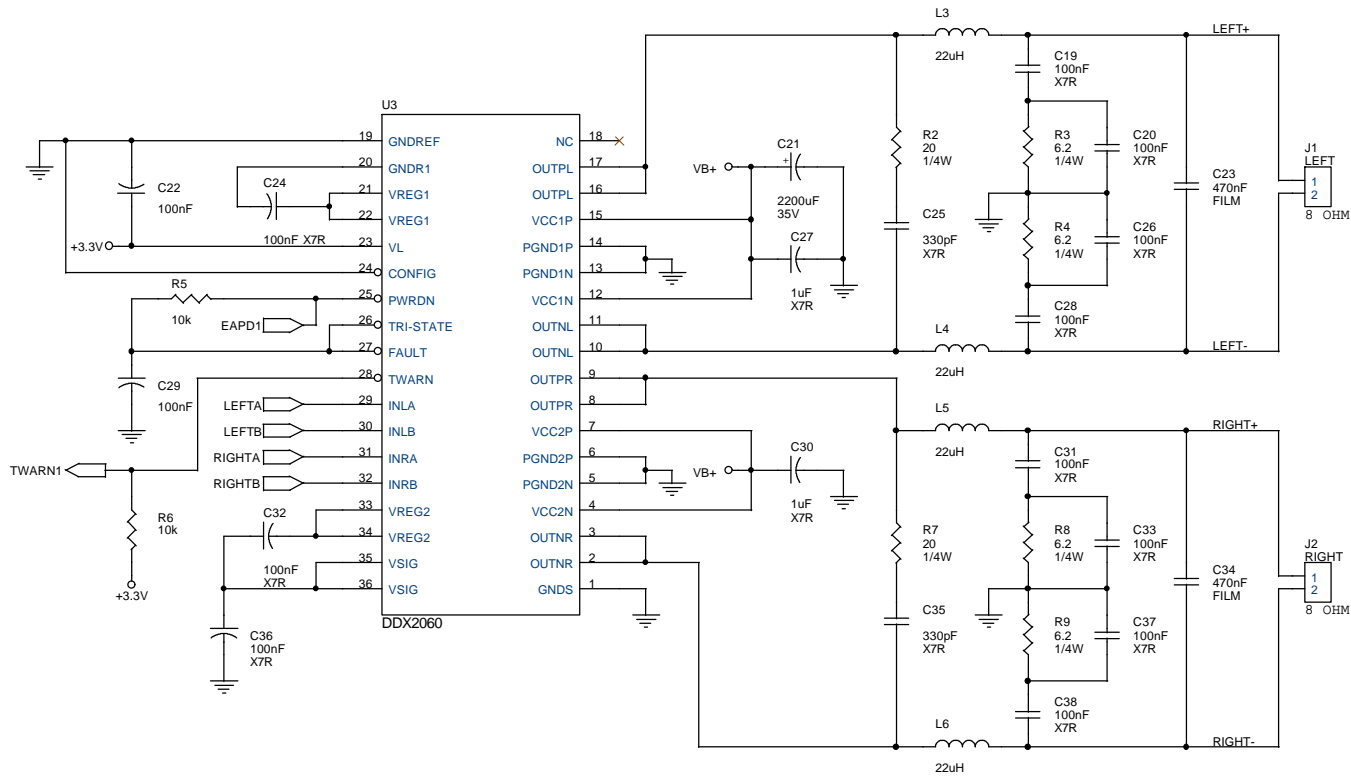

APOGEE TECHNOLOGY, INC.
 129 MORGAN DRIVE
 NORWOOD, MA 02062

Title
 5.1 CHANNEL REFERENCE SCHEMATIC L,R OUTPUTS

Size B	Document Number <Doc>	Rev --
-----------	--------------------------	-----------

Date: Tuesday, April 10, 2001 Sheet 4 of 6

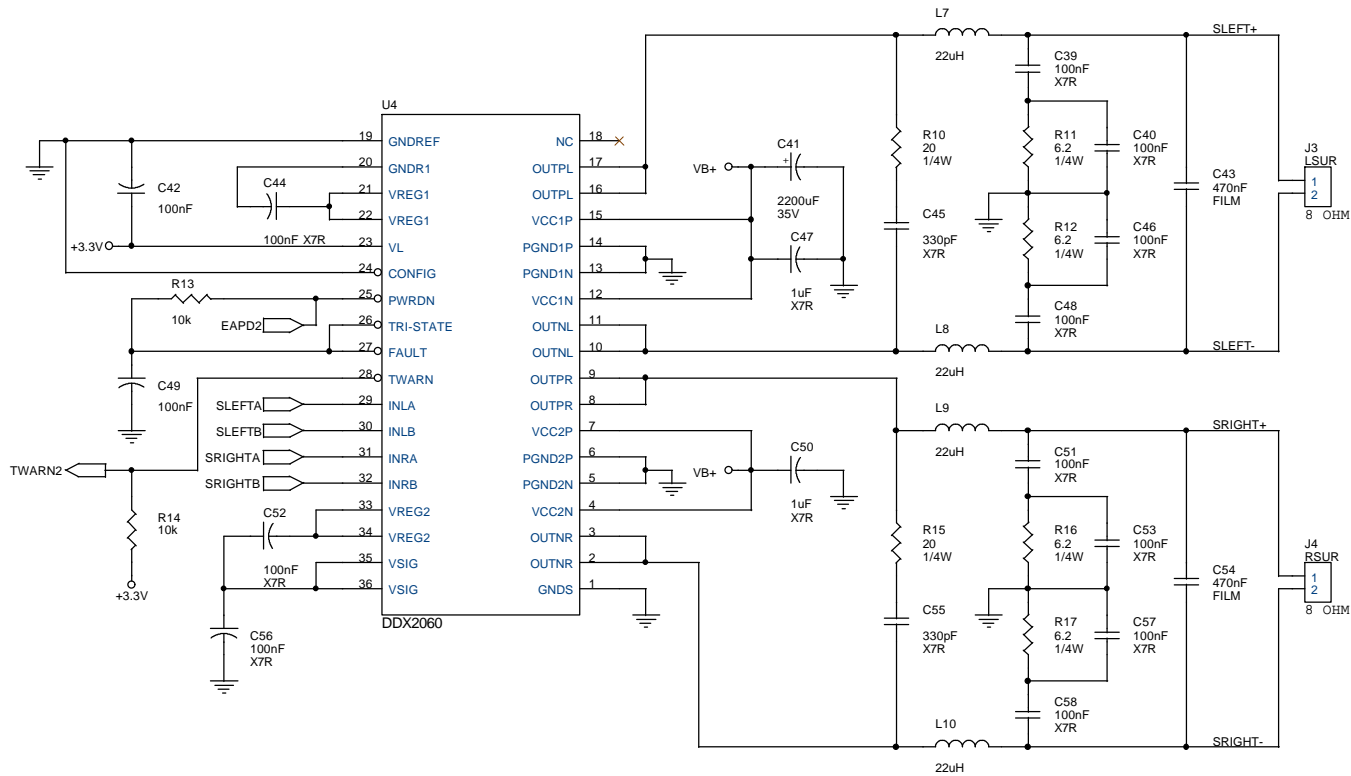

APOGEE TECHNOLOGY, INC.		
129 MORGAN DRIVE NORWOOD, MA 02062		
Title 5.1 CHANNEL REFERENCE SCHEMATIC LS,RS OUTPUTS		
Size B	Document Number <Doc>	Rev --
Date: Tuesday, April 10, 2001	Sheet 5	of 6

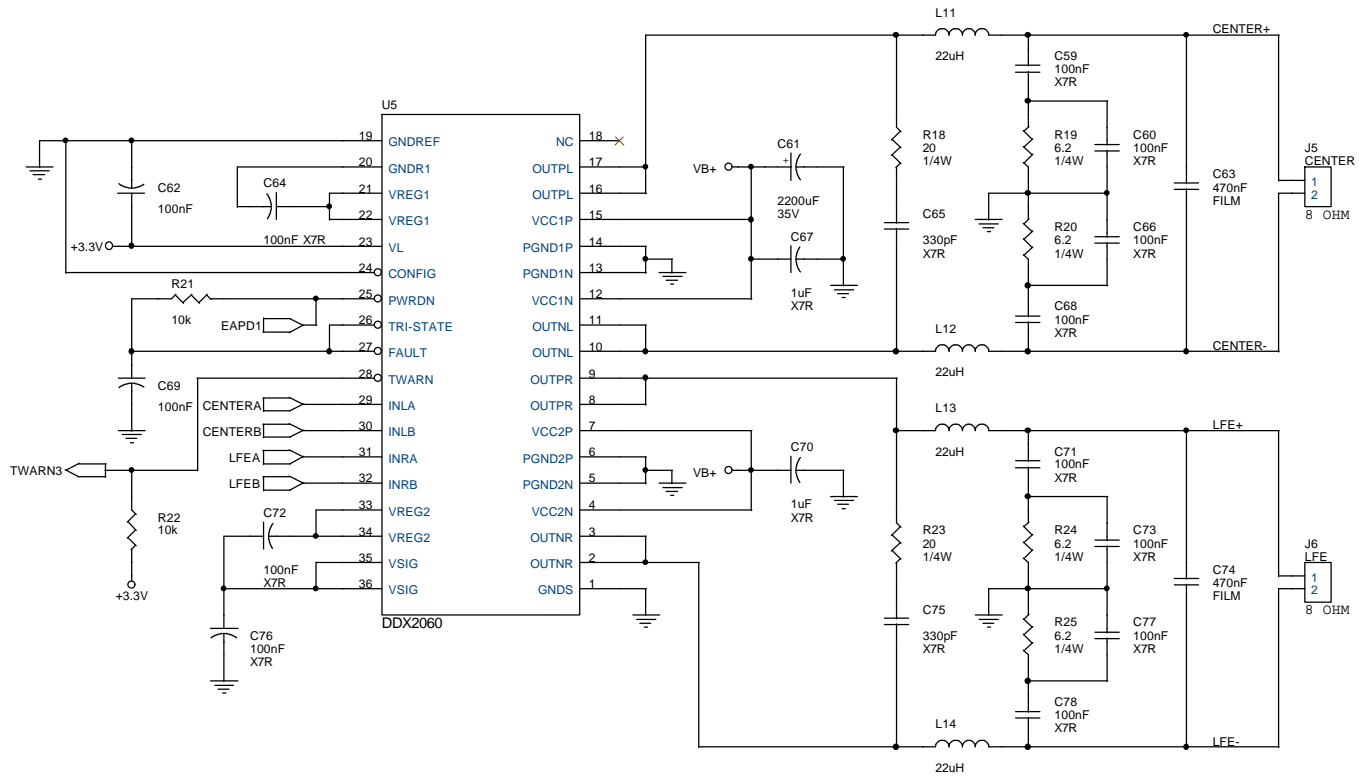

APOGEE TECHNOLOGY, INC.
 129 MORGAN DRIVE
 NORWOOD, MA 02062

Title
 5.1 CHANNEL REFERENCE SCHEMATIC C,LFE OUTPUTS

Size B	Document Number <Doc>	Rev --
Date: Tuesday, April 10, 2001	Sheet 6	of 6