



Kattegat 8
 9723 JP Groningen, The Netherlands
 +31 50 526 4993
 sales@hypex.nl



Voltage Gain of the UcD Modules

Hypex UcD modules are sold with the voltage gain pre-set at 20 times (26dB). This is an arbitrary choice. Topologically the module is an instrumentation amplifier, so gain can be changed by changing only a single resistor.

Gain Structure

Bare UcD stage

When we strip the UcD circuit of all its reactive components (inductors and capacitors) and replace the comparator plus the switching power stage with a linearised approximation we get the DC equivalent model. It looks like this:

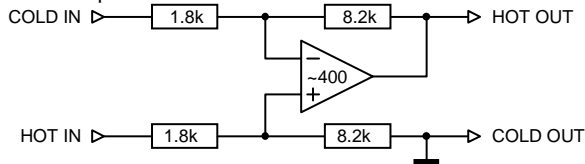

This is a difference amplifier. Gain is not quite 8.2k/1.8k because of the finite gain of the switching output stage. It works out as 4.5 times.

The input impedance of this circuit is quite low. On the hot side it's 10k referred to ground, on the cold side it's 10k referred to output. Forget what is commonly said about the cold input impedance being 1.8k referred to the virtual short, which in turn is a function of the hot input voltage. This explains why it is not possible to make a one-opamp difference amplifier with balanced impedances – the input impedance is balanced, but each refers to a different circuit node.

This in combination with the lowish impedance calls for a buffer stage.

Differential buffer stage

The difference amplifier circuit almost begs to be used in an instrumentation amp. A differential gain buffer is added:

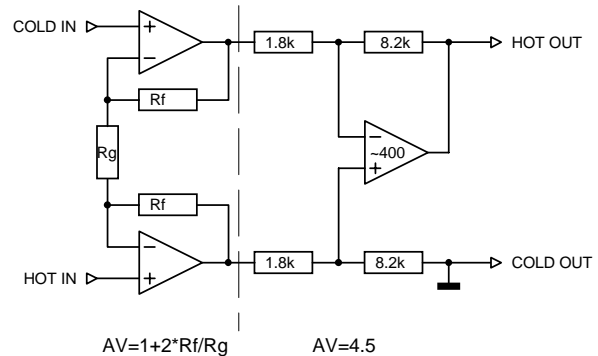

The differential mode gain of the first stage is $1 + 2 \cdot R_f / R_g$. The common mode gain is 1 and no conversion from common mode to differential mode takes place. The CMRR performance of the difference stage (the UcD block) is directly improved by a factor equal to the gain of the first stage. This is a very strong argument in favour of making the gain of the UcD as low as possible, just high enough that the buffer stage can still drive it comfortably. A second argument lies in the fact that the input transistors of the UcD comparator are not matched. Although it's perfectly possible to make a modulator with a gain of 30dB, doing so exacerbates the effects of offset voltage. Again a good reason to shift the burden of gain towards the differential buffer stage, which is built with op amps.

Practical

$$A_v = 4.5 \times \left(1 + 2 \times \frac{R_f}{R_g} \right)$$

Changing gain involves no more than changing Rg. Until recently, all modules were stuffed with $R_f = 1k$ and $R_g = 560\Omega$. At the time of writing this is being changed to 2.2k and 1.2k.

To verify which values are used on your module, the position numbers for R_f and R_g on the various modules are:

Model	Rf	Rg
UcD700	R58, R59	R57
UcD400	R4, R14	R3
UcD180	R11, R12	R10

Bruno Putzeys