

## High Efficiency Power Amplifier Module (OEM Version)

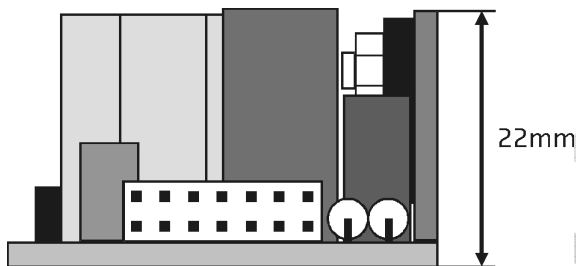
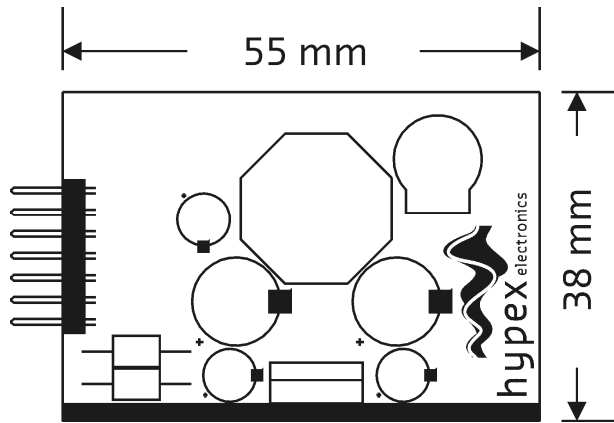

### Highlights

- Flat, fully load-independent frequency response
- Low output impedance
- Very low, frequency-independent THD
- Very low noise
- Fully passive loop control
- Consistent top performer in listening trials

### Features

- Runs on unregulated +/- rails
- Pop-free start and stop control
- Differential audio input
- DC-fault detection
- Overcurrent and overvoltage protection
- Weight: 45g

### Applications

- Monitor loudspeakers for recording and mastering studios
- Audiophile power amplifiers for professional and consumer use
- Public Address systems
- Home theatre systems
- Active loudspeakers

### Description

The UcD100™ (OEM version) amplifier module is a self-contained high-performance class D amplifier intended for a wide range of audio applications, ranging from Public Address systems to ultrahigh-fidelity replay systems for studio and home use. Chief distinguishing features are flat frequency response irrespective of load impedance, nearly frequency-independent distortion behaviour and very low radiated and conducted EMI. Control is based on a phase-shift controlled self-oscillating loop taking feedback only at the speaker output.

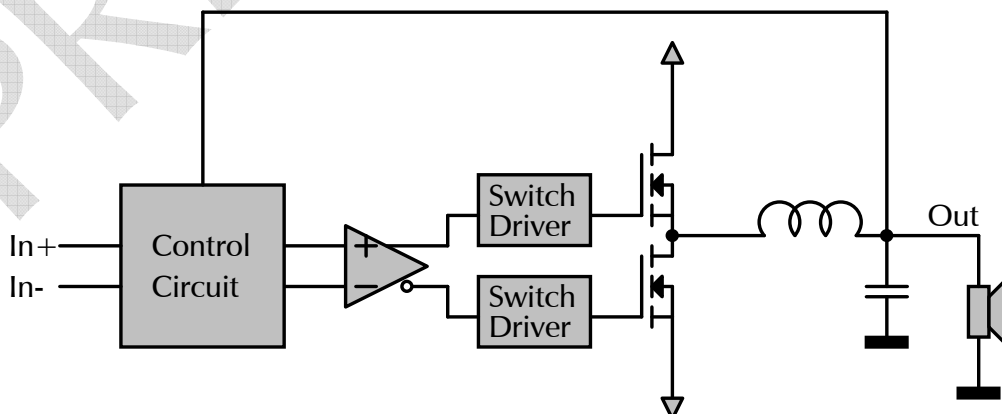

## Performance data

Power supply = +/-35V, Load=4Ω, MBW=40kHz, unless otherwise noted

Item	Symbol	Min	Typ	Max	Unit	Notes
Output Power	$P_R$	100	-	-	W	THD=1%
Distortion	THD+N	-	0.05	0.15	%	20Hz<f<20kHz. Pout<PR/2
		-	0.003	0.01	%	20Hz<f<20kHz Pout=1W
Output noise	$U_N$	-	30μ	35μ	V	Unwtd, 20Hz-20kHz
Output Impedance	$Z_{OUT}$	-	-	20m	Ω	f<1kHz
		-	-	150m	Ω	f<20kHz
Power Bandwidth	PBW		20-35k		Hz	
Frequency Response		10	-	50k	Hz	+0/-3dB. All loads.
Voltage Gain	$A_V$	12.5	13	13.5	dB	
Supply Ripple Rejection	PSRR		65		dB	Either rail, all frequencies.
Efficiency	$\eta$		92		%	Full power
Idle Losses	$P_o$		1.5		W	
Standby Current	$I_{STBY}$		1m		A	
Current Limit			10		A	

## Audio Input Characteristics

Item	Symbol	Min	Typ	Max	Unit	Notes
Input Impedance	$Z_{IN}$		1.8k		Ω	Either input to ground
Common Mode Rejection Ratio	CMRR		75		dB	All frequencies

## Absolute maximum ratings

Correct operation at these limits is not guaranteed. Operation beyond these limits may result in irreversible damage.

Item	Symbol	Rating	Unit	Notes
Power supply voltage	$V_B$	+/-50	V	Unit shuts down when either rail exceeds 47V
Peak output current	$I_{OUT,P}$	10	A	Unit current-protects at 10A
Input voltage	$V_{IN}$	+/-12	V	Either input referred to ground
Air Temperature	$T_{AMB}$	65	°C	
Heat-sink temperature	$T_{SINK}$	90	°C	User to select heat sink to insure this condition under most adverse use case

## Recommended Operating Conditions

Item	Symbol	Min	Typ	Max	Unit	Notes
Power supply voltage	$V_B$	25	35	45	V	
Load impedance	$Z_{LOAD}$	1			Ω	
Source impedance	$Z_{SRC}$				Ω	Differential. Corresponds to 3dB noise increase.
Effective power supply storage capacitance	$C_{SUP}$	4700μ			F	Per rail, per attached amplifier. 4Ω load presumed.

## Connections

In order to ease connecting the amplifier, all necessary connections to operate the amplifier are grouped in one standard 2.54mm pitch dual row 14 pin header.

Pin	Function
1, 3	Negative power supply connection
2, 4	Positive power supply connection
5, 6	Power supply ground connection*
7	ON/OFF control (Active low)
8	DC-fault detection (Open collector - Active low)
9	Non-inverting audio input
10	Inverting audio input
11, 13	Loudspeaker connection (hot)
12, 14	Loudspeaker connection (cold)*

\* Pin 5, 6, 12 and 14 are physically connected to the same potential ( ground ).

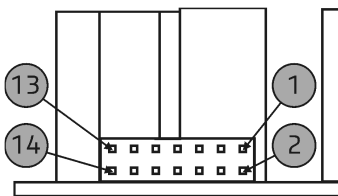

Fig1. Connector pinning UcD100™ (OEM version).

## DC-fault Detection Characteristics

The UcD100™ (OEM version) has an integrated DC-error detection which will pull pin 8 low in case of such an event. It is recommended to sense this fault condition and to interrupt both power supply lines in such an event.

Item	Min	Typ	Max	Unit	Notes
Voltage on pin 8, DC-error			1	V	Internal open collector*

\* Must be pulled to a positive voltage by means of an external resistor.

## Amplifier Enable Characteristics

The UcD100™ (OEM version) is enabled by pulling pin 7 low. Leaving pin 7 floating will put the amplifier in standby.

Item	Min	Typ	Max	Unit	Notes
Voltage on pin 7, left floating			6,5	V	Internally pulled up*

\* Must be pulled low by means of an open collector.

## Amplifier start-up delay

During initial power up the amplifier is disabled for approx. 1.5s regardless of the state of pin 7. Once powered up there is no start or stop delay.

## Typical Performance Graphs

**THD vs. Power (1kHz, 4Ω)**

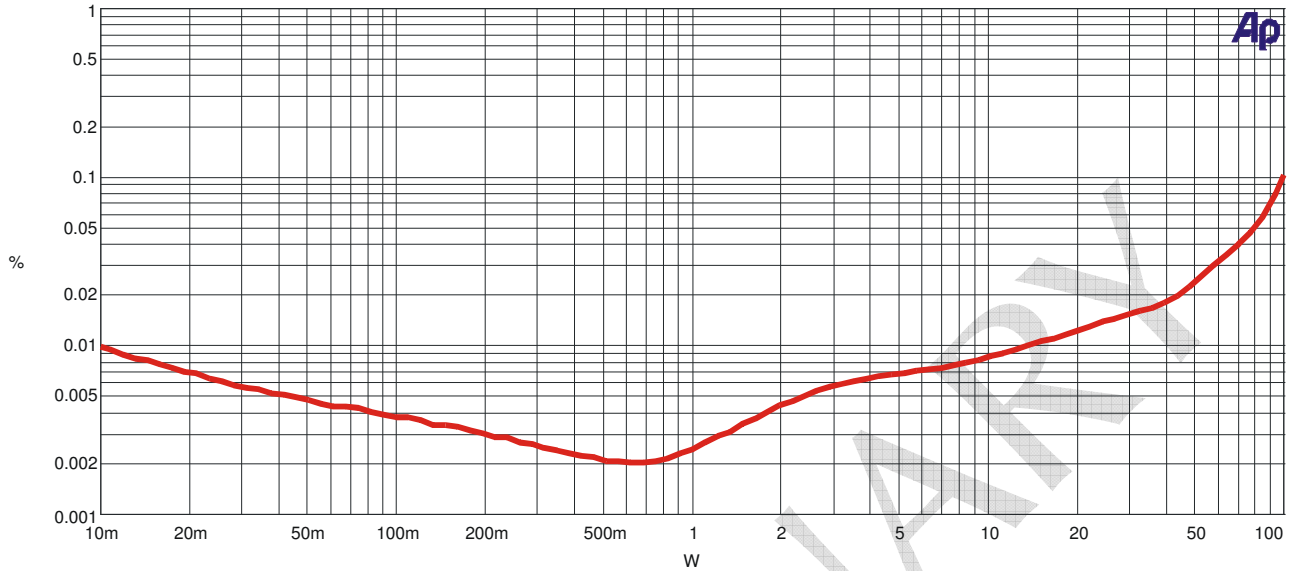

**THD vs. Frequency (8Ω)**

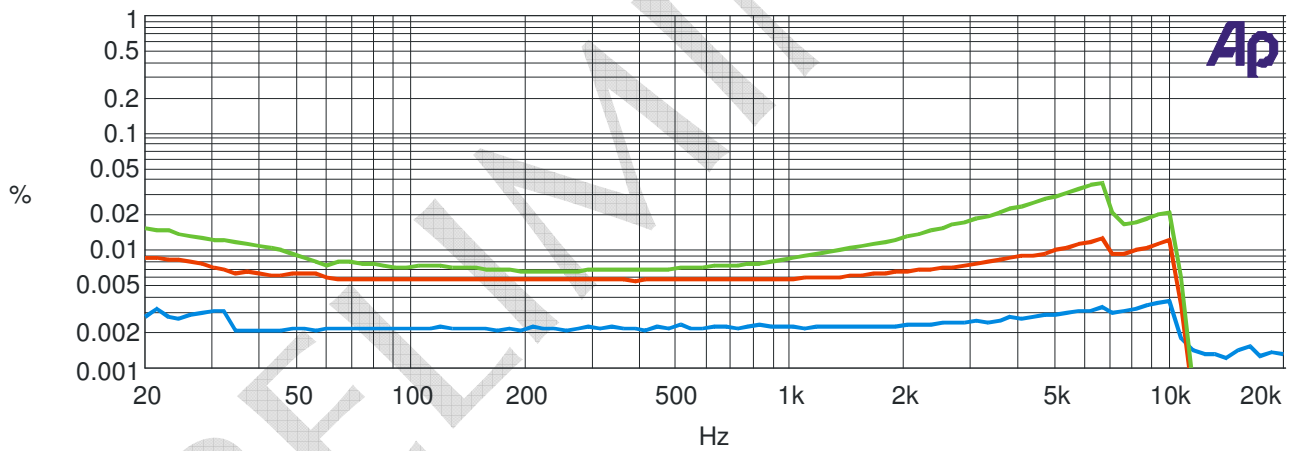

From top to bottom: 40W, 10W, 1W

**Frequency Response (4Ω, 8Ω and open circuit)**

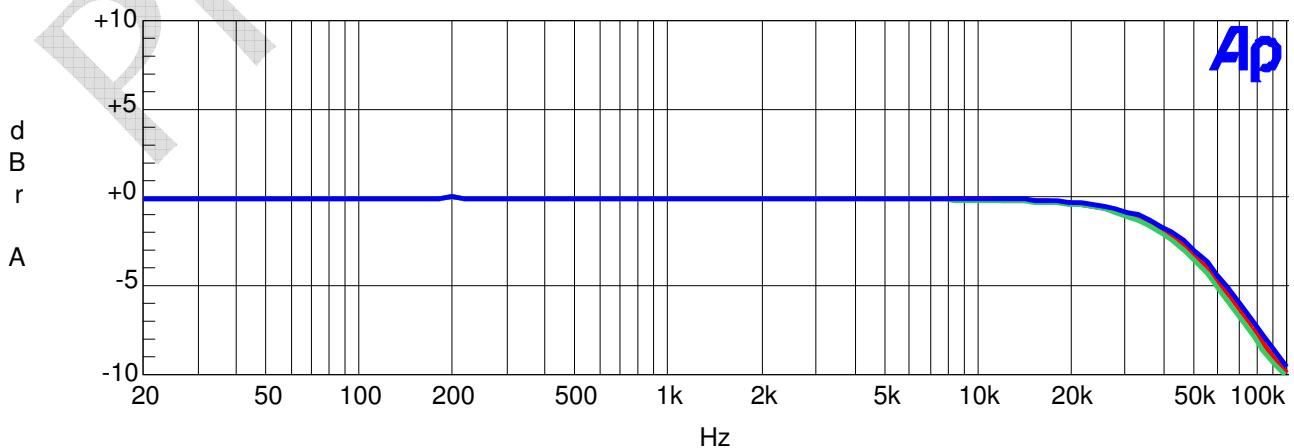

From top to bottom: open circuit, 8Ω, 4Ω

### Output Impedance

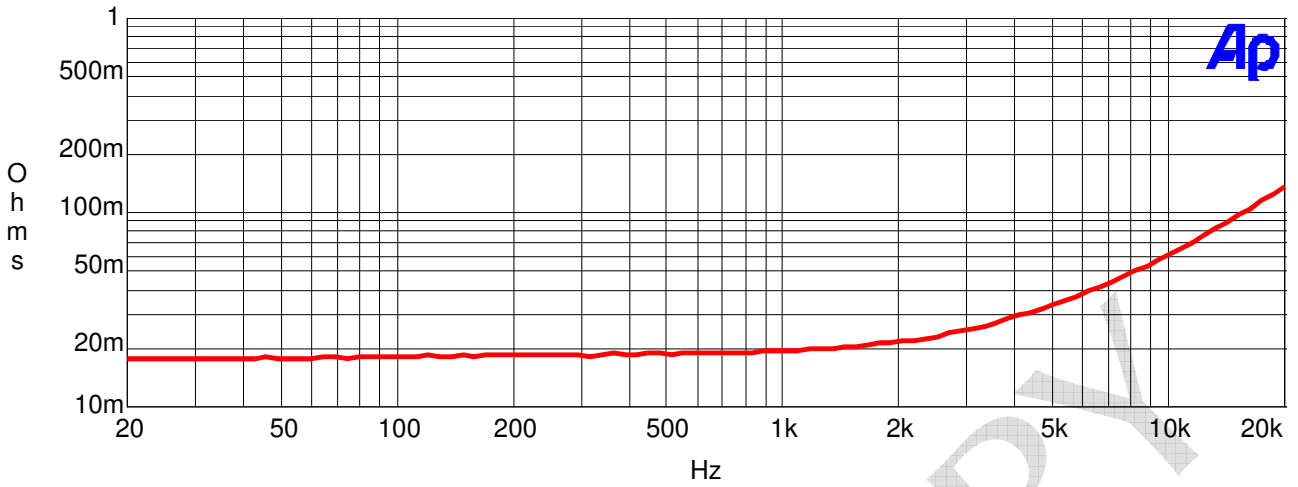

### 19+20kHz IMD (10W, 8Ω)

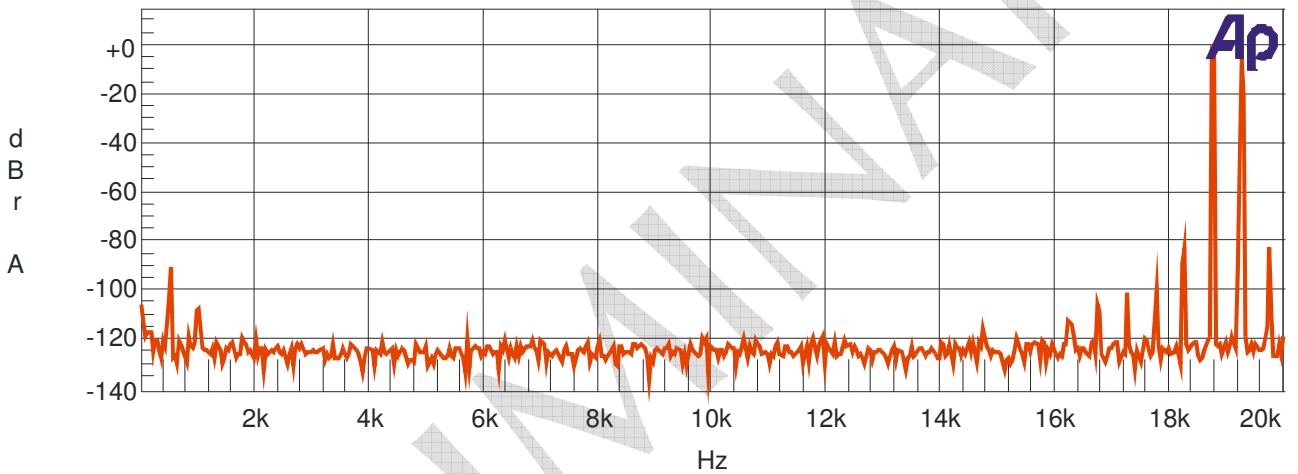

Connector layout. Top view / Frontview

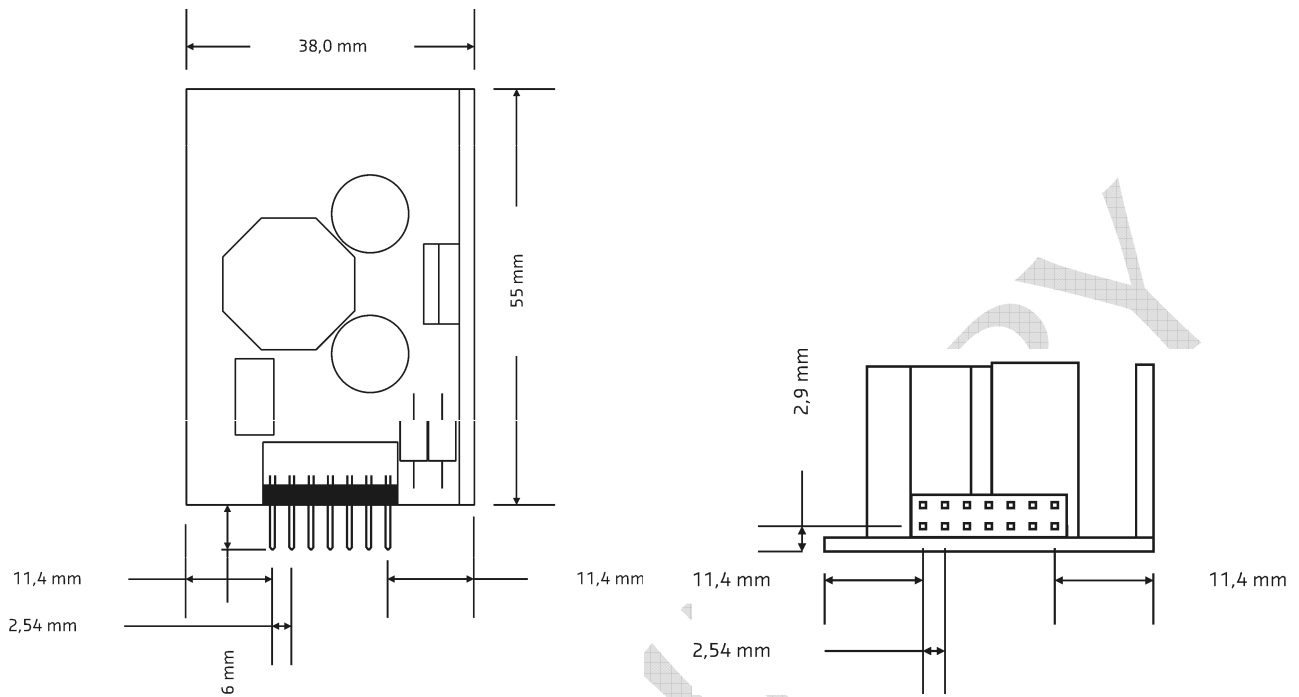

Heatsink drill pattern. Side view.

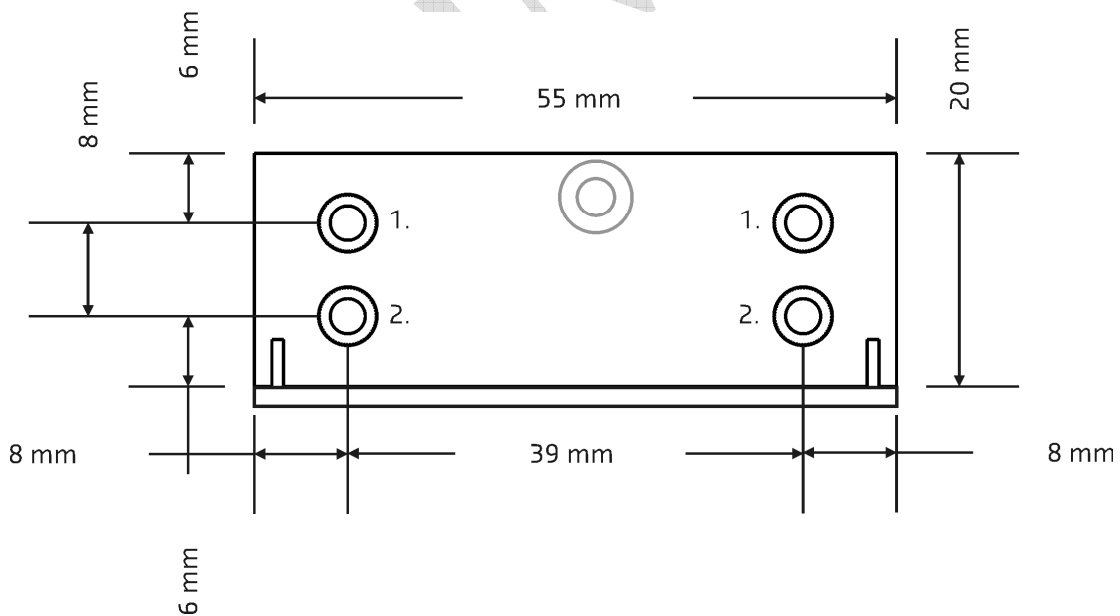

1. Push-in nut Metric M3
2. Push-in nut UNC 6-32