

TPA32xx Analog Input Grounding for Single Ended Inputs

Matthew Beardsworth

ABSTRACT

With high power Class-D audio amplifiers, layout is often critical for achieving maximum power and optimal performance. For this reason, a ground plane on two layers is recommended to provide a solid ground reference for the amplifier and to minimize ground voltage differentials across the die of the monolithic amplifier. However, as found with the TPA32xx family of amplifiers, referencing the analog input grounds directly to the ground plane can cause issues, especially when using single ended op-amps.

NOTE: This applications report discusses the grounding recommendations for analog inputs only. It is always recommended to use a ground plane for high power and switching nodes with all Class-D amplifiers.

Contents

1	Single Ended to Differential Input Stage	2
2	Input Stage with Ground Plane	3
	2.1 Testing Ground Plane Configuration	4
	2.2 Ground Plane Results	4
3	Input Stage with Star Ground	5
	3.1 Testing Star Ground Configuration	5
4	TPA32xx Ground Pin Reference.....	6

List of Figures

1	Cost Effective SE to Diff Input Stage	2
2	SE to Diff Input Stage Ground Plane Noise.....	3
3	TPA3244 THD+N vs Power 1 KHz Ground Plane	4
4	TPA3244 THD+N vs Power 100 Hz Ground Plane	4
5	TPA3245 THD+N vs Power 100 Hz Ground Plane	4
6	SE to Diff Input Stage Star Ground	5
7	TPA3244 THD+N vs Power 100 Hz Star Ground	5

1 Single Ended to Differential Input Stage

Figure 1 shows the basic setup for a Single-Ended (SE) to Differential (Diff) input stage used with the TPA32xx amplifier. In this use case, the amplifier is configured for BTL output and requires “Input_A” and “Input_B” to be driven differentially. A pair of inverting Op-amps is used where the Op-amp gain is set to -1 . By cascading the operational-amplifiers as shown, the analog signal from the RCA jack labeled “SE Input” appears on both “Input_A” and “Input_B” of the TPA32xx amplifier out of phase with each other.

These operational-amplifiers also run from a single 12 V supply rail to reduce cost. In order to pass analog signals that swing below ground, the operational-amplifiers are biased to the mid rail (6 V) using a resistor divider and filter. Then DC blocking capacitors are used to isolate the Op-amp bias voltage from a ground referenced analog input.

This cost effective SE to Diff converter works quite well; however, since this design is not using a truly differential operational-amplifier stage, there will always be some imbalance between “Input_A” and “Input_B” with this configuration and less than ideal common mode (CM) rejection.

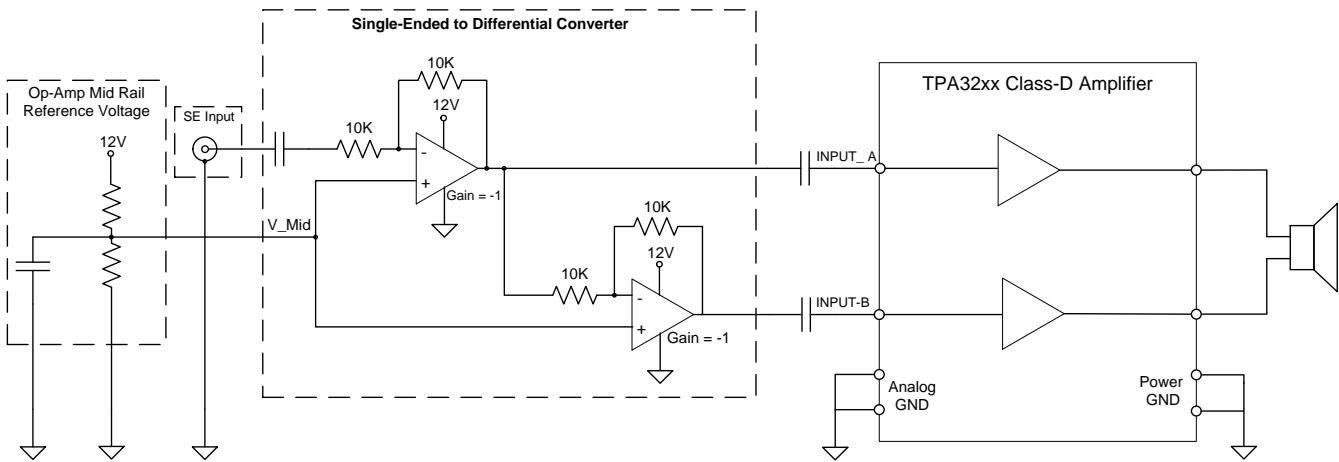

Copyright © 2016, Texas Instruments Incorporated

Note: Only one channel of TPA32xx Class-D Amplifier is shown

Figure 1. Cost Effective SE to Diff Input Stage

2 Input Stage with Ground Plane

Now suppose that all of the ground points for the input stage are tied to the ground plane at the most convenient locations, as typically done in PCB layout (Figure 2).

At high output power, the ground plane used for the TPA32xx amplifier will start to see heavy current flow and switching noise. This is generally worse at lower audio frequencies where the sustained amplitude of the audio signal peaks is longer when compared to higher frequency signals. This can cause lots of noise on the ground plane.

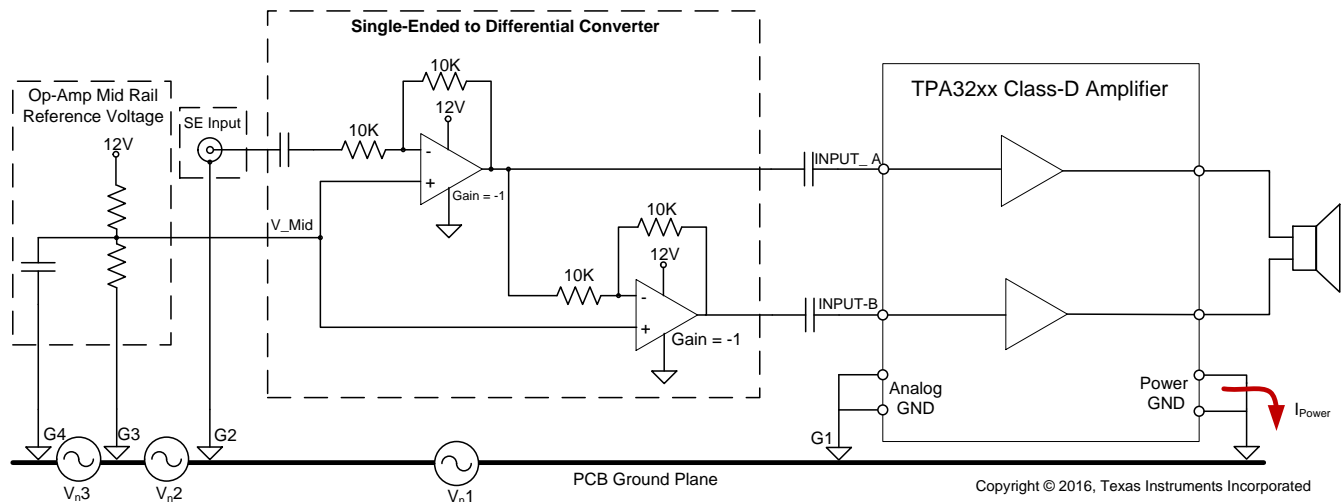

Figure 2. SE to Diff Input Stage Ground Plane Noise

Due to the heavy current flow into the ground plane as represented by the arrow " I_{power} " noise voltages V_{n1} , V_{n2} , and V_{n3} develop across the ground plane. Therefore, the ground nodes for the input stage G2, G3, and G4 will all be at different potentials relative to the TPA32xx amplifier analog ground reference G1.

Since our Op-amp input stage is not truly differential with poor CM rejection, signal imbalance is inevitable. It is likely that a differential noise voltage due to V_{n1} , V_{n2} , and V_{n3} develop between "Input_A" and "Input_B" and is amplified by the TPA32xx amplifier.

This results in degraded low frequency audio performance.

2.1 Testing Ground Plane Configuration

THD+N vs output power of the TPA3244 amplifier was tested using the SE to Diff input stage where the signal grounds were tied to the ground plane of the PCB as shown in Figure 2. The TPA3244 was setup to run stereo channels in BTL with 4 Ω loads, so our input stage is copied for the other channel.

In Figure 3, the THD+N audio performance looks quite good at 1 KHz. However, as shown by Figure 4, at 100 Hz the THD+N is quite different between channels.

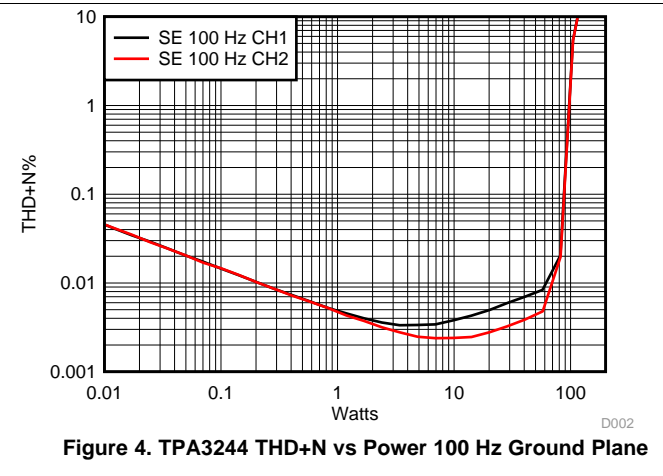
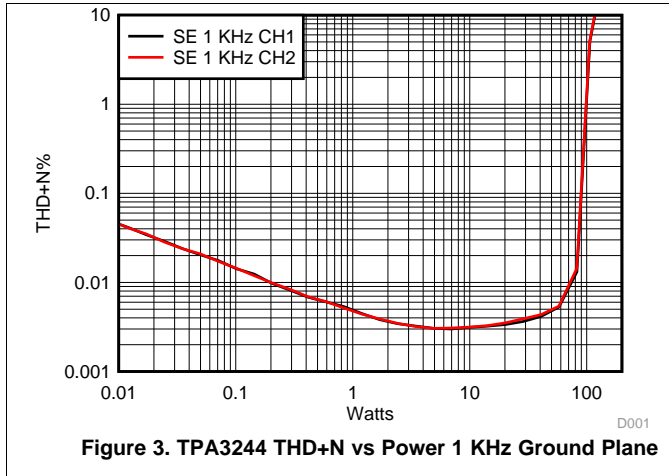

A PCB with the TPA3245 was also tested at 100 Hz and the results were even worse. Channel 1 has a THD+N of 0.013% whereas Channel 2 is 0.0049% at 20 Watts of output power.

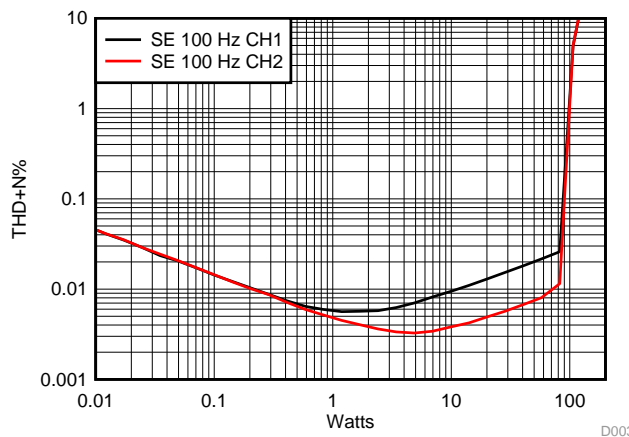

2.2 Ground Plane Results

The reason for different THD+N results between stereo channels at 100 Hz is simply ground plane noise. At low audio frequencies and high output power, ground noise is being injected into our SE to Diff analog input stage and reducing performance. However since we cannot control the currents in the ground plane and it is unlikely that the layout is 100% symmetric, the SE to Diff input stage of Channel 1 has been affected more by our ground noise.

3 Input Stage with Star Ground

To fix this issue, G2, G3, and G4 input stage ground nodes were connected with separate traces directly to the TPA32xx amplifier analog ground reference, G1. With this star ground connection scheme, G1 G2 G3 and G4 are well coupled and share the same ground potential. Therefore, no noise voltage can be developed between the input stage grounds and the TPA32xx analog ground. Figure 6 shows this connection scheme.

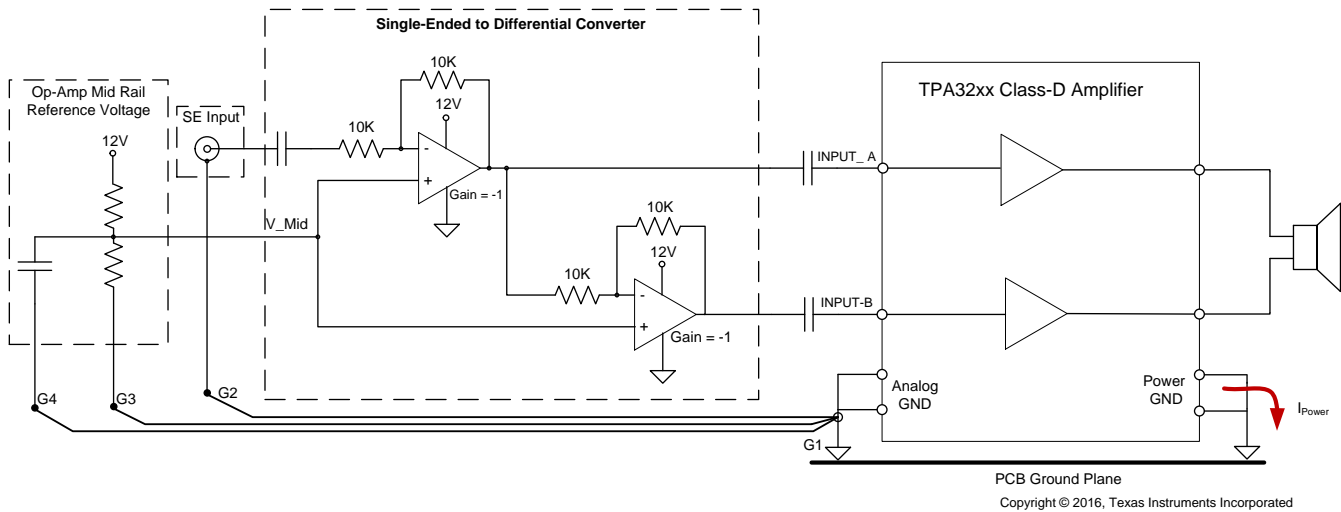

Figure 6. SE to Diff Input Stage Star Ground

NOTE: The supply grounds of the two operational-amplifiers are not shown to connect to specific point on the grounding scheme. The high PSRR offered by the op-amp means that ground noise on the supply pins will have little impact on the audio performance. Generally it is acceptable to tie the operational-amplifier supply ground to a convenient location.

3.1 Testing Star Ground Configuration

Using this star ground topology of Figure 7, the THD+N vs output power of the TPA3244 amplifier was again tested by running 2 channels in BTL with 4 Ω loads at 100 Hz.

Not only is the amplifier channel performance now matched, but the overall THD+N has improved. Ground noise is no longer affecting our input stage.

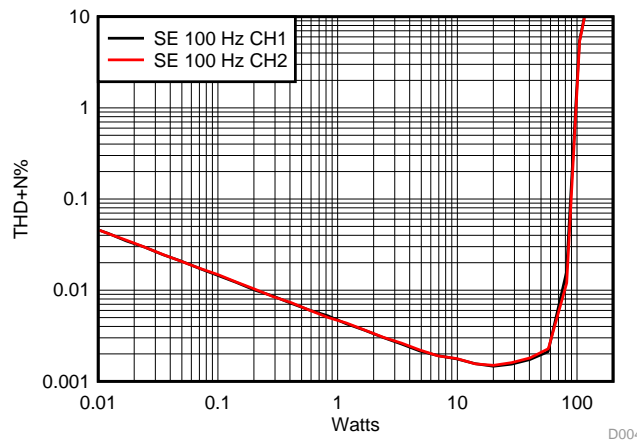

Figure 7. TPA3244 THD+N vs Power 100 Hz Star Ground

4 TPA32xx Ground Pin Reference

For reference, the pinout of the analog and power ground pins on the TPA32xx devices are listed in [Table 1](#).

Table 1. TPA32xx Ground Pins

TPA32xx Class-D Amplifier Ground Pins		
Amplifier	Analog Ground Pins	Power Ground Pins
TPA3244	10, 11	25, 26, 33, 34, 41, 42
TPA3245	12, 13	25, 26, 33, 34, 41, 42
TPA3250	10, 11	25, 26, 33, 34, 41, 42
TPA3251	12, 13	25, 26, 33, 34, 41, 42
TPA3255	12, 13	25, 26, 33, 34, 41, 42

IMPORTANT NOTICE

Texas Instruments Incorporated and its subsidiaries (TI) reserve the right to make corrections, enhancements, improvements and other changes to its semiconductor products and services per JESD46, latest issue, and to discontinue any product or service per JESD48, latest issue. Buyers should obtain the latest relevant information before placing orders and should verify that such information is current and complete. All semiconductor products (also referred to herein as "components") are sold subject to TI's terms and conditions of sale supplied at the time of order acknowledgment.

TI warrants performance of its components to the specifications applicable at the time of sale, in accordance with the warranty in TI's terms and conditions of sale of semiconductor products. Testing and other quality control techniques are used to the extent TI deems necessary to support this warranty. Except where mandated by applicable law, testing of all parameters of each component is not necessarily performed.

TI assumes no liability for applications assistance or the design of Buyers' products. Buyers are responsible for their products and applications using TI components. To minimize the risks associated with Buyers' products and applications, Buyers should provide adequate design and operating safeguards.

TI does not warrant or represent that any license, either express or implied, is granted under any patent right, copyright, mask work right, or other intellectual property right relating to any combination, machine, or process in which TI components or services are used. Information published by TI regarding third-party products or services does not constitute a license to use such products or services or a warranty or endorsement thereof. Use of such information may require a license from a third party under the patents or other intellectual property of the third party, or a license from TI under the patents or other intellectual property of TI.

Reproduction of significant portions of TI information in TI data books or data sheets is permissible only if reproduction is without alteration and is accompanied by all associated warranties, conditions, limitations, and notices. TI is not responsible or liable for such altered documentation. Information of third parties may be subject to additional restrictions.

Resale of TI components or services with statements different from or beyond the parameters stated by TI for that component or service voids all express and any implied warranties for the associated TI component or service and is an unfair and deceptive business practice. TI is not responsible or liable for any such statements.

Buyer acknowledges and agrees that it is solely responsible for compliance with all legal, regulatory and safety-related requirements concerning its products, and any use of TI components in its applications, notwithstanding any applications-related information or support that may be provided by TI. Buyer represents and agrees that it has all the necessary expertise to create and implement safeguards which anticipate dangerous consequences of failures, monitor failures and their consequences, lessen the likelihood of failures that might cause harm and take appropriate remedial actions. Buyer will fully indemnify TI and its representatives against any damages arising out of the use of any TI components in safety-critical applications.

In some cases, TI components may be promoted specifically to facilitate safety-related applications. With such components, TI's goal is to help enable customers to design and create their own end-product solutions that meet applicable functional safety standards and requirements. Nonetheless, such components are subject to these terms.

No TI components are authorized for use in FDA Class III (or similar life-critical medical equipment) unless authorized officers of the parties have executed a special agreement specifically governing such use.

Only those TI components which TI has specifically designated as military grade or "enhanced plastic" are designed and intended for use in military/aerospace applications or environments. Buyer acknowledges and agrees that any military or aerospace use of TI components which have **not** been so designated is solely at the Buyer's risk, and that Buyer is solely responsible for compliance with all legal and regulatory requirements in connection with such use.

TI has specifically designated certain components as meeting ISO/TS16949 requirements, mainly for automotive use. In any case of use of non-designated products, TI will not be responsible for any failure to meet ISO/TS16949.

Products

Audio	www.ti.com/audio
Amplifiers	amplifier.ti.com
Data Converters	dataconverter.ti.com
DLP® Products	www.dlp.com
DSP	dsp.ti.com
Clocks and Timers	www.ti.com/clocks
Interface	interface.ti.com
Logic	logic.ti.com
Power Mgmt	power.ti.com
Microcontrollers	microcontroller.ti.com
RFID	www.ti-rfid.com
OMAP Applications Processors	www.ti.com/omap
Wireless Connectivity	www.ti.com/wirelessconnectivity

Applications

Automotive and Transportation	www.ti.com/automotive
Communications and Telecom	www.ti.com/communications
Computers and Peripherals	www.ti.com/computers
Consumer Electronics	www.ti.com/consumer-apps
Energy and Lighting	www.ti.com/energy
Industrial	www.ti.com/industrial
Medical	www.ti.com/medical
Security	www.ti.com/security
Space, Avionics and Defense	www.ti.com/space-avionics-defense
Video and Imaging	www.ti.com/video

TI E2E Community

e2e.ti.com