

Exicon Lateral MOSFETs

These audio devices are capable of very high standards of amplification, with low distortion and very fast slew rates. They are free from secondary breakdown and thermal runaway and extremely reliable.

Ease of driving results in fewer components in the audio path promoting cost savings and an improvement in sound quality.

Foreword

Part 1 covers the practical design considerations when using Exicon MOSFETs.

Part 2 describes two amplifier circuits designed to provide good sonic qualities.

The first on page 4 is the simpler and cheaper circuit which can drive up to two pairs of MOSFETs. The distortion figures are good and it clips cleanly.

The second, on page 5, uses an integrated circuit to give high levels of performance at moderate cost. The total harmonic distortion is less than 0.01% in the low to mid frequency range (20Hz to 4kHz) and there is only a small rise at higher frequencies which is not significant when you consider the resulting harmonic frequencies.

Applications

- High power public address
- High fidelity amplifiers
- Musical instruments/stage
also
- Industrial power supplies
- Linear motor drives
- Inverters
- Regulators

These high performance amplifier modules described on page 5 are available for evaluation and development purposes.

TO247/TO264
Demo board

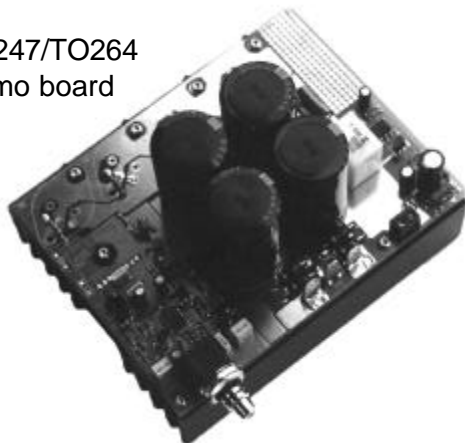

Features

- Output power: 100W to over 500W* into 4Ω
- Total harmonic distortion <0.01% @ 1 kHz
- Slew rate >100V/μs
- Power bandwidth >100kHz
- Rugged and reliable

* With additional heatsink

TO3
Demo board

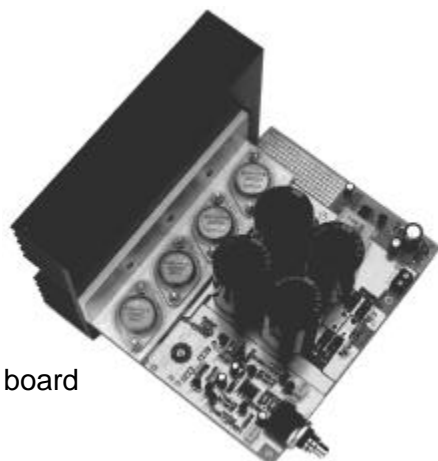

Application Information for Exicon MOSFETs:

Part 1. Practical design considerations.

Stability :

Lateral MOSFETs are extremely fast, and to achieve stable and oscillation free operation a number of design factors must be considered.

(a) Layout.

The devices should be located as close to each other as thermal considerations allow.

The source connections should be short and direct and as thick as possible.

When paralleling devices for higher output powers it is very important to reduce the inductance between the device source connections. The most effective method of achieving this is to mount the devices directly to a common heatsink bracket, and then insulating this from the main heatsink. As the source is bonded to the case, the inter-device inductance is reduced below the point that will cause problems. A secondary benefit of this method of mounting is that there is no need for the source terminals to be connected via the PCB, which simplifies the layout.

(b) Gate resistors.

The upper limit of the frequency response is determined mainly by the speed at which the gate electrode voltage can be varied. The internal gate resistance of several ohms in conjunction with the gate capacitance forms a low pass filter. The MOSFETs are still capable of operating at several megahertz in source follower mode, and can oscillate at these frequencies if sufficient inductance is present in the gate lead.

External gate resistors are added to reduce the gain of the device at high frequencies to a point where there is insufficient gain to allow oscillation. This resistance must be located as near to the gate connection as possible to provide maximum damping. A resistor must be used for each device. Ferrite beads can also be used to provide damping to the MOSFETs gate circuit.

(c) Device type.

P channel devices have approximately twice the capacitance of N channel devices. For single pair applications this does not usually cause any problems, (as most problems are compensated for by the high idle current) but where several devices are paralleled the speeds will need to be matched to reduce the possibility of cross conduction and crossover distortion at high frequencies. This occurs in the crossover region of operation when one set of devices switches faster than the other.

Cross conduction occurs when the fast devices turn on before the slow devices turn off, and crossover distortion occurs on the other transition when the fast devices turn off before the slow devices turn on. The ruggedness of the devices combined with the short duration of the cross conduction prevent device failure, but the sound quality can suffer.

Two options are available to prevent the problem. Lower value gate resistors can be used for the P channel devices, or equalisation capacitors can be added to the N channel devices. Either option works, but as the gate resistor solution has a lower component count it is more cost effective.

(d) Component selection.

Certain components must be carefully selected to avoid stability problems. The Zoebel network resistor should be a carbon or metal film type, definitely not wirewound. For higher powers two or more resistors can be paralleled to achieve the required dissipation, or use thick film power types. The capacitor should be a stacked film type, preferably with a polypropylene dielectric. Avoid ceramic capacitors unless NPO or Low K material, as their characteristics change too much with temperature, which can lead to stability problems. The gate resistors can be any film types. If using ferrite beads for gate suppression, use a material with high losses at low frequencies.

Thermal considerations:

General

The choice of heat sink type and mounting depends on a number of factors. For instance, a stage or public address amplifier may have to run near to full power for many hours in high ambient temperatures where as a domestic hi-fi amplifier will rarely reach full output.

(a) Device dissipation

The 'on' resistance of lateral MOSFETs increases with temperature. This contributes to their ruggedness but reduces the available output power at elevated temperatures. If an amplifier is to deliver its full rated output for extended periods then the heatsinking must be sufficient to keep the MOSFETs at a temperature where the losses due to heat generation in the drain-source resistance is not great. In some instances it may be more economical to add extra devices over the minimum required in order to reduce the heatsink and power supply requirements.

(b) Efficiency

The typical efficiency of a lateral MOSFETs output stage will be between 65 and 70%. This translates to a dissipation of 43 - 54 watts per 100 watts of output power. For domestic HiFi amplifiers the idle dissipation can also be significant. If the heatsinks are exposed then the temperature rise may need checking to ensure compliance with safety regulations.

(c) Reliability

The reliability of any electronic circuit is inversely proportional to temperature. In semiconductors, (particularly those encased in plastic) the migration of impurities significantly increases above 110°C reducing their useful life.

A good rule of thumb when using these MOSFETs is to set a maximum operational case temperature of 110°C. This allows sufficient margin for case to sink thermal resistance, and should yield good long term reliability, and a generous safety margin for overload conditions.

In most applications, an efficiency figure of 65% can be used for determining steady state heatsink requirements, i.e. the losses in the MOSFETs will be approximately half the output power (P). The heatsink thermal resistance (θ_H) can be calculated using this figure in conjunction with the ambient temperature (T) and the maximum heatsink temperature (H_{max}).

$$\theta_H = \frac{H_{max} - T}{0.5 P} \text{ } ^\circ\text{C/W}$$

For an amplifier with 100 watts (RMS) output power in an ambient temperature of 25°C and a maximum allowable heatsink temperature of 100°C the heatsink thermal resistance will be:

$$\frac{100 - 25}{0.5 \times 100} = \frac{75}{50} = 1.5^\circ\text{C/W}$$

Drive requirements:

The gate circuit presents a capacitive load to the drive circuit. In source follower mode there is also the problem of a voltage gain which varies from effectively 1 at low levels to around 0.8 - 0.9 at full output. This value is also affected by the loading, and in conjunction with the capacitive input, places different demands on the drive circuit compared to a bipolar output stage.

Separate drive rails:

The gate - source voltage of a MOSFET is considerably larger than that of a bipolar output device, and some improvement in efficiency can be obtained in certain instances by powering the driver circuitry from a higher supply voltage, generally 4 - 5 volts higher than the main rails. This provides full gate drive to the output devices, and ensures they are fully turned on at the peak of the waveform. Care must be taken with this approach, to ensure that the gate-source voltage is not exceeded (+/-14V). Although the integral zener diode offers some protection to the gate, external zeners should be fitted for further protection. (typically 6.2V, 1.3W)

With the circuits described later, and the traditional drive circuit, the benefits of extra drive rails will only be realised if the drain - source voltage at the peak output current is less than 6 volts. This is because these drive circuits will swing to within 1 - 2 volts of the supply rail (as they are essentially unloaded), and the MOSFETs are fully on with 6 - 7 volts of gate drive. Any benefits to be had from extra driver supplies are likely to be worthwhile only if the output devices are carrying less than 4 amps peak per device, or the drive circuitry peak output is more than 2 volts below the supply rail.

It is also important to test for drive circuitry overloading under light clipping. The extra voltage rails can cause the drive circuit to hang up (from the lack of feedback), while recovering and this is sonically unpleasant.

Some sonic benefit can be gained by powering some driver circuits from a separate rail. This is especially noticeable if the driver circuit has poor power supply rejection.

Part 2. Circuit Designs

Circuit 1 Transconductance amp.

Circuit operation:

The input pair provide differential gain, and drives two PNP devices. One provides 'pull up' current for driving the MOSFETs, and the other is connected as a current mirror. This drives an NPN device on the negative rail and provides 'pull down' current. Biasing can be achieved by a resistor / thermistor combination, or a Vbe multiplier using a germanium device.

The hfe of the driver devices must be high to avoid loading the differential pair. Closed loop gain should be limited to around 50 as the open loop gain is not particularly high. This circuit can be silently muted by reducing the current through the current source. Clipping is clean with no overhang on the trailing edge. The sound quality is clean and detailed.

Circuit 1. Transconductance amp.

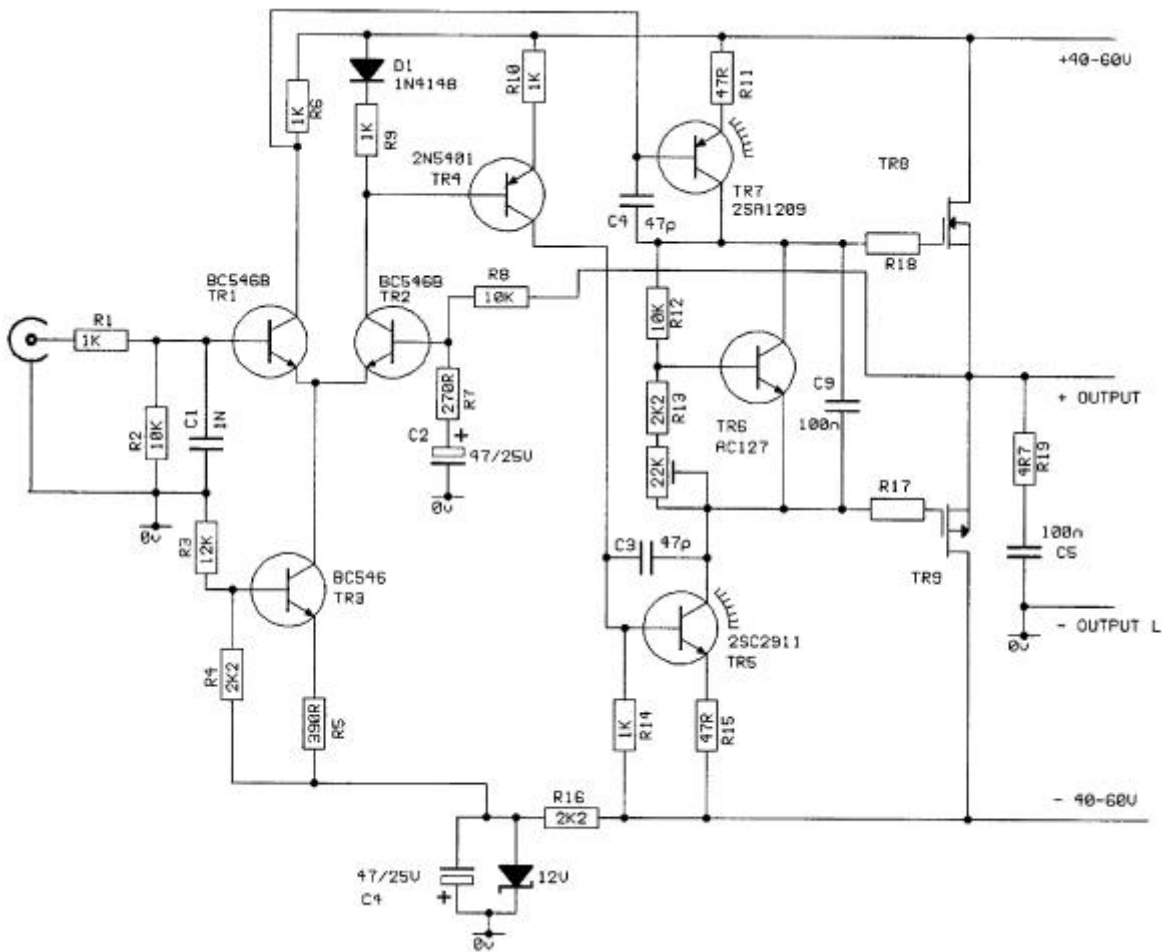

Circuit 2. Op amp based current mode driver.

This design uses a high performance audio op amp to provide the gain for a current feedback mode power amplifier and is the basis for the Amplifier Modules shown on page 1.

The op amp drives a low impedance load, and the rail currents of the op amp are first voltage translated by TR1 and TR4, then current inverted by the two Wilson current mirrors TR2 - 3 and TR5 - 6. This provides a differential current drive to the buffer stage TR8 - 11. Diodes D2 and D5 prevent saturation of the current mirrors. TR7 provides temperature compensated bias control.

The feedback is taken to the output of the op amp. The op amp cannot draw enough current from the current mirrors to provide the necessary voltage on the load resistance at its output terminal. By drawing current through the supply pins the voltage at the power amplifier output will rise to the point where current through the feedback resistance will create the required voltage at the output of the op amp.

The drive circuit can provide full output (150 Vp-p) at over 100 kHz while driving 12 pairs of devices. The maximum rail voltage is limited by the voltage ratings of the drive transistors. By changing the driver transistors for higher voltage types, rail voltages of +/- 100V can be used to drive the 200V MOSFET devices. If 300V transistors are used, then the circuit will be capable of driving the Profusion range of 250V MOSFETs

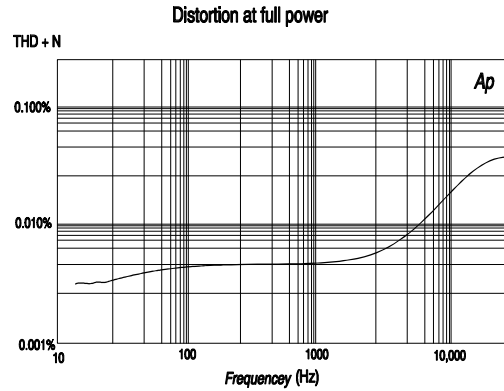

Circuit 2. Op amp based current mode driver.

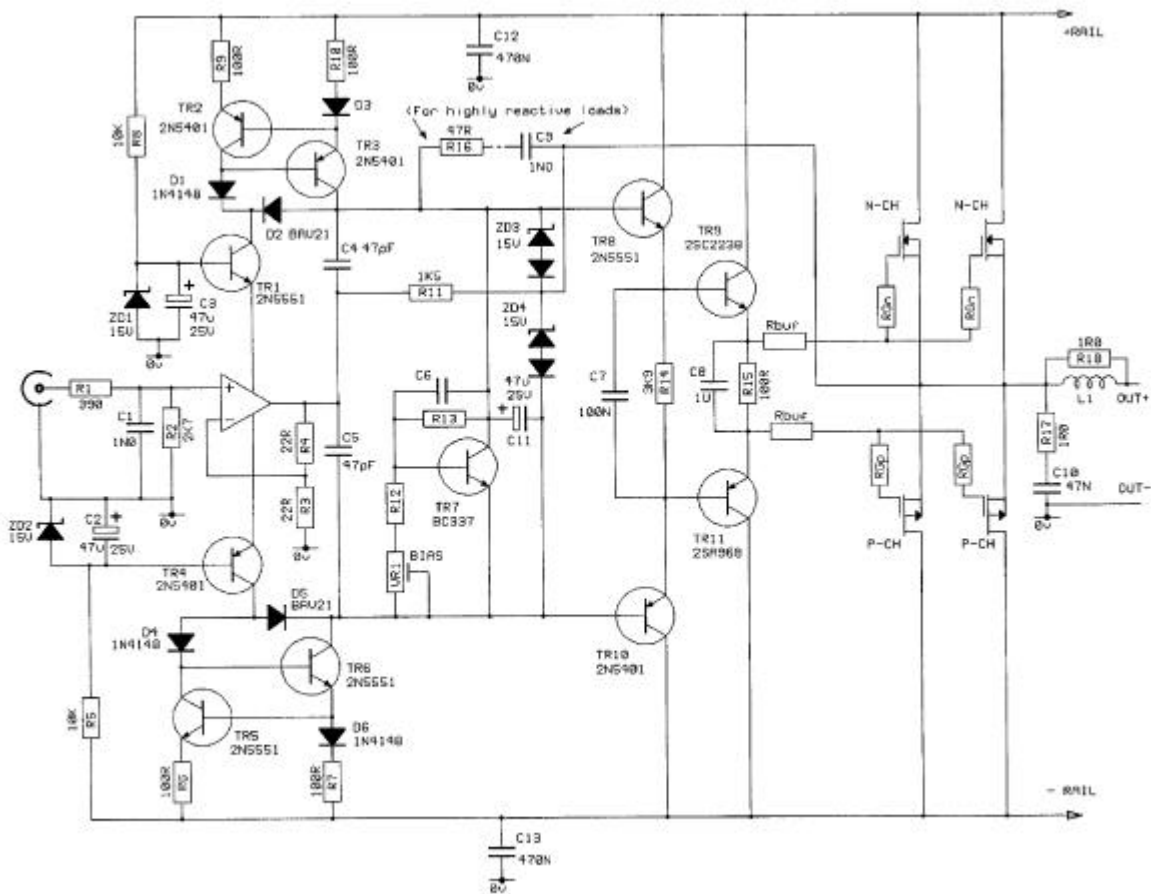

Most components are not particularly critical, however the following should be taken into consideration:

1. Use good quality transistors in the high voltage locations. Cheap devices often have poor gain, and can fail prematurely.
2. The bypass capacitors on the driver rails should be low ESR types. This includes the zener bypass capacitors
3. The Zoebel network resistor must be non inductive, i.e. a power film type. The capacitor should have a polypropylene dielectric, especially if high frequency signals at high amplitude are to be handled.
4. The amplifier cannot be more linear than its feedback network. Use good quality metal film resistors for R3,R4 and R11. R11 can dissipate significant amounts of power at full sinewave output. Several 0.6W 1% metal film resistors in parallel will provide adequate dissipation for most applications with good gain accuracy.
5. D2 and D5 see almost the full rail to rail voltage. These must be very fast and high voltage types to prevent breakdown. The recommended part BAV21 is inexpensive, and works well. Don't replace it with a 1N4148 unless the supply rails are less than +/- 50V.

Component substitution:

The circuit as shown is rated for +/- 80 volt rails. By substituting different drive transistors, the rails can be increased up to +/-100 volts for the 200V MOSFETs.

+/- 80v	+/- 100v
2N5401	MPSA 92
2N5551	MPSA 42
2SA1306/968	MJE 350
2SC3298/2238	MJE 340

The higher voltage devices have lower gain and speed, and the performance of the circuit will reduce slightly at high frequency. If driving a large number of MOSFETs at high voltage, it may be advisable to parallel two or more of the MJE devices to ensure reliability. Use a 22 ohm ballast resistor in series with the emitter of each device to ensure current sharing. Mount the drivers on a heatsink to keep the junction temperature as low as possible.

The gain can be varied by changing R11, but this should be limited to a range of 560 ohms to 2k2 to maintain stability. The gain can be further varied by adjusting the op amp gain via R4. The op amp gain can be increased to 10 before its bandwidth drops below that of the associated driver circuit.

Bias for the output stage is controlled by VR1.

Bias adjustment can be made by inserting an ammeter in one of the rails, or by monitoring the amplifier output at high frequencies with a sensitive distortion analyser. The bias can then be adjusted to remove the crossover blips on the distortion trace.

Muting

This circuit has a considerable turn on thump. This can be eliminated by conventional relay muting in the output line or by slugging the drive nodes before the emitter follower. C11 is replaced by two series connected 1000µF electrolytics, and the centre tap of these capacitors is connected via a 100 ohm resistor to a relay contact. The other relay contact is grounded. When the relay contacts are closed, the input to the drive circuitry is effectively shorted at audio frequencies. As this is a relatively high impedance node, the turn-on thump is greatly attenuated.

A second relay contact must short the input of the op amp to ground. This prevents the op amp pulling large currents in an attempt to drive the output, should a signal be applied to its input when the amplifier is muted.

The inductor in the output line isolates the amplifier from capacitive loads. The required inductance is small, <1µH, and an air cored coil made from 10 turns of 1.3 mm wire with an internal diameter of 5mm works well. The 1 ohm resistor reduces the Q factor of the inductor to prevent ringing on transients.

Power supply considerations.

The power supply should be capable of supplying the module with D.C. equivalent to 150% of the RMS output power.

The power supply capacitors should be at least 2,000µF per amp drawn from the supply rail. This will yield approx 1 volt p-p of ripple, which is a good compromise between cost and performance. For applications where the sound quality is of prime importance, the capacitance should be increased to 2 or 3 times this value.

The mains transformer should be sized according to expected usage. Hi-fi amplifiers use a transformer rated at approx 1.5 x the total output power (in VA). For a stage or P.A. amplifier the factor should be 2 - 2.5 times the output power.

Oversize power transformers will also enhance the sound quality.

The rectifier can be made from discrete diodes or a bridge rectifier. Remember that bridge output ratings are given at relatively low case temperatures, and should be rated accordingly. Leaded diodes dissipate much of their heat through their leads, and require large PCB lands to achieve their full ratings.

