

# SIMPLE 60W LOW DISTORTION AMPLIFIER MODULE

---

The popularity of our first 50 W 'universal' amplifier modules has been very high since they were published two and a half years ago. Since that time the state of the art has moved on. This project, designed by Phil Wait from an original circuit by Trevor Marshall, is intended to replace the ETI 480 and features simpler mechanical construction, low distortion (particularly TID) and generally better performance.

---

MANY DIFFERENT amplifier circuits have appeared in popular electronics magazines over the years. The most popular audio projects we have ever published were the 100 watt guitar amp. (ETI 413, published in December 72 and still going strong!), the 422 amp. and the 480 series of power amp. modules.

While these seemed to have satisfied a large demand, our attention has been drawn to the need for something a 'step up' from there — something that approaches the current 'state of the art' for hi-fi equipment. Lower distortion than previously obtained, better bass performance and flexibility was the message we received from reader's letters and kit and component suppliers ("Why don't you . . .", "What I'd like to see . . .", "I need a . . .", etc.).

Late last year we set in motion the 'wheels' necessary to bring this project into fruition. Our major design hurdles were cleared with room to spare with the assistance of talented West Australian designer, Trevor Marshall.

A great many factors place sometimes quite severe constraints on project design — particularly component availability and ease of construction; not forgetting that this design had to perform significantly better than those that came before it.

There is clearly little point in describing a project that includes components that are impossible to get or one that is difficult to construct.

A strong point that came across to us from reader feedback and from the popularity of our 480 series of amplifiers was that constructors favoured a modular concept. It seems that the days of the single-board stereo amplifier project have come and gone.

This power amplifier offers a significant improvement in specifications

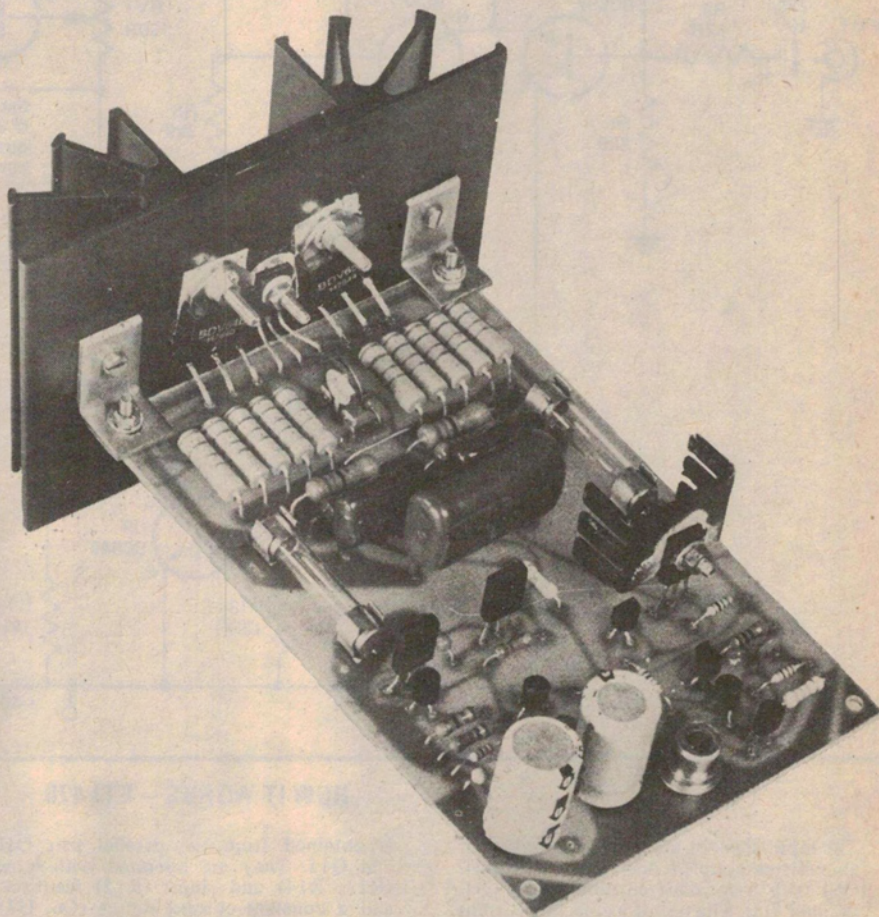

and ease of construction over most kit amplifiers offered to date. It has been designed particularly with low transient intermodulation distortion in mind.

Although a difficult parameter to measure, transient intermodulation distortion is an inherent characteristic of many amplifier designs — especially those which incorporate large amounts

of feedback to even out frequency response and reduce harmonic distortion. The heavy feedback 'school' of design produces an impressive list of specifications — but the difference *to the ear* between such an amplifier and one designed for low TID has to be heard to be believed.

# 60W AMPLIFIER MODULE

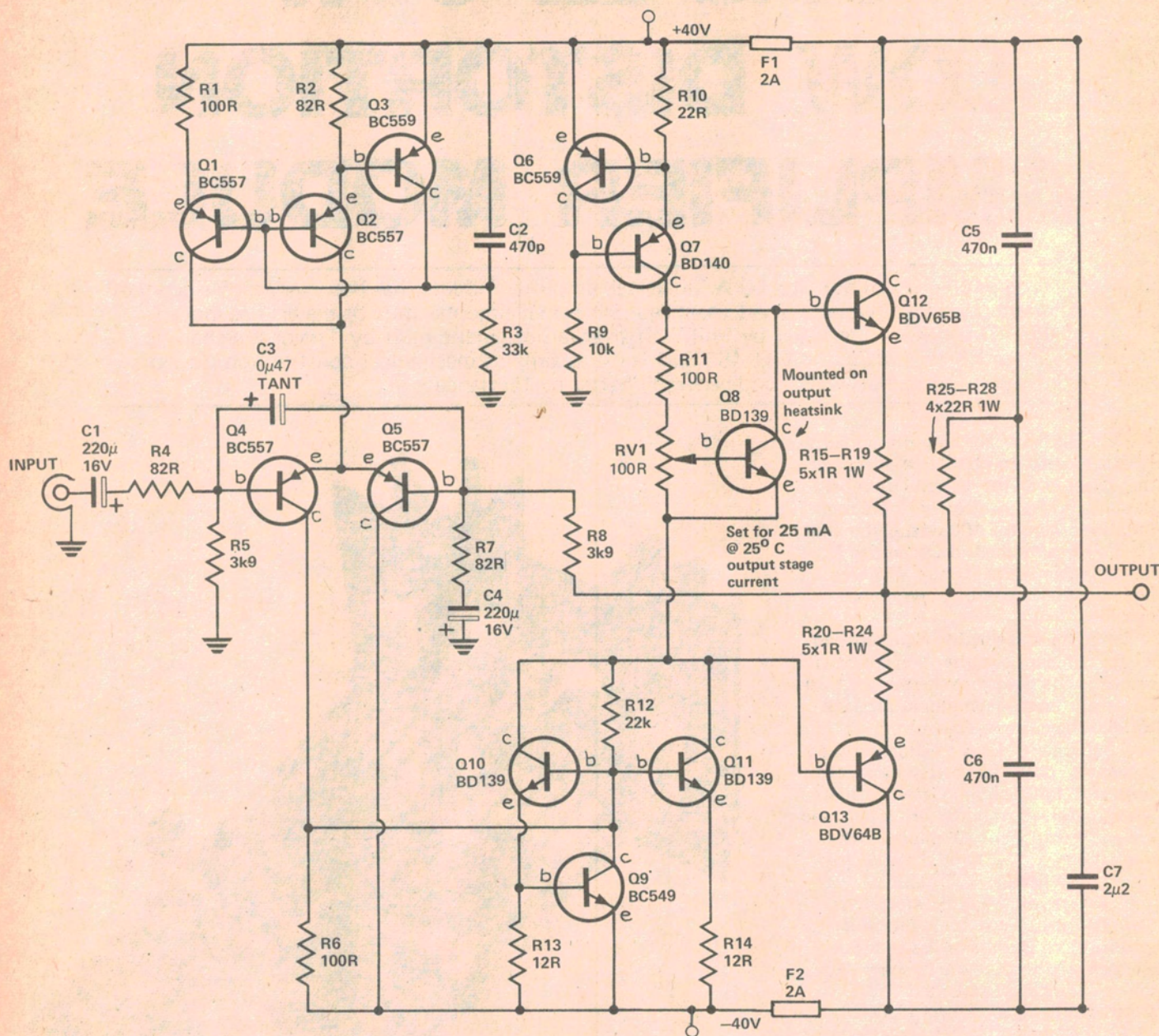

## HOW IT WORKS - ETI 470

The input stage of the amplifier consists of an emitter coupled differential pair (Q4, Q5) with a constant current source (Q1, Q2 and Q3). The use of a constant current source reduces distortion, as well as the possibility of high frequency oscillation and prevents any ripple on the positive supply from unduly affecting the input stage. Unequal emitter resistors (R1, R2) allow the currents in Q4 and Q5 to be optimised. Input lag compensation is provided by C3, limiting the slew rate of the amplifier to reduce high frequency intermodulation. The gain of the differential pair, driving Q10 and Q11, is very low.

Almost all the gain of the amplifier

is obtained from the parallel pair Q10 and Q11. They are operated with series (R13, R14) and shunt (R12) feedback, and a constant current source (Q6, Q7). This results in a highly linear stage.

Q9 protects Q10 and Q11 from high peak currents or damage should a fault occur. When the current through R13 exceeds the safe limit, Q9 conducts and shorts out the drive to Q10 and Q11.

Bias from the output stage is set by RV1 and a shunt regulator (Q8). Q8 is mounted on the same heatsink as the output stages and stabilises the output bias current against heatsink temperature rise. Resistors R15-R24 in the emitters of the output Darlington, Q12 and Q13,

maintain operation in their safe region as well as reducing the chance of thermal run away.

Protection against ultrasonic oscillation is provided by C7 and the network consisting of R25-R28 and C5, C6.

Both DC and AC feedback is taken from the output, via R8, to the negative input of the differential pair, the amount of feedback being set by the ratio of R8 to R7. C4 increases the feedback, and therefore decreases the overall gain, at very low frequencies. The feedback also automatically holds the DC output voltage at close to zero volts.

## Choice of Power Supply

The design of the power supply can mean the success or failure of an otherwise well-designed amplifier. The supply voltage should be well-regulated, varying less than 10% from no load to full load, and be able to supply high peak currents.

However, if a voltage regulator is employed it too must be capable of delivering the very high peak currents occasionally demanded. This necessitates an expensive regulator device and large, expensive filter capacitors.

The alternative is to use a fairly large transformer and large value filter capacitors on a capacitor-input bridge rectifier. This is what we chose.

The circuit given here shows a power supply suitable for supplying a stereo amplifier using two of these modules. The filter capacitors C8 and C9 consist of two 2500  $\mu$ F, 50 volt electrolytic capacitors connected in parallel. This is the minimum we would recommend.

In general, the largest value filter capacitor one can afford is a good rule of thumb! *It has been suggested to us that values as high as 20 000 to 50 000  $\mu$ F makes an audible difference in performance.* (Watch the rectifier specifications though!).

Improved performance can be obtained for a modest increase in cost by having a separate supply for each channel module. This improves the regulation, reduces crosstalk and increases the amount of power available before output clipping commences.

The choice of transformer will determine power output. A 28-0-28 volt, 2 A transformer (Ferguson PF3577 or similar) will power a module to 60 watts (RMS) power output, while a 26-0-26 volt, 2 A type (e.g. Dick Smith M-0148 C-core) will permit 40 watts.

The power supply output should be limited to a peak DC voltage of about 40 volts (for 60 W output). A C-core transformer will generally improve the hum and noise output figures apart from having a reduced field, thereby reducing possible hum pickup problems.

If the amplifier module is to be used with a 4-ohm speaker system the supply voltage must be limited to about 30 volts maximum, otherwise the output devices will attempt to deliver over 100 watts followed by rapid self destruction!

Adventurous constructors may wish to try adding a second set of Darlington output devices, with their own emitter resistors as per the circuit, connected in parallel with the original pair. This combination may supply 100 watts or more into a four ohm speaker load. This technique is also recommended if you are contemplating driving highly

## ETI 470 SPECIFICATIONS

Power Output	60 watts into 8 ohms ( $\pm$ 40V supply)
Frequency Response	10 Hz to 100 kHz $\pm$ 0.5 dB
Input Sensitivity	500 mV rms for 60 W output
Hum and Noise	better than -110 dB on full output (dependent on power supply)
Feedback Ratio	35 dB
Distortion	at 1 kHz, 30 V p-p output into 8 ohms, Closed Loop 0.04 % (open loop 1 %)

**Stability:** The amplifier was found to be completely stable when operated into reactive loads consisting of R + C, L + C and pure L

**Intermodulation** (calculated values) . . . at 1kHz, 30 V p-p output into 8 ohms,  
3rd order . . . . . less than 0.015 %  
5th order . . . . . less than 0.0023 %  
(Intermodulation reduces with reduced power)

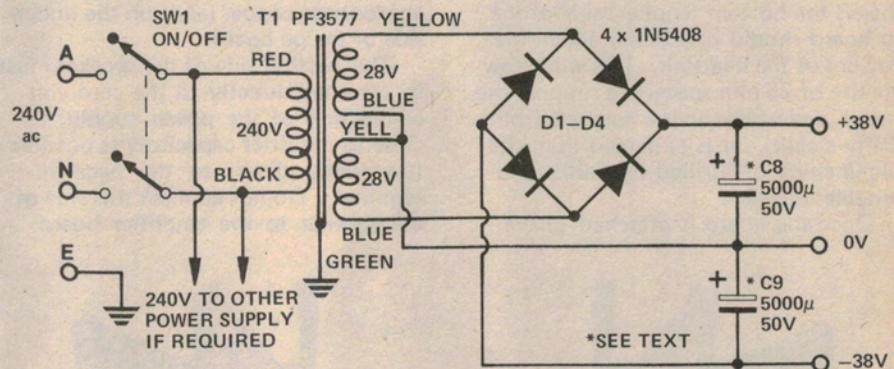

## WHY LOW TID?

Looking at the circuit and a quick glance at the specifications, there's little in the circuit that looks outstandingly different from others. So what makes this amplifier special?

The difference in concept that makes this amplifier unique is the use of a very linear, high gain driver stage (Q10, Q11), with a constant current source (Q6, Q7), so that the gain of *this* stage is dependent upon the input impedance of the output transistors. However, *their* input impedance is dependent upon their gain, and therefore *the gain of the amplifier stage is dependent solely upon the characteristics of the output devices.*

Series and shunt feedback is used with Q10 and Q11 which results in a highly linear stage with a very low input impedance (about 28 ohms). The gain of the differential pair when

fed into this low impedance is close to unity, so almost all the gain of the amplifier is concentrated in Q10 and Q11.

Provided the phase shifts in the differential pair and the gain stage are negligible the feedback loop is unconditionally stable.

There are two other design features which result in low TID.

The total open loop (feedback disconnected) distortion is only 1% at 30 V p-p output. So, very little feedback is necessary to reduce this to an acceptable level.

Protection of the output transistors is done by fuses, rather than electronically, and very high transient currents can be fed to the speaker without being affected by the (inevitably) non-linear impedance of an electronic protection circuit.

# 60W AMPLIFIER MODULE

reactive loads such as electrostatic loudspeakers.

## Construction

All components are mounted on a pc board — including the output devices. This method of construction is recommended. The module has been designed so that it is mechanically simple to assemble, much simpler than our ETI 480 module. Wiring errors are also avoided when a pc board is used.

Firstly, assemble and solder all the components on to the printed circuit board with the exception of Q12, Q13 (the output Darlington) and Q8. Carefully observe the polarity of all the electrolytic capacitors and orientation of the transistors.

The board is then mounted hard against the heatsink using small right-angle brackets. Be careful to avoid shorting the ends of the one ohm emitter resistors, R15-19 and R20-24, to the brackets.

If the module is to be mounted in a chassis the bottom (copper) side of the pc board should be 25 mm above the bottom of the heatsink. This will allow the use of 25 mm spacers to support the 'input' end of the board (furthest from the heatsink). It is expected that kits will include pre-drilled heatsinks and suitable brackets.

Once the board is attached to the

heatsink the output Darlington, Q12 and 13, and Q8 may be mounted. Insert them in the pc board and then press them back against the heatsink to form their leads to the right shape. Do not solder their leads yet.

Smear heat conducting compound on either side of the mica insulators (don't use too much though) and insert these between the devices and the heatsink.

Assemble the washers and mounting bolts for these, finally checking with an ohm meter that there is not a short circuit between the metal tags (collectors) of the devices and the heatsink.

The input connection to the module is via a single-hole mounting RCA socket. This is mounted directly on the pc board. The centre pin connects to C1 via a short length of tinned copper wire.

If this facility is not required the RCA socket may be omitted and a length of shielded cable soldered directly between C1 and the pc board common.

The power supply and speaker connections are soldered directly to the appropriate copper lands on the underside of the pc board.

The 'earthy' side of the speaker must be returned directly to the zero volt connection of the power supply, as close to the filter capacitors as possible (preferably direct to the negative terminal). Do not connect this side of the speaker to the amplifier board.

## PARTS LIST - ETI 470

**Resistors** all 1/4W, 5%, except R15-R28

R1 . . . . . 100R

R2 . . . . . 82R

R3 . . . . . 33k

R4 . . . . . 82R

R5 . . . . . 3k9

R6 . . . . . 100R

R7 . . . . . 82R

R8 . . . . . 3k9

R9 . . . . . 10k

R10 . . . . . 22R

R11 . . . . . 100R

R12 . . . . . 22k

R13, 14 . . . . . 12R

R15-R24 . . . . . 1R 1 watt

R25-R28 . . . . . 22R 1 watt

## Potentiometer

RV1 . . . . . 100R mini trimpot (vertical)

## Capacitors

C1 . . . . . 220 $\mu$  16V electro

C2 . . . . . 470p ceramic

C3 . . . . . 0 $\mu$ 47 35V tant

C4 . . . . . 220 $\mu$  16V electro

C5, 6 . . . . . 470n greencap

C7 . . . . . 2 $\mu$ 2 greencap

## Semiconductors

Q1, 2 . . . . . BC557, DS557

Q3 . . . . . BC559, DS559

Q4, 5 . . . . . BC557, DS557

Q6 . . . . . BC559, DS559

Q7 . . . . . BD140

Q8 . . . . . BD139

Q9 . . . . . BC549, DS549

Q10, 11 . . . . . BD139

Q12 . . . . . BDV65B

Q13 . . . . . BDV64B

## Miscellaneous

SK1 . . . . . single hole, panel mounting RCA socket.

F1, F2 . . . . . 2 Amp 3AG Fuses.

Fuse holders, heatsink for Q7, mica insulating kits (for Q8, Q12 and Q13), flat sided heatsink (75mm x 110mm), angle brackets, ETI 470 pcb.

## Parts List for Power Supply

D1-D4 . . . . . IN5404 or sim

C8, 9 . . . . . 5000 $\mu$  50V electro (see text)

SW1 . . . . . 240V Dpdt switch

T1 . . . . . 28V-0V-28V, 2 amp transformer Ferguson type PF3577 or similar (see text)

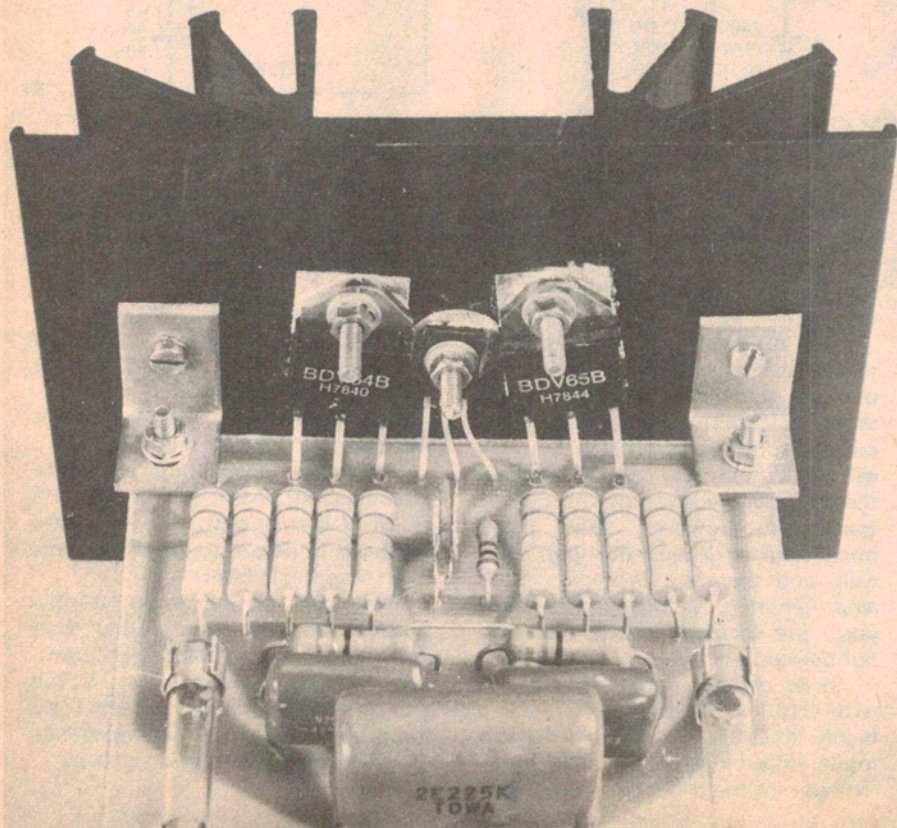

Left: closeup view of the output stage showing how the Darlington transistors are mounted and how the pc board attaches to the heatsink

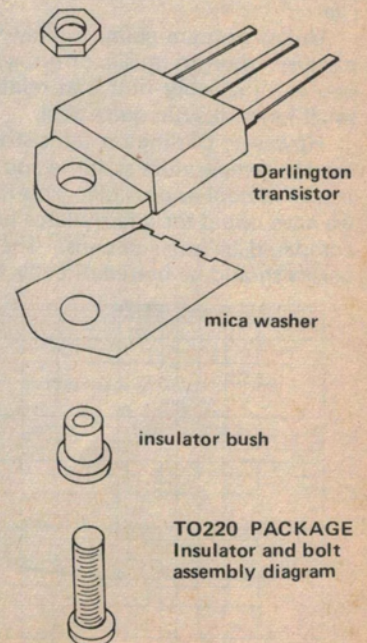
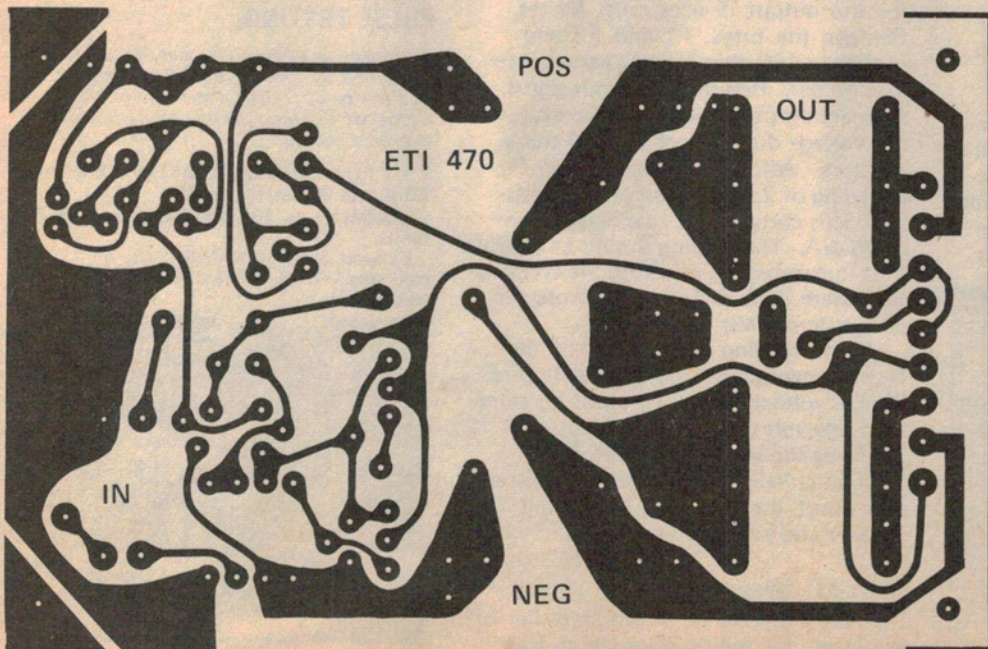
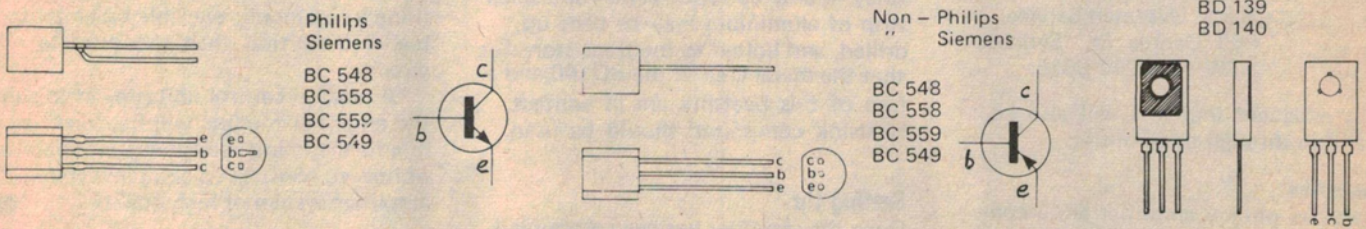
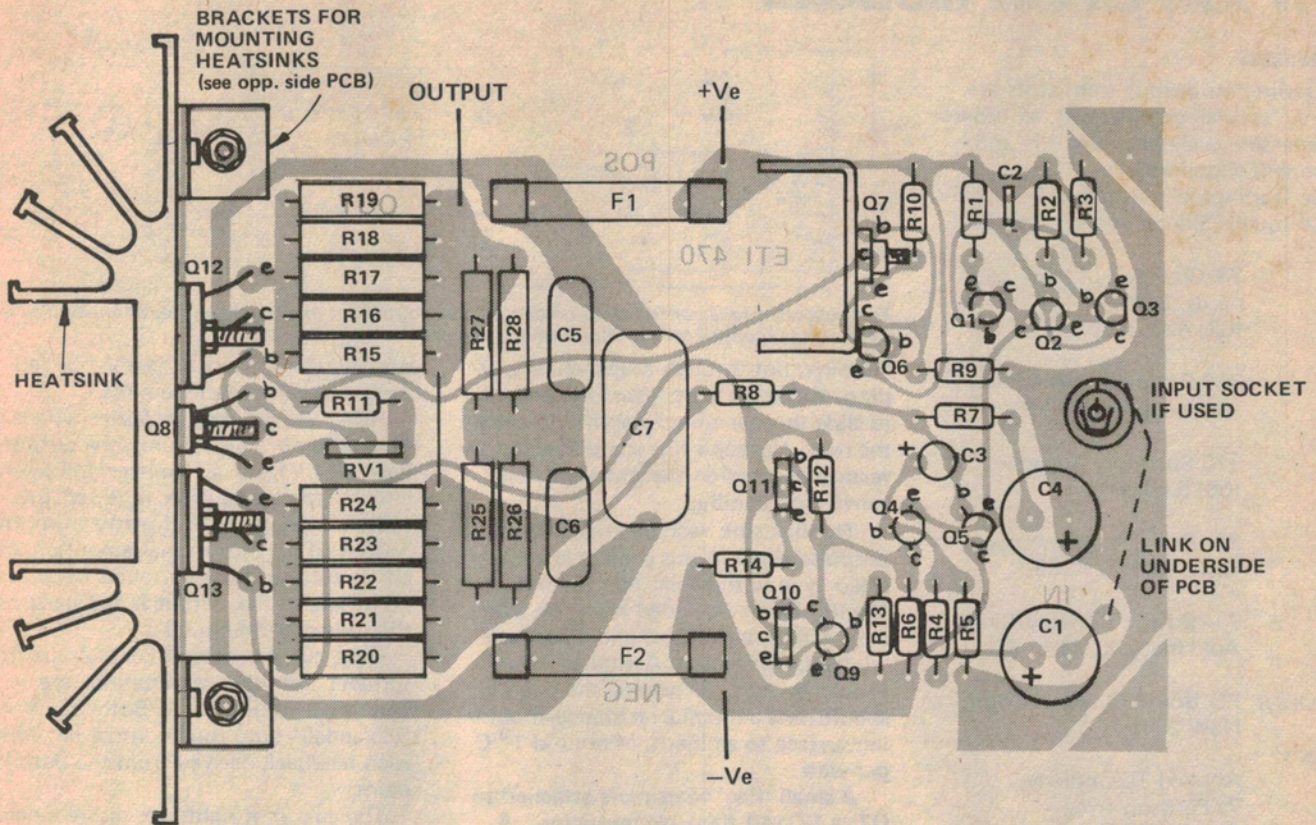

# 60W AMPLIFIER MODULE

## Components

The Darlington output transistors are the only 'special' components, all others are generally available from kit and component suppliers.

The Darlington transistors are available through Silicon Valley stores at:

23 Chandos St., St. Leonards, NSW;  
(02) 439 2965.

380 Bridge Rd., Richmond, VIC; (03) 429 4780.

170 Sturt St., Adelaide, SA  
(08) 51 4080.

22 Ross St., Newstead, QLD; (07) 52 1339.

7 - 9 Kirk St., Grey Linn, Auckland, NZ; 76 11 69.

Mail Order PO Box 898, Crows Nest, NSW 2065.

Or from:

Applied Technology,  
7a Pattison Ave.,  
Waitara NSW.  
(02) 487 2711.

Radio Despatch Service,  
869 George St., Sydney,  
NSW; (02) 211 0816.

It is expected that kits will also be available through these outlets.

## Heatsinks

Heatsinks on any amplifier are a compromise between cost and temperature rise.

Unless you are going to play long passages of organ music, or run a disco, you will probably find that relatively small heatsinks run quite cool.

However, Darlington transistors are hard to temperature stabilise and should be run as cool as possible. This is why we have opted for a fairly large heatsink compared to other designs. The transistors should be bolted directly to the

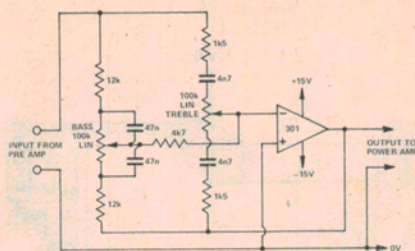
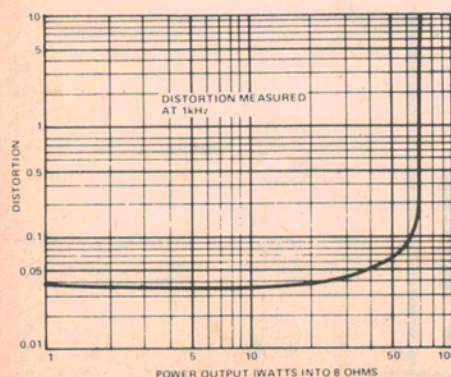

Two suggested tone control circuits for a preamp to suit this module. Low output impedance is an important consideration. Choice of discrete or IC circuitry is given.

heatsink, not through a steel chassis. A slit could be cut in a chassis large enough to slide the assembled amplifier through the rear. Heatsink fins should always be vertical to provide the most efficient convection cooling.

The heatsink recommended for the output devices in this project is a flat-sided type with radial fins, 75 mm in length. Other flat-sided types are available with straight fins, and these too would be suitable. A similar length should be used. In general the heatsink should have a thermal resistance, mounting surface to ambient, of around 1°C per watt.

A small 'flag' heatsink is attached to Q7, a BD140 flatpack transistor. A commercial heatsink may be employed (they're only about 60 cents) or a small strip of aluminium may be bent up, drilled, and bolted to the transistor. See that the metal area of the BD140 and a face of this heatsink are in contact. Heatsink compound should be used.

## Setting Up

Once the amplifier has been assembled and carefully checked, the bias current for the output devices must be set. Remove the fuses, F1 and F2 and connect a 100 ohm resistor across each fuse holder. Remove any input signal. Connect the power supplies and measure the voltage drop across each of these resistors. Adjust the trim pot RV1 for a reading of 2.5 volts across each resistor. This corresponds to a bias current of 25 mA. The reading should be nearly the same across each resistor. Next check that there is no DC voltage across the output terminals.

If the reading across each of the resistors cannot be adjusted, or if there is a DC voltage across the output greater than one volt then there is a fault and the fuses should not be inserted.

If all is well, remove the two resistors and insert the fuses. Connect the speaker and away you go.

## Preamp Considerations

The input impedance of this amplifier is relatively low, falling at very high freq-

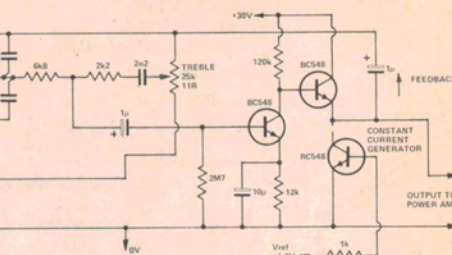

uencies. Consequently, it must be fed from a low impedance source.

When driving the amplifier with a preamp-tone control unit, the output is best taken from an emitter follower circuit (to provide the required low source impedance) or directly from the output of an operational amplifier. In either case, it *must* be taken from the point where the output is fed back to the tone control circuitry.

Two suggested tone control circuits suitable for the application are illustrated in Figure 5. Both use a 'Baxandall' type tone control network with feedback derived from the output point.

The circuit at right uses discrete components which may suit some constructors better. The left circuit, using a commonly available op-amp, has higher distortion than the discrete circuit.

A preamp-control unit project to suit the amplifier module will be described in a forthcoming issue along with details of how to construct a complete stereo amplifier system of high quality.

## PULSE TESTING

Operation into severely reactive loads was examined by looking at the ac component of the  $V_{be}$  of Q10 as a measure of the 'overshoot' of the loop and to see if transient overload occurred.

$f = 1$  kHz. CRO is 0.2 mS/div. Output is 30 V into 8 ohms.

Upper trace 10 V/div. Output into 8 ohms.

Lower trace 10 mV/div.  $V_{be}$  of BD139 gain stage. No evidence of transient overload was visible.

