

# Which P. A. Speaker Should You Use?

By ABRAHAM B. COHEN, ISC/Telephonics  
Division of Instrument Systems Corp.



*Part 3 of a series on modern p.a. sound-system practices describes speakers that are available, gives comparative characteristics, and includes much practical information on making best choice.*

Fig. 1. An example of a direct-radiator cone enclosure with a sectoral high-frequency horn at the top for use in gyms or in small auditoriums. (Altec Lansing 1202A)

**T**HE choice of loudspeakers for p.a. sound systems is determined by four factors: (1) the specific area to be covered by each speaker, (2) the acoustic properties of the area to be covered, (3) the propagation characteristics of the speaker, and (4) its efficiency.

A paging system intended to cover many different rooms of a manufacturing plant will obviously need as many speakers as there are rooms to be covered, with at least one speaker to a room, or more as the size of the room requires. On the other hand, an open-air concert shell or high-quality concert hall or theater may require only one master system placed over the center of the stage.

In a stockroom, where the area is broken up into aisles, storage shelves, bins, storage nooks and crannies and the like, the chances are that the area is generally free from disturbing reverberation. Hence, no special performance is required of the speaker other than it radiate enough sound so that people in the stockroom area can hear it comfortably. In a plant where there is a very noisy and large manufacturing area with cinderblock walls and high glass turreted roof, a network of small speakers placed near where the people paged are most likely to be found, such as at machines or foremen's stations, would be required. Here, the pattern from the individual loudspeakers should concentrate the radiated sound more directly toward the area to be covered, since sound dispersion into the high-ceilinged area might set up disturbing reverberation which could reduce the intelligibility of the message.

If the speaker is intended to reproduce a wide range of music, then the system would generally have to have the characteristics of a "hi-fi" system. If it were to be used for paging purposes, only a relatively narrow band of frequencies must be reproduced to get the message across.

Finally, the speaker selected will determine the amount of audio power necessary to drive the system; direct-radiator speakers having about one-fifth the electro-acoustic efficiency of horn-type reproducers.

## Cone Speakers

The cone-type loudspeaker is generally used as a direct radiator. As direct radiators, they "sound out" directly into the area to be covered. As shown in Fig. 2, they may be mounted in simple small enclosures just large enough to accommodate the loudspeaker being used (usually no larger than an 8" unit), with just enough inner volume to give some semblance of bass reproduction. These are used mainly for low-level paging systems where frequencies below 250 Hz are unnecessary for speech-production and for background music where musical "sedation" rather than fidelity is the goal.

Often these cone speakers will be housed in baffles which are flush-mounted in the ceilings or walls. When mounted in walls, the back of the enclosure is often left open to allow the speaker to produce lower frequencies because the diaphragm is acoustically unclamped, making the enclosure appear larger. However, when mounted in the ceiling, the speaker is usually closed in by a rear box to prevent bits of plaster from falling into the back of the cone. In these small rear-enclosed ceiling mounts, the low frequencies are considerably attenuated. The enclosures need quite a bit of sound damping applied to their inner walls to minimize disturbing resonances within the enclosures.

Bi-directional baffles are often mounted in corridors or on walls, with sound coming out of the back as well as the front. This reduces the number of speakers required, however quality is sacrificed over and above the limited quality of the small enclosure itself. Since it is virtually open on both sides and is housed in a small enclosure, the cone is, for all practical purposes, unbaffled. This results in severe drop out of low frequencies. In addition, the high frequencies from the rear of the speaker are considerably attenuated with respect to the highs coming out of the front of the speaker. Yet despite these characteristics, bi-directional enclosures provide usable paging service and low-level background music in low-noise areas.



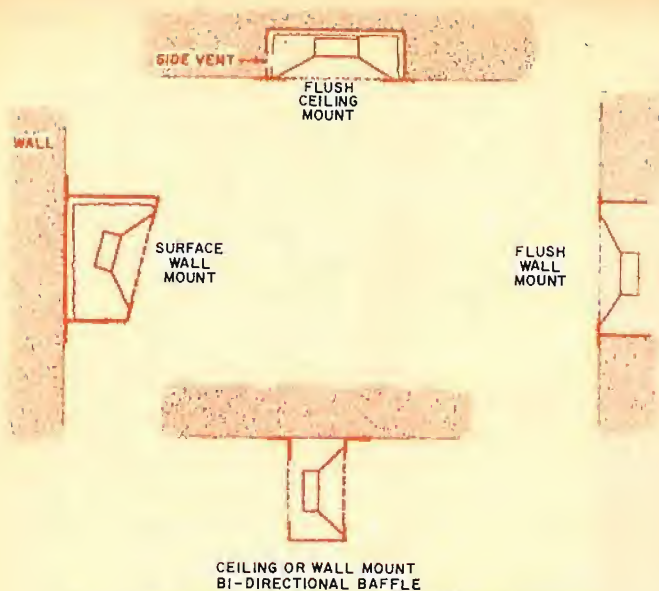

Fig. 2. Cone speakers for paging and utility purposes are housed in small compact metal or wood baffle enclosures.

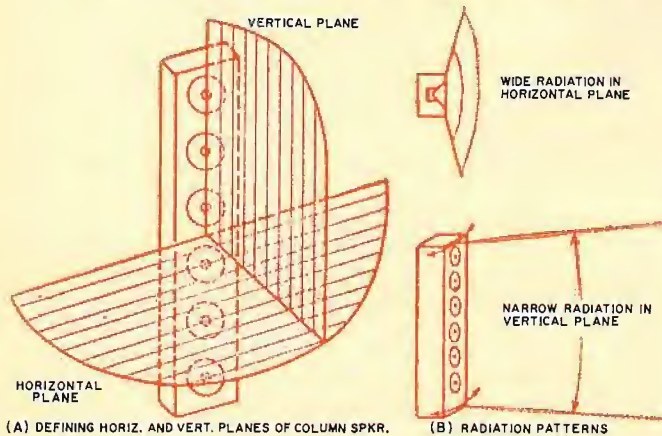

Fig. 3. The column speaker produces a wide-angle wedge of sound energy in horizontal plane at right angles to the column length. Sound wedge is narrow in vertical plane.

For a wider frequency range than that used for paging or background music, and where only moderate sound powers are required, the cone speaker may be mounted in a vented cabinet of the bass-reflex type, or in a sealed enclosure of the acoustic-suspension type. In both cases, the cone acts as a direct radiator, open and facing the audience. With a high-quality woofer, good low-frequency reproduction is possible. However, in almost all instances, a tweeter is a part of the enclosure system to augment the high frequencies of the main cone and to provide better dispersion of the highs.

With the reflex-type enclosure, the tweeter is generally a wide-angle horn to match the efficiency of the cone speak-

er, and may frequently consist of a multicellular or sectoral horn to ensure wide-angle coverage of the higher frequencies (Fig. 1). In the case of the sealed acoustic-suspension system, the enclosure invariably comes as a complete system with the built-in tweeter utilizing either one or two direct-radiator hard-shell dome-type structures to match the woofer efficiency. This tweeter system gives uniform high-frequency distribution rather than directional control of the radiation.

The power requirements of these two systems and the mode of deploying them are very different. Due to the much higher efficiency of the vented enclosure with its tweeter system, satisfactory coverage of an auditorium may be obtained by elevating two such systems on either side of the stage. In the case of the acoustic-suspension type, with its much lower efficiency, perhaps four or five of these enclosures would have to be strung along the footlight area to cover the auditorium. Also, more driving power will be required than for the vented type.

### Column Speakers

The column speaker bridges the gap between the simple cone-radiator structure and the horn system. It will provide sharp directional control patterns but will also retain a good measure of cone-type quality not available from standard horns.

The column, as shown in Fig. 3, is a group of speakers mounted in an array, one above the other, and all facing the same direction. They are usually enclosed in one overall structure which is made as small as possible without deteriorating the bass response below that of which the speaker is capable. Regardless of the physical size of the column, the structure is designed to hold a minimum of four speakers, most frequently six, and not infrequently eight. The major function of the column array is to radiate most of the sound into a rather narrow wedge lying in a plane at right angles to the axis of the column itself, with the arc of coverage of this horizontal wedge often well over 120 degrees. Minimum sound is projected in the vertical direction into the area outside of this comparatively narrow horizontal wedge.

As illustrated in Fig. 4, it is possible to orient the speaker to throw the sound directly into the seating areas to be covered and to minimize the sound beamed at the upper hard-ceiling areas where the sound would otherwise bounce down to the audience with bothersome reverberation. It is surprising how a tilt of just 10 to 15 degrees from the vertical can focus the sound down on the area to be served and permit so little of it to get into the vertical plane.

Sound columns are not very efficient. The column is just a bit more efficient than the cone speaker in the column, but is not as efficient as a horn projector, power for power. However, putting aside the directional control advantage of columns, they have the secondary advantage of being able to handle as much more power than a single cone as there are cones in the array. Where one of the unit cones may be capable of handling 10 watts by itself, it will still take 10 watts in the column configuration, but the whole configura-

Fig. 4. Narrow vertical beam from column speaker system can be used to reduce generation of reverberant sound.

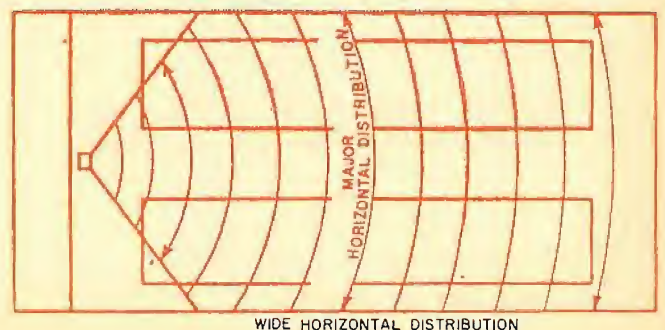
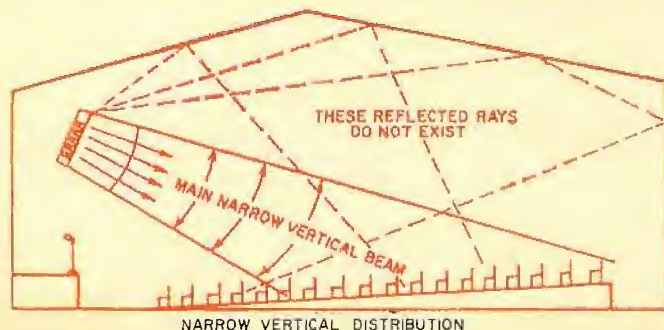



tion made up of perhaps six cones will now be able to take a total of 60 watts.

It is possible to design column speakers for large-area applications where the power-handling capacity may be on the order of 100 watts or more. There is great demand for this type of speaker not only in gymnasiums and large auditoriums, but even for small pop music gathering places where there is apparently no limit to the volume that people can tolerate irrespective of the resultant distortion. The fact that large amounts of power can be fed into the column and a band of frequencies that will cover the electronic instruments used by pop groups can be gotten out of it makes the column a very important system to the sound specialist. Fig. 5 is an example of a two-section break-away column with the top tweeter designed specifically for pop-music use.

In general, the larger the column, the better the low-frequency reproduction and the sharper the horizontal wedge of the sound distribution. Another rule-of-thumb in judging the sharpness of the horizontal pattern is the number of speakers in the column and the means of contouring the high-frequency response. The more speakers in the column, assuming them to be closely spaced, the flatter will be the horizontal wedge; eight radiators will produce a flatter horizontal wedge of sound than will a four-speaker column. When designing column speakers, an attempt is made to keep a constant ratio of radiated wavelength to the physical length of the column. Theory shows that if this condition can be maintained, then the wedge divergence will be uniform at all frequencies. It is obviously impossible to physically shorten the column as high frequencies (shorter wavelengths) are transmitted. The only feasible alternative is to make the column appear to be electro-acoustically shorter for the higher frequencies as they occur.

This automatic contouring is accomplished by one of the following three methods, or combinations of them, as in Fig. 6. (Left) The high-frequency capabilities of the two end speakers are reduced by either choosing their cone design so that they are not as inherently good high-frequency reproducers as the central radiators, or by removing any high-frequency elements, such as whizzers or tweeters from these end speakers. (Right) Electrical filters, such as crossover networks, may be used to prevent the high frequencies from getting into the end speakers. (Center) A separate line of tweeters located at the center of the column will make the tweeter column length to wavelength ratio at the high frequencies similar to that at middle and low frequencies. In some instances, the column itself is slightly arced to keep



Fig. 5. Break-away high-power handling sound column for portable pop-music use. Multi-horn tweeter on top of the column spreads high frequencies (Jensen Models LPC-152, HLV-40)

the highs from being dispersed vertically.

### Horn Projectors

The horn-projector family will continue to be one of the sturdy building blocks of public-address sound systems. The reasons are not hard to understand. The ease of directing sound where it is desired by merely pointing the horn in that direction is readily apparent. The ability of the horn to produce sound that penetrates into very noisy areas is universally recognized. The economy of amplifier power it permits because of its high-efficiency characteristics is a matter of record. That they have time-proven reliability under the most adverse conditions of temperature, humidity, and precipitation is borne out by their use out-of-doors almost to the exclusion of other types.

Most high-efficiency horns used by the p.a. technician are of the re-entrant type. They can be recognized by a central member, resembling a long nose structure, as in Fig. 7. This member is one of three separate sections of the horn, folded around the other, for which the word "re-entrant" was coined.

Such horns, because of their design-controlled geometric expansion, have well-defined specifications, of which the

most important is the low-frequency cut-off point below which the horn theoretically will not transmit any acoustic energy. In this context, every horn is thus a simple high-pass filter. Looking at a group of horns, the larger the mouth of the horn and the longer the air column of the unfolded horn, the lower frequencies it will reproduce. One would expect that the larger horns would have a better sound-level output due to their improved acoustic loading on the driver unit energizing them and their better mouth-to-air impedance match. The table in Fig. 7 gives a general idea of the improvement in sound pressures that may be expected from typical horn sizes. A second rule-of-thumb is that the smaller the mouth of the horn, the wider its angle of sound dispersion. This characteristic stems from basic radiation theory that states that the smaller the radiator, the more it approaches a point source of energy and becomes a spherical radiator. As the radiator becomes larger, it deviates from the character of a point source and begins to develop directional characteristics. Hence, while a large horn mouth may produce better low frequencies and more sound power output, its upper frequency radiation becomes quite sharply beamed with the resultant loss of intelligible wide-angle sound projection.

A horn is a passive device; it does not produce power. The sound it transmits is the sound it receives from some other source of power, in this instance, the compression

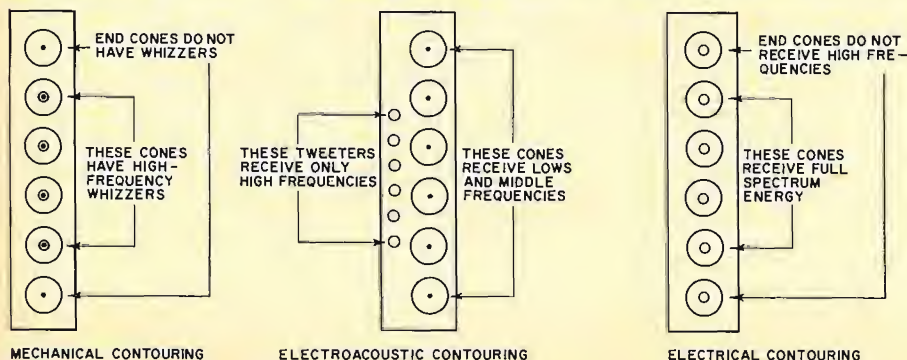
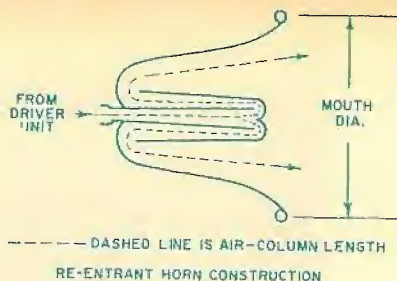

Fig. 6. Three ways of contouring or equalizing column in order to get same directivity pattern at high frequencies.





AIR-COLUMN LENGTH	MOUTH DIA.	CUT-OFF FREQUENCY	ANGULAR DISPERSION	RELATIVE ACOUSTIC GAIN
2 1/2" NOM.	16" NOM.	250Hz	95° NOM.	REFERENCE
3 1/2"	21"	175Hz	85°	+1dB
4 1/2"	26"	120Hz	75°	+2dB
6 1/2"	32"	85Hz	65°	+4dB

OUTPUT

CUT-OFF FREQ.

LOW Hz HIGH

Fig. 7. Construction and performance of re-entrant horns.

driver shown in Fig. 8A. The back of the unit is completely closed off from the outside air. The rear of the vibrating sound-producing diaphragm in the structure is thus under compression of the air trapped behind it. The front of the diaphragm, mounted in the acoustic head, delivers its acoustic energy into the narrow throat end of the horn which is coupled to the driver unit.

The driver unit has a powerful magnetic system which provides the initial source of power to cause a comparatively small diaphragm (usually about 2" in diameter) to be energetically vibrated as a result of the signal current to the voice coil immersed in the magnetic gap and attached to the diaphragm. This powerful magnetic drive (magnetomotive force) acting on the low mechanical impedance of the lightweight diaphragm, produces a very large amount of sound output.

The acoustic energy feeds into the throat of the horn and is allowed to expand at a controlled rate by the design flare of the horn until the sound power emerges from the horn mouth as in Fig. 8B. The horn is basically an acoustic transformer, as well as a high-pass filter. Its controlled expansion permits the high-intensity sound, originating at its throat, to gradually follow the horn expansion and to emerge from a large horn mouth area into the acoustic space in front of it. The large horn mouth thus provides an improved acoustic match to the air around it and accordingly "grabs hold of" that space in front and transfers its emerging power to it. This is the second high-efficiency step to take place in the process.

The high output of the compression driver, aided by the acoustic-matching properties of the horn, provides a combined efficiency of about 25% as compared to that of the cone system whose efficiency is seldom higher than 5%. Because compression-driven horns are very efficient doesn't necessarily mean that they are to be used only where large amounts of power are required. There are horn projectors rated as low as 5 watts input and there are some systems rated at 1800 watts input. The need determines the power requirement.

### Paging & Talk-Back Horns

While the choice of a driver unit (or units on multiple-drive horns) is made on the basis of sound power required out of the horn, the horn in turn is chosen on the basis of the type of field coverage required and the frequency response needed for the application. The horn family is divided into three general categories: (1) paging and talk-back type; (2) high-power long-throw type; and (3) wide-angle dispersion type, covering both of the previous varieties.

Paging and talk-back horns are relatively small, ranging from 6" to 8" in horn-mouth diameter and about the same corresponding physical lengths (see Fig. 9A). They are easy

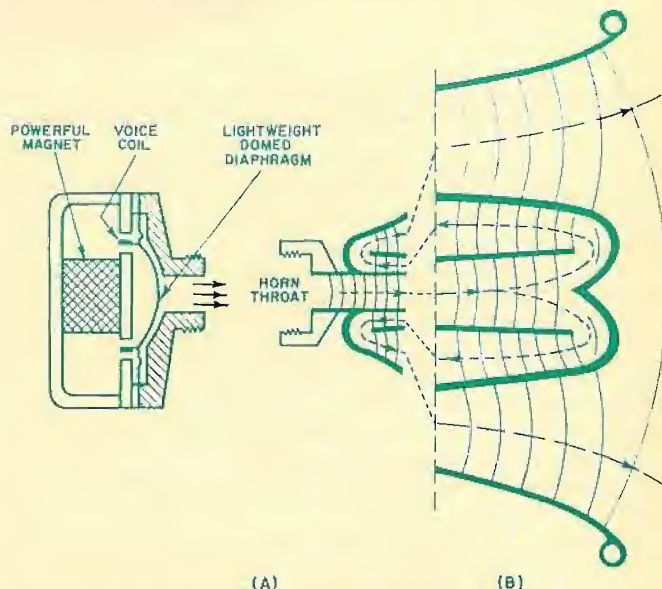

Fig. 8. The high sound output from efficiency compression driver and the good impedance match provided by the horn result in an over-all high efficiency of output.

Fig. 9. Various type of horns for p.a. use. (A, left) Paging and talk-back speaker with integral driver unit, University MIL-A; (B, center) long-throw projector with provision for screw-on driver unit, University GH; (C, right) contoured horn for wide-angle distribution (Atlas CJ-30B).





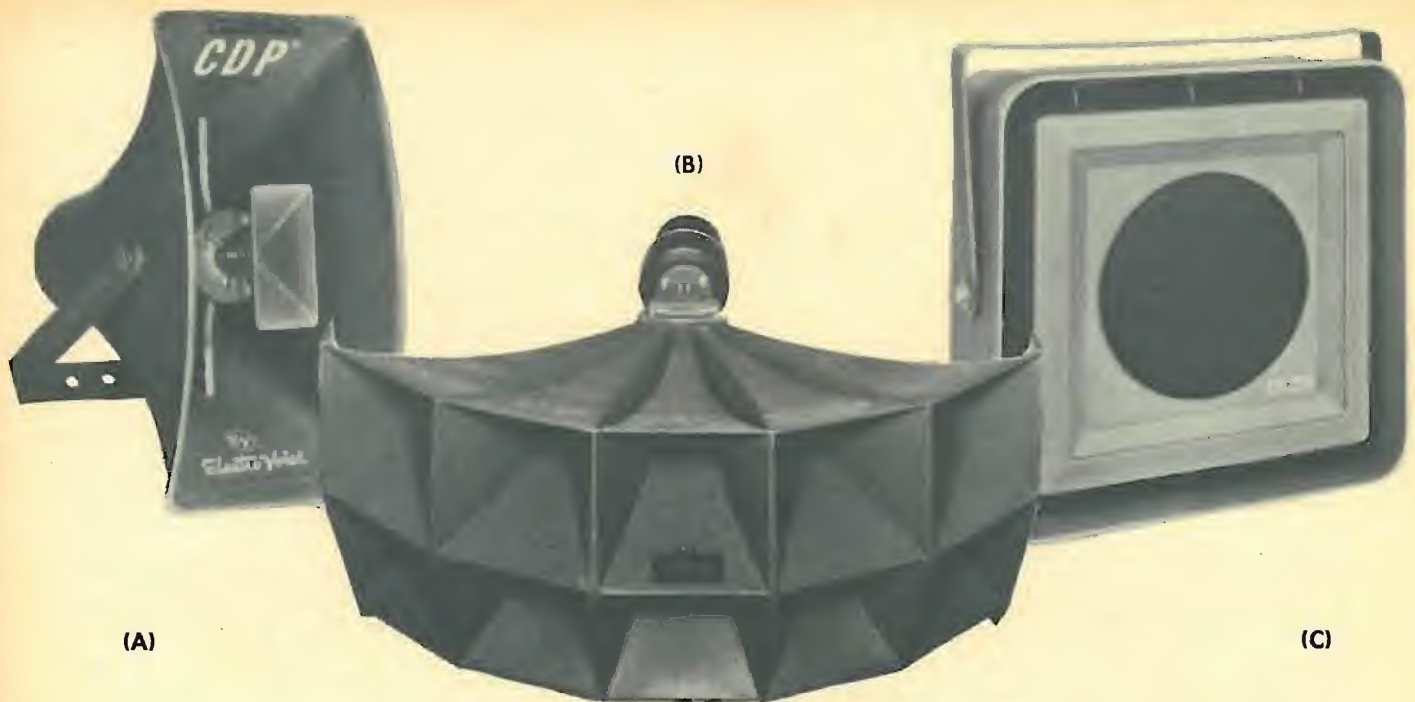

Fig. 10. Additional horns for p.a. use. (A, left) Horn tweeter in mouth of large horn provides wide-angle high-frequency distribution, Electro-Voice 848A; (B, center) 2 x 5 multicellular horn for wide-angle distribution, Altec 1003B; (C, right) rear horn-loaded outdoor speaker, Electro-Voice 1A.

to handle, being generally provided with some sort of a universal swivel mount. They may be conveniently affixed to walls, ceilings, ceiling cross beams, or any convenient abutment near the area to be covered.

Their response characteristics may start anywhere between 250 Hz for the 8" type to 500 Hz for the 6" size, and extend well beyond the upper limit of the speech spectrum. This brackets the band of approximately 250 to 5000 Hz. Articulation with these paging units is exceptionally high. They are placed close to the particular areas where the people to be paged are most likely to be found, and often are located close to or within an area where high noise generating equipment and its operating personnel are stationed.

Successful paging into these areas may be accomplished with moderately small amounts of power per speaker, usually about 5 watts, although such speakers are rated at and will handle as high as 20 watts for extreme conditions. Speakers of this sort may also be found on open-air platforms or in long-corridor systems, such as at airports and in subways where ambient noise may be quite high.

More even sound distribution may be obtained by spotting small speakers at short intervals down the corridor, rather than providing a single high-level source at one end of the corridor. The latter would merely introduce undesirable reverberation and extremely spotty and unevenly distributed sound.

Because the small speakers may be scattered over an area, they serve as high-efficiency microphones when incorporated in a sound system with intercom calling and listening facilities. One may speak quite a distance away from such a speaker and be understood back at the intercom-control station.

The high-power, long-throw horn system (Fig. 9B) is usually represented by the family whose acoustic column lengths may range from  $2\frac{1}{2}$  to  $6\frac{1}{2}$  feet and whose mouth diameters may be from 16 to 32 inches. The standard round horn of this group has a symmetrical distribution pattern of sound energy emerging from its mouth, beamed directly along its axis. Such patterns make it highly suitable for long-throw sound projection as far ahead and in front of the horn as possible, a sort of acoustic "spotlight" type of service. For

such application, it is wise *not* to spread the available energy out over a large area in such a manner that it will have to fight its way, under adverse conditions of air and humidity conditions, only to be lost at the listening area, but rather to beam it ahead for maximum usability.

In long-distance sound throws we cannot hope for real highs as they are absorbed by the air and buffeted about by wind currents. However, considering that we can get usable articulation from the middle frequencies, the symmetrical horn, with its normal beaming, provides excellent acoustic spotlighting of reasonably distant areas. Naturally, a cluster of such horns mounted at a common center can provide high-intensity spots of acoustic energy, one merging with the other to give wide-area coverage.

Focusing of the sound by the round horn may even be a useful adjunct to the horn designed for wide-angle throw (next up for discussion) where the listening audience may be in a park which has heavy outcroppings of "soft" foliage and other brush. The beaming round horn may transmit enough extra acoustic energy into that area to overcome any loss of the original wide-angle distribution at that point.

#### Contoured Horns

Using the same high-efficiency techniques as employed in the standard round horn, other shapes and modifications that produce wide-angle distribution of the sound pattern have been developed. These horns tend to "pancake" the sound pattern into those areas needing the sound energy and minimize the energy into those areas where it would be wasted or cause destructive interference. These problems are precisely the ones that the column speaker was designed to overcome; the horn, however, provides higher efficiency.

One method of obtaining this wide-angle dispersion is by reshaping the horn so that it will throw more sound in one direction than another (Fig. 9C). Another method of improving dispersion is by mounting a high-frequency horn in the center of the mouth of the larger horn (Fig. 10A). The smaller horn, operating as a p.a. tweeter, may be oriented for the direction in which the dispersion is desired. In this case, diffraction effects cause the beam to spread perpendicular to the larger dimension (*Continued on page 59*)



## Which Speaker for P.A.?

(Continued from page 54)

of the mouth of the horns. A third method (Fig. 10B) uses an external multi-mouthed, or multicellular, horn to direct the high frequencies into those areas where the main radiator cannot project. For maximum horizontal dispersion of high frequencies, the horns in Figs. 9C, 10A, and 10B are mounted as shown in the photographs.

Because of the relative lack of low frequencies from horn projectors, they are not by themselves suitable for wide-range "hi-fi" p.a. systems, but are used frequently as the upper frequency elements of a system designed for concert work, especially in applications where distances are to be covered. The multicellular unit may be designated as a  $2 \times 5$  unit or a  $3 \times 6$  unit. This indicates how many rows of small horn are stacked one on top of the other, and how many small horns are in each row. The configuration of such a horn will determine the radiation pattern.

These horn clusters are rated for several cut-off frequencies, so that one has a choice of bandwidth and dispersion characteristics. In some well-designed systems there may be two clusters of horns, a mid-frequency and a high-frequency cluster, both working in conjunction with multiple high-efficiency cone radiators. The multiple low-frequency cones are housed in a bass-reflex enclosure large enough to reproduce very low frequencies cleanly and efficiently. In addition, the cones may be front-loaded with a short horn to raise the efficiency of the lower middle frequencies to be compatible with the efficiencies of the upper frequency clusters. Crossover networks are used and there is a choice of 6, 12, or 18 dB per octave roll-off. Systems such as these are found in theaters for high-quality sound-track reproduction, in large multi-use auditoriums, and for concerts in open shell areas.

We shall next take up the matter of the outdoor installations for patios, outdoor shopping areas and malls, sidewalk restaurants and esplanades, where good fidelity must be obtained from unobtrusive weatherproof speakers. The unit (Fig. 10C) frequently takes the form of either an 8" or 12" cone speaker whose diaphragm is treated with impregnating resins to make the paper stock water-resistant. The structure is that of a forward direct radiator, with the rear of the cone loaded by a short one-bend horn. This rear horn provides some acoustic loading on the back of the speaker so that the cone may radiate low frequencies consistent with the size of the structure. The second purpose of the horn is to protect the cone from rain or wind.

Because the horn is of limited length and since its mouth area is quite small, the low-frequency capability of the horn is limited, although quite adequate for the application. Accordingly the cone-speaker driver is of fairly high resonance, probably between 75 and 100 Hz for a typical patio unit. The front of the cone may be protected by water-imperious cloth, protective screens, and metal grillework which may be decorative as well as protective. One can equate this type of speaker in terms of quality with the column speaker. In this case, however, the patio speaker is almost always omnidirectional, with no important horizontal over vertical advantage. The mouths of such speakers may range in size from approximately 10" across to  $33\frac{1}{2}$ " with the choice, as in all p.a. work, determined by the area to be covered and the quality of performance desired. In the case of the larger models, the systems are usually woofer-tweeter combinations for maximum fidelity.

Any sound system must be approached on the basis of a system philosophy where the system consists not only of an amplifier, distribution system, and loudspeakers but, and most important, the audience to be reached. And to reach it successfully, the industry has designed and provided dozens of specialized loudspeakers for as many varied needs. ▲