

RaneNote 136**Constant-Voltage Audio
Distribution Systems:
25, 70.7 & 100 Volts**

- **Background – Wellspring**
- **U.S. Standards – Who Says?**
- **Basics – Just What *is* “Constant” Anyway?**
- **Voltage Variations – Make Up Your Mind**
- **Calculating Losses – Chasing Your Tail**
- **Wire Size – How Big is Big Enough?**
- **Rane Constant-Voltage Transformers**

**Dennis Bohn
Rane Corporation**

© 1997 Rane Corporation

Background – Wellspring

Constant-voltage is the common name given to a general practice begun in the late 1920s and early 1930s (becoming a U.S. standard in 1949) governing the interface between power amplifiers and loudspeakers used in *distributed sound systems*. Installations employing ceiling-mounted loudspeakers, such as offices, restaurants and schools are examples of distributed sound systems. Other examples include installations requiring long cable runs, such as stadiums, factories and convention centers. The need to do it differently than you would in your living room arose the first time someone needed to route audio to several places over long distances. It became an economic and physical necessity. Copper was too expensive and large cable too cumbersome to do things the home hi-fi way.

Stemming from this need to minimize cost, maximize efficiency, and simplify the design of complex audio systems, thus was born constant-voltage. The key to the solution came from understanding the electric company cross-country power distribution practices. They elegantly solved the same distribution problems by understanding that what they were distributing was *power*, not voltage. Further they knew that power was voltage times current, and that power was conserved. This meant that you could change the *mix* of voltage and current so long as you maintained the same *ratio*: 100 watts was 100 watts – whether you received it by having 10 volts and 10 amps, or 100 volts and 1 amp. The idea bulb was lit. By stepping-up the voltage, you stepped-down the current, and vice-versa. Therefore to distribute 1 megawatt of power from the generator to the user, the power company steps the voltage up to 200,000 volts, runs just 5 amps through relatively small wire, and then steps it back down again at, say, 1000 different customer sites, giving each 1 kilowatt. In this manner large gauge cable is only necessary for the short direct run to each house. Very clever.

Applied to audio, this means using a transformer to step-up the power amplifier’s output voltage (gaining the corresponding decrease in output current), use this higher voltage to drive the (now smaller gauge wire due to smaller current) long lines to the loudspeakers, and then using another transformer to step-down the voltage at each loudspeaker. Nothing to it.

U.S. Standards– Who Says?

This scheme became known as the *constant-voltage distribution method*. Early mention is found in *Radio Engineering, 3rd Ed.* (McGraw-Hill, 1947), and it was standardized by the American Radio Manufacturer’s Association as SE-101-A & SE-106, issued in July 1949¹. Later it was adopted as a standard by the EIA (Electronic Industries Association), and today is covered also by the *National Electric Code (NEC)*².

Basics – Just What is “Constant” Anyway?

The term “constant-voltage” is quite misleading and causes much confusion until understood. In electronics, two terms exist to describe two very different power sources: “constant-current” and “constant-voltage.” Constant-current is a power source that supplies a fixed amount of current regardless of the load; so the output voltage varies, but the current remains constant. Constant-voltage is just the opposite: the voltage stays constant regardless of the load; so the output current varies but not the voltage. Applied to distributed sound systems, the term is used to describe the action of the system *at full power only*. This is the key point in understanding. *At full power the voltage on the system is constant and does not vary as a function of the number of loudspeakers driven*, that is, you may add or remove (subject to the maximum power limits) any number of loudspeakers and the voltage will remain the same, i.e., constant.

The other thing that is “constant” is the amplifier’s output voltage at rated power – and *it is the same voltage for all power ratings*. Several voltages are used, but the most common in the U.S. is 70.7 volts rms. The standard specifies that all power amplifiers put out 70.7 volts at their rated power. So, whether it is a 100 watt, or 500 watt or 10 watt power amplifier, the maximum output voltage of each must be the same (constant) value of 70.7 volts.

Figure 1 diagrams the alternative series-parallel method, where, for example, nine loudspeakers are wired such that the net impedance seen by the amplifier is 8 ohms. The wiring must be selected sufficiently large to drive this low-impedance value. Applying constant-voltage principles results in Figure 2. Here is seen an output transformer connected to the power amplifier which steps-up the full-power output voltage to a value of 70.7 volts (or 100 volts for Europe), then each

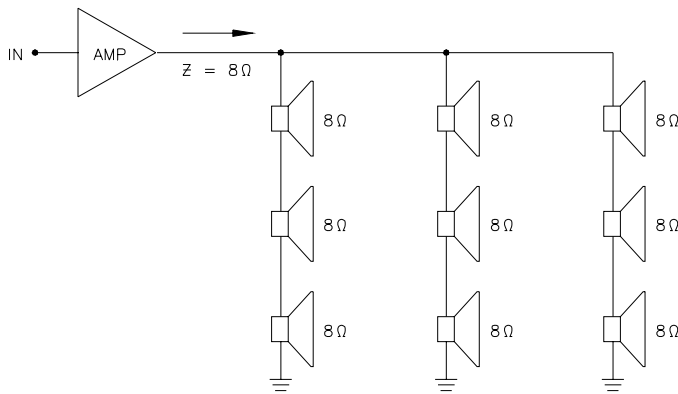

Figure 1. Low-Impedance Series-Parallel 8 ohm Direct Drive Constant-Voltage-2

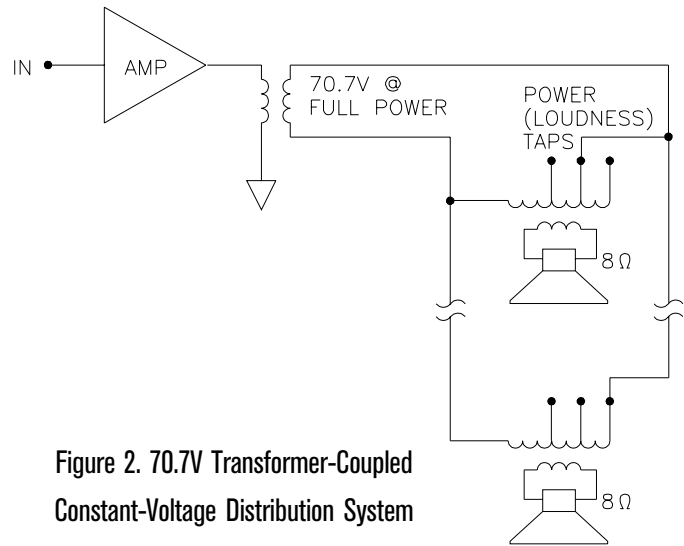

Figure 2. 70.7V Transformer-Coupled Constant-Voltage Distribution System

loudspeaker has integrally mounted step-down transformers, converting the 70.7 volts to the correct low-voltage (high current) level required by the actual 8 ohm speaker coil. It is common, although not universal, to find power (think loudness) taps at each speaker driver. These are used to allow different loudness levels in different coverage zones. With this scheme, the wire size is reduced considerably from that required in Figure 1 for the 70.7 volt connections.

Becoming more popular are various *direct-drive* 70.7 volt options as depicted in Figure 3. The output transformer shown in Figure 2 is either mounted directly onto (or inside of) the power amplifier, or it is mounted externally. In either case, its necessity adds cost, weight and bulk to the installation. An alternative is the direct-drive approach, where the power amplifier is designed from the get-go (I always wanted to use that phrase, and I sincerely apologize to all non-American readers from having done so) to put out 70.7 volts at full power. An amplifier designed in this manner does not have the current capacity to drive 8 ohm low-impedance loads;

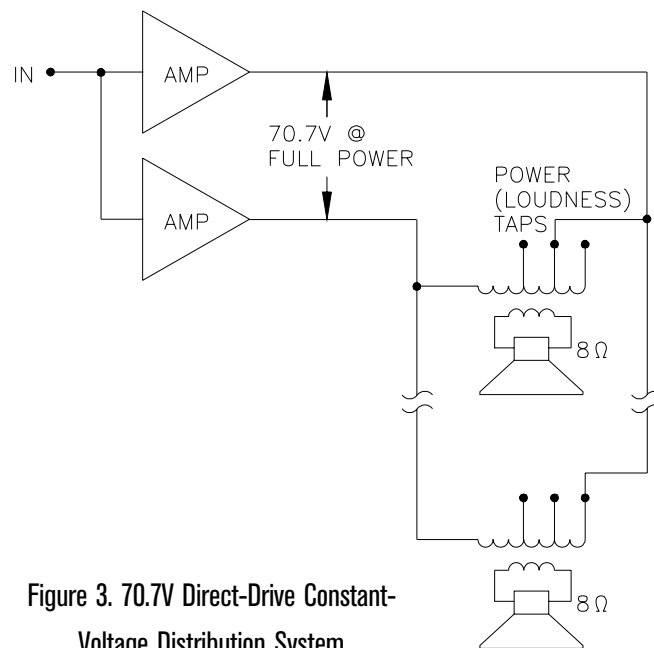

Figure 3. 70.7V Direct-Drive Constant-Voltage Distribution System

instead it has the high voltage output necessary for constant-voltage use – same power; different priorities. Quite often direct-drive designs use bridge techniques which is why two amplifier sections are shown, although single-ended designs exist. The obvious advantage of direct-drive is that the cost, weight and bulk of the output transformer are gone. The one disadvantage is that also gone is the isolation offered by a real transformer. Some installations require this isolation.

Voltage Variations – Make Up Your Mind

The particular number of 70.7 volts originally came about from the second way that constant-voltage distribution reduced costs: Back in the late '40s, UL safety code specified that all voltages above 100 volts peak (“max open-circuit value”) created a “shock hazard,” and subsequently *must be placed in conduit* – expensive – bad. Therefore working backward from a maximum of 100 volts peak (conduit not required), you get a maximum rms value of 70.7 volts ($V_{rms} = 0.707 V_{peak}$). [It is common to see/hear/read “70.7 volts” shortened to just “70 volts” – it’s sloppy; it’s wrong; but it’s common – accept it.] In Europe, and now in the U.S., 100 volts rms is popular. This allows use of even smaller wire. Some large U.S. installations have used as high as 210 volts rms, with wire runs of over one mile! Remember: the higher the voltage, the lower the current, the smaller the cable, the longer the line. [For the very astute reader: The wire-gauge benefits of a reduction in current exceeds the power loss increases due to the higher impedance caused by the smaller wire, due to the current-squared nature of power.] In some parts of the U.S., safety regulations regarding conduit use became stricter, forcing distributed systems to adopt a 25 volt rms standard. This saves conduit, but adds considerable copper cost (lower voltage = higher current = bigger wire), so its use is restricted to small installations.

Calculating Losses – Chasing Your Tail

As previously stated, modern constant-voltage amplifiers either integrate the step-up transformer into the same chassis, or employ a high voltage design to direct-drive the line. Similarly, constant-voltage loudspeakers have the step-down transformers built-in as diagrammed in Figures 2 and 3. The constant-voltage concept specifies that amplifiers and loudspeakers need only be rated in watts. For example, an amplifier is rated for so many watts output at 70.7 volts, and a loudspeaker is rated for so many watts input (producing a certain SPL). Designing a system becomes a relatively simple matter of selecting speakers that will achieve the target SPL (quieter zones use lower wattage speakers, or ones with taps, etc.), and then adding up the total to obtain the required amplifier power.

For example, say you need (10) 25 watt, (5) 50 watt and (15) 10 watt loudspeakers to create the coverage and loudness required. Adding this up says you need 650 watts of amplifier power – simple enough – but alas, life in audioland is never easy. Because of real-world losses, you will need about 1000 watts!

Figure 4 shows the losses associated with each transformer in the system (another vote for direct-drive), plus the very real problem of line-losses. *Insertion loss* is the term

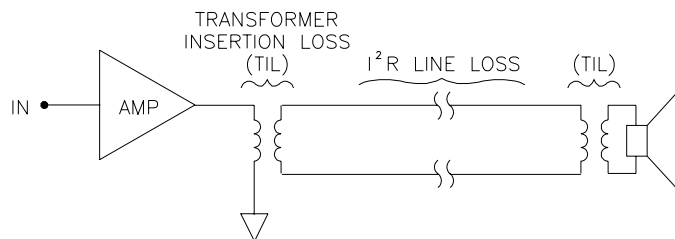

Figure 4. Transformer & Line Insertion Losses

used to describe the power dissipated or lost due to heat and voltage-drops across the internal transformer wiring. This lost power often is referred to as I^2R losses, since power (in watts) is current-squared (abbreviated I^2) times the wire resistance, R . This same mechanism describes line-losses, since long lines add substantial total resistance and can be a significant source of power loss due to I^2R effects. These losses occur physically as heat along the length of the wire.

You can go to a lot of trouble to calculate and/or measure each of these losses to determine exactly how much power is required³, however there is a Catch-22 involved: Direct calculation turns out to be extremely difficult and unreliable due to the lack of published insertion loss information, thus measurement is the only truly reliable source of data. The Catch-22 is that in order to measure it, you must wait until you have built it, but in order to build it, you must have your amplifiers, which you cannot order until you measure it, after you have built it!

The alternative is to apply a very seasoned rule of thumb: *Use 1.5 times the value found by summing all of the loud-speaker powers*. Thus for our example, 1.5 times 650 watts tells us we need 975 watts.

Wire Size – How Big Is Big Enough?

Since the whole point of using constant-voltage distribution techniques is to optimize installation costs, proper wire sizing becomes a major factor. Due to wire resistance (usually expressed as ohms per foot, or meter) there can be a great deal of engineering involved to calculate the correct wire size. The major factors considered are the maximum current flowing through the wire, the distance covered by the wire, and the resistance of the wire. The type of wire also must be selected. Generally, constant-voltage wiring consists of a twisted pair of solid or stranded conductors with or without a jacket.

For those who like to keep it simple, the job is relatively easy. For example, say the installation requires delivering 1000 watts to 100 loudspeakers. Calculating that 1000 watts at 70.7 volts is 14.14 amps, you then select a wire gauge that will carry 14.14 amps (plus some headroom for I^2R wire losses) and wire up all 100 loudspeakers. This works, but it may be unnecessarily expensive and wasteful.

Really meticulous calculators make the job of selecting wire size a lot more interesting. For the above example, looked at another way, the task is not to deliver 1000 watts to 100 loudspeakers, but rather to distribute 10 watts each to 100 loudspeakers. These are different things. Wire size now becomes a function of the geometry involved. For example, if

all 1000 loudspeakers are connected up daisy-chain fashion in a continuous line, then 14.14 amps flows to the first speaker where only 0.1414 amps are used to create the necessary 10 watts; from here 14.00 amps flows on to the next speaker where another 0.1414 amps are used; then 13.86 amps continues on to the next loudspeaker, and so on, until the final 0.1414 amps is delivered to the last speaker. Well, obviously the wire size necessary to connect the last speaker doesn't need to be rated for 14.14 amps! For this example, the fanatical installer would use a different wire size for each speaker, narrowing the gauge as he went. And the problem gets ever more complicated if the speakers are arranged in an array of, say, 10 x 10, for instance.

Luckily tables exist to make our lives easier. Some of the most useful appear in Giddings³ as Tables 14-1 and Table 14-2 on pp. 332-333. These provide cable lengths and gauges for 0.5 dB and 1.5 dB power loss, along with power, ohms, and current info. Great book. Table 1 below reproduces much of Giddings's Table 14-2⁴.

Rane Constant Voltage Transformers

Rane offers several models of constant-voltage transformers. The design of each is a true transformer with separate primary and secondary windings—not a single-winding autotransformer as is sometimes encountered. The transformers are sold individually, and are designed to mount on a separate 3U rack space mounting panel sold separately. For the U.S. market, a tapped secondary is provided offering a choice of 70.7 V or 25 V output voltages. The model **TF 170** is rated 100 watts, while the model **TF 370** is rated for 300 watts. For the European market a 100 watt, 100 V secondary is available as model **TF 110**. The mounting kit for all these models is ordered as a **KTM 6** and mounts (6) 100 W or (3) 300 W or any combination thereof. See the KTM 6 data sheet for more information.

Table 1: 70.7V Loudspeaker Cable Lengths and Gauges for 1.5 dB Power Loss

Wire Gauge >	22	20	18	16	14	12	10	8	
Max Current (A) >	5	7.5	10	13	15	20	30	45	
Max Power (W) >	350	530	700	920	1060	1400	2100	3100	
Load Power	Load Ohms	Maximum Distance in Feet							
1000	5	0	0	0	0	185	295	471	725
500	10	0	93	147	236	370	589	943	1450
400	12.5	0	116	184	295	462	736	1178	1813
250	20	117	186	295	471	739	1178	1885	2900
200	25	146	232	368	589	924	1473	2356	3625
150	33.3	194	309	490	785	1231	1962	3139	4829
100	50	292	464	736	1178	1848	2945	4713	7250
75	66.6	389	618	981	1569	2462	3923	6277	9657
60	83.3	486	774	1227	1963	3079	4907	7851	12079
50	100	584	929	1473	2356	3696	5891	9425	14500
40	125	729	1161	1841	2945	4620	7363	11781	18125
25	200	1167	1857	2945	4713	7392	11781	18850	29000

References

¹ Langford-Smith, F., Ed. *Radiotron Designer's Handbook, 4th Ed.* (RCA, 1953), p. 21.2.

² Earley, Sheehan & Calogero, Eds. *National Electrical Code Handbook, 5th Ed.* (NFPA, 1999).

³ See: Giddings, Phillip *Audio System Design and Installation* (Sams, 1990) for an excellent treatment of constant-voltage system designs criteria; also Davis, D. & C. *Sound System Engineering, 2nd Ed.* (Sams, 1987) provides a through treatment of the potential interface problems.

⁴ Reproduced by permission of the author and Howard W. Sams & Co.