

# MAGNIFICENT

## Resistance Meter

Although practically any multimeter is capable of resistance measurements, apart from digital instruments the number of resistance ranges provided is often rather limited, and the reverse reading non-linear scale is not very convenient in use. This resistance meter, despite being an analogue type, has a forward reading linear scale, and five ranges having full scale values of 1k, 10k, 100k, 1M, and 10M. It can therefore be used to test virtually any resistor that will be encountered in the course of normal electronic project construction and servicing.

The unit uses the same operating principle that is utilized by digital multimeters during resistance measurements. A constant current source is used to provide a certain current to the resistor under test. The voltage developed across a resistor, given a fixed current, is proportional to the value of the resistor. Therefore, if a voltmeter circuit is used to measure the potential developed across the resistor, the meter can in fact be calibrated directly in terms of resistance. For example, consider a test current of 1 milliamp and a voltmeter with a full scale sensitivity of 1 volt. A value of 1 kilohm would give a potential of 1 volt ( $1000 \text{ ohms} \times 0.001 \text{ amps} = 0.1 \text{ volts}$ ) and only 10% of full scale deflection on the meter. In other words the meter reading is proportional to the test resistance, and a forward reading linear scale is obtained.

In the practical circuit IC1 provides the test current, and the LM334 is specifically designed as a current regulator. S1 provides five switched currents of nominally 0.1µA, 1µA, 10µA, 100µA, and 10mA, giving the unit its five measuring ranges. The lowest current is actually outside the recommended operating range of the LM334, but provided this current is trimmed to the right level by means of RV1, accurate results are obtained on this range (the 10M range). The output currents on the other four ranges are controlled by precision (1%) resistors which ensure that good accuracy is obtained on these ranges. The voltmeter circuit must take no significant current from the test resistor if usable results are to be obtained, and IC2 provides the necessary buffering between the test resistor and the meter circuit. IC2 has a MOS input stage which consumes no significant input current. RV2 controls the sensitivity of

by Robert Penfold

the meter circuit and is used to calibrate the unit.

With no test resistor connected across the input the meter would be driven well beyond its full scale value. This problem is overcome by the inclusion of R6, D1, TR1, and R7. With the meter driven within its full scale value the output voltage of IC2 is too low to switch on TR1, and the unit functions normally. However, with an output voltage that is more than marginally above the full scale

potential of the meter circuit TR1 is switched hard into conduction, and it limits the deflection of the meter to a very low level. TR2 and TR3 activate LED indicator D2 when a valid reading is present on ME1.

The unit is calibrated using (say) a 100k 1% resistor, with the unit switched to the 0 to 100k range. RV2 is then adjusted for precisely full scale deflection of the meter. Then the unit is switched to the 10M range, a 10M 1% resistor is connected across SK1 and SK2, and RV1 is adjusted for precisely full scale deflection of ME1.

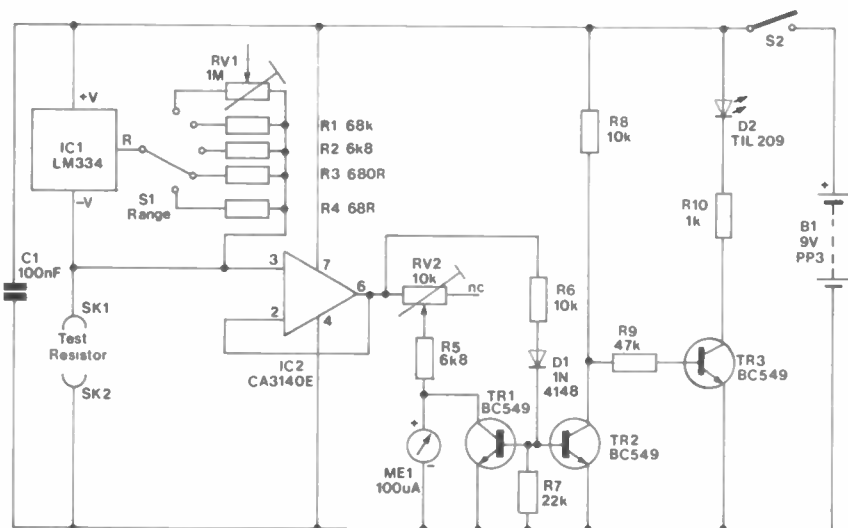

## Woodblock Synthesiser

Woodblock synthesisers are perhaps not the best known type of percussion synthesiser, but they are capable of producing useful effects and are something electronic music enthusiasts should not overlook. This woodblock synthesiser can be triggered either by hitting the pick-up or by means of a +5 volt trigger pulse of a few milliseconds in duration. The pitch is adjustable over a wide frequency range.

A woodblock sound requires a fairly complex waveform since it consists of not just a fundamental signal plus harmonics, but a fundamental signal plus other frequencies close to this fundamental one. A suitable waveform cannot be produced using an oscillator, and the

most simple method of generating a satisfactory signal is to use a noise source plus a very narrow bandwidth bandpass filter.

In this circuit the basic noise signal is generated by the reverse biased base/emitter junction of TR1. This breaks down at about 6 volts in zener diode fashion, and like a zener diode generates noise spikes. The noise output is greater than that from a zener diode though, but the high level of amplification provided by common emitter amplifier TR2 is still needed in order to give a strong output. TR1 can be virtually any npn silicon transistor, and in practice it is probably best to try a few devices from the spares box to find one that gives a really good noise output. C3 provides some initial

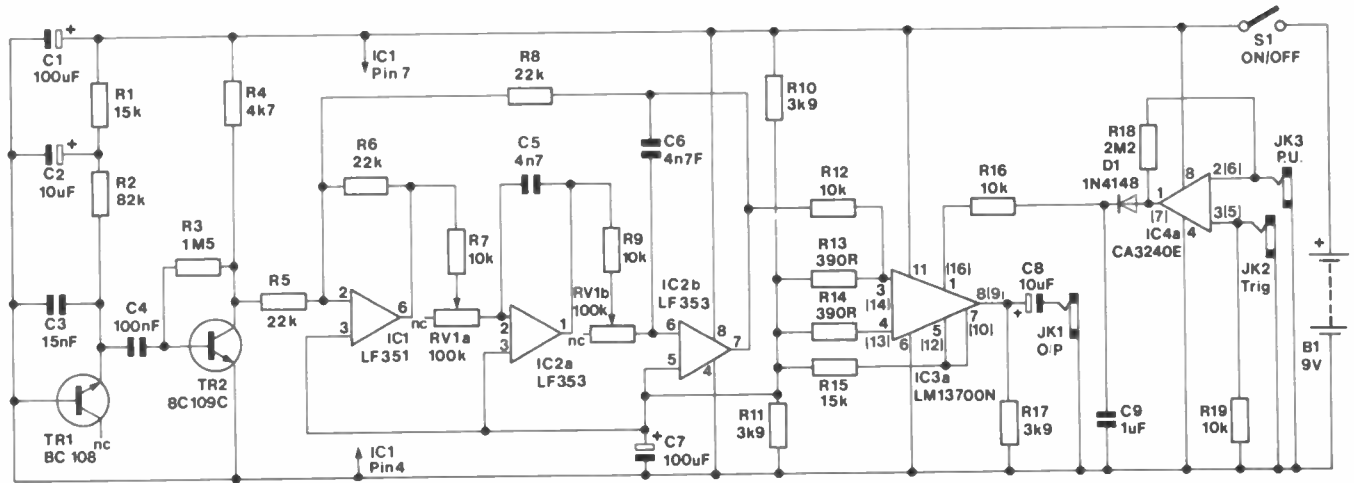

lowpass filtering that prevents the final output from having an excessive high frequency content.

The output from TR2 is fed to what is really a state variable filter (and which is based on IC1 and IC2). However, in this case it is only the lowpass output of the filter that is utilised - the highpass and bandpass outputs just being ignored. The filter is used at a high Q value so that a narrow and pronounced peak is produced in the frequency response just below the cut-off frequency, and the type of filtering obtained is actually a cross between bandpass and lowpass filtering. This gives an excellent output signal for

this application, and the pitch of the output can be varied from about 200Hz to 20kHz by means of RV1.

Envelope shaping is, of course, essential if a usable effect is to be obtained. In this circuit IC3a operates as the voltage controlled amplifier, and this is a straightforward circuit using an operational transconductance amplifier. IC4 and its associated components generate a simple attack - decay control voltage from the input trigger pulse or the pulses from the pick-up. The latter can be a ceramic resonator or a crystal microphone insert.

One section of IC3 is left unused, and

the pin numbers for the unused section are shown in brackets on the circuit diagram. In practice the unit would be most useful if two or more synthesisers are constructed, and the second section of IC3 does not have to be wasted. The noise source can be used for several synthesisers, but the filter, envelope generator, and VCA circuits would need to be duplicated for each synthesiser. If several synthesisers are built and they are to be triggered by pick-ups it is essential to have these reasonably well (physically) isolated from one another to prevent unwanted multiple triggering from occurring.

## RESISTANCE METER PARTS LIST

### RESISTORS - All 0.4W 1% Metal Film

Part	Value	Qty	Code
R1	68k	1	(M68K)
R2,5	6k8	2	(M6K8)
R3	680Ω	1	(M680R)
R4	68Ω	1	(M68R)
R6,8	10k	2	(M10K)
R7	22k	1	(M22K)
R9	47k	1	(M47K)
R10	1k	1	(M1K)
RV1	1M Hor S-Min Preset	1	(WR64U)
RV2	10k Hor S-Min Preset	1	(WR58N)

### CAPACITORS

C1	100nF Ceramic	1	(BX03D)
----	---------------	---	---------

### SEMICONDUCTORS

IC1	LM334	1	(WQ32K)
IC2	CA3140E	1	(QH29G)
TR1,2,3	BC549	3	(QQ15R)
D1	1N4148	1	(QL80B)
D2	Red LED	1	(WL32K)

### MISCELLANEOUS

SK1,2	1mm Socket	2	(WL59P)
S1	Rotary Switch 2-pole 6-way	1	(FF74R)
S2	SPST Ultramin Toggle	1	(FH97F)
ME1	100μA Panel Meter	1	(RW92A)
B1	Battery 9V PP3	1	(FK62S)
	Battery Connector	1	(HF28F)
	DIL Socket 8-pin	1	(BL17T)

## WOODBLOCK SYNTHESISER PARTS LIST

### RESISTORS - All 0.4W 1% Metal Film unless specified

R1,15	15k	2	(M15K)
R2	82k	1	(M82K)
R3	1M5 ½W 5% Carbon	1	(B1M5)
R4	4k7	1	(M4K7)
R5,6,8	22k	3	(M22K)
R7,9,12,16,19	10k	5	(M10K)
R10,11,17	3k9	3	(M3K9)
R13,14	390R	2	(M390R)
R18	2M2 ½W 5% Carbon	1	(B2M2)
RV1	Dual Pot Lin 100k	1	(FW88V)

### CAPACITORS

C1,7	100μF 10V Axial Electrolytic	2	(FB48C)
C2,8	10μF 25V Axial Electrolytic	2	(FB22Y)
C3	15nF Polyester	1	(BX71N)
C4	100nF Polyester	1	(BX76H)
C5,6	4n7F Carbonate	2	(WW26D)
C9	1μF Carbonate	1	(WW63H)

### SEMICONDUCTORS

IC1	LF351	1	(WQ30H)
IC2	LF353	1	(WQ31J)
IC3	LM13700N	1	(YH64U)
IC4	CA3240E	1	(WQ21X)
TR1	BC108C	1	(QB32K)
TR2	BC109C	1	(QB33L)
D1	1N4148	1	(QL80B)

### MISCELLANEOUS

JK1,2,3	6.35mm Jack Socket	3	(HF91Y)
S1	SPST Ultramin Toggle	1	(FH97F)
B1	Battery 9V PP9 Size	1	(FM05F)
	Battery Connector	1	(HF27E)