

Envelope Follower For Guitars and Organs

Very little has been done in India regarding electronic musical instruments while Indian musical instruments field has been totally ignored. For amateur guitarists it is very difficult to obtain electronic gadgets since they are not made locally. Hence, an electronic musical gadget is presented here for those who are unable to buy such units because of their high cost or total non-availability.

This unit produces a similar effect as a 'Wah-Wah' which is familiar to most music enthusiasts, but it is automated. It is actually designed for electric guitars though it is equally adaptable for electronic organs. It is connected between the

variable band-pass filter whose passband is controlled by the envelope of the input audio signal itself. The complete circuit diagram is shown in Fig. 2.

Op-amp A1 is connected as a unity gain buffer amplifier. R1, R2 and C1 are chosen to give the circuit a moderate

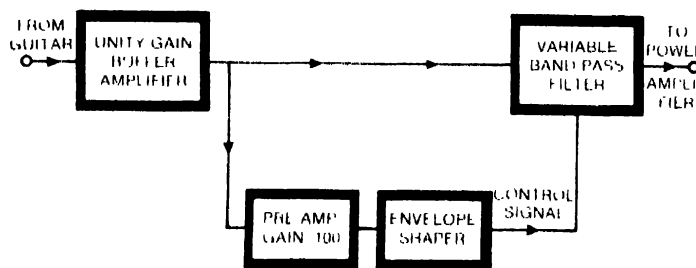

Fig. 1: Block diagram for an envelope follower.

guitar and power amplifier and gives the 'Wah' effect automatically whenever you play the guitar. Professional grade quality can be obtained from this unit.

The circuit

It is clear from the block diagram in Fig. 1 that it is a

Mr Gowdama Chandran is an experienced guitarist as well as an electronic hobbyist, though he's a civil engineering draughtsman by profession.

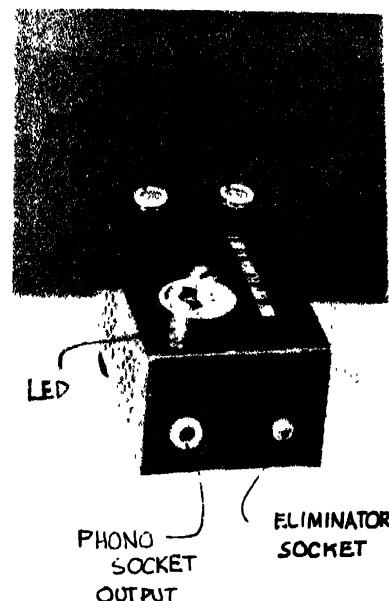

The author's prototype of the envelope follower.

input impedance. The inverted audio signals obtained from A1 are made to pass through a passive high-pass filter formed by C3 and R3.

Op-amp A2 is connected as a preamplifier with a gain of

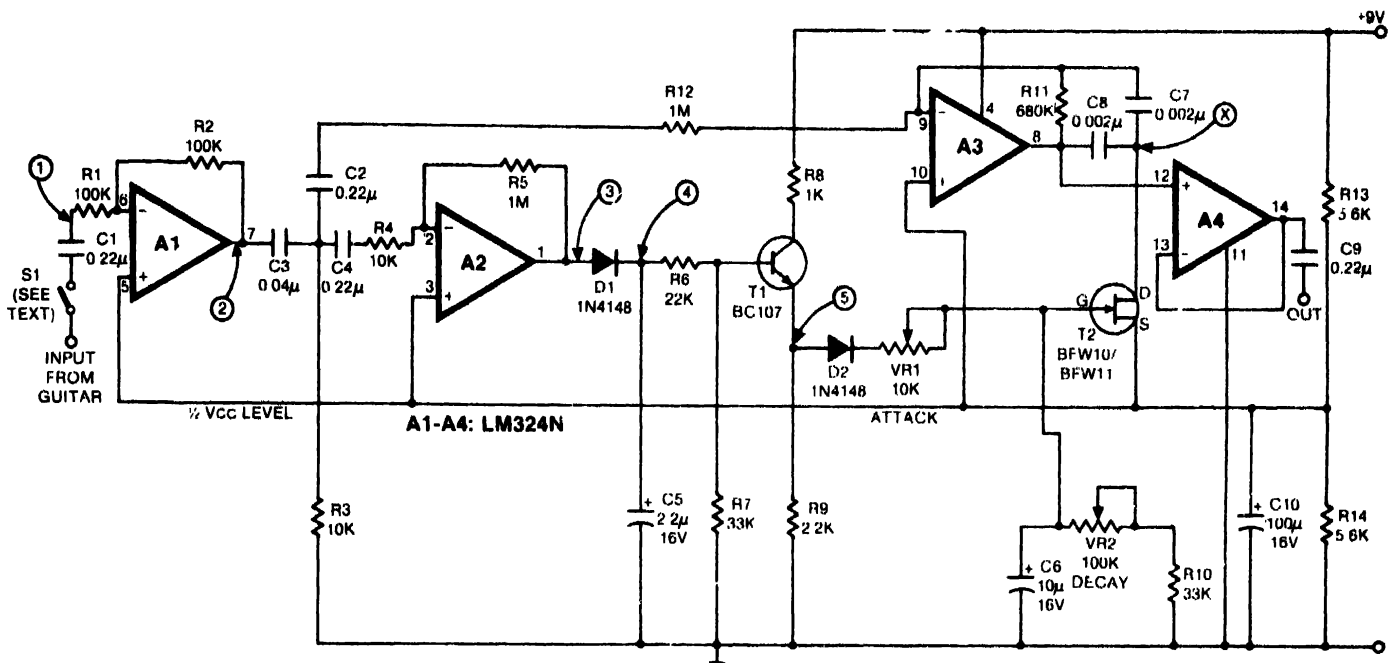

Fig. 2: Circuit diagram for the envelope follower.

PARTS LIST

Semiconductors:

- IC1 — LM324 quad op-amp
- T1 — BC107 npn transistor
- T2 — BFW10/BFW11 field effect transistor
- D1, D2 — 1N4148 silicon switching diode
- D3 — 5mm LED

Resistors [all 1/4 watt, ±5% carbon]:

- R1, R2 — 100-kilohm
- R3, R4 — 10-kilohm
- R5, R12 — 1-megohm
- R6 — 22-kilohm
- R7, R10 — 33-kilohm
- R8 — 1-kilohm
- R9 — 2.2-kilohm
- R11 — 680-kilohm
- R13, R14 — 5.6-kilohm
- R15 — 680-ohm
- VR1 — 10-kilohm, linear potentiometer
- VR2 — 100-kilohm, linear potentiometer

Capacitors:

- C1, C2, C4, C9 — 0.22µF ceramic disc
- C3 — 0.04µF ceramic disc
- C5 — 2.2µF, 16V electrolytic
- C6 — 10µF, 16V electrolytic
- C7, C8 — 0.002µF ceramic disc
- C10 — 100µF, 16V electrolytic

Miscellaneous:

- S1 — Push-to-on DPDT switch
- PCB, battery holder, phono sockets, enclosure, screws, nuts, other hardware etc.

100. The amplification is decided by resistors R5 and R4. Capacitor C4 is included to isolate the input of the preamp from negative potential.

The amplified signal is rectified by diode D1 while capacitor C5 eliminates the AC components. This DC voltage

obtained is known as the envelope of the input signal.

Since the output of op-amp A2 will be at 1/2 VCC at rest, the envelope signal will be swinging above this level only, which is undesirable. Hence transistor T1 is employed to lower this base level. Resistors R6 and R7 give bias for the base of T1 while R8 is used as collector load resistor. Resistor R9 has been chosen to develop the required DC level at emitter of

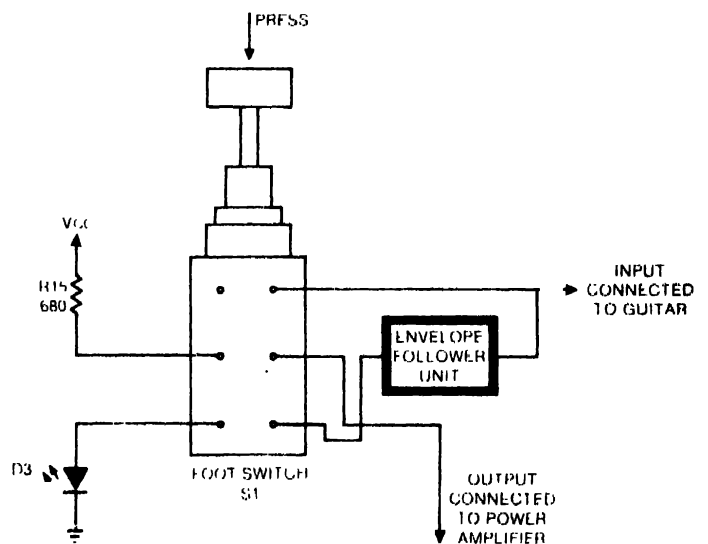

Fig. 3: Wiring diagram for foot-operated DPDT switch.

11. Filter

Op-amp A3 forms the band-pass filter. R11 is the feedback resistor while C7 and C8 are the components that decide the 'Q' factor of the filter.

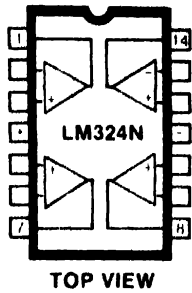

Fig. 4: Pin configuration of IC LM324.

Note that the input resistor R12 is greater in value than the feedback resistor R11 and is not connected to point 'X' in the circuit. On the contrary, it has been connected to the inverting input of A3 and gives a brilliant tone 'colour'.

C2 is the DC blocking capacitor. Resistance offered between points 'X' and $\frac{1}{2} V_{CC}$ decides the passband of the filter. Here field-effect transistor T2 is utilised as a variable resistor connected between these two points.

Although the FET's drain and source terminals are interchangeable, they are connected to higher and lower impedance points respectively. The gate terminal is negatively biased through R10 and VR2.

The envelope voltage from T1's emitter is applied through D2 and VR1 to the gate of the FET. This voltage charges C6

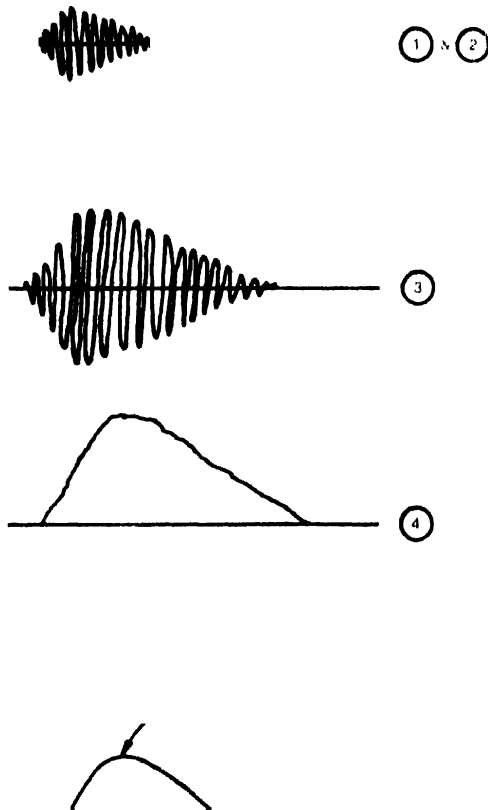

Fig. 5: Typical waveforms observed on a scope at various points in the circuit.

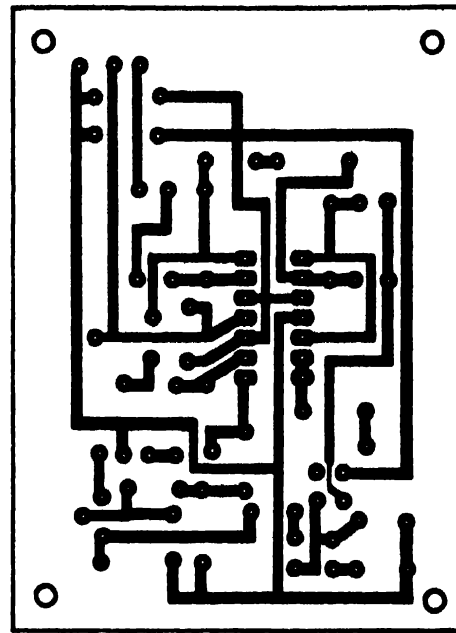
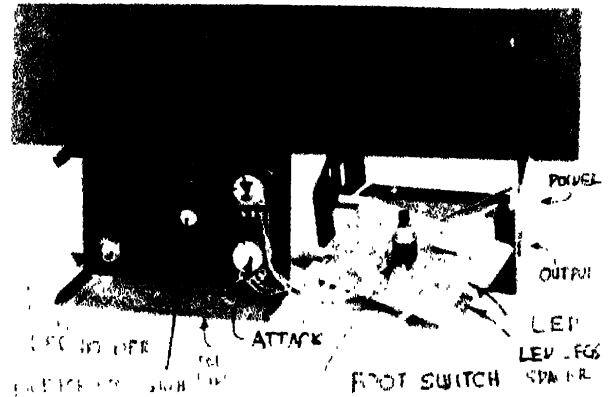

Fig. 6: Actual-size PCB pattern for the circuit.



Inside view of the author's prototype.

which shapes the envelope. D2 prevents C6 from discharging through R9 and hence the discharge is possible through VR2 and R10 only. The 'attack' and 'decay' of the envelope is adjustable by VR1 and VR2 respectively.

At rest, the gate of T2 is negatively biased and hence a very high resistance is offered between the drain and source terminals of the FET. When the envelope is present the resistance varies accordingly. It follows that the passband of the filter is made to sweep across the audio spectrum which gives a 'Wah' effect.

The output of A3 is buffered by the voltage follower built around A4 and DC blocking capacitor C9. Finally, $\frac{1}{2} V_{CC}$ is developed by the potential divider comprising R13 and R14, and is smoothed by C10.

The circuit is powered by a 9V, PP3 battery. It may be powered by a battery eliminator, but a regulated power supply is preferable.

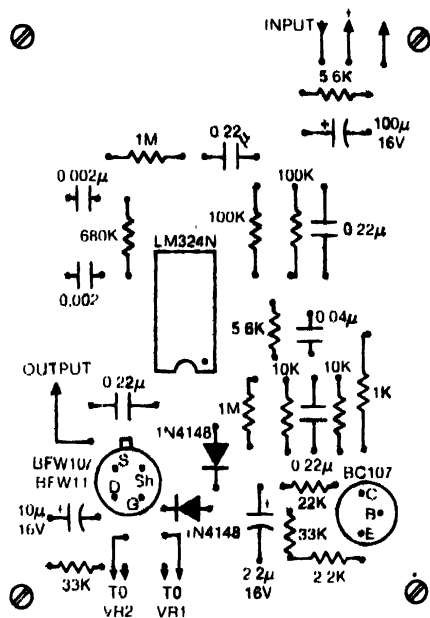

Fig. 7: Components layout for the PCB.

Construction

Any op-amp may be used for A1 to A4. However, quad op-amp LM324N is recommended for its low cost and simplicity of the layout. The pin configuration of this IC is given in Fig. 4.

The printed circuit board shown in Fig. 6 makes the construction simple and easy. The assembled board may be housed in an eliminator box to save the labour for cutting and bending sheet metal for a special enclosure. A foot switch should be provided at the top of the box to permit easy switching 'in' and 'out' of the unit in the guitar-amplifier path.

An LED is provided to indicate whether the unit is switched 'in' or 'out' of the circuit. Note that the LED should be mounted on the top lid of the box. VR1 and VR2 should also be mounted on the top lid, without obstructing visibility of the LED.

Phono sockets can be used for signal 'in' and 'out' terminals. The power supply may be kept outside the box in another case of a battery eliminator.

The assembled unit should give an excellent performance with a guitar. If an organ is connected to it, the components responsible for 'attack' part of the envelope should be modified. A resistor of 10k to 47k value should be inserted between D2 and VR1, depending upon the signal level of the organ used. □

Always Better Reliability
is our company Philosophy.
We ensure absolute Reliability,
on quality, performance and
after sales service.

ABR

Television Chassis (B&W) 36cm and 51cm.



We design develop and manufacture B&W Television chassis and other electronic consumer products

We can supply tested Television chassis for B&W Television sets in SKD form to intending manufacturers of Televisions

We also provide full training in production to their technicians and engineers.

For further particulars write to

Electronics Private Limited

Plot No HIG 'A'-48 Dr. A.S. Rao Nagar Hyderabad-500 762
Phone: 850232

SHIVLINE RECHARGEABLE LIGHTS & INVERTER-CHARGER MODULES



BEAM LIGHT



LANTERN



CAB LIGHT

Inverter-Chargers : 6VDC—4, 6, 10 & 20 Watts
12VDC—4, 6, 10, 20 & 40 Watts
24VDC—20W

Applications : Emergency Lighting Equipment using M/C, Ni-Cd or Gel batteries.

Manufactured by:

Shiv Shakti Electronics (P) Ltd

F-274, Flatted Factories Complex, Okhla Industrial Estate
New Delhi-110020 (Ph: 632023)