

BuildYourGuitar.com

[Home](#) > [Resources](#) >

The Secrets of Electric Guitar Pickups

By *Helmuth E. W. Lemme*

Update: July 22, 2003

An electric bass or guitar's sound depends greatly on its pickups. There are lengthy discussions between musicians about the advantages and disadvantages of different models, and for someone who has no knowledge of electronics the subject may seem to be very complicated. Electrically, though, pickups are fairly easy to understand - so this article will examine the connection between electrical characteristics and sound.

I am sorry to say that most pickup manufacturers spread misleading information on their products, in order to make more money and to agitate their competitors. So some corrections of facts will be necessary. I am not affiliated with any manufacturer.

There are two basic pickup types, magnetic pickups and piezoelectric pickups. The latter type work with all kinds of strings (steel, nylon, or gut). Magnetic pickups work only with steel strings, and consist of magnets and coils. Singlecoil pickups are sensitive to magnetic fields generated by transformers, fluorescent lamps, and other sources of interference, and are prone to pick up hum and noise from these sources. Dual coil or "humbucking" pickups use two specially configured coils to minimize this interference. Because these coils are electrically out of phase, common-mode signals (i.e. signals such as hum that radiate into both coils with equal amplitude) cancel each other.

The arrangement of the magnets is different for different pickups. Some types have rod or bar magnets inserted directly in the coils, while others have magnets below the coils, and cores of soft iron in the coils. In many cases these cores are screws, so level differences between strings can be evened out by screwing the core further in or out. Some pickups have a metal cover for shielding and protection of the coils, others have a plastic cover that does not shield against electromagnetic interference, and still others have only isolating tape for protecting the wire.

The magnetic field lines flow through the coil(s) and a short section of the strings. With the strings at rest, the magnetic flux through the coil(s) is constant. Pluck a string and the flux changes, which will induce an electric voltage in the coil. A vibrating string induces an alternating voltage at the frequency of vibration, where the voltage is proportional to the velocity of the strings motion (not its amplitude). Furthermore, the voltage depends on the string's thickness and magnetic permeability, the magnetic field, and the distance between the magnetic pole and the string.

There are so many pickups on the market that it is difficult to get a comprehensive overview. In addition to the pickups that come with an instrument, replacement pickups - many of them built by companies that do not build guitars - are also available. Every pickup produces its own sound; one may have a piercing metallic quality, and another a warm and mellow sound. To be precise: A pickup does not "have" a sound, it only has a "transfer characteristic". It transfers the sound material that it gets from the strings and alters it, every model in its own fashion. For instance: Mount the same Gibson humbucker on a Les Paul and on a Super 400 CES: you will hear completely different sounds. And the best pickup is useless when you have a poor guitar body with poor strings. The basic rule is always: garbage in - garbage out!

Replacement pickups allow the guitarist to change sounds without buying another instrument (within the limitations of body and strings, of course). Different pickups also have different output voltages. High output models can make it easier to overdrive amplifiers to produce a dirty sound, while low output models tend to

produce a more clean sound. The output voltage of most pickups varies between 100 mV and 1 V RMS.

Unlike other transducers that have moving parts (microphones, speakers, record player pickups etc.), magnetic guitar pickups have no moving parts - the magnetic field lines change, but they have no mass. So evaluating pickups is much easier than with other transducers. Although the frequency responses of nearly all available magnetic pickups are nonlinear (which creates the differences in sound), they don't have quite as many adjacent peaks and notches in their frequency response as for example a speaker. In fact, the frequency response can be smooth and simple enough to be easily described with a mathematical formula.

The Pickup as Circuit

From an electrical standpoint, a magnetic guitar pickup is equivalent to the circuit in Fig. 1.

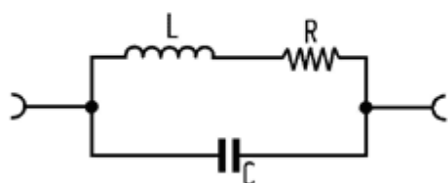

Fig. 1. Electrical equivalent circuit of a magnetic pickup

A real coil can be described electrically as an ideal inductance L in series with an Ohmic resistance R , and parallel to both a winding capacity C . By far the most important quantity is the inductance, it depends on the number of windings, the magnetic material in the coil, and the geometry of the coil. The resistance and the capacitance don't have much influence and can be neglected. When the strings are moving, an AC voltage is induced in the coil. So the pickup acts like an AC source with some attached electric components (Fig. 2).

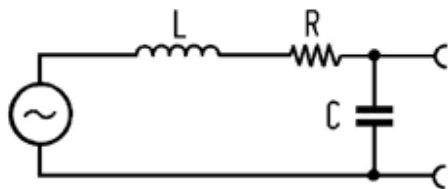

Fig. 2. A pickup as an audio voltage source plus second-order lowpass

The external load consists of resistance (the volume and tone potentiometer in the guitar, and any resistance to ground at the amplifier input) and capacitance (due to the capacitance between the hot lead and shield in the guitar cable). The cable capacitance is significant and must not be neglected. This arrangement of passive components forms a so-called second-order low-pass filter (Fig. 3).

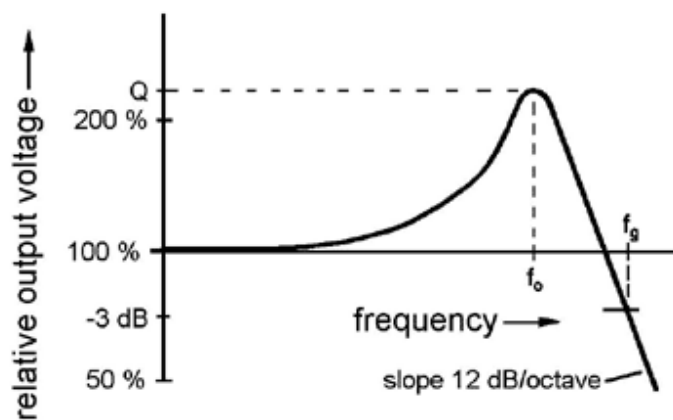
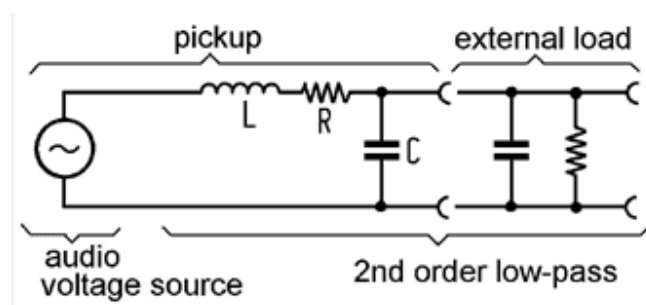

Fig. 3. A pickup plus real external load (pots, cable, and amp input resistance)

Thus, like any other similar filter, it has a cut-off frequency f_g ; this is where the response is down 3 dB (which means half power). Above f_g , the response rolls off at a 12 dB per octave rate, and far below f_g , the attenuation is zero. There is no low frequency rolloff; however, a little bit below f_g there is an electrical resonance between the inductance of the pickup coil and the capacitance of the guitar cable. This frequency, called f_{max} , exhibits an amplitude peak. The passive low-pass filter works as a voltage amplifier here (but doesn't amplify power because the output current becomes correspondingly low, as with a transformer). Fig. 4 shows the typical contour of a pickup's frequency response.



**Fig. 4. Fundamental frequency response of a magnetic pickup.
Position and height of the peak vary from type to type**

If you know the resonant frequency and height of the resonant peak, you know about 90 percent of a pickup's transfer characteristics; these two parameters are the key to the "secret" of a pickup's sound (some other effects cannot be described using this model, but their influence is less important).

What all this means is that overtones in the range around the resonant frequency are amplified, overtones above the resonant frequency are progressively reduced, and the fundamental vibration and the overtones far below the resonant frequency are reproduced without alteration.

How Resonance Affects Sound

The resonant frequency of most available pickups in combination with normal guitar cables lies between 2,000 and 5,000 Hz. This is the range where the human ear has its highest sensitivity. A quick subjective correlation of frequency to sound is that at 2,000 Hz the sound is warm and mellow, at 3,000 Hz brilliant or present, at

4,000 Hz piercing, and at 5,000 Hz or more brittle and thin. The sound also depends on the height of the peak, of course. A high peak produces a powerful, characteristic sound; a low peak produces a weaker sound, especially with solid body guitars that have no acoustic body resonance. The height of the peak of most available pickups ranges between 1 and 4 (0 to 12 dB), it is dependent on the magnetic material in the coil, on the external resistive load, and on the metal case (without casing it is higher; many guitarists prefer this).

The resonant frequency depends on both the inductance L (with most available pickups, between 1 and 10 Henries) and the capacitance C . C is the sum of the winding capacitance of the coil (usually about 80 - 200 pF) and the cable capacitance (about 300 - 1,000 pF). Since different guitar cables have different amounts of capacitance, it is clear that using different guitar cables with an unbuffered pickup will change the resonant frequency and hence the overall sound.

Altering Pickup Characteristics

Basically, there are three different ways to change a guitar's sound as it relates to pickups:

1. Install new pickups. This method is most common, but also the most expensive.
2. Change the coil configuration of the built in pickups. This is possible with nearly all humbucking pickups. Normally, both coils are switched in series. Switching them in parallel cuts the inductance to a quarter of the initial value, so the resonant frequency (all other factors being equal) will be twice as high. Using only one of the coils halves the inductance, so the resonant frequency will increase by the factor of the square root of 2 (approximately 1.4). In both cases, the sound will have more treble than before. Many humbucking pickups have four output wires - two for each coil - so different coil combinations can be tried without having to open the pickup. Some single coil pickups have a coil tap to provide a similar flexibility.
3. Change the external load. This method is inexpensive but can be very effective. With only a little expense for electronic components, the sound can be shaped within wide limits. Standard tone controls lower the resonant frequency by connecting a capacitor in parallel with the pickup (usually through a variable resistor to give some control over how much the capacitor affects the pickup). Therefore, one way to change the sound is to replace the standard tone control potentiometer with a rotary switch that connects different capacitors across the pickup (a recommended range is 470 pF to 10 nF). This will give you much more sound variation than a standard tone control (Fig. 5).

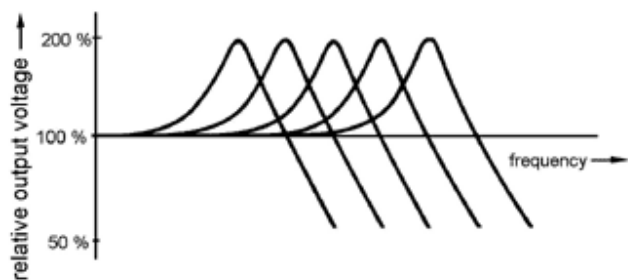

Fig. 5. Changing the frequency response with different external capacitors parallel to a pickup coil

These rotary switches are commercially available now, handmade by the author, embedded in epoxy resin (Fig. 6).

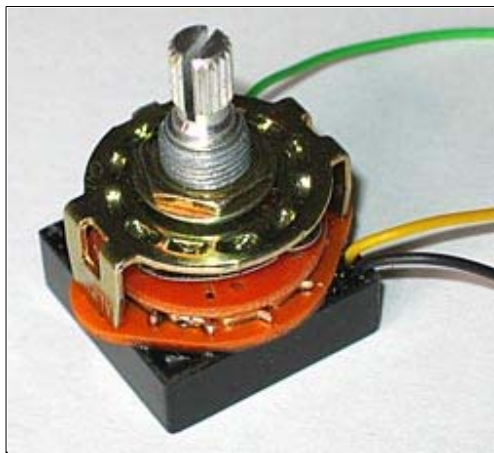

Fig. 6. Rotary switch with a selection of different capacitors, embedded in epoxy resin

Also, adding an internal buffer amplifier can isolate the pickup from some of the loading effects of cable capacitance, thus giving a brighter sound with higher resonance frequency and higher peak.

The Table correlates some well-known pickups and their electrical characteristics. However, note that pickups are not precision devices and that old pickups in particular (eg. Fender and Gibson pickups of the fifties) vary so much that almost each one sounds different from the next. Thus, the values of the resonant frequency in the table are rounded to the nearest 100 Hz. Also note that peaks become very flat and large below 1,000 Hz. As the height of the resonance peak depends on the external load resistance (volume pot, tone pot and amplifier input resistance), lowering this load (e.g. by switching resistors in parallel to the pickup) lowers the height. For raising the height of the peak, the load resistance must be increased. In many cases this is only possible by installing a FET or other high-impedance preamp in the guitar.

See table: [Resonant frequencies of some well-know pickups for various parallel capacitors](#)

4. Install an active electronic circuit that acts as a second-order low-pass filter. This will give you the possibility to adjust the resonant frequency and the resonance height continuously with potentiometers, instead of only in discrete steps. So you can imitate the sound characteristics of many different guitar and bass pickups. These circuits are called „State Variable Filter". The first instrument manufacturer to apply this was Alembic since the seventies, later it was copied by others. Completely mounted circuit boards of this kind, fitting into most common instruments, are available from the author (Fig. 7). They need a 9 V battery for supply, and on some instruments some space inside the body that must be routed.

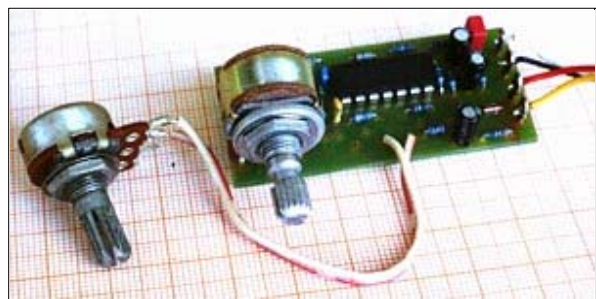

Fig.7. Active electronic circuit that acts as a second-order low-pass- filter and imitates the sound characteristics of many different guitar and bass pickups

Measuring Frequency Response

To precisely measure a pickup's frequency response, it would be necessary to measure the vibration of the string and compare it with the output voltage at every frequency. In practice, this is very difficult to do. An alternative to moving the string is to subject the pickup to an outside magnetic field, generated by a transmitting coil. This

induces a voltage by changing the magnetic flux through the coils. As the induced voltage in the pickup is proportional to the variation of the magnetic field with time, the driving current through the coil must be inversely proportional to the frequency.

A sine wave voltage feeds an integrator circuit to produce an output voltage that is inversely proportional to frequency. This signal then goes into a power amplifier and then to the transmitting coil that actually couples the signal into the pickup. The coil can consist of a pickup bobbin wound with about 50 turns of enamelled copper wire (approximately 0.5 mm, or 0.02 inches in diameter, no. 24). The exact value is not critical. The coil must be driven with a constant current independent of its impedance. It is mounted above the pickup so that it radiates its magnetic field into the pickup coil(s) as fully as possible. With single coil pickups, the axes must be in line with each other; with humbucking pickups, the axis of the transmitting coil must be perpendicular to the axes of the pickup's coils (Fig. 8).



Fig.8. A transmitting coil radiates its magnetic AC field into the pickup coils. So you can measure the frequency response easily

To plot the response, vary the sine wave frequency from about 100 Hz to 10 kHz and measure the pickup's output voltage with a broad-band multimeter or oscilloscope. The absolute value is not important; what matters is the position of the resonance peak and its height above the overall amplitude at lower frequencies. The effect of different load capacitors (cables) and resistors (pots) is easy to examine with this setup. One of the main advantages of this measuring method is that no modifications on the guitar are necessary, and the pickups need not be removed from the guitar.

This complete measuring arrangement is now available as a commercial instrument. With this, you can easily see what a pickup does with the sound material it gets from strings and body. This is the end of wandering around in the fog. The Pickup Analyzer[©] (Fig. 9) determines the frequency response, it shows which frequencies are emphasized and which are attenuated - objectively, independent of strings and body, with mounted or loose pickups. How it works: A transmitting coil radiates an alternating magnetic field into the coil(s) of the pickup. While the frequency is varied over the entire audio range, the instrument measures the output voltage of the pickup. The external load conditions can be varied over a wide range: 11 capacitors from 40 pF to 10 nF and four resistors from 125 kOhm to 1 MOhm. Also, the combination of a pickup with a guitar cable can be measured, the influence of different cables on the response is plain to see. Furthermore, it is possible to analyze any modifications on a pickup, such as removing the metal cover or exchanging the magnets for others, or technical defects like short-circuit windings inside the coil. Sample variations of the pickup series can be recognized quickly, deviants can be identified and sorted out. So reclaiming from the manufacturer will have a better chance. The Pickup Analyzer[©] saves time in development and repairs. Main users are pickup manufacturers, high quality guitarmakers and renowned music shops.



Fig.9. The "Pickup Analyzer"[©] - the first commercially available measuring instrument for the frequency response of magnetic pickups.

The measured result is really precise only for single coil pickups. Humbucking pickups have certain notches at high frequencies, because the vibrations of the strings are picked up at two points simultaneously. High overtones, where the peak of the waveform occurs over one pole and the trough (valley) of the wave occurs over the other, can produce cancellations. These notches are at different frequencies for each string and cannot be described with a single curve. For instance, with standard size humbucking pickups, for the deep E string the notch is at about 3,000 Hz, for the A string at 4,000 Hz. For the high strings the notch is far above the cutoff frequency f_g and can hardly be heard.

The effect of the sound difference between one coil and two coils with a humbucker is overestimated by far. The main reason for getting more treble with one coil is that the resonant frequency has been raised because of the halving of the inductance. Sensing the strings at only one point instead of two also has an effect, but this is much smaller. It can only be compared when the resonant frequency is held constant while switching.

Furthermore, this measuring method does not take into consideration the effect of different output voltages of different pickups. In the „crunch" range of a tube amp a loud pickup produces a different tone than a low volume pickup, even when their transfer characteristics are equal. Nevertheless, testing a pickup in this manner gives useful information on its characteristics. With this knowledge, you can find which type of sounds appeal to you the most, and possibly bend and shape the frequency response with external capacitors and resistors to "tune" pickups to your liking (and for the best match to the body and strings).

Finally, the nonlinear distortion of a pickup cannot be measured in this way. It exists, because the relationship between the magnetic flux through the coil(s) and the distance from the magnetic pole to the string follows a hyperbolic curve. So, if the string vibrates in a sine wave (which every harmonic does by itself), additional even harmonics are produced which do not exist in the natural spectrum of the vibration, and as a consequence alter the sound. The resulting distortion depends on the width of the string vibration and can hardly be quantified. The shorter the distance between magnetic pole and string, the stronger it is. This can be heard: With a shorter distance, the sound is more aggressive than with a larger distance. But with too short a distance, the magnets pull the strings, and harmonics are shifted so that they are no longer exact multiples of the fundamental frequency, but a little higher or lower. If this variation is very small, it can sound good and the tone becomes more alive, like with a slight chorus effect. But if it is too large, the sound will be terrible. You will find this problem on many Stratocasters, it is called "Stratitis". The only way to reduce it is to adjust the pickup to be further away from the strings.

© Helmuth E. W. Lemme, Munich, Germany

<http://www.gitarrenelektronik.de>

Pickup Central

Over 25 brands of pickups Guitar, bass, violin, banjo, more
www.pickupcentral.com

Inductors & Coils

Search by Mounting Type, Inductance Core Material. Same Day Shipping!
www.digikey.com

Pickups price

Dealers Reveal Their Low Price Our Secret Formula Saves Thousands
www.SecretAutoPrice.com

2006/7 pickups

Deep Discounted General Deals Save \$1000s with Free Quote & Info
www.NewCarInsider.com

If you need competent and in-depth information about electric guitar pickups ask the German guitar electronics expert and author *Helmuth Lemme*. He wrote a German book on guitar electronics and shares some of his knowledge in the following article.

Diesen Artikel und noch mehr gibt es in deutscher Sprache unter www.gitarrenelektronik.de