

ECHO UNIT

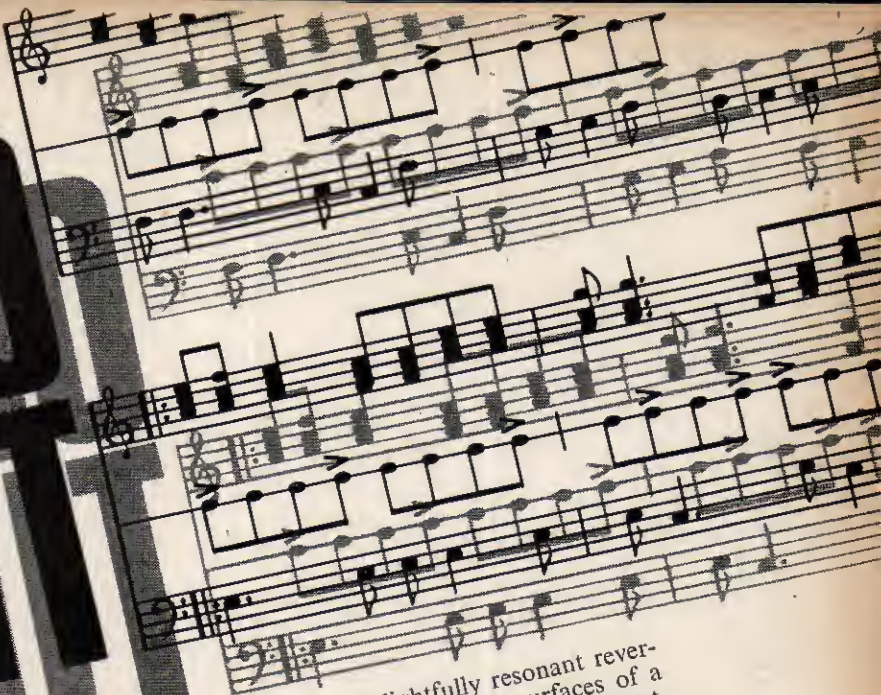

We have all experienced the "Bathroom Effect", that delightfully resonant reverberation added to the voice or an instrument by the hard reflecting surfaces of a sparsely furnished room such as a bathroom. The apparent improvement, occurring a small but definite time interval after the original sound. Such echoes have of course been from time immemorial a source of fascination and pleasure to man.

Controlled echoes, which can be produced in a variety of ways, can be put to many uses; for example, adding a new dimension to a solo instrument such as a guitar or saxophone, creating "Radiophonic" or electronic music, adding dramatic sound effects to plays and film sound tracks, or even improving the musical efforts of pop or beat groups.

Since it is hardly practicable to carry around a portable bathroom or echo chamber, the author designed and constructed the instrument to be described, by means of which a controlled echo or series of echoes can be added to any audio signal. Emphasis in the design was given to reliability and mechanical simplicity, and ease of construction, and as can be seen from the accompanying photograph the instrument is very compact and easily portable.

by **A.T.J. Carrington**

This is the completed echo unit. The side and bottom panels can be detached leaving the electronic—mechanical assembly fully exposed.

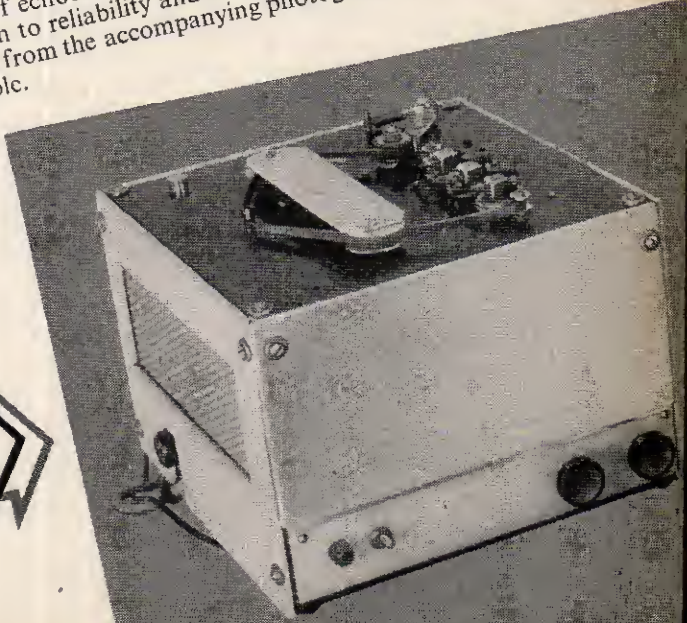

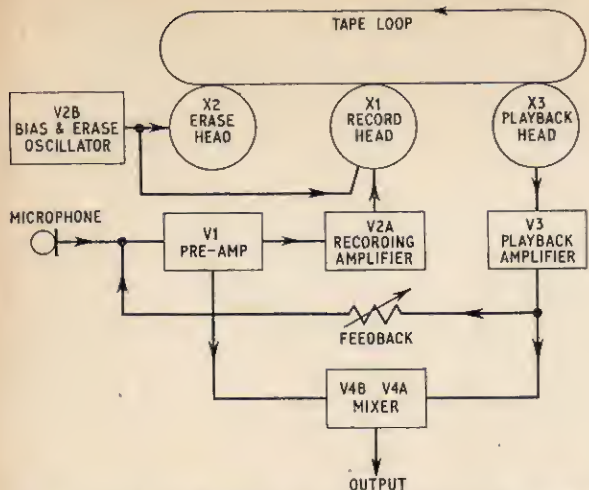

Fig. 1. This block diagram makes clear the system used in the echo unit

THIS instrument uses the endless tape loop method of producing echoes, and in effect is a specialised form of tape recorder. Reference to Fig. 1 should make the operating principles clear.

The signal, from a microphone or other source, is fed to the pre-amplifier, stage V1, the output from which is split into two parts. Part of the signal is fed to the recording amplifier, V2A and thence to the recording head X1 where it is recorded on the tape loop. The other part of the signal from V1 is fed to a mixer stage, V4B, and thence to the output socket of the unit, so the original signal is amplified and passed straight through the unit and can be applied to the equipment desired.

The recorded signal on the tape is picked up by the playback head X3 and fed into the playback amplifier V3, and thence to the mixer V4A, where it is mixed with the original signal, both signals appearing at the output.

So we now have the original signal plus a single echo, the time lag being dependent on the speed of the tape loop and the distance between the heads. A single echo is not very effective however, and so if we feed back part of the amplified echo from the playback amplifier V3 to the first amplifier V1 the *echo* will go through the whole process again and again and so we will end up with the original signal plus a whole series of echoes, which can, by suitable adjustment of the feedback control, be made to gradually fade away into silence, considerably enhancing the effect.

THE CIRCUIT

Fig. 2 shows the complete circuit diagram of the echo unit.

V1, an EF86 low noise pentode, is the pre-amplifier. Part of the output from V1 anode is fed via C4 and R8 to the preset recording level control VR1 which determines the level of signal fed to the triode grid of V2. The triode section of this valve (V2A) is the recording amplifier, and the pentode section (V2B) is used as the bias and erase oscillator.

V3, another EF86, is the playback amplifier, and the output from this stage is fed via C16 and the playback gain control VR3 to the grid of V4A.

The second triode section of this valve (V4B) is fed from V1 anode via C5, R7 and VR4, gain being adjusted by the latter preset control. The echo feedback is applied via VR2, which controls the amplitude of the amplified echoes from V3 that are fed back to the grid of V1.

The full wave rectifier V5 provides h.t. which is well smoothed and decoupled by C1, C14, C18, C12 and C13 in conjunction with the associated resistors.

TAPE TRANSPORT MECHANISM

As was mentioned before, emphasis was given to simplicity of construction, and the tape transport mechanism consists simply of a square mild steel plate on which are mounted the three heads (erase, record and playback), the tape guides, and a motor.

The motor is an induction type similar to those used in record players. The shaft of this motor forms the capstan which in conjunction with a rubber faced pinch wheel draws the tape past the heads at a speed of approximately 12.5in/sec. In this way, no pulleys, belts or other mechanical parts are required, and the author found this method entirely satisfactory, wow and flutter being well within tolerable limits. Two spring loaded pressure pads are also mounted to keep the tape in intimate contact with the heads.

AMPLIFIER CONSTRUCTION

The electronics were mounted by conventional methods on an aluminium chassis measuring 10in x 10in x 2.5in, components being mounted directly onto valveholders with insulated anchor tags being used where necessary. The arrangement of the larger components is shown in Fig. 3. Layout is not critical but care must be taken to screen the oscillator stage; this was done in the prototype by making a rectangular box from strip aluminium and bolting this to the chassis, the oscillator components being mounted in the box.

The mains transformer should be mounted as far away from the playback head as possible, but owing to the shielding effect of the mild steel baseplate, the author was not troubled by any problems of induced mains hum.

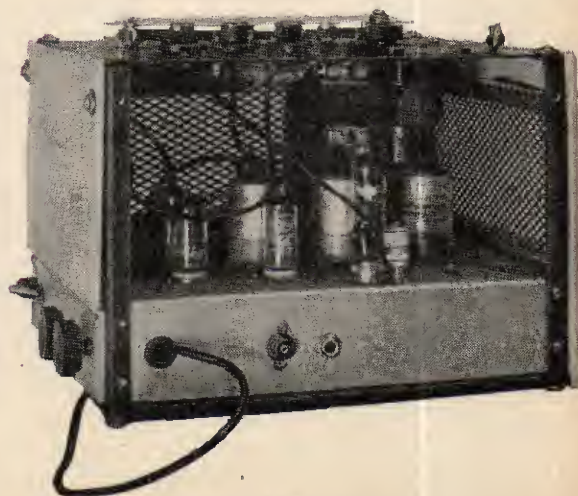

Interior of the echo unit

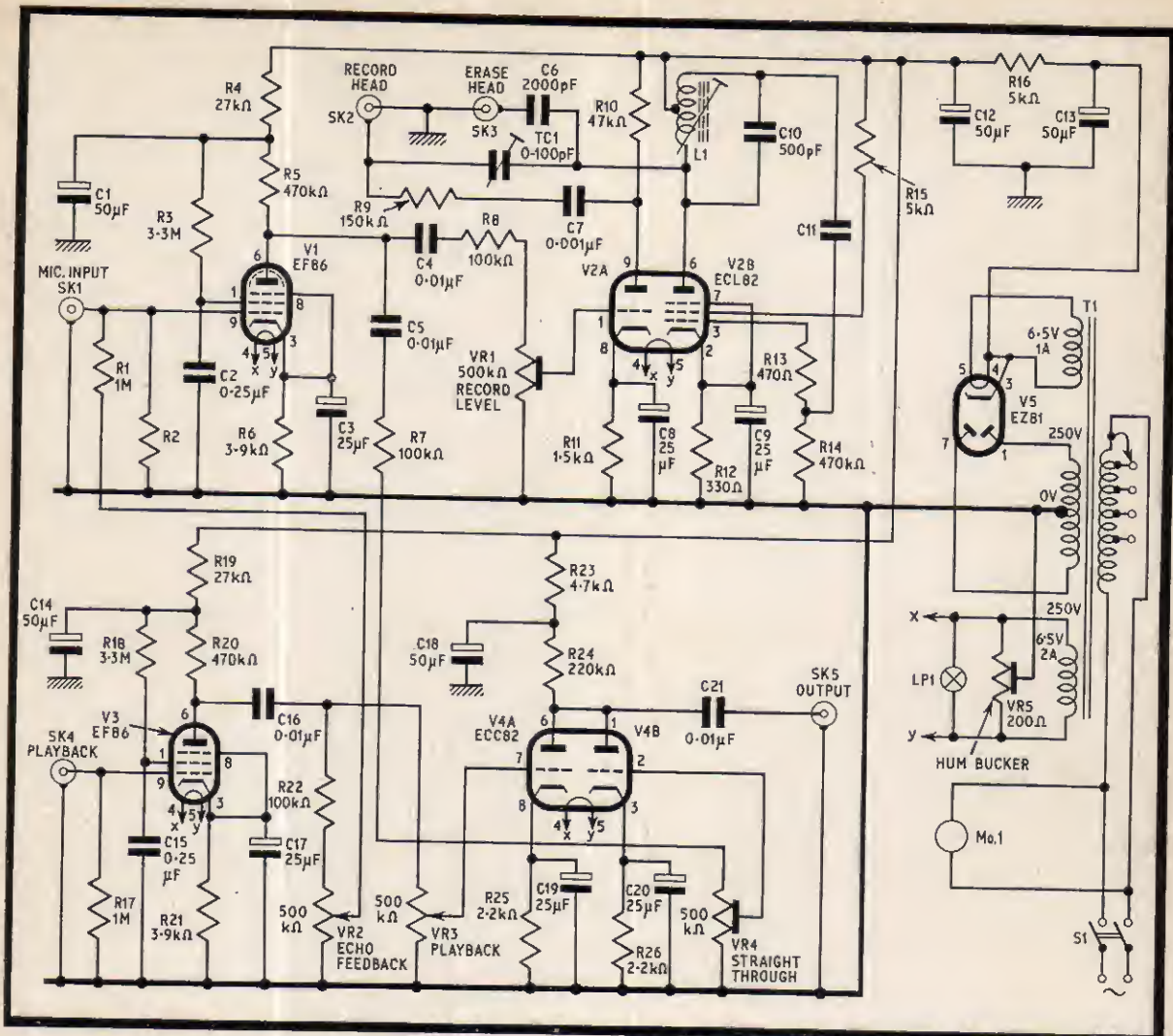

Fig. 2. The complete circuit diagram for the echo unit

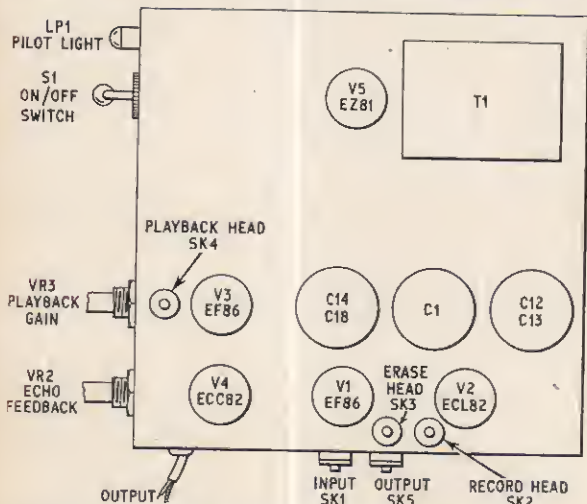

Fig. 3. Top view of the electronic chassis showing the positions of all the major components

The two controls, (playback volume and echo feedback), a pilot light, and a separate on/off switch were mounted on the front of the chassis, a piece of white perspex retained by the control securing nuts forming the front decor.

The input socket was mounted on the side of the chassis as near V1 as possible to minimise the risk of hum.

Ordinary valveholders were used but antimicrophonic valveholders for V1 and V3 could be advantageous. Three chassis mounting coaxial sockets were used to connect the three heads, thus permitting the amplifier to be removed as a separate unit.

TAPE DECK CONSTRUCTION

The tape mechanism was constructed on a piece of 16 s.w.g. mild steel plate, finished in black crackle after drilling. The size of the plate was 10in x 10in and drilling details are given in Fig. 4.

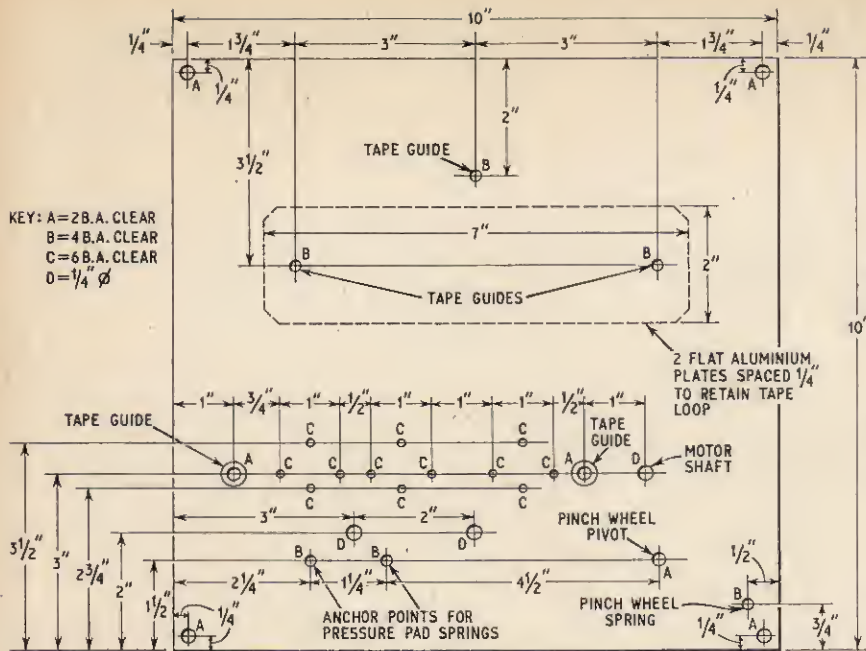
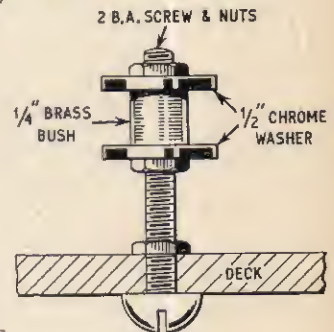

Fig. 4 (left). A plan view of the tape deck showing drilling dimensions

Fig. 5. Details of the tape guides. Five of these are required



The motor was bolted directly to the underside of the plate, the shaft projecting through a hole drilled for the purpose. The three heads, all high impedance, were of the Mariott type as used in the B.S.R. Monardeck, and were mounted on wedge shaped bases so that they could be individually adjusted for azimuth alignment. The distance between the erase and record heads is unimportant, but the playback head should be approximately 2in from the record head in the direction of tape travel.

The tape guides were made from $\frac{1}{4}$ in brass bushes with a chrome washer top and bottom mounted on a 2B.A. stud. See Fig. 5. These guides were screwed into tapped holes in the deck and secured with a locking nut being adjusted so that the tape ran parallel to the deck.

The pinch wheel, which can be of any diameter, was mounted on a pivoted mild steel arm, held firmly against the motor shaft by a $2\text{in} \times \frac{1}{4}$ in steel spring. This spring is removed when the instrument is not in use, to prevent "flats" forming on the pinch wheel. Details of the pinch wheel appear in Fig. 6.

The two pressure pads each consist of a piece of thick felt cemented to a piece of $\frac{1}{4}$ in brass strip, the latter being soldered to a $\frac{3}{8}$ in shaft which passes through a bush in the deck, see Fig. 7. To the lower end of the shaft is soldered a 2B.A. tag which carries a light tension spring. The other end of this spring is anchored to a 6B.A. bolt in the deck plate. The tension of each spring should be adjusted so that the tape is kept snugly against the heads. Too much tension will cause excessive tape head wear. The erase head, having a much wider gap, needs no pressure pad as long as the tape is in contact with the head.

The tape loop itself was about 20in long but this is not at all critical. In order to keep the loop in position, two flat aluminium plates separated by $\frac{1}{4}$ in bushes were mounted on the deck so that the loop was kept in slight tension. Incidentally, the loop wears extremely well—the author is still using the original, eighteen months after constructing the instrument!

CABINET

The author, not being a particularly good joiner, evolved the following method of housing the instrument. A double decker form of construction was used, the chassis being bolted to four uprights, each 7.5in long and made from $\frac{1}{2}$ in angle iron. The top and bottom of each upright were bent over and drilled and tapped to take 2B.A. screws (see Fig. 8).

The tape deck was then screwed to the top of the uprights and a plywood base with four rubber feet fixed to the bottom of the uprights.

The sides of the uprights were again drilled and tapped 2B.A. and hardboard panels covered in white vinyl cloth with a cutout covered by gold anodized fret were screwed to the uprights. This resulted in a neat cabinet with side panels and bottom being easily detached for easy access to the interior. A lid was constructed from hardboard cemented to four $1\frac{1}{2}$ in \times $1\frac{1}{2}$ in battens, the whole being covered with white vinyl.

SETTING UP AND TESTING

The setting up process is made easier by virtue of the fact that the result of any adjustment is immediately audible via the playback amplifier.

First of all it is necessary to adjust the tape guides so that the tape is drawn easily past and parallel with the tape heads. The author used a commercial test tape to make the head azimuth adjustment, but it is quite easy to line them up without. To do this, first align the record head visually so that the head gap is as nearly as possible at right angles to the tape; do this by slackening one screw and tightening the other so the head rocks about the wedge shaped base.

The erase and playback heads cannot be adjusted until the amplifier has been set up. Start by setting all preset controls and the echo feedback control to minimum. Advance the playback control about three quarters towards maximum, and feed a suitable signal into the input socket.

Components . . .

Resistors

R1 1M Ω	R10 47k Ω	R19 27k Ω
R2 1M Ω	R11 1.5k Ω	R20 470k Ω
R3 3.3M Ω	R12 330 Ω 1W	R21 3.9k Ω
R4 27k Ω	R13 470 Ω	R22 100k Ω
R5 470k Ω	R14 470k Ω	R23 4.7k Ω
R6 3.9k Ω	R15 5k 5W	R24 220k Ω 1W
R7 100k Ω	R16 5k Ω 10W	R25 2.2k Ω
R8 100k Ω	R17 1M Ω	R26 2.2k Ω
R9 150k Ω	R18 3.3M Ω	

All $\pm 10\%$, $\frac{1}{2}$ W carbon, unless otherwise stated.

Valves

V1 EF86	V3 EF86
V2 ECL82	V4 ECC82
V5 EZ81	

Inductors

L1 Oscillator coil, 45kc/s.
T1 Mains transformer. Secondaries: 250-0-25V 70mA; 6.5V 2A; 6.3V 1A (Radiospares "Economy" type)

Switch

S1 Double pole on/off switch

Sockets

SK1-5 Coaxial socket, chassis mounting (5 off)
--

Lamp

LPI 6V lamp

Capacitors

C 1 50 μ F elect. 350V	C12 50 μ F elect. 350V
C 2 0.25 μ F paper 500V	C13 50 μ F elect. 350V
C 3 25 μ F elect. 25V	C14 50 μ F elect. 350V
C 4 0.01 μ F paper 500V	C15 0.25 μ F paper 500V
C 5 0.01 μ F paper 500V	C16 0.01 μ F paper 500V
C 6 2,000pF ceramic	C17 25 μ F elect. 25V
C 7 1,000pF ceramic 500V	C18 50 μ F elect. 350V
C 8 25 μ F elect. 25V	C19 25 μ F elect. 25V
C 9 25 μ F elect. 25V	C20 25 μ F elect. 25V
C10 500pF silver	C21 0.01 μ F paper 500V
C11 1,000pF ceramic 500V	TC 1 0-100pF preset trimmer

Potentiometers

VR1 500k Ω carbon, preset	VR4 500k Ω carbon, preset
VR2 500k Ω carbon, log	VR5 200 Ω wirewound, preset
VR3 500k Ω carbon, log	

TAPE DECK

Record/Playback Head with mounting plate	A102874
Erase Head with mounting plate	A102875
Pinch Wheel Assembly	A102821

The above items are as used in the B.S.R. Monardeck and are obtainable (via retailer) from:
Elstone Electronics, Edward St., Templer St., Leeds 2.

Mo.1. A.C. Induction Motor, obtainable from:
Radio and T.V. Components (Acton) Ltd.,
21A High St., Acton, London W.3.

Other parts of the deck are made as described in the text.

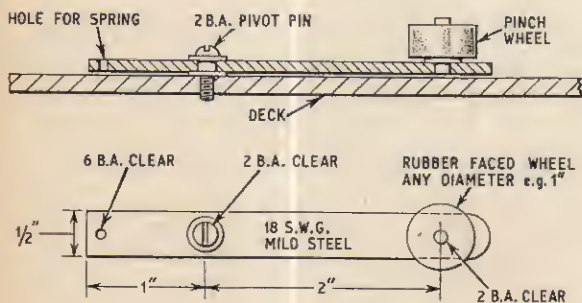

Fig. 6 (left). The pinch wheel mechanism, side and plan views

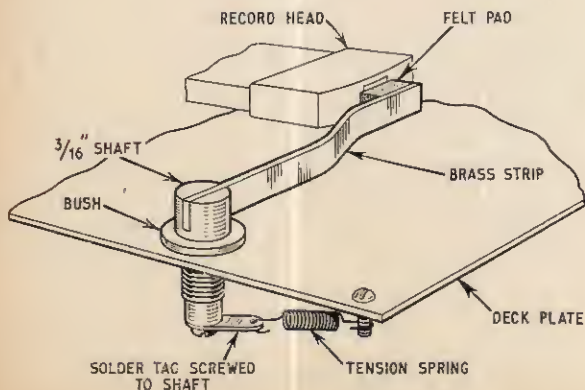

Fig. 7 (left). Detail of the pressure pad assemblies. Two of these are required



Fig. 8 (right). Detail of cabinet supports. Four are required

continued on page 793