

Dual-slope filters optimize speaker's crossover response

by P. Antoniazzi and A. Hennigan
SGS-ATES Electronic Components, Milan, Italy

The crossover response, and thus the overall performance, of a two-way high-fidelity loudspeaker system can be significantly improved with these high- and low-pass networks. Staggering two cascaded RC filters in the woofer channel yields a slope of 6 dB/octave near the cutoff frequency, f_c , and a notably steeper 12 dB/octave beyond f_c . When combined with the complementary (inverted response) output of the tweeter section, optimum crossover characteristics are achieved at low cost and without audio-frequency discontinuities at f_c .

In general, many simple low-pass networks can provide a 6-dB/octave response at frequencies approaching f_c from the low side. When a single-pole filter is used, however, as is still done on occasion, the maximum roll-off beyond f_c can never be greater than 6 dB/octave. Unfortunately, the typical loudspeaker does not have a linear enough response to handle high-level signals (de-

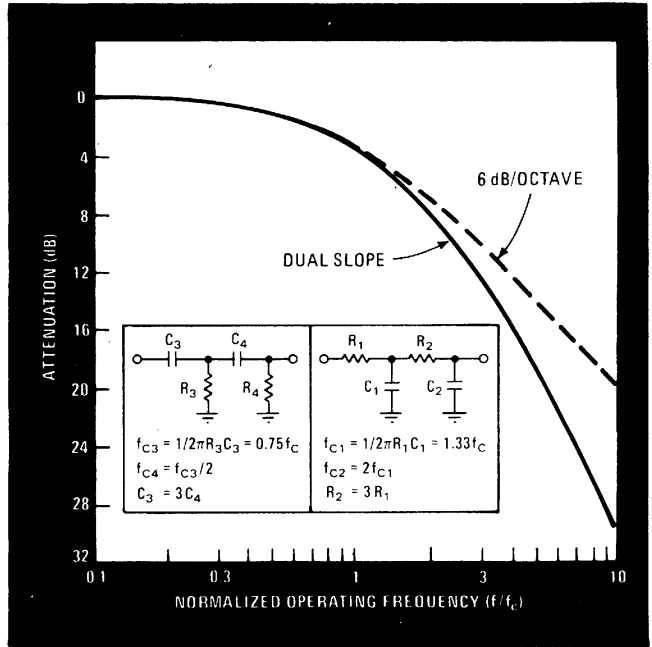

2. Response. Dual-slope filter, using staggered RC networks, virtually eliminates drop-off in audio output at the cutoff frequency of hi-fi speakers, while providing a roll-off of greater than the usual 6 dB/octave. Equations for woofer and tweeter sections summarize design.

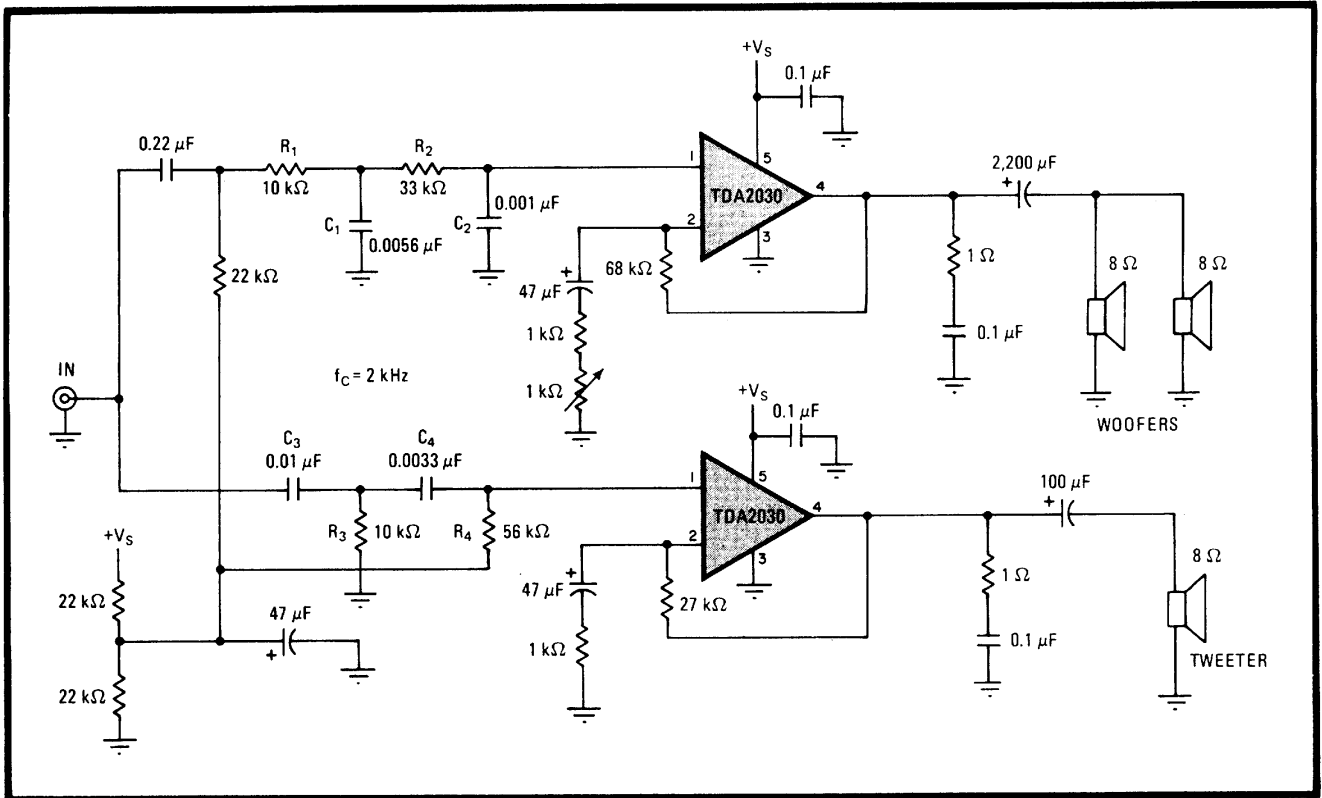

1. Distortionless. Staggered low-cost, low-pass filters in woofer channel achieve slope of 6 dB/octave approaching cutoff frequency f_c and 12 dB/octave above f_c without introducing quadrature phase shift and accompanying distortion produced by loudspeakers. When combined with complementary output of high-pass section, system achieves crossover characteristic devoid of audio discontinuities at f_c .

graded by only 6 dB/octave) at its high-frequency limits, and so distortion results.

With second-order filters (12 dB/octave), a loss of audio usually occurs at the crossover point. This phenomenon is caused by the $+90^\circ$ phase shift of the low-pass network, which when combined with the -90° output of the system's high-pass filter tends to cancel the audio output.

Using a third-order Butterworth filter solves both of the aforementioned problems, yielding a flat response from dc to near f_c , steep cutoff (18 dB/octave) above f_c , and a gradual phase change across the band of interest. But this method is expensive, requiring two or three op

amps and a large number of external components.

The dual-slope crossover network (Fig. 1) provides a viable answer to the problem. Stagging the responses such that the cutoff frequency of the first RC network is one half that of the second, attenuation at the crossover frequency will be 3 dB as in other systems, but the phase shift at f_c will be 60° ; thus the cancelation problem typical of second-order filters is avoided. This circuit is ideally suited to active loudspeaker systems.

The plotted response of the woofer section is shown in the curve, which is complete with the required design equations. Corresponding equations for the tweeter are also included. \square