

# LINKWITZ LAB

Sensible Reproduction and Recording of Auditory Scenes

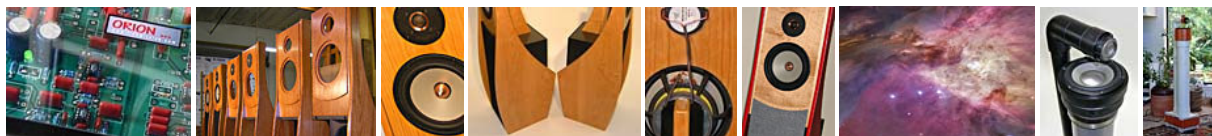

Build your last loudspeakers yourself or let Wood Artistry build them for you



## PHOENIX ...

| [Build-Your-Own](#) | [Main Panel](#) | [Dipole Woofer](#) | [Crossover/EQ](#) | [Supplies](#) |  
| [System Test](#) | [Design Models](#) | [Prototypes](#) | **Active Filters** | [Surround](#) | [FAQ](#) |

## Active Filters

### What's new

[HOME](#)

### Products

[ORION - PLUTO](#)  
by Wood Artistry

[ORION - EU](#)

[ORION - BR](#)

[ORION - PLUTO](#)  
by the sea

[Do-It-Yourself](#)

Here is a catalog of line-level circuits that I have found useful for building active loudspeakers. Many other topologies are possible, but one should always analyze a circuit's signal handling capability and its contribution to overall system noise before choosing it. A CAD software package such as [CircuitMaker](#) is most convenient for analyzing and designing active filters. [LspCAD](#) software allows you to see how an active filter changes the measured frequency response of a driver and lets you optimize it to a target response. All the line level filters below are included in LspCAD standard and professional versions. Component values for all the filters below and for a dual power supply can be determined from a [circuit design spreadsheet](#) contributed by [Bernhard Faulhaber](#). It covers more cases than the earlier [spreadsheet](#) by [Alister Sibbald](#).

- [1](#) - Buffer stage
- [2](#) - 12 dB/oct Linkwitz-Riley crossover
- [3](#) - 24 dB/oct Linkwitz-Riley crossover
- [4](#) - Delay correction
- [5](#) - Shelving lowpass & passive circuit
- [6](#) - Shelving highpass & passive circuit
- [7](#) - Notch filter
- [8](#) - 6 dB/oct dipole equalization
- [9](#) - 12 dB/oct highpass equalization ("Linkwitz Transform", Biquad)
- [10](#) - Variable gain & fixed attenuation
- [11](#) - Line driver
- [12](#) - Power supply
- [13](#) - Printed circuit boards
- [14](#) - Literature

### Concepts

[Accurate Stereo](#)

[Loudspeakers](#)

[Crossovers](#)

[Room acoustics](#)

[Sound reproduction](#)

[Room optimized stereophonic reproduction](#)

[Recording for stereo](#)

[Design of loudspeakers](#)

[Issues in speaker design](#)

#### 1 - Buffer stage

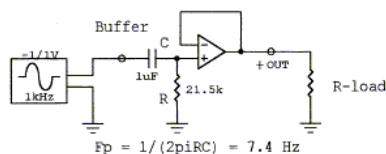

A buffer as the first stage of an active crossover/equalizer provides the necessary low source impedance to the following filter networks. The buffer also provides a high impedance load to the preamplifier output circuit and the option of a highpass filter for dc blocking. ([w-xo-lp2.gif](#), [pmtm-eq1.gif](#), [38xo\\_eq.gif](#)) [Top](#)

#### 2 - 12 dB/oct Linkwitz-Riley crossover

**Projects**

- [ORION challenge](#)
- [ORION-3.3](#)
- [PLUTO-2.1](#)
- [PLUTO+ subwoofer](#)
- [THOR subwoofer](#)
- [PHOENIX dipole speaker](#)
- [Active filters](#)
- [Microphone](#)
- [FAQ](#)
- [Three-Box active system \(1978\)](#)
- [Reference earphones](#)
- [Surround sound](#)
- [Loudspeaker evaluation](#)

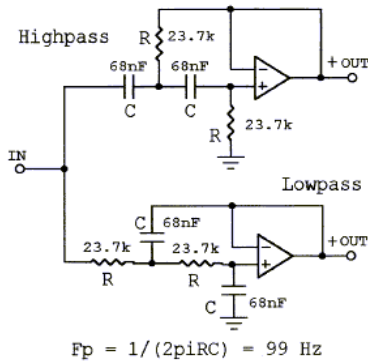

The two outputs from the [LR2 crossover filter](#) are 180 degrees out of phase at all frequencies, which requires to use one of the drivers with reversed polarity, so that the two acoustic outputs add in phase. At the crossover frequency the filter outputs are 6 dB down.

The acoustic frequency and polar response is controlled by the electrical filters and the response of the mounted drivers. The electrical filter will not give the desired results, if there is insufficient overlap and flatness of the driver frequency response and when they are offset from each other. This can be corrected in many cases with the addition of a phase shift correcting network. I consider the crossover marginally useful, because the 12 dB/oct roll-off of the highpass filter below the crossover frequency does not reduce the excursions of a driver's cone when flat frequency response is obtained. My earlier assumption that the [group delay](#) of a 4th order LR4 crossover at low frequencies would introduce audible distortion was not correct. Therefore I recommend not to use the LR2 crossover. ([38xo\\_eq1.gif](#), [FAQ19](#), [xo12-24b.gif](#))

The LR2 circuit uses the Sallen-Key active filter topology to implement the 2nd order transfer function. The response is defined by  $\omega_0$  and  $Q_0$  which sets the location of a pole pair in the [complex frequency s-plane](#) and by an additional two zeros at  $s = 0$  for the highpass filter. In the case of the LR2 filters  $Q_0 = 0.5$ , and  $Q_0 = 0.71$  for each of the two cascaded 2nd order filters that form the LR4 filter. The frequency response is obtained by setting  $s = j\omega$  and solving the transfer function for magnitude and phase. The formulas below can be used to design filters with different values for  $\omega_0$  or  $Q_0$ , or to analyze a given circuit for its  $\omega_0$  and  $Q_0$  values.

**Resources**

- [Website CD](#)
- [Toneburst CD](#)
- [Demo CD](#)
- [Publications](#)
- [Music](#)
- [Links](#)
- [Other designs](#)
- [Site map](#)
- [My current setup](#)
- [About me](#)

1) Lowpass transfer function (2nd order)

$$L(s) = \frac{\omega_0^2}{s^2 + \frac{\omega_0}{Q_0}s + \omega_0^2}$$

$\omega_0 = 2\pi f_0$   
 $s = \sigma + j\omega$

2) Circuit configuration

$\omega_0 = \frac{1}{R\sqrt{C_1 C_2}}$   
 $Q_0 = \frac{1}{2} \sqrt{\frac{C_1}{C_2}}$   
 $R = \frac{1}{2Q_0 \omega_0 C_2}$   
 $C_1 = 4Q_0^2 C_2$

$Q_0 = 0.5$  LR2  
 $Q_0 = 0.71$  LR4 (2 stages)

2/25/05 RL

**Conclusions**

1) Highpass transfer function (2nd order)

$$H(s) = \frac{s^2}{s^2 + \frac{\omega_0}{Q_0}s + \omega_0^2}$$

$\omega_0 = 2\pi f_0$   
 $s = \sigma + j\omega$

2) Circuit configuration

$\omega_0 = \frac{1}{C\sqrt{R_1 R_2}}$   
 $Q_0 = \frac{1}{2} \sqrt{\frac{R_2}{R_1}}$   
 $C = \frac{2Q_0}{\omega_0 R_2}$   
 $R_1 = \frac{R_2}{4Q_0^2}$

$Q_0 = 0.5$  LR2  
 $Q_0 = 0.71$  LR4 (2 stages)

2/25/05 RL

[HOME](#)

Any order [Linkwitz-Riley filters](#) can be implemented by a cascade of 2nd order Sallen-Key filters. The  $Q_0$  values for each stage are listed in the table below. The component values of each stage for a given crossover frequency  $f_0$  can be calculated by using  $Q_0$  and selecting a convenient value for  $C_2$  or  $R_2$  in the formulas above.

	LR2	LR4	LR6	LR8	LR10
$Q_0$ of stage 1	0.5	0.71	0.5	0.54	0.5

-----  
[ORION](#)  
[PLUTO](#)  
[Users Group](#)

Q <sub>0</sub> of stage 2		0.71	1.0	1.34	0.62
Q <sub>0</sub> of stage 3			1.0	0.54	1.62
Q <sub>0</sub> of stage 4				1.34	0.62
Q <sub>0</sub> of stage 5					1.62
dB/octave slope	12	24	36	48	60

LINKWITZ  
RENTALS

Crossover filters of higher order than LR4 are probably not useful, because of an increasing peak in group delay around  $f_0$ .  
[Top](#)

### 3 - 24 dB/oct Linkwitz-Riley crossover

Digital Photo  
Processes

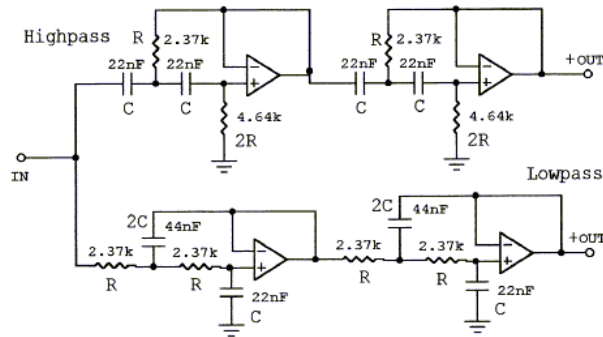

$$F_p = 1 / (2.83\pi RC) = 2158 \text{ Hz}$$

What's new

The 24 dB/oct [LR4 crossover filter](#) provides outputs which are 360 degrees offset in phase at all frequencies. At the transition frequency  $F_p$  the response is 6 dB down. The electrical network will only give the targeted exact acoustic filter response, if the drivers are flat and have wide overlap. This is seldom the case. The steep filter slopes make the combined acoustic response less sensitive to magnitude errors in the driver responses, but phase shift errors usually have to be corrected with an additional allpass network. ([xo12-24b.gif](#), [38xo\\_eq1.gif](#), [models.htm#E](#)) [Top](#)



Russ Riley and Siegfried Linkwitz, September 2006, Douglas City, CA

*In the sixties, early seventies, I worked with Russ Riley at Hewlett-Packard's Palo Alto R&D laboratory for the development of RF and Microwave test equipment. Like many other engineers we had "G-Jobs", building such things as electronic ignitions for our VW bugs and vans, FM receivers, phase-locked pulse width FM demodulators, short-wave receivers, audio pre- and power amplifiers, third octave audio analyzers, headphone equalizers, and of course, loudspeakers. After measuring the acoustic and electrical responses of commercial speakers we equalized them and tried to understand why they were designed with strange looking driver layouts, used large baffles, were stuffed with a variety of internal damping materials and used various box stiffening and damping techniques. Eventually we completely redesigned them and built our own speakers. Russ and his wife, Vicky, an accomplished organist, always had the most critical and reliable ears. He was an ingenious design engineer, a strong contributor, who inspired and challenged many of us on our HP and unofficial design projects.*

*Russ retired after over 40 years in R&D for HP/Agilent and now lives with his wife in a remote mountain valley, in a genuine log cabin, amongst pear, plum and walnut trees, berry bushes, chicken and deer, the sounds of a large creek, and the pine and fir trees that climb up the slopes. He died peacefully in his log cabin on December 6, 2010.*

### 4 - Delay correction

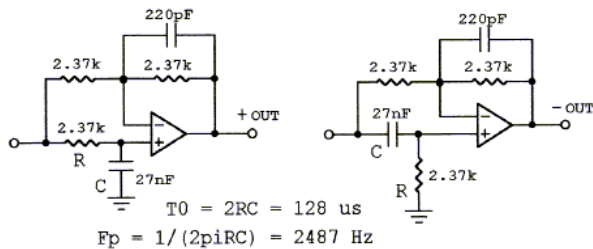

A first order allpass filter section with flat amplitude response but phase shift that changes from 0 degrees to -180 degrees, or -180 degrees to -360 degrees, is often used to correct phase response differences between drivers. Multiple sections may delay the tweeter output and compensate for the driver being mounted forward of the midrange. Active crossover circuits that do not include phase correction circuitry are only marginally useable. ([allpass.gif](#), [allpass2.gif](#), [models.htm#E](#), [38xo\\_eq1.gif](#)) [Top](#)

### 5 - Shelving lowpass

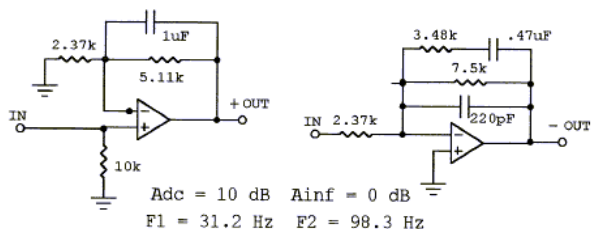

This type of circuit is useful to bring up the low frequency response in order to compensate for the high frequency boost from front panel edge diffraction. It can also serve to equalize the low frequency roll-off from an open baffle speaker. ([shlv-lpf.gif](#), [38xo\\_eq1.gif](#)) [Top](#)

A passive RC version of the shelving lowpass is shown below.

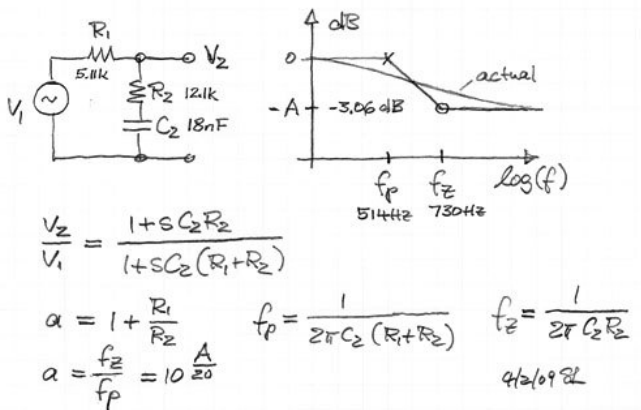

### 6 - Shelving highpass

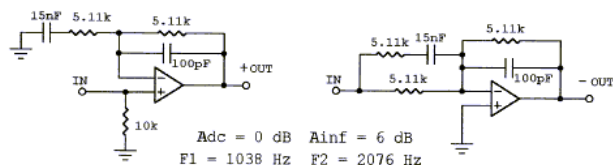

A circuit used to boost high frequencies or to smooth the transition between a floor mounted woofer and a free standing midrange. ([shlv-hpf.gif](#), [38xo\\_eq1.gif](#), [models.htm#F](#)) [Top](#)

A passive RC version of the shelving highpass is shown below.

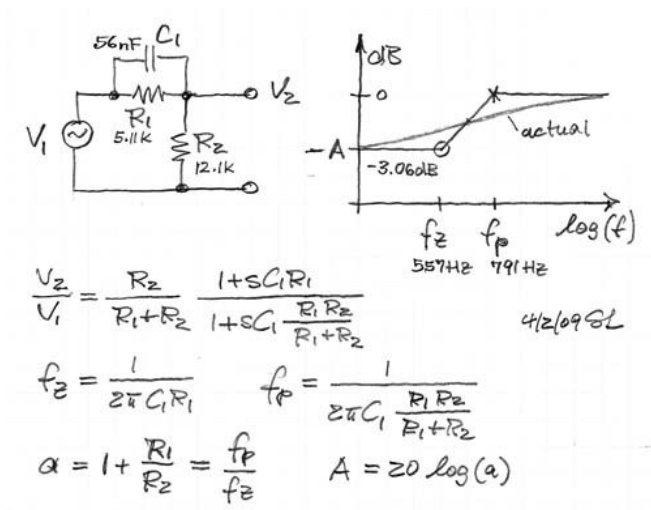

### 7 - Notch filter

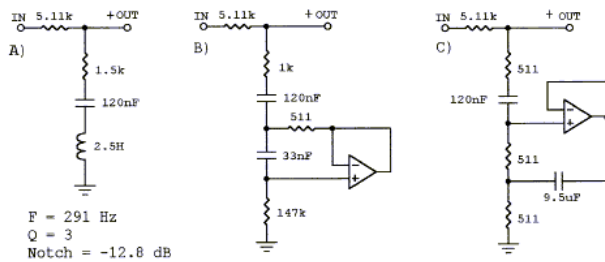

Notch filters are used to introduce dips in the frequency response in order to cancel driver or room resonances. The three circuits above have the same response. A) is difficult to realize because of the large inductor. B) is used to remove the peak in the 6 dB/oct dipole response. C) gives convenient component values for room EQ below 100 Hz. ([room EQ](#), [inductr1.gif](#), [inductr2.gif](#), [38xo\\_eq1.gif](#)) [Top](#)

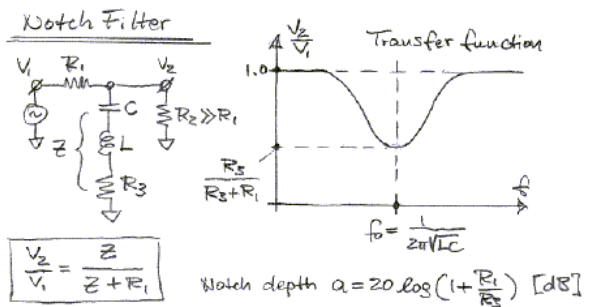

Impedance Z of series-resonant circuit

$$Z = R_3 + j\omega L - j\frac{1}{\omega C} = R_3 + j\frac{\omega}{\omega_0} \omega_0 L - j\frac{\omega_0}{\omega} \frac{1}{\omega_0 C}$$

$$Z = R_3 + j\omega L \left(\frac{\omega}{\omega_0} - \frac{\omega_0}{\omega}\right) \text{ where } \omega_0^2 = \frac{1}{LC} = (2\pi f_0)^2$$

$$|Z| = R_3 \sqrt{1 + Q^2 \left(\frac{f}{f_0} - \frac{f_0}{f}\right)^2} \text{ where } Q = \frac{2\pi f_0 L}{R_3} = \frac{1}{2\pi f_0 R_3 C} = \frac{f_0}{\Delta f}$$

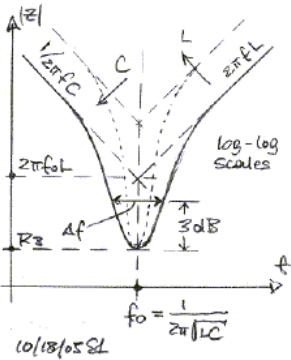

Synthesis

Given:  $R_1$ ,  $\alpha$ ,  $f_0$ ,  $Q$

- 1)  $R_3 = \frac{R_1}{10^{\frac{\alpha}{20}} - 1}$
- 2)  $L = R_3 \frac{Q}{2\pi f_0}$
- 3)  $C = \frac{1}{L (2\pi f_0)^2}$

**8 - 6 dB/oct dipole equalization**

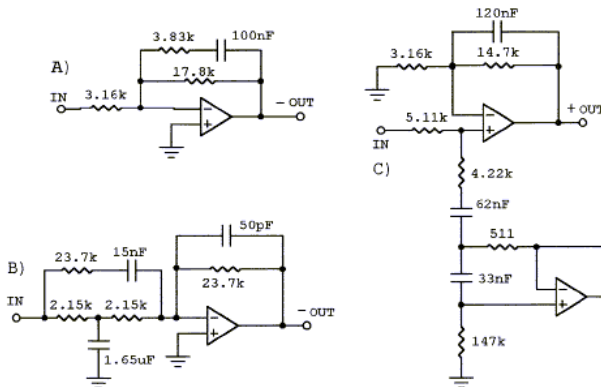

Equalization of the dipole frequency response roll-off usually requires not only a 6 dB/oct boost towards low frequencies, but also removal of a peak in the response. The three circuits differ in their ability to remove such a peak.

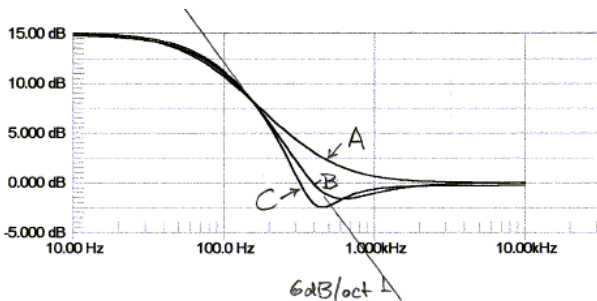

A) The shelving lowpass filter cannot correct for a peak.

- B) The [bridged-T](#) based circuit is limited in the shape of curves that can be realized. It has also higher gain for opamp noise than signal at high frequencies.
- C) The shelving lowpass with added notch filter is the most flexible circuit. ([models.htm#D](#)) [Top](#)

**9 - 12 dB/oct highpass equalization ("Linkwitz Transform", Biquad)**

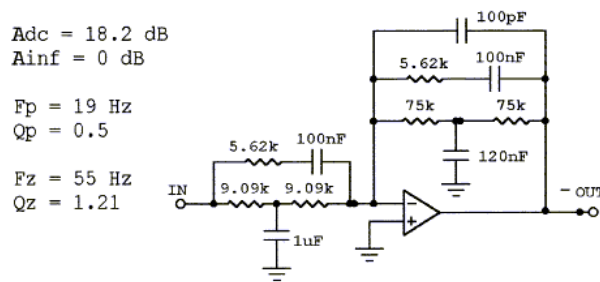

$A_{dc} = 18.2 \text{ dB}$   
 $A_{inf} = 0 \text{ dB}$   
 $F_p = 19 \text{ Hz}$   
 $Q_p = 0.5$   
 $F_z = 55 \text{ Hz}$   
 $Q_z = 1.21$

A majority of drivers exhibit second order highpass behavior because they consist of mechanical mass-compliance-damping systems. They are described by a pair of zeroes at the [s-plane](#) origin and a pair of complex poles with a location defined by  $F_s$  and  $Q_t$ . The circuit above allows to place a pair of complex zeroes ( $F_z, Q_z$ ) on top of the pole pair to exactly compensate their effect. A new pair of poles ( $F_p, Q_p$ ) can then be placed at a lower or a higher frequency to obtain a different, more desirable frequency response.

This allows to extend the response of a [closed box woofer](#) to lower frequencies, in the above circuit example from 55 Hz to 19 Hz, provided the driver has adequate volume [displacement](#) capability and power handling. The equalizer frequency response is shown below, correcting for a woofer with peaked response ( $Q_p = 1.21$ ) and early roll-off ( $F_p = 55 \text{ Hz}$ ), to obtain a response that is 6 dB down at 19 Hz and with  $Q = 0.5$ .

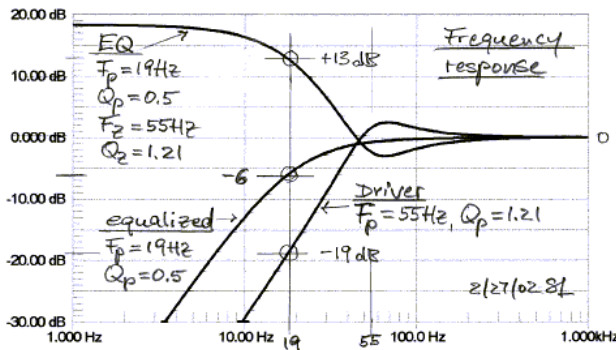

The associated phase and group delay responses are shown below.

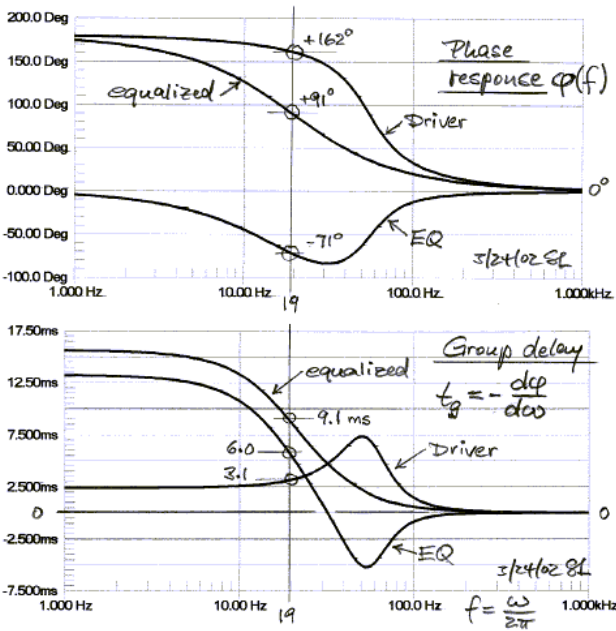

Not only is the frequency response extended, but the time response is also improved, as indicated by the reduced overshoot and

ringing of the lower cut-off highpass filter step response.

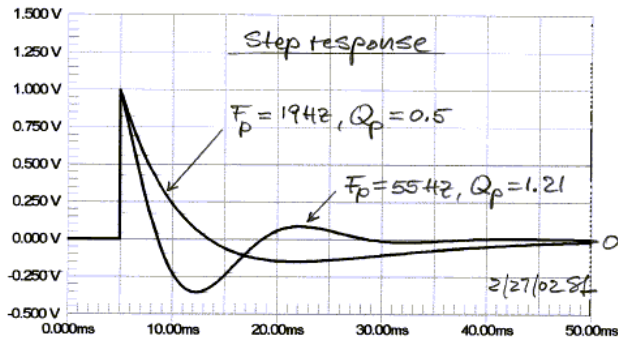

It can be seen from the s-plane description of the transfer functions that the complex poles of the driver in the box are canceled by a set of complex zeros in the equalizer. The specified real axis poles of the equalizer, together with the driver zeros at the s-plane origin, determine the overall loudspeaker response in frequency and time.

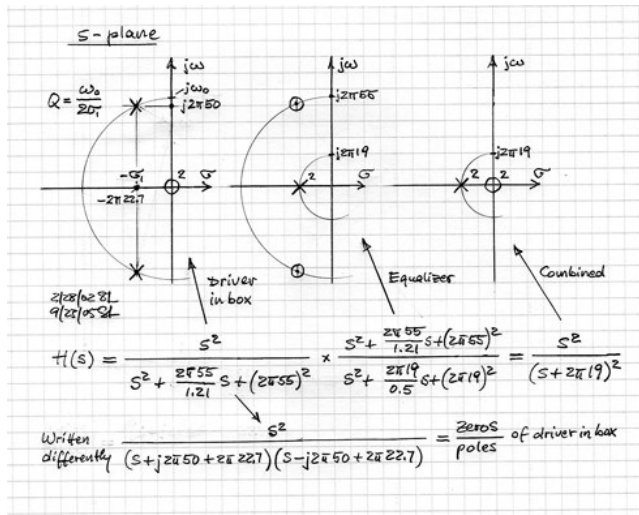

The equalizer action is difficult to visualize in the time domain, because the driver output waveform is the convolution of the input signal  $s(t)$  with the impulse response of the equalizer  $h_1(t)$ , which in turn must be convolved with the impulse response  $h_2(t)$  of the driver. Convolution is a process whereby the current value of the time response is determined by the time weighted integral over past behavior. Below are the responses of driver, equalizer and driver-equalizer combination, if the input signal  $s(t)$  is an impulse.

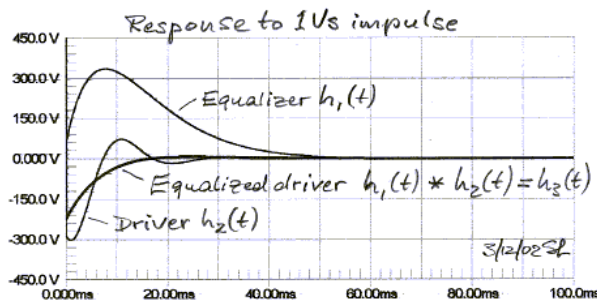

More illustrative are the responses to a 4-cycle, rectangular envelope 70 Hz toneburst  $s(t)$ . For example, the driver output is the convolution of the burst  $s(t)$  with the driver's impulse response  $h_2(t)$ . Note that the driver phase leads the input signal, as would be expected for a highpass response. Upon turn-off of the input burst at 57.14 ms the driver response rings towards zero, governed by  $F_p = 55$  Hz and  $Q_p = 1.21$ .



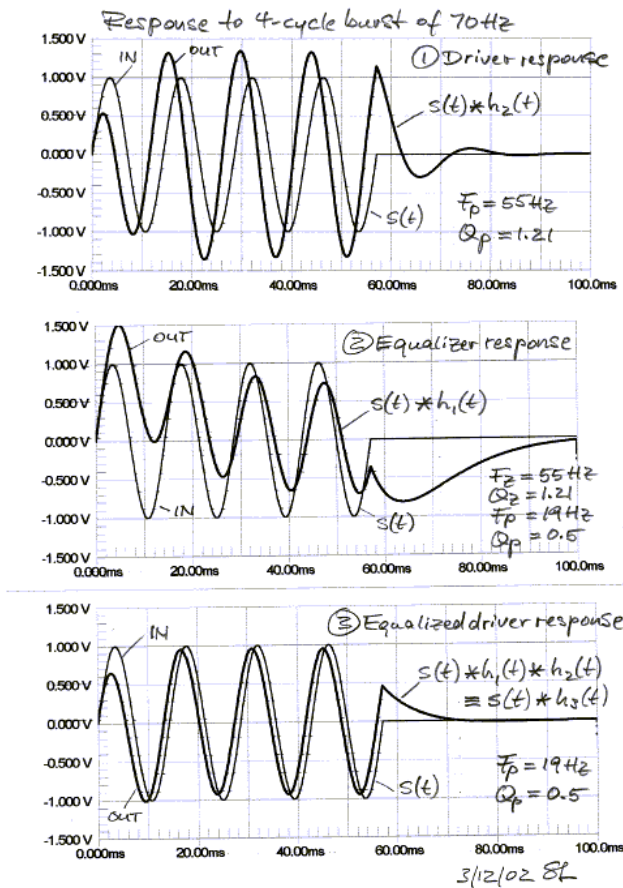

The equalizer output response lags its burst input. This signal will force upon the driver a response correction so that it is no longer dominated by  $F_p = 55 \text{ Hz}$  and  $Q_p = 1.21$ . The equalizer output signal is convolved with the impulse response  $h_2(t)$  of the driver to obtain the desired equalized driver output. Now, the decay of the driver output follows the 2nd order highpass filter response determined by  $Q_p = 0.5$  and  $F_p = 19 \text{ Hz}$  of the equalizer, after the excitation has stopped.

Of course, none of the driver mechanical parameters like mass, compliance and damping have been changed in the process of equalization, only the input signal to the driver has been modified.

The above circuit can also be used to correct the low frequency roll-off of a tweeter so that the equalized tweeter becomes a filter section in an exact LR4 acoustic highpass. ([f0Q0fpQp.gif](#), [pz-eql.xls](#), [f0Q0.gif](#), [FAQ15](#), [sb80-3wy.htm](#), [sb186-48.gif](#), [sb186-50.gif](#)) [Top](#)

## 10 - Variable gain & fixed attenuation

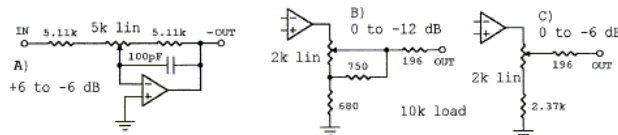

A major advantage of line-level active crossovers is the efficiency with which drivers of different sensitivity can be combined in a speaker system. The three circuits use linear taper potentiometers but obtain a gain variation that is approximately linear in dB. Circuits B and C assume a 10k ohm load such as the input impedance of the power amplifier. Circuit A is optimal between filter stages because of its low output impedance. The placement of the variable gain stage in the filter chain must be carefully considered, because it affects noise performance and signal handling. ([gain-adj.gif](#), [attnrout.gif](#), [38xo\\_eq1.gif](#)) [Top](#)

Occasionally a fixed attenuation of A dB or a is needed for the input voltage  $V_2$  of a circuit stage with input impedance  $R_3$  when driven from an operational amplifier with output voltage  $V_1$ . In the example below a 3 dB ( $a=1.41$ ) attenuation is desired. The load  $R_{in}$  that is seen by the opamp should be about 2000 ohm. The following amplifier stage has an input impedance of 10k ohm.

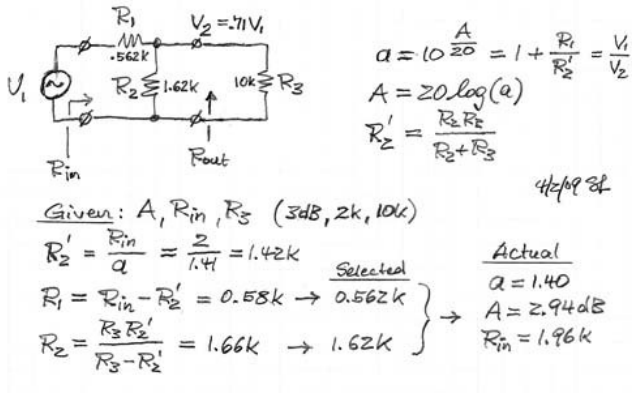

For designing an attenuator with specified output impedance  $R_{out}$  see: [attnrout.gif](#)

### 11 - Line driver

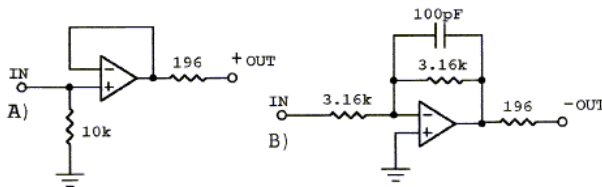

The output stage of the filter must be capable of driving cables, which typically have a capacitance in the order of 150 pF per meter length, without going into oscillation. A 196 ohm resistor maintains a resistive load component and tying output to negative input for out-of-band frequencies (>100 kHz) reduces loop gain. All of the above circuits can drive cables if operational amplifiers such as the [OPA2134](#) or OPA2604 are used. In most cases it is not necessary to have a separate line driver.

Performance of active circuits should always be checked for inter-stage clipping, and for oscillation with a wideband (>10 MHz) oscilloscope. [Top](#)

### 12 - Power supply

I recommend to leave the effort of building a regulated power supply to one of the many vendors that offer wallplug and tabletop models. An output specification of +/-12 V to +/-15 V DC at >250 mA and with <1% ripple and noise will suffice. Often such supplies can be found at electronic surplus stores. [Top](#)

### 13 - Printed circuit boards WM1 and MT1

To simplify the construction of active line-level equalizers and crossovers I offer three printed circuit boards, [ORION/ASP](#), WM1 and MT1. The circuit traces are laid out to allow for a variety of filter designs. It is up to the user to determine the actual circuit configuration and component values. Then the necessary components and jumpers are loaded at the appropriate locations on the board to obtain the desired filter response. I will provide specific information for assembling the PHOENIX crossover/equalizer on the ORION/ASP pcb and a Linkwitz Transform on the WM1 pcb.

**WM1** is designed to implement the functionality of circuits 1, 5, 6, 7, 8, 9 or 10 and various combinations of these. The circuit board provides two of the topologies below for two channels of equalization or for a more elaborate single channel response correction.

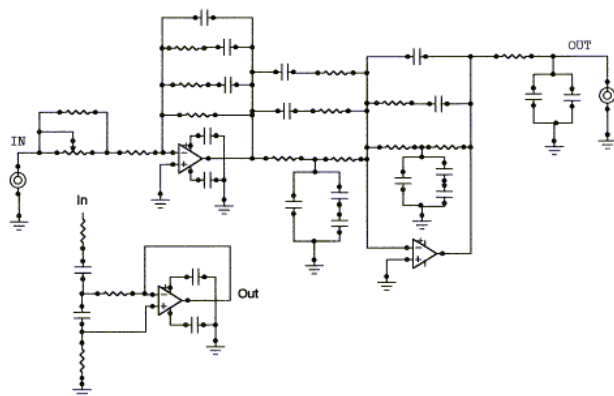

The WM1 board can be used for:

- Equalization of an existing speaker with passive crossovers, baffle step correction and extension of the low frequency response.
- Pole-zero equalization of a closed box woofer and a LR2 crossover lowpass filter. Variable gain.
- Pole-zero equalization of a midrange and a LR2 crossover highpass filter.
- Dipole woofer equalization with notch and variable gain. LR2 crossover lowpass.
- Dipole woofer equalization for low Qts drivers.
- Low frequency, individual channel and overall response equalization of multi-way speakers, so long as elements of this topology allow you to generate the response you need.
- Equalization of [add-on woofer](#), [FAQ10](#), [FAQ15](#)

**MT1** is designed to implement the functionality of circuits 1, 2, 3, 4, 5, 10 or 11 and various combinations of these. On the circuit board are two of the topologies below.

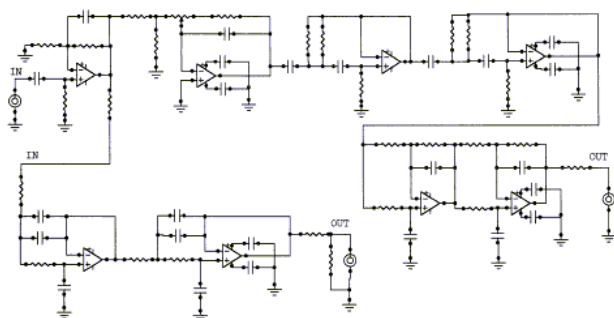

The MT1 board can be used to construct:

- A 2-way speaker with crossovers of order 1, 2, 3, or 4. The tweeter channel has variable gain and delay circuitry to align the tweeter's acoustic center with the woofer. The input buffer stage can provide 4p to 2p polar response (baffle step) correction.
- The tweeter and midrange channels of a 3-way system. The midrange highpass filter of the woofer to mid crossover would have to be provided by the WM1 board.
- The tweeter and upper midrange or upper midrange and lower midrange channels of a 4-way system.
- A great variety of active multi-channel line level filters in combination with the WM1 board.
- Crossover for [add-on woofer](#), [FAQ10](#), [FAQ15](#)

The circuit boards are practical tools to experiment with and to learn about active electronics. You will find that active loudspeaker systems give you the freedom to match drivers of greatly different sensitivities, are easier to design, and can give greater accuracy of sound reproduction, than is possible with passive, high-level crossovers and filters.

See the [Circuit Board](#) page for ordering information. [Top](#)

## 14 - Literature

Much useful information can be obtained from application notes of the various opamp manufacturers. If you need a refresher or an introduction to circuits, then read:

[1] Martin Hartley Jones, **A practical introduction to electronic circuits**, Cambridge University Press, 1995. It is a well illustrated, easy to read, yet technically solid text. It covers a broad range of devices - from tubes to ICs - and many basic circuit functions.

The following books cover a range of concepts and go into depth on specific, relevant topics to strengthen understanding of electronic circuits and electro-acoustic models.

- [2] Herman J. Blinchikoff & Anatol I. Zverev, **Filtering in the Time and Frequency Domains**, John Wiley, 1976. A broad and fundamental look at filters.
- [3] Arthur B. Williams & Fred J. Taylor, **Electronic Filter Design Handbook**, McGraw-Hill, 1995. Design and analysis formulas for all types of filters.
- [4] Jasper J. Goedbloed, **Electromagnetic Compatibility**, Prentice Hall, 1990. Fundamental concepts and practices for dealing with radio frequency interference.
- [5] Henry W. Ott, **Noise Reduction Techniques in Electronic Systems**, John Wiley, 1976. Practical steps to combat RFI.
- [6] Manfred Zollner & Eberhard Zwicker, **Elektroakustik**, Springer, 1998. The most comprehensive and solid engineering level presentation of electro-acoustic transducers and related subjects.  
In German, no comparable English language text available, to my knowledge.
- [7] Walter G. Jung, editor, **Op Amp Applications**, [Analog Devices](#), 2002. Everything you ever wanted to know about using operational amplifiers, and not just at audio frequencies.

[Top](#)

---

## PHOENIX ...

| [Build-Your-Own](#) | [Main Panel](#) | [Dipole Woofer](#) | [Crossover/EQ](#) | [Supplies](#) |  
| [System Test](#) | [Design Models](#) | [Prototypes](#) | [Active Filters](#) | [Surround](#) | [FAQ](#) |

**What you hear is not the air pressure variation in itself  
but what has drawn your attention  
in the two streams of superimposed air pressure variations at your eardrums**

---

Last revised: 02/17/2011 - © 1999-2011 LINKWITZ LAB, All Rights Reserved