

- 8 FILTER-OUT
- 7 FILTER-SIGNAL1
- 6 FILTER-SIGNAL2
- 5 FILTER-SIGNAL3
- 4 FILTER-SIGNAL4
- 3 FILTER-CV1
- 2 FILTER-CV2
- 1 FILTER-CV3

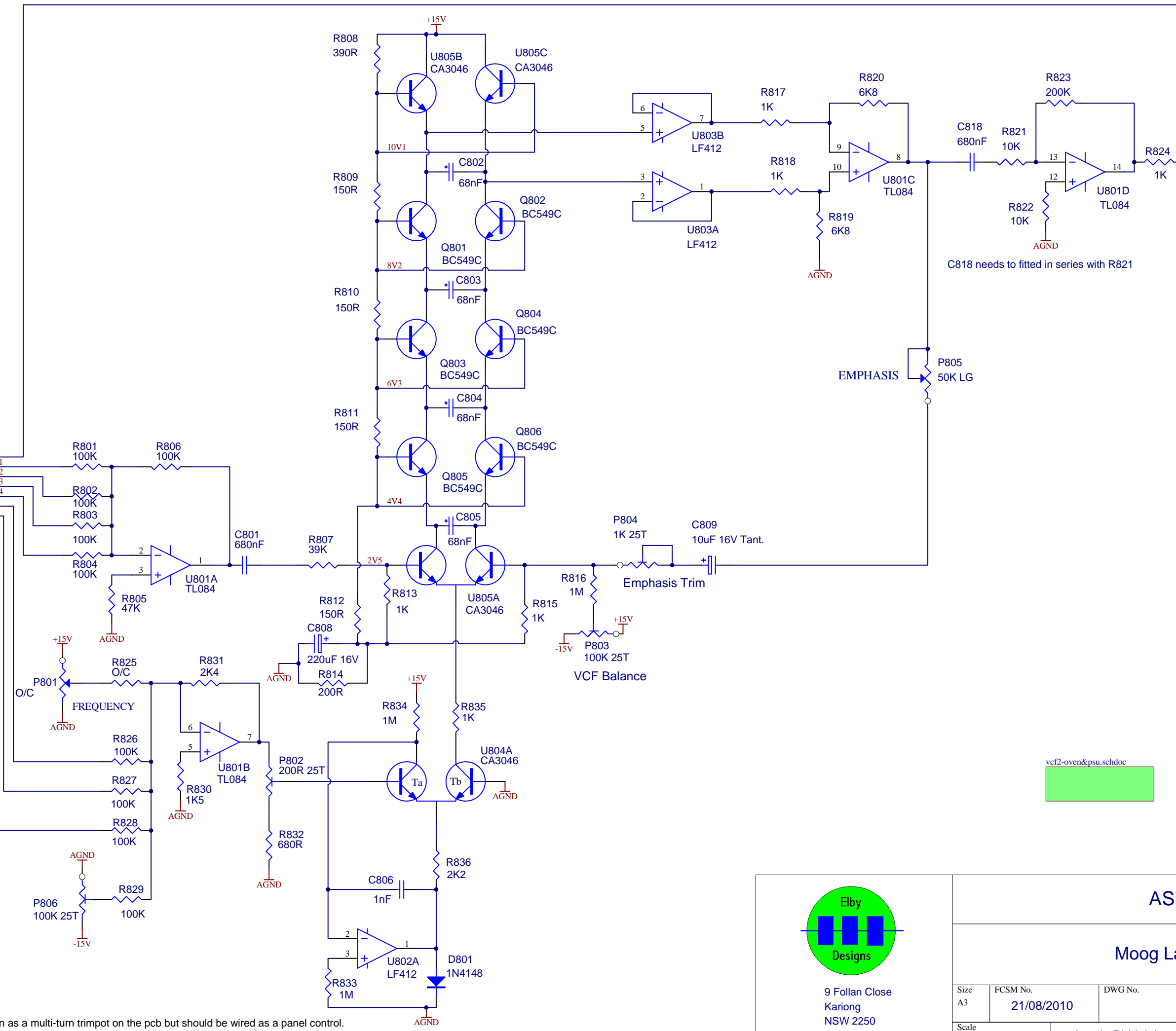

C818 needs to fitted in series with R821

Emphasis Trim
VCF Balance

vcf2-oven&psu.schdoc

P801 is incorrectly shown as a multi-turn trimpot on the pcb but should be wired as a panel control.

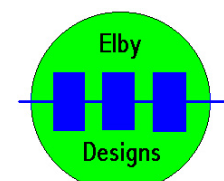

9 Follan Close
Karing
NSW 2250
Australia

ASM-2

Moog Ladder Filter

Size A3	FCSM No. 21/08/2010	DWG No. vcf2-filter.schdoc	Rev B
Scale	Sheet 14 of 24		Laurie Biddulph