

BERGFOTRON

LM13600 VCA 2

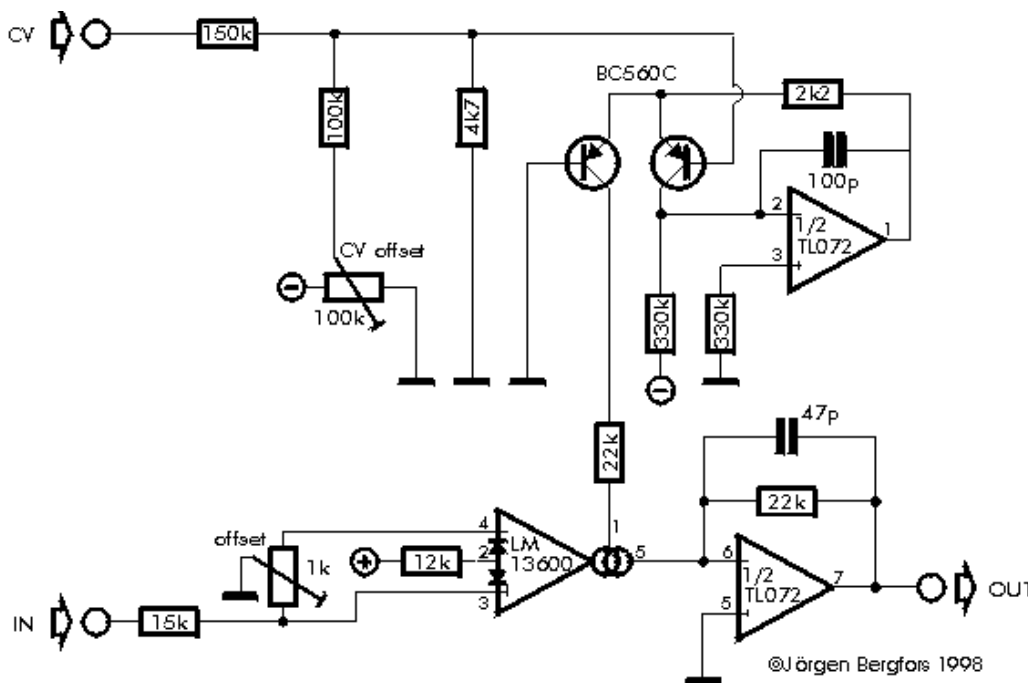

This circuit is identical to LM13600 VCA 1, with the exception of the output stage. Here, the load resistor is in the feedback loop of an inverting amplifier, instead of connected to ground. The effect this has on performance turned out to be negligible. Signal bleedthrough seems to be very slightly better, which makes this circuit to the overall winner.

Noise & signal attenuation

Red = signal bleedthrough at 0V CV. Blue = 10V CV, no signal. Green = 0V CV, no signal.

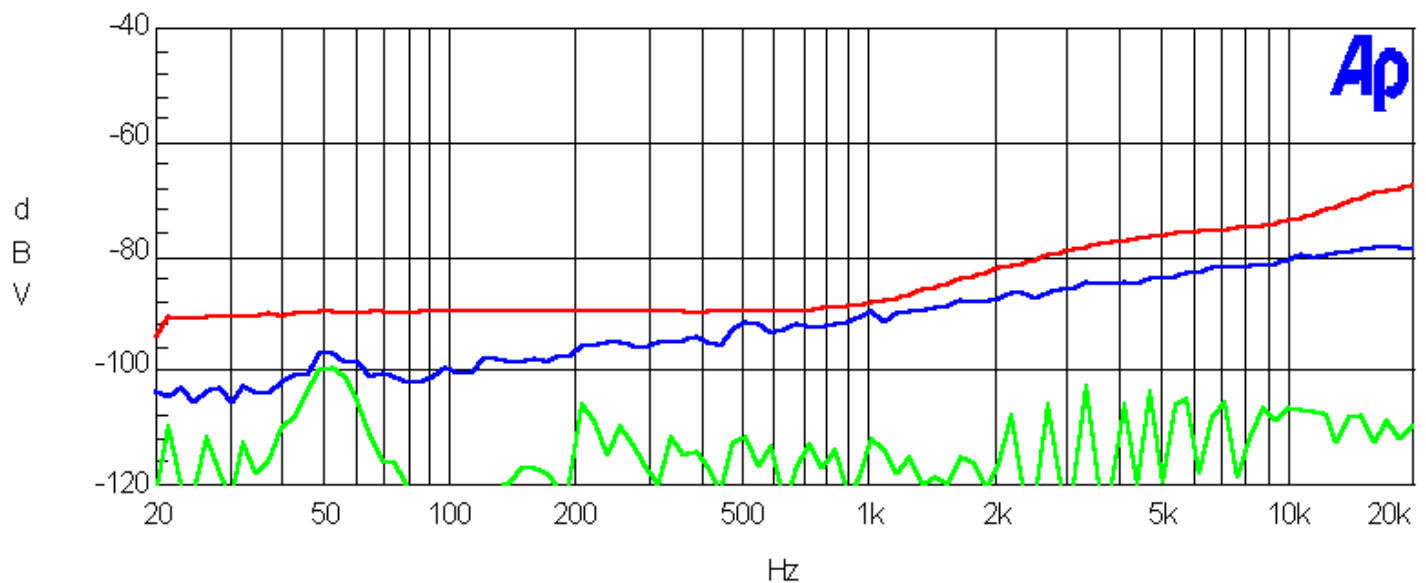

Distortion (THD+N) vs. input level

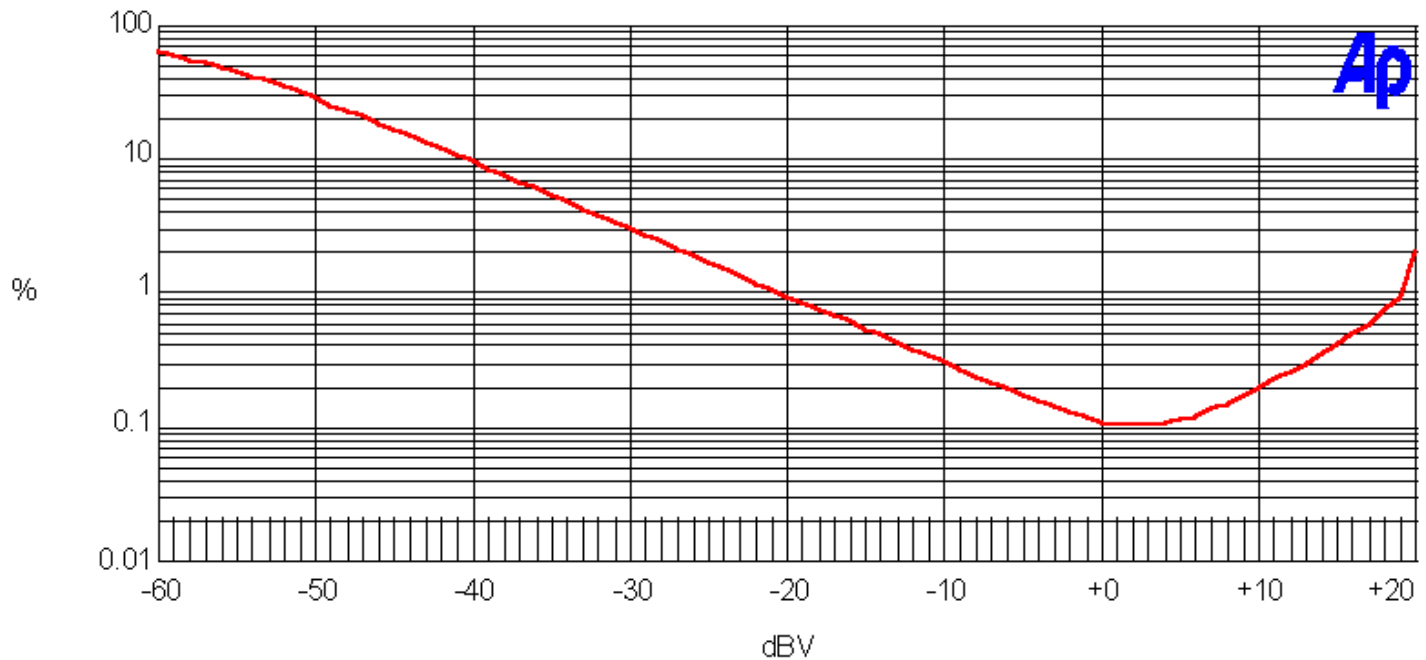

Frequency response

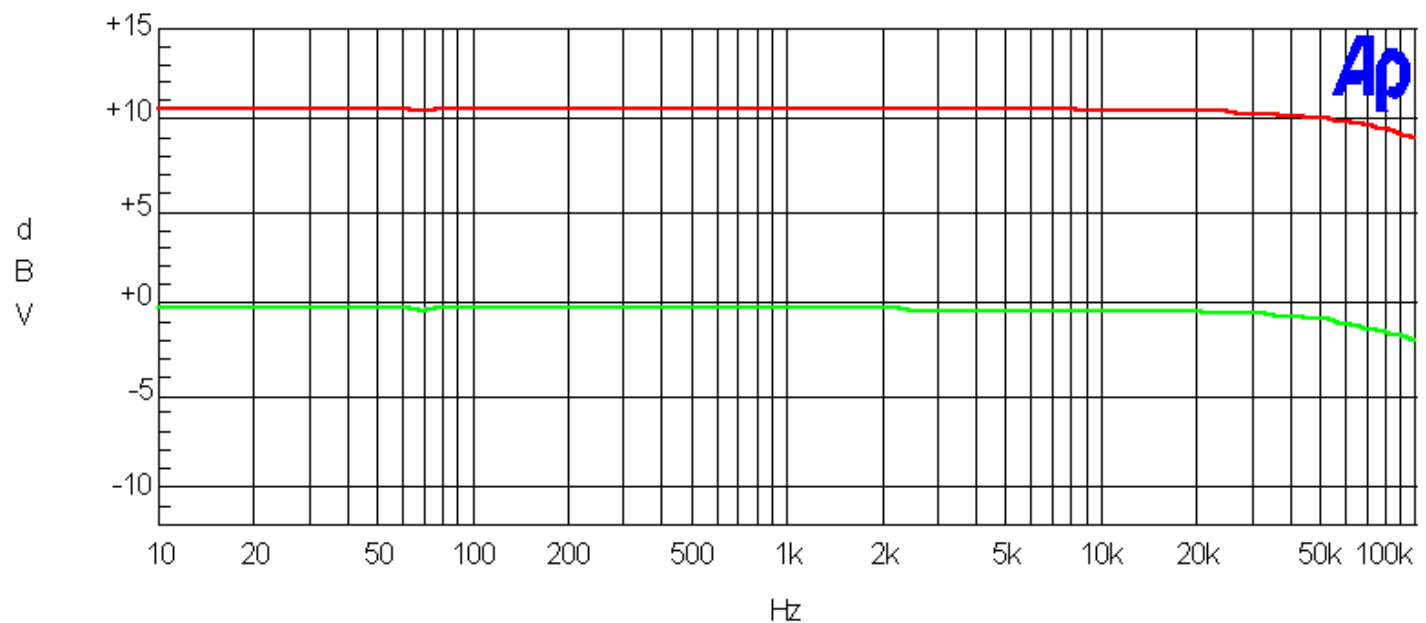

Test results

Dynamic range	10 V CV, no signal	82 dBr A
	0 V CV, no signal	109 dBr A
	0 V CV, 1kHz 10 V p-p in	98 dBr A
	0 V CV, 2 kHz 10 V p-p in	93 dBr A
	0 V CV, 10 kHz 10 V p-p in	85 dBr A
	Headroom (over 10V p-p)	8 dB
CV bleedthrough	after careful trimming	20 mV

Summary

A good, low cost VCA



- Low signal bleedthrough
- Low distortion
- High headroom



- Rather low input impedance