

An audio compressor serves to reduce (or compress) the dynamic range of the input signal. This keeps the level more constant, so that it will be clearly heard above background sounds, whether they be noise or accompanying musical sounds. An ideal compressor introduces little distortion and noise when it is inactive, and controls the audio level in a way that is pleasing to the ear.

Silonex optocouplers offer a cost competitive, high performance solution that fulfils these requirements. They offer the advantage over VCA based designs that the active element is essentially only in the circuit (and hence potentially causing distortion) when gain reduction is taking place. Distortion products tend to be low order harmonics that are less objectionable to the ear than high order crossover artifacts. The steady state amplitude performance of a compressor can be expressed in terms of three parameters.

The *Threshold* is the input amplitude above which compression starts to take place, see **Figure 1**.

When the signal rises above the Threshold point, the amount of compression that occurs is determined by the *Ratio* (see **Figure 2**), which is expressed as the quantity:

$$\frac{\text{Change of input signal level}}{\text{Change of output signal level}}$$

Since the action of the compressor is to make loud sounds quieter, it is normal to have some gain after it to restore the apparent loudness, this is termed *Makeup Gain*, see **Figure 3**.

The dynamic performance is usually described in terms of the "Attack" time. This is the time between the signal going above Threshold and the gain reduction reaching its maximum level (or a reasonable proportion of it), and the "Release" time, which is how long it takes for the gain reduction to go away.

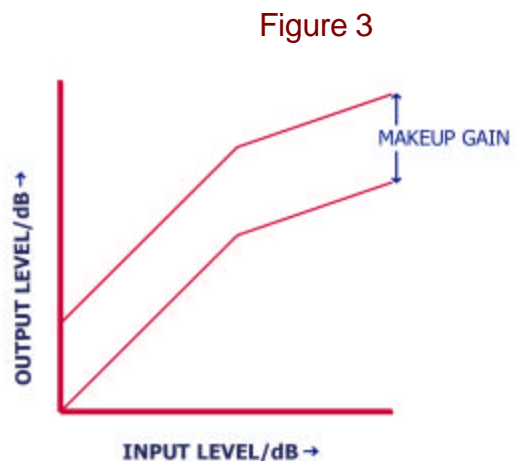
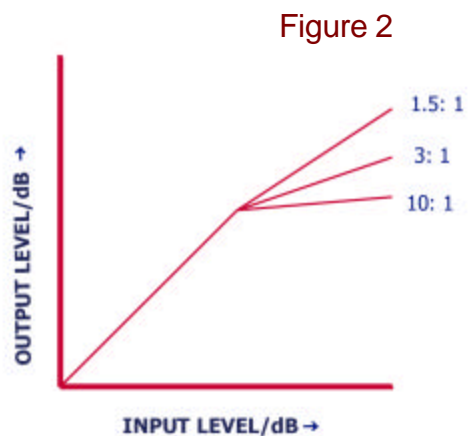
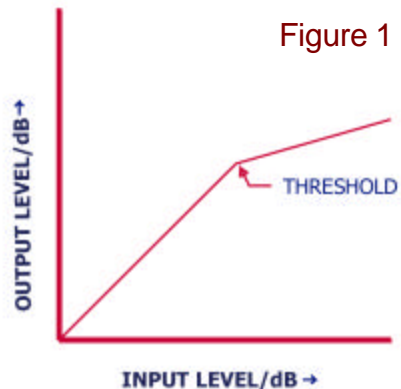

Compressor Applications for Resistive Optocouplers

Figure 4 shows the circuit for a simple compressor with fixed threshold, the amplitude response of which is shown in **Figure 5**.

OP1 in conjunction with R2 form a shunt attenuator which acts as the gain control element. The output is buffered by IC1 to prevent loading effects. The output of IC1 is half wave rectified by D1 and smoothed by R3 and C2, and then fed to the base of high gain transistor Q1. As soon as the circuit output level starts to exceed the Threshold set by the turn on voltages of D1 and Q1, Q1 will start to conduct, turning on OP1 which will reduce the output level.

Figure 4

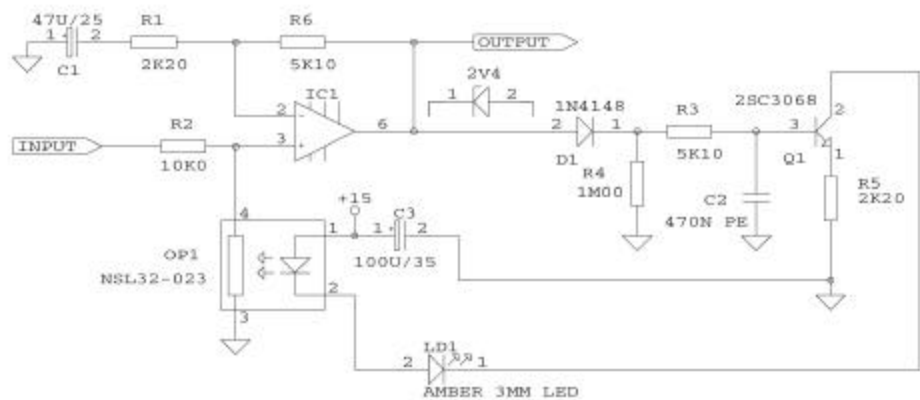

With the values shown this gain reduction starts at a Threshold of -10 dBu, this can be altered by adjusting R1 (smaller value = lower threshold) which conveniently adds an appropriate amount of makeup gain around IC1 at the same time. For Thresholds greater than 0 dB, a low voltage zener diode can be added in series with D1 as shown. The ratio is set by the coupler characteristics and R5, and with the value shown is approximately 3:1. The current flowing through the LED of OP1 also illuminates LD1, to indicate that gain reduction is taking place. R3 and C2 determine the Attack time, and $(R3+R4)$ and C2 the release, and need to be set for the particular application.

Figure 5

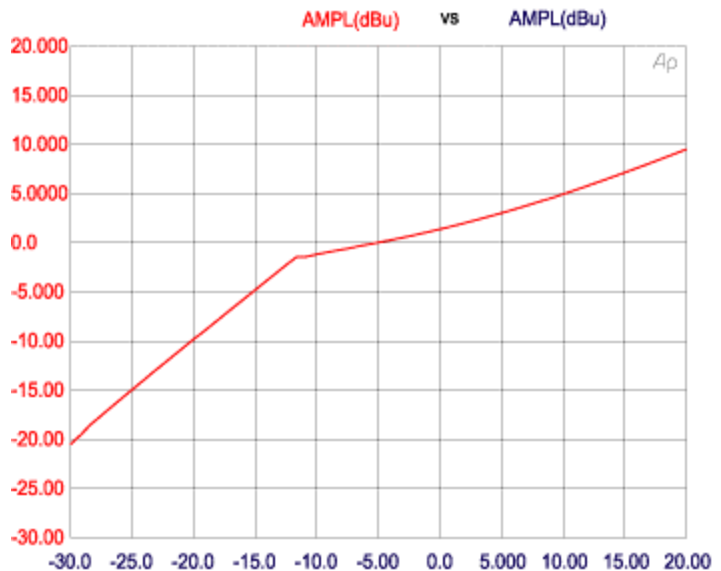

The circuit will run off split supplies of ± 6 to ± 15 V, allowing maximum input signal levels of up to $+20$ dBu RMS. IC1 can be any low noise/distortion operational amplifier, as long it has enough output drive capability to charge C2 without distorting. The input signal needs to come from a

Compressor Applications for Resistive Optocouplers

source with very low DC offset, since this would be modulated by the gain change, giving rise to audible "thumps". If in doubt, add a coupling capacitor to the input. A selected **NSL-32** coupler is used, providing remarkably good performance, with distortion at -12 dBu input typically less than 0.005% without gain reduction taking place. Distortion whilst compressing is a function of input frequency, the time constant of C2/R4 and the amount of gain reduction, and is typically better than 0.01% at 1 KHz/6 dB. The graded -023 version off the **NSL-32** is used for reasons of repeatability in the circuit. Unlike the limiter circuit, there is not a lot of loop gain to linearize the response. With a NE5532 for IC1, output noise is better than -99 dBu.

Figure 6 shows the schematic for a more comprehensive compressor circuit, that offers control over Threshold, Ratio, Attack, Release and Makeup gain.

Essentially the circuit works in a similar fashion to the limiter circuit, except that the threshold of the comparator is set at a low level (= -20 dBu) and the preceding Threshold control VR1 attenuates the rectified signal to alter the effective threshold. Local feedback from Q1 source to the comparator via VR2 and R2 allows adjustment of the ratio from 2:1 to approx 7:1, rather than the 100:1 ratio of the limiter that is achieved by only having low frequency feedback through the optocoupler action. The threshold range of -20 dBu to +10 dBu is shown in **Figure 7**, and the ratios at a Threshold of 0 dBu in **Figure 8**.

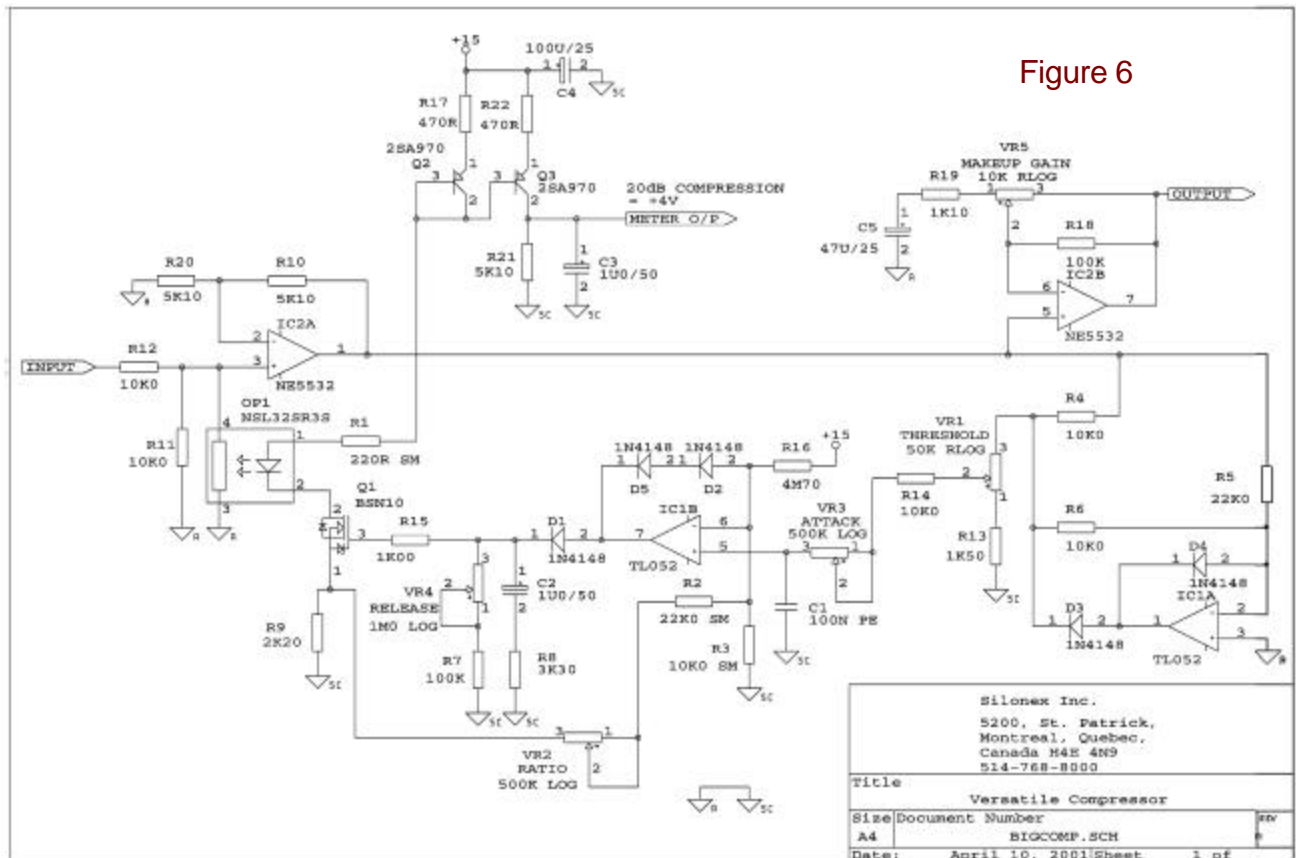

Compressor Applications for Resistive Optocouplers

Attack time is variable from ~1 msec to 20 msec via VR3, and the release time from 100msec to 1 sec via VR4. The variable gain stage around IC2B provides from 0...+20 dB Makeup Gain. Rather than just having an indicating LED in series with the optocoupler, a current mirror configured around Q2,3 and R17,22 generates a ground referenced voltage proportional to the current flowing through the coupler LED. This can be used to drive a meter (either an LED bar graph, or if you want a "retro" look, a moving coil meter) to give more information about how much gain reduction is taking place. In this circuit the graded **NSL-32SR3S** coupler is used, with a 6 dB pre-attenuator to further reduce distortion. This results in typical THD+N figures of <0.003% at +6 dBu I/P and no compression, and 0.03% at +10 dB and 3 dB compression (depending on the Attack and Release times set). Output noise with 0 dB makeup gain is < -106 dBu.

Figure 7

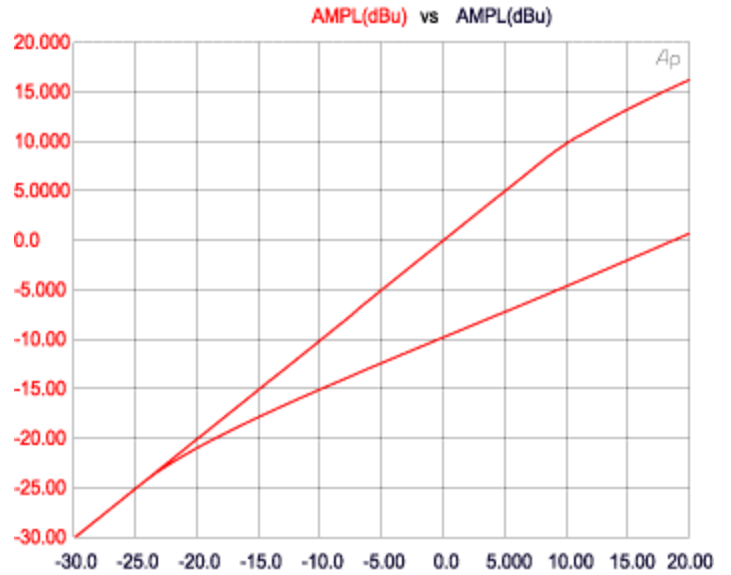

Figure 8

