

Single pushbutton long-period timer

With this circuit, only a single pushbutton switch is required to initiate or terminate a long-period timing cycle. IC1 is a 4027 JK flipflop and changes state on a rising clock edge. This occurs every time switch S1 is pressed, the output appearing at pin 15 (Q).

If Q is initially low, Q is high and binary counter IC2 is held reset with its Q14 output low. Closing S1 will cause Q to go high and Q to go low, thus releasing the reset on IC2 which is now clocked by Schmitt trigger oscillator IC3a. IC2 is subsequently reset (ie, Q low and Q high) either by a further switch operation or when Q14 of IC2 goes high.

In addition, the circuit may be reset during the timing cycle by applying an external reset signal to D2.

The maximum timing period (P) is nominally $P = 1.4(R1)(C1) \times 2^{n-1}$ seconds where Q_n is the 4020 output (for the circuit shown, $n = 14$). Possible applications include use as a verandah light or exhaust fan controller.

G. Cutter
Bentleigh, Vic.

\$20

Automatic volume control

Here is a simple circuit that will automatically adjust the volume of a car radio or cassette deck according to the ambient road of engine noise.

A microphone is placed under the bonnet of the car, either adjacent to the engine or one of the wheels, which ever causes the greatest noise problem. Its output is rectified by D1, filtered to provide a steady DC voltage, and fed to op amp IC1. The gain of IC1 is variable between one and 30 by means of a 100kΩ trimpot, while the non-inverting input is biased to half supply by two 100kΩ resistors.

The output of IC1 drives transistor Q1 which varies the current through a green LED. The output of the LED is then coupled to an LDR which, in turn, varies the resistance between the active and wiper terminals of the volume control. Thus, when the engine noise rises, the

LED brightness increases, the value of the LDR decreases, and the volume increases.

In practice, the 100kΩ trimpot should be adjusted so that the LED just lights with the engine at idle. The LED and the LDR should then be mounted inside a light-proof tube. The 50kΩ trimpot in series with the LDR functions as a sensitivity control.

B. Paterson,
Glen Iris, Vic.

\$15

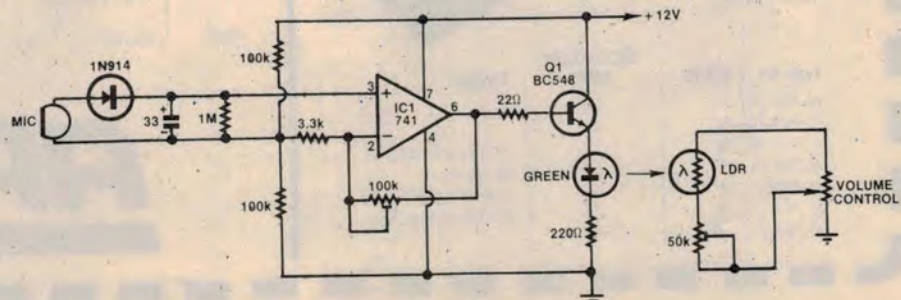

Modified supply for storage CRO Adapter

Some imported 2155-type transformers exhibit poor regulation characteristics and this can sometimes lead to problems in areas of low mains voltage. In the case of the Digital/Analog Storage CRO Adapter (EA, November 1980 and March 1981), it can lead to a very high ripple content on the $\pm 8.2V$ supply rails.

This problem can be overcome by altering the transformer tapings and adding a few extra components as shown. The 5V regulator now derives its supply from the 0, 6.3 and 12.6V tapings

instead of the 0, 7.5 and 15V tapings previously used. An extra 1000µF capacitor has also been added at the input, in parallel with the existing 2200µF capacitor, and this ensures that the regular input remains above its dropout voltage while reducing its dissipation.

The $\pm 8.2V$ supplies are derived from the 15V tapings. Diodes D3 and D5 provide half-wave rectification of the AC supply, while zener diodes D4 and D6 regulate the supply rails to $-8.2V$ and $+8.2V$ respectively. Note that an extra 100µF capacitor has been added across the 470µF capacitor used in the negative supply.

I. Stevenson,
Bracken Ridge, Qld.

\$15

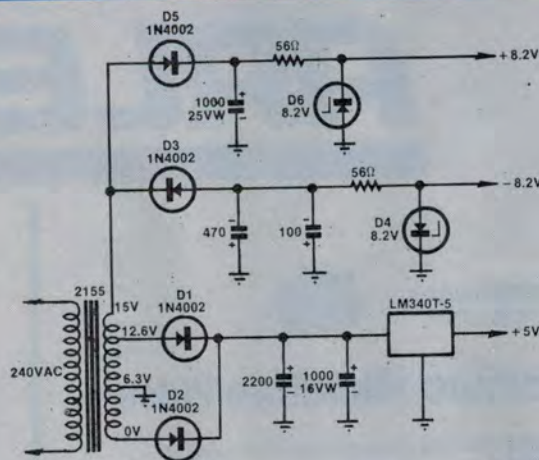

Wanted: your brain-waves

Come on now. You must have had some bright circuit and design ideas which are worth publishing. Why not send them in and make a little extra brass for more electronic components? We pay between \$5 and \$40 per item published, depending on the merit and the amount of work we have to do to publish it. Why not jot your idea down now and send it in?